

# YASKAWA

# GA800 Drive

## AC Drive for Industrial Applications Programming

Catalog Code: GA80Uxxxxxxx  
240 V: 1 to 150 HP  
480 V: 1 to 600 HP



---

**This Page Intentionally Blank**

# Table of Contents

|     |  |    |
|-----|--|----|
| i.  | Preface and General Precautions                            | 9  |
| i.1 | Document Use   | 10 |
| i.2 | Using the Product Safely                                   | 11 |
|     | Explanation of Signal Words                                | 11 |
|     | Section Safety   | 11 |
|     | Warning Label Content and Location                         | 13 |
| 1.  | Parameter List   | 15 |
| 1.1 | Section Safety   | 16 |
| 1.2 | How to Read the Parameter List                             | 17 |
|     | Icons and Terms that Identify Parameters and Control Modes | 17 |
| 1.3 | Parameter Groups   | 18 |
| 1.4 | A: Initialization Parameters                               | 20 |
|     | A1: Initialization   | 20 |
|     | A2: User Parameters  | 21 |
| 1.5 | b: Application   | 22 |
|     | b1: Operation Mode Selection                               | 22 |
|     | b2: DC Injection Braking and Short Circuit Braking         | 23 |
|     | b3: Speed Search   | 24 |
|     | b4: Timer Function   | 26 |
|     | b5: PID Control  | 27 |
|     | b6: Dwell Function   | 30 |
|     | b7: Droop Control  | 31 |
|     | b8: Energy Saving  | 31 |
|     | b9: Zero Servo   | 32 |
| 1.6 | C: Tuning  | 33 |
|     | C1: Accel & Decel Time                                     | 33 |
|     | C2: S-Curve Characteristics                                | 33 |
|     | C3: Slip Compensation                                      | 34 |
|     | C4: Torque Compensation                                    | 35 |
|     | C5: Auto Speed Regulator (ASR)                             | 36 |
|     | C6: Duty & Carrier Frequency                               | 38 |
| 1.7 | d: Reference Settings                                      | 39 |
|     | d1: Frequency Reference                                    | 39 |
|     | d2: Reference Limits                                       | 40 |
|     | d3: Jump Frequency   | 41 |
|     | d4: Frequency Ref Up/Down & Hold                           | 41 |
|     | d5: Torque Control   | 42 |
|     | d6: Field Weakening /Forcing                               | 42 |
|     | d7: Offset Frequency                                       | 43 |

|      |  |     |
|------|--|-----|
| 1.8  | E: Motor Parameters  | 44  |
|      | E1: V/f Pattern for Motor 1  | 44  |
|      | E2: Motor Parameters   | 45  |
|      | E3: V/f Pattern for Motor 2  | 46  |
|      | E4: Motor 2 Parameters   | 46  |
|      | E5: PM Motor Settings  | 47  |
|      | E9: Motor Setting  | 48  |
| 1.9  | F: Options   | 49  |
|      | F1: Encoder Option Setup   | 49  |
|      | F2: Analog Input Option  | 51  |
|      | F3: Digital Input Option   | 51  |
|      | F4: Analog Output Option   | 53  |
|      | F5: Digital Output Option  | 53  |
|      | F6: Communication Options  | 54  |
|      | F7: Ethernet Options   | 58  |
| 1.10 | H: Terminal Functions  | 61  |
|      | H1: Digital Inputs   | 61  |
|      | H2: Digital Outputs  | 66  |
|      | H3: Analog Inputs  | 73  |
|      | H4: Analog Outputs   | 76  |
|      | H5: Modbus Communication   | 77  |
|      | H6: Pulse Train Input/Output   | 78  |
|      | H7: Virtual MFIO selection   | 79  |
| 1.11 | L: Protection Functions  | 81  |
|      | L1: Motor Protection   | 81  |
|      | L2: Power Loss Ride Through  | 82  |
|      | L3: Stall Prevention   | 83  |
|      | L4: Speed Detection  | 85  |
|      | L5: Fault Restart  | 85  |
|      | L6: Torque Detection   | 87  |
|      | L7: Torque Limit   | 88  |
|      | L8: Drive Protection   | 88  |
|      | L9: Drive Protection 2   | 91  |
| 1.12 | n: Special Adjustment  | 92  |
|      | n1: Hunting Prevention   | 92  |
|      | n2: Auto Freq Regulator (AFR)  | 93  |
|      | n3: High Slip/Overexcite Braking   | 93  |
|      | n4: Adv Open Loop Vector Tune  | 94  |
|      | n5: Feed Forward Control   | 95  |
|      | n6: Online Tuning  | 95  |
|      | n7: EZ Drive   | 95  |
|      | n8: PM Motor Control Tuning  | 96  |
| 1.13 | o: Keypad-Related Settings   | 100 |
|      | o1: Keypad Display   | 100 |
|      | o2: Keypad Operation   | 102 |
|      | o3: Copy Keypad Function   | 103 |
|      | o4: Maintenance Monitors   | 104 |
|      | o5: Log Function   | 104 |
| 1.14 | q: DriveWorksEZ Parameters   | 106 |
|      | q1-01 to q8-40: Reserved for DriveWorksEZ                                  | 106 |
| 1.15 | r: DWEZ Connection 1-20  | 107 |
|      | r1-01 to r1-40: DriveWorksEZ Connection Parameters 1 to 20 (Upper / Lower) | 107 |
| 1.16 | T: Motor Tuning  | 108 |



|      |  |     |
|------|--|-----|
|      | T0: Tuning Mode Selection . . . . .  | 108 |
|      | T1: Induction Motor Auto-Tuning . . . . .  | 108 |
|      | T2: PM Motor Auto-Tuning . . . . .   | 109 |
|      | T3: ASR and Inertia Tuning . . . . .   | 110 |
|      | T4: EZ Tuning . . . . .  | 111 |
| 1.17 | U: Monitors . . . . .  | 112 |
|      | U1: Operation Status Monitors . . . . .  | 112 |
|      | U2: Fault Trace . . . . .  | 114 |
|      | U3: Fault History . . . . .  | 116 |
|      | U4: Maintenance Monitors . . . . .   | 117 |
|      | U5: PID Monitors . . . . .   | 121 |
|      | U6: Operation Status Monitors . . . . .  | 121 |
|      | U8: DriveWorksEZ Monitors . . . . .  | 124 |
| 1.18 | Parameters that Change from the Default Settings with A1-02 [Control Method Selection] . . . . .       | 125 |
| 1.19 | Parameters that Change from the Default Settings with E3-01 [Motor 2 Control Mode Selection] . . . . . | 130 |
| 1.20 | Parameters Changed by E1-03 [V/f Pattern Selection] . . . . .  | 131 |
| 1.21 | Defaults by Drive Model and Duty Rating ND/HD . . . . .  | 133 |
|      | 200 V class . . . . .  | 133 |
|      | 400 V class . . . . .  | 140 |
|      | 400 V class . . . . .  | 150 |
| 1.22 | Parameters Changed by PM Motor Code Selection . . . . .  | 161 |
|      | Yaskawa SMRA Series SPM Motors . . . . .   | 161 |
|      | Yaskawa SSR1 Series IPM Motors (Derated Torque) . . . . .  | 162 |
|      | Yaskawa SST4 Series IPM Motors (Constant Torque) . . . . .   | 172 |
| 2.   | Parameter Details . . . . .  | 183 |
| 2.1  | Section Safety . . . . .   | 184 |
| 2.2  | A: Initialization Parameters . . . . .   | 185 |
|      | A1: Initialization . . . . .   | 185 |
|      | A2: User Parameters . . . . .  | 203 |
| 2.3  | b: Application . . . . .   | 204 |
|      | b1: Operation Mode Selection . . . . .   | 204 |
|      | b2: DC Injection Braking and Short Circuit Braking . . . . .   | 217 |
|      | b3: Speed Search . . . . .   | 220 |
|      | b4: Timer Function . . . . .   | 230 |
|      | b5: PID control . . . . .  | 232 |
|      | b6: Dwell Function . . . . .   | 248 |
|      | b7: Droop Control . . . . .  | 249 |
|      | b8: Energy Saving . . . . .  | 250 |
|      | b9: Zero Servo . . . . .   | 255 |
| 2.4  | C: Tuning . . . . .  | 257 |
|      | C1: Acceleration and deceleration times . . . . .  | 257 |
|      | C2: S-Curve Characteristics . . . . .  | 262 |
|      | C3: Slip Compensation . . . . .  | 263 |
|      | C4: Torque Compensation . . . . .  | 268 |
|      | C5: Speed control (ASR: Automatic Speed Regulator) . . . . .   | 270 |
|      | C6: Duty & Carrier Frequency . . . . .   | 279 |
| 2.5  | d: Softstarter . . . . .   | 284 |
|      | d1: Frequency Reference . . . . .  | 284 |
|      | d2: Reference Limits . . . . .   | 290 |

|      |  |     |
|------|--|-----|
|      | d3: Jump Frequency                                     | 291 |
|      | d4: Frequency Ref Up/Down & Hold                       | 292 |
|      | d5: Torque Control                                     | 297 |
|      | d6: Field Weakening /Forcing                           | 302 |
|      | d7: Offset Frequency                                   | 303 |
| 2.6  | E: Motor Parameters                                    | 305 |
|      | E1: V/f Pattern for Motor 1                            | 305 |
|      | E2: Motor Parameters                                   | 313 |
|      | E3: V/f Pattern for Motor 2                            | 316 |
|      | E4: Motor 2 Parameters                                 | 318 |
|      | E5: PM Motor Settings                                  | 320 |
|      | E9: Motor Setting                                      | 323 |
| 2.7  | F: Options   | 326 |
|      | F1: PG Option Setup (Encoder)                          | 326 |
|      | F2: Analog Input Option                                | 333 |
|      | F3: Digital Input Option                               | 335 |
|      | F4: Analog Monitor Option                              | 339 |
|      | F5: Digital Output Option                              | 342 |
|      | F6, F7: Ethernet Options                               | 345 |
| 2.8  | H: Terminal Functions                                  | 367 |
|      | H1: Digital Inputs                                     | 367 |
|      | Multi-Function Digital Input Setting Values            | 371 |
|      | H2: Digital Outputs                                    | 390 |
|      | H2 MFDO Parameters                                     | 393 |
|      | MFDO Setting Value                                     | 400 |
|      | H3: Analog Inputs                                      | 415 |
|      | H3: MFAI Parameters                                    | 417 |
|      | Multi-Function Analog Input Terminal Settings          | 422 |
|      | H4: Analog Outputs                                     | 428 |
|      | H5: Memobus/Modbus Communication                       | 431 |
|      | H6: Pulse Train Input/Output                           | 435 |
|      | H7: Virtual MFIO selection                             | 439 |
| 2.9  | L: Protection Functions                                | 443 |
|      | L1: Motor Protection                                   | 443 |
|      | L2: Power Loss Ride Through                            | 449 |
|      | L3: Stall Prevention                                   | 460 |
|      | L4: Speed Detection                                    | 470 |
|      | L5: Auto Restart                                       | 471 |
|      | L6: Torque Detection                                   | 474 |
|      | L7: Torque Limit                                       | 480 |
|      | L8: Drive Protection                                   | 483 |
|      | L9: Drive Protection 2                                 | 491 |
| 2.10 | n: Special Adjustment                                  | 492 |
|      | n1: Hunting Prevention                                 | 492 |
|      | n2: Auto Freq Regulator (AFR)                          | 494 |
|      | n3: High Slip Braking (HSB) and Overexcitation Braking | 495 |
|      | n4: Adv Open Loop Vector Tune                          | 499 |
|      | n5: Feed Forward Control                               | 502 |
|      | n6: Online Tuning                                      | 505 |
|      | n7: EZ Drive   | 506 |
|      | n8: PM Motor Control Tuning                            | 507 |
| 2.11 | o: Keypad-Related Settings                             | 518 |
|      | o1: Keypad Display Selection                           | 518 |
|      | o2: Keypad Operation                                   | 526 |

|      |   |     |
|------|---|-----|
|      | o3: Copy Function . . . . .                                     | 530 |
|      | o4: Maintenance Mon Settings . . . . .                          | 532 |
|      | o5: Log Function . . . . .                                      | 535 |
| 2.12 | T: Auto-Tuning . . . . .  | 540 |
|      | T0: Tuning Mode Selection . . . . .                             | 540 |
|      | T1: Induction Motor Auto-Tuning . . . . .                       | 540 |
|      | T2: PM Motor Auto-Tuning . . . . .                              | 543 |
|      | T3: ASR and Inertia Tuning . . . . .                            | 546 |
|      | T4: EZ Tuning . . . . .   | 547 |
| 3.   | Keypad Use and Test Run . . . . .                               | 549 |
| 3.1  | Section Safety . . . . .  | 550 |
| 3.2  | Keypad: Names and Functions . . . . .                           | 551 |
|      | LCD Display . . . . .   | 553 |
|      | Indicator LEDs and Drive Status . . . . .                       | 554 |
|      | Keypad Mode and Menu Displays . . . . .                         | 555 |
| 3.3  | LED Status Ring . . . . .                                       | 557 |
| 3.4  | Keypad Operation . . . . .                                      | 559 |
|      | Use the HOME Screen . . . . .                                   | 559 |
|      | Displaying the Monitor . . . . .                                | 560 |
|      | Set Custom Monitors . . . . .                                   | 561 |
|      | Show Custom Monitors . . . . .                                  | 562 |
|      | Set the Monitors to Show as a Bar Graph . . . . .               | 563 |
|      | Show Monitors as Bar Graphs . . . . .                           | 564 |
|      | Set the Monitors to Show as Analog Gauges . . . . .             | 565 |
|      | Display Monitors as an Analog Gauge . . . . .                   | 566 |
|      | Set Monitoring Items to be Shown as a Trend Plot . . . . .      | 566 |
|      | Show Monitor Items as a Trend Plot . . . . .                    | 570 |
|      | Change Parameter Settings . . . . .                             | 571 |
|      | Examine User Custom Parameters . . . . .                        | 572 |
|      | Save a Backup of Parameters . . . . .                           | 574 |
|      | Write Backed-up Parameters to the Drive . . . . .               | 575 |
|      | Verify Keypad Parameters and Drive Parameters . . . . .         | 576 |
|      | Delete Parameters Backed Up to the Keypad . . . . .             | 577 |
|      | Check Modified Parameters . . . . .                             | 578 |
|      | Restore Modified Parameters to Defaults . . . . .               | 580 |
|      | Show Fault History . . . . .                                    | 581 |
|      | Auto-Tuning the Drive . . . . .                                 | 582 |
|      | Set the Keypad Language Display . . . . .                       | 584 |
|      | Set the Date and Time . . . . .                                 | 585 |
|      | Set Parameters Using the Setup Wizard . . . . .                 | 587 |
|      | Disable the Initial Setup Screen . . . . .                      | 589 |
|      | Start Data Logging . . . . .                                    | 590 |
|      | Configuring the Data Log Content . . . . .                      | 591 |
|      | Set Backlight to Automatically Turn OFF . . . . .               | 593 |
|      | Show Information about the Drive . . . . .                      | 594 |
|      | Write Automatically Backed-up Parameters to the Drive . . . . . | 595 |
| 3.5  | Auto-Tuning . . . . .   | 597 |
|      | Auto-Tuning for Induction Motors . . . . .                      | 597 |
|      | Auto-Tuning for Motor Parameters for PM Motor . . . . .         | 598 |
|      | Auto-Tuning in EZ Open Loop Vector Control Method . . . . .     | 600 |
|      | Control Tuning . . . . .  | 601 |
|      | Precautions before Auto-Tuning . . . . .                        | 603 |
| 3.6  | Test Run . . . . .  | 606 |

|     |  |     |
|-----|--|-----|
|     | No-Load Test Run . . . . .   | 606 |
|     | Do a No-Load Test Run . . . . .  | 606 |
|     | Actual-Load Test Run . . . . .   | 606 |
|     | Do an Actual-Load Test Run . . . . .                                       | 607 |
| 3.7 | Fine Tuning during Test Runs (Adjust the Control Function) . . . . .       | 608 |
|     | V/f Control and Closed Loop V/f Control . . . . .                          | 608 |
|     | Open Loop Vector Control Method . . . . .                                  | 609 |
|     | Closed Loop Vector Control Method . . . . .                                | 610 |
|     | Advanced Open Loop Vector Control Method . . . . .                         | 611 |
|     | Fine-Tuning Open Loop Vector Control for PM Motors . . . . .               | 612 |
|     | Advanced Open Loop Vector Control Method for PM . . . . .                  | 613 |
|     | Closed Loop Vector Control Method for PM . . . . .                         | 613 |
|     | EZ Open Loop Vector Control Method . . . . .                               | 614 |
| 3.8 | Test Run Checklist . . . . .   | 615 |
| 4.  | Mechanical & Electrical Installation . . . . .                             | 617 |
| 4.1 | Section Safety . . . . .   | 618 |
| 4.2 | Removing/Reattaching Covers . . . . .                                      | 622 |
|     | Removing/Reattaching the Cover Using Procedure A . . . . .                 | 622 |
|     | Removing/Reattaching the Cover Using Procedure B . . . . .                 | 623 |
| 4.3 | Electrical Installation . . . . .  | 627 |
|     | Standard Connection Diagram . . . . .                                      | 627 |
| 4.4 | Main Circuit Wiring . . . . .  | 631 |
|     | Motor and Main Circuit Connections . . . . .                               | 631 |
|     | Main Circuit Terminal Functions . . . . .                                  | 631 |
| 4.5 | Control Circuit Wiring . . . . .   | 633 |
|     | Control Circuit Connection Diagram . . . . .                               | 633 |
|     | Control Circuit Terminal Block Functions . . . . .                         | 634 |
|     | Control Circuit Terminal Configuration . . . . .                           | 636 |
|     | Wiring the Control Circuit Terminal . . . . .                              | 638 |
|     | Switches and Jumpers on the Terminal Board . . . . .                       | 641 |
| 4.6 | Control I/O Connections . . . . .  | 642 |
|     | Pulse Train Output . . . . .   | 642 |
|     | Set Sinking Mode/Sourcing Mode . . . . .                                   | 643 |
|     | Set Input Signals for MFAI Terminals A1 to A3 . . . . .                    | 643 |
|     | Set MFAI Terminal A3 to PTC Input . . . . .                                | 644 |
|     | Set Output Signals for MFAO Terminals FM, AM . . . . .                     | 645 |
|     | Switch ON Termination Resistor for MEMOBUS/Modbus Communications . . . . . | 645 |
| 4.7 | Connect the Drive to a PC . . . . .  | 646 |
|     | Index . . . . .  | 647 |
|     | Revision History . . . . .   | 653 |

# Preface and General Precautions

---

This chapter gives information about important safety precautions for the use of this product. Failure to obey these precautions can cause serious injury or death, or damage to the product or related devices and systems. Yaskawa must not be held responsible for any injury or equipment damage as a result of the failure to observe these precautions and instructions.

|            |                                       |           |
|------------|---------------------------------------|-----------|
| <b>i.1</b> | <b>Document Use .....</b>             | <b>10</b> |
| <b>i.2</b> | <b>Using the Product Safely .....</b> | <b>11</b> |

## **i.1 Document Use**

This document is for user operation and programming of installed Yaskawa GA800 drives. It is intended for use by those familiar with programming and modifying variable frequency drives. This document does not contain information to support of Yaskawa GA800 drives. For more information about the GA800 drive, refer to the GA800 Technical Manual (SIEPC\*\*\*\*\*).

### **Yaskawa Technical Support**

- repair@yaskawa.com
- Toll Free - 1.800.927.5292
- Direct - 1.847.887.7457
- Option 2 for Technical Support, then option 1 for Drive Support

### **Before You Call...**

Please have the following information available:

- Model and spec number of the unit
- Serial Number
- Failure Information (fault and alarm codes, descriptions)
- Application which the product is used on
- Length of time in service

## i.2 Using the Product Safely

### ◆ Explanation of Signal Words

#### **⚠ WARNING**

**Read and understand this manual before you install, operate, or do maintenance on the drive. Install the drive as specified by this manual and local codes.**

The symbols in this section identify safety messages in this manual. If you do not obey these safety messages, the hazards can cause serious injury, death, or damage to the products and related equipment and systems.

These identifier words categorize and emphasize important safety precautions in these instructions.

#### **⚠ DANGER**

**This signal word identifies a hazard that will cause serious injury or death if you do not prevent it.**

#### **⚠ WARNING**

**This signal word identifies a hazard that can cause death or serious injuries if you do not prevent it.**

#### **⚠ CAUTION**

**This signal word identifies a hazard that can cause moderate injuries if you do not prevent it.**

#### **NOTICE**

**This signal word identifies a property damage message that is not related to personal injury.**

### ◆ Section Safety

#### **General Precautions**

- Some figures in the instructions include options and drives without covers or safety shields to more clearly show the inside of the drive. Replace covers and shields before operation. Use options and drives only as specified by the instructions.
- The figures in this manual are examples only. All figures do not apply to all products included in this manual.
- Yaskawa can change the products, specifications, and content of the instructions without notice to make the product and/or the instructions better.
- If you damage or lose these instructions, contact a Yaskawa representative or the nearest Yaskawa sales office on the rear cover of the manual, and tell them the document number on the front cover to order new copies.

#### **⚠ DANGER**

**Do not ignore the safety messages in this manual.**

If you ignore the safety messages in this manual, it will cause serious injury or death. The manufacturer is not responsible for injuries or damage to equipment.

#### **Electrical Shock Hazard**

**Do not examine, connect, or disconnect wiring on an energized drive. Before servicing, disconnect all power to the equipment and wait for the time specified on the warning label at a minimum. The internal capacitor stays charged after the drive is de-energized. The charge indicator LED extinguishes when the DC bus voltage decreases below 50 Vdc. When all indicators are OFF, remove the covers before measuring for dangerous voltages to make sure that the drive is safe.**

If you do work on the drive when it is energized, it will cause serious injury or death from electrical shock. The drive has internal capacitors that stay charged after you de-energize the drive.

**⚠ WARNING**

**Crush Hazard**

**Test the system to make sure that the drive operates safely after you wire the drive and set parameters.**

If you do not test the system, it can cause damage to equipment or serious injury or death.

**Sudden Movement Hazard**

**Before you do a test run, make sure that the setting values for virtual input and output function parameters are correct. Virtual input and output functions can have different default settings and operation than wired input and output functions.**

Incorrect function settings can cause serious injury or death.

**Remove all personnel and objects from the area around the drive, motor, and machine and attach covers, couplings, shaft keys, and machine loads before you energize the drive.**

If personnel are too close or if there are missing parts, it can cause serious injury or death.

**Examine the I/O signals and internal sequence with the engineer who made the DriveWorksEZ program before you operate the drive.**

If you do not know how the drive will operate, it can cause serious injury or death. When you use DriveWorksEZ to make custom programming, the drive I/O terminal functions change from factory settings and the drive will not operate as written in this manual.

**Electrical Shock Hazard.**

**Do not modify the drive body or drive circuitry.**

Modifications to drive body and circuitry can cause serious injury or death, will cause damage to the drive, and will void the warranty. Yaskawa is not responsible for modifications of the product made by the user.

**Electrical Shock Hazard**

**Only let approved personnel install, wire, maintain, examine, replace parts, and repair the drive.**

If personnel are not approved, it can cause serious injury or death.

**Do not remove covers or touch circuit boards while the drive is energized.**

If you touch the internal components of an energized drive, it can cause serious injury or death.

**After the drive blows a fuse or trips a GFCI, do not immediately energize the drive or operate peripheral devices. Wait for the time specified on the warning label at a minimum and make sure that all indicators are OFF. Then check the wiring and peripheral device ratings to find the cause of the problem. If you do not know the cause of the problem, contact Yaskawa before you energize the drive or peripheral devices.**

If you do not fix the problem before you operate the drive or peripheral devices, it can cause serious injury or death.

**After the drive blows a fuse or trips an RCM/RCD, do not immediately energize the drive or operate peripheral devices. Wait for the time specified on the warning label at a minimum and make sure that all indicators are OFF. Then check the wiring and peripheral device ratings to find the cause of the problem. If you do not know the cause of the problem, contact Yaskawa before you energize the drive or peripheral devices.**

If you do not fix the problem before you operate the drive or peripheral devices, it can cause serious injury or death.

**After the drive blows a fuse or trips an ELCB, do not immediately energize the drive or operate peripheral devices. Wait for the time specified on the warning label at a minimum and make sure that all indicators are OFF. Then check the wiring and peripheral device ratings to find the cause of the problem. If you do not know the cause of the problem, contact Yaskawa before you energize the drive or peripheral devices.**

If you do not fix the problem before you operate the drive or peripheral devices, it can cause serious injury or death.

**Fire Hazard**

**Do not use the main circuit power supply (Overvoltage Category III) at incorrect voltages. Operate the drive in the specification range of the input voltage on the drive nameplate.**

Voltages that are higher than the permitted nameplate tolerance can cause damage to the drive.



**NOTICE****Fire Hazard**

**Install sufficient branch circuit short circuit protection as specified by applicable codes and this manual. The drive is suited for circuits that supply not more than 31,000 RMS symmetrical amperes, 240 Vac maximum (200 V Class), 480 Vac maximum (400 V Class).**

Failure to obey can cause death or serious injury.

**⚠ CAUTION****Crush Hazard**

**Tighten terminal cover screws and hold the case safely when you move the drive.**

If the drive or covers fall, it can cause moderate injury.

**NOTICE**

**Use an inverter-duty motor or vector-duty motor with reinforced insulation and windings applicable for use with an AC drive.**

If the motor does not have the correct insulation, it can cause a short circuit or ground fault from insulation deterioration.

**When you touch the drive and circuit boards, make sure that you observe correct electrostatic discharge (ESD) procedures.**

If you do not follow procedures, it can cause ESD damage to the drive circuitry.

**Do not do a withstand voltage test or use a Megger insulation tester on the drive.**

These tests can cause damage to the drive.

**Do not operate a drive or connected equipment that has damaged or missing parts.**







You can cause damage to the drive and connected equipment.

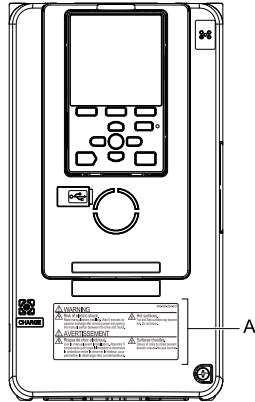
**Do not use steam or other disinfectants to fumigate wood for packaging the drive. Use alternative methods, for example heat treatment, before you package the components.**

Gas from wood packaging fumigated with halogen disinfectants, for example fluorine, chlorine, bromine, iodine or DOP gas (phthalic acid ester), can cause damage to the drive.

**◆ Warning Label Content and Location**

The drive warning label is in the location shown in Figure i.1. Use the drive as specified by this information.

|   |  |
|---|--|
|  <b>WARNING</b>  |  |
|  <b>Risk of electric shock.</b><br>Read manual before installing. Wait 5 minutes for capacitor discharge after removing power and opening the manual switch between the drive and motor.   |  <b>Hot surfaces.</b><br>Top and Side surfaces may become hot. Do not touch.                    |
|  <b>AVERTISSEMENT</b>  |  |
|  <b>Risque de choc électrique.</b><br>Lire le manuel avant l'installation. Attendre 5 minutes après avoir coupé l'alimentation et déconnecté la protection entre le driver et le moteur, pour permettre la décharge des condensateurs. |  <b>Surfaces chaudes.</b><br>Dessus et cotés du boîtier peuvent devenir chauds. Ne pas toucher. |



A - Warning label

Figure i.1 Warning Label Content and Location

## Parameter List

|      |  |     |
|------|--|-----|
| 1.1  | Section Safety .....   | 16  |
| 1.2  | How to Read the Parameter List .....   | 17  |
| 1.3  | Parameter Groups .....   | 18  |
| 1.4  | A: Initialization Parameters.....  | 20  |
| 1.5  | b: Application .....   | 22  |
| 1.6  | C: Tuning .....  | 33  |
| 1.7  | d: Reference Settings.....   | 39  |
| 1.8  | E: Motor Parameters.....   | 44  |
| 1.9  | F: Options.....  | 49  |
| 1.10 | H: Terminal Functions .....  | 61  |
| 1.11 | L: Protection Functions .....  | 81  |
| 1.12 | n: Special Adjustment.....   | 92  |
| 1.13 | o: Keypad-Related Settings .....   | 100 |
| 1.14 | q: DriveWorksEZ Parameters.....  | 106 |
| 1.15 | r: DWEZ Connection 1-20 .....  | 107 |
| 1.16 | T: Motor Tuning .....  | 108 |
| 1.17 | U: Monitors.....   | 112 |
| 1.18 | Parameters that Change from the Default Settings with A1-02 [Control Method Selection] .....       | 125 |
| 1.19 | Parameters that Change from the Default Settings with E3-01 [Motor 2 Control Mode Selection] ..... | 130 |
| 1.20 | Parameters Changed by E1-03 [V/f Pattern Selection] .....  | 131 |
| 1.21 | Defaults by Drive Model and Duty Rating ND/HD.....   | 133 |
| 1.22 | Parameters Changed by PM Motor Code Selection .....  | 161 |

## 1.1 Section Safety










 **DANGER**

**Do not ignore the safety messages in this manual.**

If you ignore the safety messages in this manual, it will cause serious injury or death. The manufacturer is not responsible for injuries or damage to equipment.

## 1.2 How to Read the Parameter List

### ◆ Icons and Terms that Identify Parameters and Control Modes

| Icon  | Description   |
|---|---|
|  | The parameter is available when operating the drive with V/f Control.                                 |
|  | The parameters is available when operating the drive with Closed Loop V/f Control.                    |
|  | The parameter is available when operating the drive with Open Loop Vector Control.                    |
|  | The parameter is available when operating the drive with Closed Loop Vector Control.                  |
|  | The parameter is available when operating the drive with Advanced Open Loop Vector Control.           |
|  | The parameter is available when operating the drive with Open Loop Vector Control for PM.             |
|  | The parameter is available when operating the drive with Advanced Open Loop Vector Control for PM.    |
|  | The parameter is available when operating the drive with Closed Loop Vector Control for PM.           |
|  | The parameter is available when operating the drive with EZ Open Loop Vector Control.                 |
| Hex.  | Hexadecimal numbers that represent MEMOBUS addresses to change parameters over network communication. |
| RUN   | The parameter can be changed settings during run.   |
| Expert  | The parameter that is available in Expert Mode only. *1   |

\*1 Set  $A1-01 = 3$  [*Access Level Selection = Expert Level*] to display and set Expert Mode parameters on the keypad.

**Note:**

Gray icons identify parameters that are not available in the specified control method.

## 1.3 Parameter Groups

### 1.3 Parameter Groups

Represents the type of product parameters.

| Parameters | Name   | Parameters | Name                         |
|------------|--|------------|------------------------------|
| A1         | Initialization                                 | H3         | Analog Inputs                |
| A2         | User Parameters                                | H4         | Analog Outputs               |
| b1         | Operation Mode Selection                       | H5         | Modbus Communication         |
| b2         | DC Injection Braking and Short Circuit Braking | H6         | Pulse Train Input/Output     |
| b3         | Speed Search                                   | H7         | Virtual Inputs / Outputs     |
| b4         | Timer Function                                 | L1         | Motor Protection             |
| b5         | PID Control                                    | L2         | Power Loss Ride Through      |
| b6         | Dwell Function                                 | L3         | Stall Prevention             |
| b7         | Droop Control                                  | L4         | Speed Detection              |
| b8         | Energy Saving                                  | L5         | Fault Restart                |
| b9         | Zero Servo                                     | L6         | Torque Detection             |
| C1         | Accel & Decel Time                             | L7         | Torque Limit                 |
| C2         | S-Curve Characteristics                        | L8         | Drive Protection             |
| C3         | Slip Compensation                              | L9         | Drive Protection 2           |
| C4         | Torque Compensation                            | n1         | Hunting Prevention           |
| C5         | Auto Speed Regulator (ASR)                     | n2         | Auto Freq Regulator (AFR)    |
| C6         | Duty & Carrier Frequency                       | n3         | High Slip/Overexcite Braking |
| d1         | Frequency Reference                            | n4         | Adv Open Loop Vector Tune    |
| d2         | Reference Limits                               | n5         | Feed Forward Control         |
| d3         | Jump Frequency                                 | n6         | Online Tuning                |
| d4         | Frequency Ref Up/Down & Hold                   | n7         | EZ Drive                     |
| d5         | Torque Control                                 | n8         | PM Motor Control Tuning      |
| d6         | Field Weakening /Forcing                       | o1         | Keypad Display               |
| d7         | Offset Frequency                               | o2         | Keypad Operation             |
| E1         | V/f Pattern for Motor 1                        | o3         | Copy Keypad Function         |
| E2         | Motor Parameters                               | o4         | Maintenance Monitors         |
| E3         | V/f Pattern for Motor 2                        | o5         | Log Function                 |
| E4         | Motor 2 Parameters                             | q          | DriveWorksEZ Parameters      |
| E5         | PM Motor Settings                              | r          | DriveWorksEZ Connections     |
| E9         | Motor Setting                                  | T0         | Tuning Mode Selection        |
| F1         | PG Option Setup (Encoder)                      | T1         | InductionMotor Auto-Tuning   |
| F2         | Analog Input Option                            | T2         | PM Motor Auto-Tuning         |
| F3         | Digital Input Option                           | T3         | ASR and Inertia Tuning       |
| F4         | Analog Output Option                           | T4         | EZ Tuning                    |
| F5         | Digital Output Option                          | U1         | Operation Status Monitors    |
| F6         | Communication Options                          | U2         | Fault Trace                  |
| F7         | Ethernet Options                               | U3         | Fault History                |
| H1         | Digital Inputs                                 | U4         | Maintenance Monitors         |
| H2         | Digital Outputs                                | U5         | PID Monitors                 |

### 1.3 Parameter Groups

| Parameters | Name                      |
|------------|---------------------------|
| U6         | Operation Status Monitors |

| Parameters | Name                  |
|------------|-----------------------|
| U8         | DriveWorksEZ Monitors |

## 1.4 A: Initialization Parameters

### ◆ A1: Initialization

| No. (Hex.)             | Name                     | Description   | Default (Range)       | Ref. |
|------------------------|--------------------------|---|-----------------------|------|
| A1-00<br>(0100)<br>RUN | Language Selection       | <p><b>V/f</b> <b>CL-V/f</b> <b>OLV</b> <b>CLV</b> <b>AOLV</b> <b>OLV/PM</b> <b>AOLV/PM</b> <b>CLV/PM</b> <b>EZOLV</b></p> <p>Sets the language for the LCD keypad.</p> <p><b>Note:</b><br/>When you initialize the drive with parameter <i>A1-03 [Initialize Parameters]</i>, the drive will not reset this parameter.</p> <p>0 : English<br/>1 : Japanese<br/>2 : German<br/>3 : French<br/>4 : Italian<br/>5 : Spanish<br/>6 : Portuguese<br/>7 : Chinese<br/>8 : Czech<br/>9 : Russian<br/>10 : Turkish<br/>11 : Polish<br/>12 : Greek</p> | 0<br>(0 - 12)         | 185  |
| A1-01<br>(0101)<br>RUN | Access Level Selection   | <p><b>V/f</b> <b>CL-V/f</b> <b>OLV</b> <b>CLV</b> <b>AOLV</b> <b>OLV/PM</b> <b>AOLV/PM</b> <b>CLV/PM</b> <b>EZOLV</b></p> <p>Sets user access to parameters. The access level controls which parameters the keypad will display, and which parameters the user can set.</p> <p>0 : Operation Only<br/>1 : User Parameters<br/>2 : Advanced Level<br/>3 : Expert Level</p>   | 2<br>(0 - 3)          | 185  |
| A1-02<br>(0102)        | Control Method Selection | <p><b>V/f</b> <b>CL-V/f</b> <b>OLV</b> <b>CLV</b> <b>AOLV</b> <b>OLV/PM</b> <b>AOLV/PM</b> <b>CLV/PM</b> <b>EZOLV</b></p> <p>Sets the control method for the drive application and the motor.</p> <p>0 : V/f Control<br/>1 : V/f Control with Encoder<br/>2 : Open Loop Vector<br/>3 : Closed Loop Vector<br/>4 : Advanced Open Loop Vector<br/>5 : PM Open Loop Vector<br/>6 : PM Advanced Open Loop Vector<br/>7 : PM Closed Loop Vector<br/>8 : EZ Vector Control</p>  | 2<br>(0 - 8)          | 186  |
| A1-03<br>(0103)        | Initialize Parameters    | <p><b>V/f</b> <b>CL-V/f</b> <b>OLV</b> <b>CLV</b> <b>AOLV</b> <b>OLV/PM</b> <b>AOLV/PM</b> <b>CLV/PM</b> <b>EZOLV</b></p> <p>Sets parameters to default values.</p> <p>0 : No Initialization<br/>1110 : User Initialization<br/>2220 : 2-Wire Initialization<br/>3330 : 3-Wire Initialization</p>   | 0<br>(0 - 3330)       | 187  |
| A1-04<br>(0104)        | Password                 | <p><b>V/f</b> <b>CL-V/f</b> <b>OLV</b> <b>CLV</b> <b>AOLV</b> <b>OLV/PM</b> <b>AOLV/PM</b> <b>CLV/PM</b> <b>EZOLV</b></p> <p>Entry point for the password set in <i>A1-05 [Password Setting]</i>. The user can view the settings of parameters that are locked without entering the password. Enter the correct password in this parameter to change parameter settings.</p>  | 0000<br>(0000 - 9999) | 188  |
| A1-05<br>(0105)        | Password Setting         | <p><b>V/f</b> <b>CL-V/f</b> <b>OLV</b> <b>CLV</b> <b>AOLV</b> <b>OLV/PM</b> <b>AOLV/PM</b> <b>CLV/PM</b> <b>EZOLV</b></p> <p>Set the password to lock parameters and prevent changes to parameter settings. Enter the correct password in <i>A1-04 [Password]</i> to unlock parameters and accept changes.</p>  | 0000<br>(0000 - 9999) | 189  |
| A1-06<br>(0127)        | Application Preset       | <p><b>V/f</b> <b>CL-V/f</b> <b>OLV</b> <b>CLV</b> <b>AOLV</b> <b>OLV/PM</b> <b>AOLV/PM</b> <b>CLV/PM</b> <b>EZOLV</b></p> <p>Sets the drive to operate in selected application conditions.</p> <p>0 : General-purpose<br/>1 : Water Supply Pump 2<br/>2 : Conveyor<br/>3 : Exhaust Fan<br/>4 : HVAC Fan<br/>5 : Air Compressor</p>  | 0<br>(0 - 5)          | 189  |



| No. (Hex.)                | Name                            | Description   | Default (Range)    | Ref. |
|---------------------------|---------------------------------|---|--------------------|------|
| A1-07<br>(0128)           | DriveWorksEZ Function Selection | <p><b>V/f</b> <b>CL-V/f</b> <b>OLV</b> <b>CLV</b> <b>AOLV</b> <b>OLV/PM</b> <b>AOLV/PM</b> <b>CLV/PM</b> <b>EZOLV</b></p> <p>Sets the drive to operate with DriveWorksEZ.<br/>           0 : DWEZ Disabled<br/>           1 : DWEZ Enabled<br/>           2 : Enabled/Disabled wDigital Input</p> | 0<br>(0 - 2)       | 202  |
| A1-11<br>(111D)<br>Expert | Firmware Update Lock            | <p><b>V/f</b> <b>CL-V/f</b> <b>OLV</b> <b>CLV</b> <b>AOLV</b> <b>OLV/PM</b> <b>AOLV/PM</b> <b>CLV/PM</b> <b>EZOLV</b></p> <p>Protects the drive firmware. Enabling the protection makes it impossible to update the drive firmware.<br/>           0 : No<br/>           1 : Yes</p>              | 0<br>(0, 1)        | 202  |
| A1-12<br>(1564)           | Bluetooth ID                    | <p><b>V/f</b> <b>CL-V/f</b> <b>OLV</b> <b>CLV</b> <b>AOLV</b> <b>OLV/PM</b> <b>AOLV/PM</b> <b>CLV/PM</b> <b>EZOLV</b></p> <p>Sets the password necessary to use Bluetooth to control the drive with a smartphone or tablet.</p>   | -<br>(0000 - 9999) | 203  |

## ◆ A2: User Parameters

| No. (Hex.)                      | Name                          | Description  | Default (Range)   | Ref. |
|---------------------------------|-------------------------------|--|---|------|
| A2-01 to A2-32<br>(0106 - 0125) | User Parameters 1 to 32       | <p><b>V/f</b> <b>CL-V/f</b> <b>OLV</b> <b>CLV</b> <b>AOLV</b> <b>OLV/PM</b> <b>AOLV/PM</b> <b>CLV/PM</b> <b>EZOLV</b></p> <p>You can select a maximum of 32 parameters for the drive and set them to parameters <i>A2-01 to A2-32</i>. The [User Parameters] section of the keypad main menu shows the set parameters. You can immediately access these set parameters.</p> <p><b>Note:</b><br/>           Settings for <i>A2-01 to A2-32</i> change when the <i>A1-06</i> [Application Preset] value changes.</p> | Parameters in General-Purpose Setup Mode<br>(Determined by A1-06) | 203  |
| A2-33<br>(0126)                 | User Parameter Auto Selection | <p><b>V/f</b> <b>CL-V/f</b> <b>OLV</b> <b>CLV</b> <b>AOLV</b> <b>OLV/PM</b> <b>AOLV/PM</b> <b>CLV/PM</b> <b>EZOLV</b></p> <p>Sets the automatic save feature for changes to parameters <i>A2-17 to A2-32</i> [User Parameters 17 to 32].<br/>           0 : Disabled: Manual Entry Required<br/>           1 : Enabled: Auto Save Recent Params</p>  | Determined by A1-06<br>(0, 1)                                     | 203  |

## 1.5 b: Application

### ◆ b1: Operation Mode Selection

| No.<br>(Hex.)             | Name                            | Description   | Default<br>(Setting Range) | Ref. |
|---------------------------|---------------------------------|---|----------------------------|------|
| b1-01<br>(0180)           | Frequency Reference Selection 1 | <p><b>V/f</b> <b>CL-V/f</b> <b>OLV</b> <b>CLV</b> <b>AOLV</b> <b>OLV/PM</b> <b>AOLV/PM</b> <b>CLV/PM</b> <b>EZOLV</b></p> <p>Sets the input method for the frequency reference.</p> <p>0 : Keypad<br/>1 : Analog Input<br/>2 : Memobus/Modbus Communications<br/>3 : Option PCB<br/>4 : Pulse Train Input</p>   | 1<br>(0 - 4)               | 204  |
| b1-02<br>(0181)           | Run Command Selection 1         | <p><b>V/f</b> <b>CL-V/f</b> <b>OLV</b> <b>CLV</b> <b>AOLV</b> <b>OLV/PM</b> <b>AOLV/PM</b> <b>CLV/PM</b> <b>EZOLV</b></p> <p>Sets the input method for the Run command.</p> <p>0 : Keypad<br/>1 : Digital Input<br/>2 : Memobus/Modbus Communications<br/>3 : Option PCB</p>  | 1<br>(0 - 3)               | 206  |
| b1-03<br>(0182)           | Stopping Method Selection       | <p><b>V/f</b> <b>CL-V/f</b> <b>OLV</b> <b>CLV</b> <b>AOLV</b> <b>OLV/PM</b> <b>AOLV/PM</b> <b>CLV/PM</b> <b>EZOLV</b></p> <p>Sets the method to stop the motor after removing a Run command or entering a Stop command.</p> <p><b>Note:</b><br/>When A1-02 = 3, 4, 5, 6, 7, 8 [Control Method Selection = CLV, AOLV, OLV/PM, AOLV/PM, CLV/PM, EZOLV], the setting range is 0, 1, 3.</p> <p>0 : Ramp to Stop<br/>1 : Coast to Stop<br/>2 : DC Injection Braking to Stop<br/>3 : Coast to Stop with Timer</p> | 0<br>(0 - 3)               | 207  |
| b1-04<br>(0183)           | Reverse Operation Selection     | <p><b>V/f</b> <b>CL-V/f</b> <b>OLV</b> <b>CLV</b> <b>AOLV</b> <b>OLV/PM</b> <b>AOLV/PM</b> <b>CLV/PM</b> <b>EZOLV</b></p> <p>Sets the reverse operation function. Disable reverse operation in fan or pump applications where reverse rotation is dangerous.</p> <p>0 : Reverse Enabled<br/>1 : Reverse Disabled</p>  | 0<br>(0, 1)                | 210  |
| b1-05<br>(0184)           | Operation Below Minimum Freq    | <p><b>V/f</b> <b>CL-V/f</b> <b>OLV</b> <b>CLV</b> <b>AOLV</b> <b>OLV/PM</b> <b>AOLV/PM</b> <b>CLV/PM</b> <b>EZOLV</b></p> <p>Sets the drive operation when the frequency reference decreases to less than the value set in E1-09 [Minimum Output Frequency].</p> <p>0 : Operate at Frequency Reference<br/>1 : Coast to Stop<br/>2 : Operate at Minimum Frequency<br/>3 : Operate at Zero Speed</p>   | 0<br>(0 - 3)               | 210  |
| b1-06<br>(0185)           | Digital Input Reading           | <p><b>V/f</b> <b>CL-V/f</b> <b>OLV</b> <b>CLV</b> <b>AOLV</b> <b>OLV/PM</b> <b>AOLV/PM</b> <b>CLV/PM</b> <b>EZOLV</b></p> <p>Sets the number of times that the drive reads the sequence input command to prevent malfunction due to noise.</p> <p>0 : Single Scan<br/>1 : Double Scan</p>   | 1<br>(0, 1)                | 211  |
| b1-07<br>(0186)           | LOCAL/REMOTE Run Selection      | <p><b>V/f</b> <b>CL-V/f</b> <b>OLV</b> <b>CLV</b> <b>AOLV</b> <b>OLV/PM</b> <b>AOLV/PM</b> <b>CLV/PM</b> <b>EZOLV</b></p> <p>Sets drive response to an existing Run command when the drive receives a second Run command from a different location.</p> <p>0 : Disregard Existing RUN Command<br/>1 : Accept Existing RUN Command</p>   | 0<br>(0, 1)                | 212  |
| b1-08<br>(0187)           | Run Command Select in PRG Mode  | <p><b>V/f</b> <b>CL-V/f</b> <b>OLV</b> <b>CLV</b> <b>AOLV</b> <b>OLV/PM</b> <b>AOLV/PM</b> <b>CLV/PM</b> <b>EZOLV</b></p> <p>Sets the conditions for the drive to accept a Run command entered from an external source when using the keypad to set parameters.</p> <p>0 : Disregard RUN while Programming<br/>1 : Accept RUN while Programming<br/>2 : Allow Programming Only at Stop</p>  | 0<br>(0 - 2)               | 212  |
| b1-09<br>(0188)<br>Expert | L/R Switching during Operation  | <p><b>V/f</b> <b>CL-V/f</b> <b>OLV</b> <b>CLV</b> <b>AOLV</b> <b>OLV/PM</b> <b>AOLV/PM</b> <b>CLV/PM</b> <b>EZOLV</b></p> <p>Sets the function that lets the drive switch between LOCAL and REMOTE Modes using <b>LO/RE</b> during operation.</p> <p>0 : No<br/>1 : Yes</p>   | 0<br>(0, 1)                | 213  |

| No. (Hex.)          | Name                            | Description   | Default (Setting Range)     | Ref. |
|---------------------|---------------------------------|---|-----------------------------|------|
| b1-14 (01C3)        | Phase Order Selection           | <b>V/f</b> <b>CL-V/f</b> <b>OLV</b> <b>CLV</b> <b>AOLV</b> <b>OLV/PM</b> <b>AOLV/PM</b> <b>CLV/PM</b> <b>EZOLV</b><br>Sets the phase order for output terminals U/T1, V/T2, and W/T3. This parameter can align the Forward Run command from the drive and the forward direction of the motor without changing wiring.<br>0 : Standard<br>1 : Switch Phase Order                 | 0<br>(0, 1)                 | 213  |
| b1-15 (01C4)        | Frequency Reference Selection 2 | <b>V/f</b> <b>CL-V/f</b> <b>OLV</b> <b>CLV</b> <b>AOLV</b> <b>OLV/PM</b> <b>AOLV/PM</b> <b>CLV/PM</b> <b>EZOLV</b><br>Sets the input method for frequency reference 2.<br>0 : Keypad<br>1 : Digital Input<br>2 : Memobus/Modbus Communications<br>3 : Option PCB<br>4 : Pulse Train Input   | 0<br>(0 - 4)                | 213  |
| b1-16 (01C5)        | Run Command Selection 2         | <b>V/f</b> <b>CL-V/f</b> <b>OLV</b> <b>CLV</b> <b>AOLV</b> <b>OLV/PM</b> <b>AOLV/PM</b> <b>CLV/PM</b> <b>EZOLV</b><br>Sets the input method for Run Command 2 when the user switches the control circuit terminals ON/OFF to change the Run command source.<br>0 : Keypad<br>1 : Digital Input<br>2 : Memobus/Modbus Communications<br>3 : Option PCB                           | 0<br>(0 - 3)                | 215  |
| b1-17 (01C6)        | Run Command at Power Up         | <b>V/f</b> <b>CL-V/f</b> <b>OLV</b> <b>CLV</b> <b>AOLV</b> <b>OLV/PM</b> <b>AOLV/PM</b> <b>CLV/PM</b> <b>EZOLV</b><br>Sets drive response when energizing a drive that has an external Run command. Set this parameter in applications where energizing or de-energizing the drive enables the Run command.<br>0 : Disregard Existing RUN Command<br>1 : Enable                 | 0<br>(0, 1)                 | 216  |
| b1-21 (0748) Expert | CLV Start Selection             | <b>V/f</b> <b>CL-V/f</b> <b>OLV</b> <b>CLV</b> <b>AOLV</b> <b>OLV/PM</b> <b>AOLV/PM</b> <b>CLV/PM</b> <b>EZOLV</b><br>Sets the conditions for the drive to accept a Run command if A1-02 = 3, 7 [Control Method Selection = CLV, CLV/PM]. Usually it is not necessary to change this setting.<br>0 : Reject RUN if b2-01 < U1-05 < E1-09<br>1 : Accept RUN Command at Any Speed | 0<br>(0, 1)                 | 216  |
| b1-35 (1117) Expert | Digital Input Deadband Time     | <b>V/f</b> <b>CL-V/f</b> <b>OLV</b> <b>CLV</b> <b>AOLV</b> <b>OLV/PM</b> <b>AOLV/PM</b> <b>CLV/PM</b> <b>EZOLV</b><br>Sets the deadband time for MFDIs.   | 0.0 ms<br>(0.0 to 100.0 ms) | 217  |

## ◆ b2: DC Injection Braking and Short Circuit Braking

| No. (Hex.)   | Name                             | Description  | Default (Range)  | Ref. |
|--------------|----------------------------------|--|--|------|
| b2-01 (0189) | DC Injection/Zero SpeedThreshold | <b>V/f</b> <b>CL-V/f</b> <b>OLV</b> <b>CLV</b> <b>AOLV</b> <b>OLV/PM</b> <b>AOLV/PM</b> <b>CLV/PM</b> <b>EZOLV</b><br>Sets the frequency to start DC Injection Braking, Short Circuit Braking, and Zero Servo.<br><b>Note:</b><br>This parameter is available when b1-03 = 0 [Stopping Method Selection = Ramp to Stop]. | Determined by A1-02<br>(0.0 - 10.0 Hz)                                   | 217  |
| b2-02 (018A) | DC Injection Braking Current     | <b>V/f</b> <b>CL-V/f</b> <b>OLV</b> <b>CLV</b> <b>AOLV</b> <b>OLV/PM</b> <b>AOLV/PM</b> <b>CLV/PM</b> <b>EZOLV</b><br>Sets the DC Injection Braking current as a percentage of the drive rated current.  | 50%<br>(0 - 100%)  | 218  |
| b2-03 (018B) | DC Inject Braking Time at Start  | <b>V/f</b> <b>CL-V/f</b> <b>OLV</b> <b>CLV</b> <b>AOLV</b> <b>OLV/PM</b> <b>AOLV/PM</b> <b>CLV/PM</b> <b>EZOLV</b><br>Sets the DC Injection Braking Time at stop. Sets the time of Zero Speed Control at start if A1-02 = 3, 7 [Control Method Selection = CLV, CLV/PM].   | A1-02 = 4: 0.03 s<br>Other than A1-02 = 4:<br>0.00 s<br>(0.00 - 10.00 s) | 218  |
| b2-04 (018C) | DC Inject Braking Time at Stop   | <b>V/f</b> <b>CL-V/f</b> <b>OLV</b> <b>CLV</b> <b>AOLV</b> <b>OLV/PM</b> <b>AOLV/PM</b> <b>CLV/PM</b> <b>EZOLV</b><br>Sets the DC Injection Braking Time at stop. Sets the time of Zero Speed Control at stop if A1-02 = 3, 7 [Control Method Selection = CLV, CLV/PM].  | Determined by A1-02<br>(0.00 - 10.00 s)                                  | 219  |
| b2-08 (0190) | Magnetic Flux Compensation Value | <b>V/f</b> <b>CL-V/f</b> <b>OLV</b> <b>CLV</b> <b>AOLV</b> <b>OLV/PM</b> <b>AOLV/PM</b> <b>CLV/PM</b> <b>EZOLV</b><br>Sets how much current the drive injects when DC Injection Braking at Start starts (Initial Excitation) as a percentage of E2-03 [Motor No-Load Current].   | 0%<br>(0 - 1000%)  | 219  |
| b2-12 (01BA) | Short Circuit Brake Time @ Start | <b>V/f</b> <b>CL-V/f</b> <b>OLV</b> <b>CLV</b> <b>AOLV</b> <b>OLV/PM</b> <b>AOLV/PM</b> <b>CLV/PM</b> <b>EZOLV</b><br>Sets the Short Circuit Braking time at start.  | 0.00 s<br>(0.00 - 25.50 s)   | 219  |

## 1.5 b: Application

| No. (Hex.)   | Name                            | Description   | Default (Range)   | Ref. |
|--------------|---------------------------------|---|---|------|
| b2-13 (01BB) | Short Circuit Brake Time @ Stop | <input type="checkbox"/> V/f <input type="checkbox"/> CL-V/f <input type="checkbox"/> OLV <input type="checkbox"/> CLV <input type="checkbox"/> AOLV <input checked="" type="checkbox"/> OLV/PM <input checked="" type="checkbox"/> AOLV/PM <input type="checkbox"/> CLV/PM <input checked="" type="checkbox"/> EZOLV<br>Sets the Short Circuit Braking time at stop.   | A1-02 = 8: 0.00 s<br>Other than A1-02 = 8: 0.50 s<br>(0.00 - 25.50 s) | 220  |
| b2-18 (0177) | Short Circuit Braking Current   | <input type="checkbox"/> V/f <input type="checkbox"/> CL-V/f <input type="checkbox"/> OLV <input type="checkbox"/> CLV <input type="checkbox"/> AOLV <input checked="" type="checkbox"/> OLV/PM <input checked="" type="checkbox"/> AOLV/PM <input type="checkbox"/> CLV/PM <input checked="" type="checkbox"/> EZOLV<br>Sets the Short Circuit Braking Current as a percentage of the motor rated current.<br><b>Note:</b><br>Parameter A1-02 [Control Method Selection] selects which parameter is the motor rated current.<br>• A1-02 = 5, 6 [OLV/PM, AOLV/PM]: E5-03 [PM Motor Rated Current (FLA)]<br>• A1-02 = 8 [EZOLV]: E9-06 [Motor Rated Current (FLA)] | 100.0%<br>(0.0 - 200.0%)  | 220  |

### ◆ b3: Speed Search

| No. (Hex.)          | Name                             | Description   | Default (Range)  | Ref. |
|---------------------|----------------------------------|---|--|------|
| b3-01 (0191)        | Speed Search at Start Selection  | <input type="checkbox"/> V/f <input type="checkbox"/> CL-V/f <input type="checkbox"/> OLV <input type="checkbox"/> CLV <input type="checkbox"/> AOLV <input checked="" type="checkbox"/> OLV/PM <input checked="" type="checkbox"/> AOLV/PM <input type="checkbox"/> CLV/PM <input checked="" type="checkbox"/> EZOLV<br>Sets the Speed Search at Start function where the drive will perform Speed Search with each Run command.<br>0 : No<br>1 : Yes  | Determined by A1-02<br>(0, 1)  | 224  |
| b3-02 (0192)        | SpeedSearch Deactivation Current | <input type="checkbox"/> V/f <input type="checkbox"/> CL-V/f <input type="checkbox"/> OLV <input type="checkbox"/> CLV <input type="checkbox"/> AOLV <input checked="" type="checkbox"/> OLV/PM <input checked="" type="checkbox"/> AOLV/PM <input type="checkbox"/> CLV/PM <input checked="" type="checkbox"/> EZOLV<br>Sets the current level that stops Speed Search as a percentage of the drive rated output current. Usually it is not necessary to change this setting.  | Determined by A1-02<br>(0 - 200%)  | 224  |
| b3-03 (0193)        | Speed Search Deceleration Time   | <input type="checkbox"/> V/f <input type="checkbox"/> CL-V/f <input type="checkbox"/> OLV <input type="checkbox"/> CLV <input type="checkbox"/> AOLV <input checked="" type="checkbox"/> OLV/PM <input checked="" type="checkbox"/> AOLV/PM <input type="checkbox"/> CLV/PM <input checked="" type="checkbox"/> EZOLV<br>Sets the deceleration time during Speed Search operation. Set the length of time to decelerate from the maximum output frequency to the minimum output frequency.<br><b>Note:</b><br>If A1-02 = 8 [Control Method Selection = EZOLV], this parameter takes effect only in Expert Mode. | 2.0 s<br>(0.1 - 10.0 s)  | 224  |
| b3-04 (0194)        | V/f Gain during Speed Search     | <input type="checkbox"/> V/f <input type="checkbox"/> CL-V/f <input type="checkbox"/> OLV <input type="checkbox"/> CLV <input type="checkbox"/> AOLV <input checked="" type="checkbox"/> OLV/PM <input checked="" type="checkbox"/> AOLV/PM <input type="checkbox"/> CLV/PM <input checked="" type="checkbox"/> EZOLV<br>Sets the ratio used to reduce the V/f during searches to reduce the output current during speed searches.  | Determined by o2-04<br>(10 - 100)  | 225  |
| b3-05 (0195)        | Speed Search Delay Time          | <input type="checkbox"/> V/f <input type="checkbox"/> CL-V/f <input type="checkbox"/> OLV <input type="checkbox"/> CLV <input type="checkbox"/> AOLV <input checked="" type="checkbox"/> OLV/PM <input checked="" type="checkbox"/> AOLV/PM <input type="checkbox"/> CLV/PM <input checked="" type="checkbox"/> EZOLV<br>Sets the Speed Search delay time to activate a magnetic contactor installed between the drive and motor.   | 0.2 s<br>(0.0 - 100.0 s)   | 225  |
| b3-06 (0196) Expert | Speed Estimation Current Level 1 | <input type="checkbox"/> V/f <input type="checkbox"/> CL-V/f <input type="checkbox"/> OLV <input type="checkbox"/> CLV <input type="checkbox"/> AOLV <input checked="" type="checkbox"/> OLV/PM <input checked="" type="checkbox"/> AOLV/PM <input type="checkbox"/> CLV/PM <input checked="" type="checkbox"/> EZOLV<br>Sets the level of current that flows to the motor during Speed Estimation Speed Search as a coefficient of the motor rated current. Usually it is not necessary to change this setting.  | Determined by o2-04<br>(0.0 - 2.0)   | 225  |
| b3-07 (0197) Expert | Speed Estimation Current Level 2 | <input type="checkbox"/> V/f <input type="checkbox"/> CL-V/f <input type="checkbox"/> OLV <input type="checkbox"/> CLV <input type="checkbox"/> AOLV <input checked="" type="checkbox"/> OLV/PM <input checked="" type="checkbox"/> AOLV/PM <input type="checkbox"/> CLV/PM <input checked="" type="checkbox"/> EZOLV<br>Sets the level of current that flows to the motor during Speed Estimation Speed Search as a coefficient of E2-03 [Motor No-Load Current] or E4-03 [Motor 2 Rated No-Load Current]. Usually it is not necessary to change this setting.   | 1.0<br>(0.0 - 3.0)   | 225  |
| b3-08 (0198)        | Speed Estimation ACR P Gain      | <input type="checkbox"/> V/f <input type="checkbox"/> CL-V/f <input type="checkbox"/> OLV <input type="checkbox"/> CLV <input type="checkbox"/> AOLV <input checked="" type="checkbox"/> OLV/PM <input checked="" type="checkbox"/> AOLV/PM <input type="checkbox"/> CLV/PM <input checked="" type="checkbox"/> EZOLV<br>Sets the proportional gain for the automatic current regulator during Speed Estimation Speed Search. Also adjusts speed search responsiveness. Usually it is not necessary to change this setting.   | Determined by A1-02 and o2-04<br>(0.00 - 6.00)                             | 225  |
| b3-09 (0199)        | Speed Estimation ACR I Time      | <input type="checkbox"/> V/f <input type="checkbox"/> CL-V/f <input type="checkbox"/> OLV <input type="checkbox"/> CLV <input type="checkbox"/> AOLV <input checked="" type="checkbox"/> OLV/PM <input checked="" type="checkbox"/> AOLV/PM <input type="checkbox"/> CLV/PM <input checked="" type="checkbox"/> EZOLV<br>Sets the integral time for the automatic current regulator during Speed Estimation Speed Search. Also adjusts speed search responsiveness. Usually it is not necessary to change this setting.   | Determined by A1-02 if A1-02 ≠ 5<br>20.0 if A1-02 = 5<br>(0.0 - 1000.0 ms) | 226  |
| b3-10 (019A) Expert | Speed Estimation Detection Gain  | <input type="checkbox"/> V/f <input type="checkbox"/> CL-V/f <input type="checkbox"/> OLV <input type="checkbox"/> CLV <input type="checkbox"/> AOLV <input checked="" type="checkbox"/> OLV/PM <input checked="" type="checkbox"/> AOLV/PM <input type="checkbox"/> CLV/PM <input checked="" type="checkbox"/> EZOLV<br>Sets the gain to correct estimated frequencies from Speed Estimation Speed Search.   | 1.05<br>(1.00 - 1.20)  | 226  |

| No. (Hex.)          | Name                             | Description  | Default (Range)                      | Ref. |
|---------------------|----------------------------------|--|--------------------------------------|------|
| b3-14 (019E)        | Bi-directional Speed Search      | <p><input type="checkbox"/> V/f <input type="checkbox"/> CL-V/f <input type="checkbox"/> OLV <input type="checkbox"/> CLV <input type="checkbox"/> AOLV <input type="checkbox"/> OLV/PM <input type="checkbox"/> AOLV/PM <input type="checkbox"/> CLV/PM <input type="checkbox"/> EZOLV</p> <p>Sets the direction of Speed Search to the direction of the frequency reference or in the motor rotation direction as detected by the drive.</p> <p>0 : No<br/>1 : Yes</p> <p><b>Note:</b></p> <ul style="list-style-type: none"> <li>Refer to page 125 for information on the initial value of <i>b3-14</i> [Bi-directional Speed Search] that applies when you set the following. <ul style="list-style-type: none"> <li>–<i>A1-02</i> = 0, 2, 8 [Control Method Selection = V/f, OLV, EZOLV]</li> <li>–<i>E9-01</i> = 0 [Motor Type Selection = Induction (IM)]</li> <li>–<i>b3-24</i> = 1 [Speed Search Method Selection = Speed Estimation Speed Search]</li> </ul> </li> <li>The initial value of <i>b3-14</i> is 0 when you set the following. <ul style="list-style-type: none"> <li>–<i>A1-02</i> = 0, 2, 8</li> <li>–<i>E9-01</i> = 0</li> <li>–<i>b3-24</i> = 2 [Current Detection 2]</li> </ul> </li> <li>Refer to page 125 for information on the initial value of <i>b3-14</i> that applies when you set the following. <ul style="list-style-type: none"> <li>–<i>A1-02</i> = 1, 4, 8 [CL-V/f, AOLV, EZOLV]</li> <li>–<i>E9-01</i> = 1, 2 [Permanent Magnet (PM), Synchronous Reluctance (SynRM)]</li> </ul> </li> <li>When you change <i>A1-02</i>, <i>b3-24</i>, and <i>E9-01</i>, set <i>b3-14</i> as well.</li> </ul> | Determined by A1-02 and b3-24 (0, 1) | 226  |
| b3-17 (01F0) Expert | Speed Est Retry Current Level    | <p><input type="checkbox"/> V/f <input type="checkbox"/> CL-V/f <input type="checkbox"/> OLV <input type="checkbox"/> CLV <input type="checkbox"/> AOLV <input type="checkbox"/> OLV/PM <input type="checkbox"/> AOLV/PM <input type="checkbox"/> CLV/PM <input type="checkbox"/> EZOLV</p> <p>Sets the current level for the search retry function in Speed Estimation Speed Search as a percentage where drive rated current is a setting value of 100%.</p>   | 150% (0 - 200%)                      | 226  |
| b3-18 (01F1) Expert | Speed Est Retry Detection Time   | <p><input type="checkbox"/> V/f <input type="checkbox"/> CL-V/f <input type="checkbox"/> OLV <input type="checkbox"/> CLV <input type="checkbox"/> AOLV <input type="checkbox"/> OLV/PM <input type="checkbox"/> AOLV/PM <input type="checkbox"/> CLV/PM <input type="checkbox"/> EZOLV</p> <p>Sets the length of time that the drive will wait to retry Speed Estimation Speed Search when too much current flow stopped the Speed Search.</p>  | 0.10 s (0.00 - 1.00 s)               | 227  |
| b3-19 (01F2)        | Speed Search Restart Attempts    | <p><input type="checkbox"/> V/f <input type="checkbox"/> CL-V/f <input type="checkbox"/> OLV <input type="checkbox"/> CLV <input type="checkbox"/> AOLV <input type="checkbox"/> OLV/PM <input type="checkbox"/> AOLV/PM <input type="checkbox"/> CLV/PM <input type="checkbox"/> EZOLV</p> <p>Sets the number of times to restart Speed Search if Speed Search does not complete.</p>   | 3 times (0 - 10 times)               | 227  |
| b3-24 (01C0)        | Speed Search Method Selection    | <p><input type="checkbox"/> V/f <input type="checkbox"/> CL-V/f <input type="checkbox"/> OLV <input type="checkbox"/> CLV <input type="checkbox"/> AOLV <input type="checkbox"/> OLV/PM <input type="checkbox"/> AOLV/PM <input type="checkbox"/> CLV/PM <input type="checkbox"/> EZOLV</p> <p>Sets the Speed Search method when starting the motor or when restoring power after a momentary power loss.</p> <p><b>Note:</b></p> <ul style="list-style-type: none"> <li>If <i>A1-02</i> = 8 [Control Method Selection = EZOLV], the default settings differ depending on the setting of <i>E9-01</i> [Motor Type Selection] and the drive model <ul style="list-style-type: none"> <li>–<i>E9-01</i> = 0 [Induction (IM)] <ul style="list-style-type: none"> <li>–2004 to 2313, 4002 to 4302: 1</li> <li>–2360, 2415, 4371 to 4720: 2</li> </ul> </li> <li>–<i>E9-01</i> = 1, 2 [Permanent Magnet (PM), Synchronous Reluctance (SynRM)]: 1</li> </ul> </li> <li>When you set <i>b3-24</i>, <i>b3-14</i> [Bi-directional Speed Search] is initialized. Set <i>b3-14</i> after you set <i>b3-24</i>.</li> </ul> <p>1 : Speed Estimation<br/>2 : Current Detection 2</p>   | 2 (1, 2)                             | 227  |
| b3-25 (01C8) Expert | Speed Search Wait Time           | <p><input type="checkbox"/> V/f <input type="checkbox"/> CL-V/f <input type="checkbox"/> OLV <input type="checkbox"/> CLV <input type="checkbox"/> AOLV <input type="checkbox"/> OLV/PM <input type="checkbox"/> AOLV/PM <input type="checkbox"/> CLV/PM <input type="checkbox"/> EZOLV</p> <p>Sets the length of time the drive will wait to start the Speed Search Retry function.</p>   | 0.5 s (0.0 - 30.0 s)                 | 227  |
| b3-26 (01C7) Expert | Direction Determination Level    | <p><input type="checkbox"/> V/f <input type="checkbox"/> CL-V/f <input type="checkbox"/> OLV <input type="checkbox"/> CLV <input type="checkbox"/> AOLV <input type="checkbox"/> OLV/PM <input type="checkbox"/> AOLV/PM <input type="checkbox"/> CLV/PM <input type="checkbox"/> EZOLV</p> <p>Sets the level to find the motor rotation direction. Increase the value if the drive cannot find the direction.</p>   | 1000 (40 to 60000)                   | 228  |
| b3-27 (01C9) Expert | Speed Search RUN/BB Priority     | <p><input type="checkbox"/> V/f <input type="checkbox"/> CL-V/f <input type="checkbox"/> OLV <input type="checkbox"/> CLV <input type="checkbox"/> AOLV <input type="checkbox"/> OLV/PM <input type="checkbox"/> AOLV/PM <input type="checkbox"/> CLV/PM <input type="checkbox"/> EZOLV</p> <p>Sets the conditions necessary to start Speed Search.</p> <p>0 : SS Only if RUN Applied Before BB<br/>1 : SS Regardless of RUN/BB Sequence</p>   | 0 (0, 1)                             | 228  |
| b3-29 (077C) Expert | Speed Search Back-EMF Threshold  | <p><input type="checkbox"/> V/f <input type="checkbox"/> CL-V/f <input type="checkbox"/> OLV <input type="checkbox"/> CLV <input type="checkbox"/> AOLV <input type="checkbox"/> OLV/PM <input type="checkbox"/> AOLV/PM <input type="checkbox"/> CLV/PM <input type="checkbox"/> EZOLV</p> <p>Sets the induced voltage for motors that use Speed Search. The drive will start Speed Search when the motor induced voltage level is the same as the setting value. Usually it is not necessary to change this setting.</p>   | 10% (0 - 10%)                        | 228  |
| b3-31 (0BC0) Expert | Spd Search Current Reference Lvl | <p><input type="checkbox"/> V/f <input type="checkbox"/> CL-V/f <input type="checkbox"/> OLV <input type="checkbox"/> CLV <input type="checkbox"/> AOLV <input type="checkbox"/> OLV/PM <input type="checkbox"/> AOLV/PM <input type="checkbox"/> CLV/PM <input type="checkbox"/> EZOLV</p> <p>Sets the current level that decreases the output current during Current Detection Speed Search.</p>   | 1.50 (1.50 - 3.50)                   | 228  |
| b3-32 (0BC1) Expert | Spd Search Current Complete Lvl  | <p><input type="checkbox"/> V/f <input type="checkbox"/> CL-V/f <input type="checkbox"/> OLV <input type="checkbox"/> CLV <input type="checkbox"/> AOLV <input type="checkbox"/> OLV/PM <input type="checkbox"/> AOLV/PM <input type="checkbox"/> CLV/PM <input type="checkbox"/> EZOLV</p> <p>Sets the current level that completes Speed Search.</p>   | 1.20 (0.00 - 1.49)                   | 228  |

## 1.5 b: Application

| No. (Hex.)          | Name                                     | Description  | Default (Range)                      | Ref. |
|---------------------|--|--|--------------------------------------|------|
| b3-33 (0B3F) Expert | Speed Search during Uv Selection         | <b>V/f</b> <b>CL-V/f</b> <b>OLV</b> <b>CLV</b> <b>AOLV</b> <b>OLV/PM</b> <b>AOLV/PM</b> <b>CLV/PM</b> <b>EZOLV</b><br>Sets the function that starts Speed Search at start-up if the drive detects a Uv [Undervoltage] when it receives a Run command.<br>0 : Disabled<br>1 : Enabled   | 1<br>(0, 1)                          | 229  |
| b3-35 (0BC3) Expert | Low Back EMF Detection Level             | <b>V/f</b> <b>CL-V/f</b> <b>OLV</b> <b>CLV</b> <b>AOLV</b> <b>OLV/PM</b> <b>AOLV/PM</b> <b>CLV/PM</b> <b>EZOLV</b><br>Sets the Low Back EMF Detection Level. Usually it is not necessary to change this setting.   | 10%<br>(5 - 50%)                     | 229  |
| b3-36 (0BC4) Expert | High Back EMF Detection Level            | <b>V/f</b> <b>CL-V/f</b> <b>OLV</b> <b>CLV</b> <b>AOLV</b> <b>OLV/PM</b> <b>AOLV/PM</b> <b>CLV/PM</b> <b>EZOLV</b><br>Sets the voltage level for Speed Search restart. Usually it is not necessary to change this setting.   | 0.970<br>(0.500 - 1.000)             | 229  |
| b3-54 (3123)        | Search Time                              | <b>V/f</b> <b>CL-V/f</b> <b>OLV</b> <b>CLV</b> <b>AOLV</b> <b>OLV/PM</b> <b>AOLV/PM</b> <b>CLV/PM</b> <b>EZOLV</b><br>Sets the length of time that the drive will run Speed Search.  | 400 ms<br>(10 - 2000 ms)             | 229  |
| b3-55 (3124) Expert | Current Increment Time                   | <b>V/f</b> <b>CL-V/f</b> <b>OLV</b> <b>CLV</b> <b>AOLV</b> <b>OLV/PM</b> <b>AOLV/PM</b> <b>CLV/PM</b> <b>EZOLV</b><br>Sets the length of time that the drive will increase the current from zero current to the setting value of b3-06 [Speed Estimation Current Level 1].   | 10 ms<br>(10 - 2000 ms)              | 230  |
| b3-56 (3126)        | InverseRotationSearch WaitTime           | <b>V/f</b> <b>CL-V/f</b> <b>OLV</b> <b>CLV</b> <b>AOLV</b> <b>OLV/PM</b> <b>AOLV/PM</b> <b>CLV/PM</b> <b>EZOLV</b><br>Sets the wait time until inverse rotation search starts after the completion of forward search if inverse rotation search is performed during Current Detection Speed Search.  | Determined by o2-04<br>(0.1 - 5.0 s) | 230  |
| b3-61 (1B96) Expert | Response Gain for Initial Pole Detection | <b>V/f</b> <b>CL-V/f</b> <b>OLV</b> <b>CLV</b> <b>AOLV</b> <b>OLV/PM</b> <b>AOLV/PM</b> <b>CLV/PM</b> <b>EZOLV</b><br>Adjusts the Initial Pole Detection response gain when A1-02 = 6 [Control Method Selection = AOLV/PM]. Set b3-61 > 0.0 for an ordinary IPM motor.<br>The drive sets this value automatically when High Frequency Injection Tuning completes correctly.<br><b>Note:</b><br>• It is available when n8-35 = 1 [Initial Pole Detection Method = High Frequency Injection].<br>• To adjust the Initial Pole Detection response gain when A1-02 = 5, 7 [OLV/PM, CLV/PM], set n8-41 [Response Gain for High Frequency Injection Speed Estimation]. | 5.0<br>(-20.0 - +20.0)               | 230  |

## ◆ b4: Timer Function

| No. (Hex.)          | Name                          | Description  | Default (Range)           | Ref. |
|---------------------|-------------------------------|--|---------------------------|------|
| b4-01 (01A3)        | Timer Function ON-Delay Time  | <b>V/f</b> <b>CL-V/f</b> <b>OLV</b> <b>CLV</b> <b>AOLV</b> <b>OLV/PM</b> <b>AOLV/PM</b> <b>CLV/PM</b> <b>EZOLV</b><br>Sets the ON-delay time for the timer input.  | 0.0 s<br>(0.0 - 3000.0 s) | 231  |
| b4-02 (01A4)        | Timer Function OFF-Delay Time | <b>V/f</b> <b>CL-V/f</b> <b>OLV</b> <b>CLV</b> <b>AOLV</b> <b>OLV/PM</b> <b>AOLV/PM</b> <b>CLV/PM</b> <b>EZOLV</b><br>Sets the OFF-delay time for the timer input.   | 0.0 s<br>(0.0 - 3000.0 s) | 231  |
| b4-03 (0B30) Expert | H2-01 ON Delay Time           | <b>V/f</b> <b>CL-V/f</b> <b>OLV</b> <b>CLV</b> <b>AOLV</b> <b>OLV/PM</b> <b>AOLV/PM</b> <b>CLV/PM</b> <b>EZOLV</b><br>Sets the delay time until the contact is turned ON after the function set with H2-01 turns ON. | 0 ms<br>(0 - 65000 ms)    | 231  |
| b4-04 (0B31) Expert | Terminal H2-01 OFF-Delay Time | <b>V/f</b> <b>CL-V/f</b> <b>OLV</b> <b>CLV</b> <b>AOLV</b> <b>OLV/PM</b> <b>AOLV/PM</b> <b>CLV/PM</b> <b>EZOLV</b><br>Sets the delay time to deactivate the contact after the function set in H2-01 deactivates.     | 0 ms<br>(0 - 65000 ms)    | 231  |
| b4-05 (0B32) Expert | Terminal H2-02 ON-Delay Time  | <b>V/f</b> <b>CL-V/f</b> <b>OLV</b> <b>CLV</b> <b>AOLV</b> <b>OLV/PM</b> <b>AOLV/PM</b> <b>CLV/PM</b> <b>EZOLV</b><br>Sets the delay time to activate the contact after the function set in H2-02 activates.         | 0 ms<br>(0 - 65000 ms)    | 231  |
| b4-06 (0B33) Expert | Terminal H2-02 OFF-Delay Time | <b>V/f</b> <b>CL-V/f</b> <b>OLV</b> <b>CLV</b> <b>AOLV</b> <b>OLV/PM</b> <b>AOLV/PM</b> <b>CLV/PM</b> <b>EZOLV</b><br>Sets the delay time to deactivate the contact after the function set in H2-02 deactivates.     | 0 ms<br>(0 - 65000 ms)    | 231  |
| b4-07 (0B34) Expert | Terminal M5-M6 ON-Delay Time  | <b>V/f</b> <b>CL-V/f</b> <b>OLV</b> <b>CLV</b> <b>AOLV</b> <b>OLV/PM</b> <b>AOLV/PM</b> <b>CLV/PM</b> <b>EZOLV</b><br>Sets the delay time to activate the contact after the function set in H2-03 activates.         | 0 ms<br>(0 - 65000 ms)    | 232  |
| b4-08 (0B35) Expert | Terminal M5-M6 OFF-Delay Time | <b>V/f</b> <b>CL-V/f</b> <b>OLV</b> <b>CLV</b> <b>AOLV</b> <b>OLV/PM</b> <b>AOLV/PM</b> <b>CLV/PM</b> <b>EZOLV</b><br>Sets the delay time to deactivate the contact after the function set in H2-03 deactivates.     | 0 ms<br>(0 - 65000 ms)    | 232  |

## ◆ b5: PID Control

| No. (Hex.)                       | Name                            | Description   | Default (Range)            | Ref. |
|----------------------------------|---------------------------------|---|----------------------------|------|
| b5-01<br>(01A5)                  | PID Mode Setting                | <p>V/f CL-V/f OLV CLV AOLV OLV/PM AOLV/PM CLV/PM EZOLV</p> <p>Sets the type of PID control.<br/>           0 : PID control disabled<br/>           1 : Output Frequency = PID Output 1<br/>           2 : Output Frequency = PID Output 2<br/>           3 : Output Frequency = Frequency Reference + PID Output 1<br/>           4 : Output Frequency = Frequency Reference + PID Output 2<br/>           5 : Setting 1 Compatibility Mode with conventional products<br/>           6 : Setting 2 Compatibility Mode with conventional products<br/>           7 : Setting 3 Compatibility Mode with conventional products<br/>           8 : Setting 4 Compatibility Mode with conventional products</p> <p><b>Note:</b><br/>           Use settings 5 to 8 when the drive is a replacement for a previous generation drive.</p> | 0<br>(0 - 8)               | 237  |
| b5-02<br>(01A6)<br>RUN           | Proportional Gain (P)           | <p>V/f CL-V/f OLV CLV AOLV OLV/PM AOLV/PM CLV/PM EZOLV</p> <p>Sets the proportional gain (P) that is applied to PID input.</p>  | 1.00<br>(0.00 - 25.00)     | 238  |
| b5-03<br>(01A7)<br>RUN           | Integral Time (I)               | <p>V/f CL-V/f OLV CLV AOLV OLV/PM AOLV/PM CLV/PM EZOLV</p> <p>Sets the integral time (I) that is applied to PID input.</p>  | 1.0 s<br>(0.0 - 360.0 s)   | 238  |
| b5-04<br>(01A8)<br>RUN           | Integral Limit                  | <p>V/f CL-V/f OLV CLV AOLV OLV/PM AOLV/PM CLV/PM EZOLV</p> <p>Sets the upper limit for integral control (I) as a percentage of the Maximum Output Frequency.</p> <p><b>Note:</b><br/>           Parameter A1-02 [Control Method Selection] selects which parameter is the maximum output frequency.<br/>           • A1-02 ≠ 8 [EZOLV]: E1-04 [Maximum Output Frequency]<br/>           • A1-02 = 8: E9-02 [Maximum Speed]</p>  | 100.0%<br>(0.0 - 100.0%)   | 238  |
| b5-05<br>(01A9)<br>RUN           | Derivative Time (D)             | <p>V/f CL-V/f OLV CLV AOLV OLV/PM AOLV/PM CLV/PM EZOLV</p> <p>Sets the derivative time (D) for PID control. This parameter adjusts system responsiveness.</p>   | 0.00 s<br>(0.00 - 10.00 s) | 239  |
| b5-06<br>(01AA)<br>RUN           | PID Output Limit                | <p>V/f CL-V/f OLV CLV AOLV OLV/PM AOLV/PM CLV/PM EZOLV</p> <p>Sets the maximum possible output from the PID controller as a percentage of the Maximum Output Frequency.</p> <p><b>Note:</b><br/>           Parameter A1-02 [Control Method Selection] selects which parameter is the maximum output frequency.<br/>           • A1-02 ≠ 8 [EZOLV]: E1-04 [Maximum Output Frequency]<br/>           • A1-02 = 8: E9-02 [Maximum Speed]</p>   | 100.0%<br>(0.0 - 100.0%)   | 239  |
| b5-07<br>(01AB)<br>RUN           | PID Offset Adjustment           | <p>V/f CL-V/f OLV CLV AOLV OLV/PM AOLV/PM CLV/PM EZOLV</p> <p>Sets the offset for the PID control output as a percentage of the Maximum Output Frequency.</p> <p><b>Note:</b><br/>           Parameter A1-02 [Control Method Selection] selects which parameter is the maximum output frequency.<br/>           • A1-02 ≠ 8 [EZOLV]: E1-04 [Maximum Output Frequency]<br/>           • A1-02 = 8: E9-02 [Maximum Speed]</p>   | 0.0%<br>(-100.0 - +100.0%) | 239  |
| b5-08<br>(01AC)<br>RUN<br>Expert | PID Primary Delay Time Constant | <p>V/f CL-V/f OLV CLV AOLV OLV/PM AOLV/PM CLV/PM EZOLV</p> <p>Sets the primary delay time constant for the PID control output. Usually it is not necessary to change this setting.</p>  | 0.00 s<br>(0.00 - 10.00 s) | 239  |
| b5-09<br>(01AD)                  | PID Output Level Selection      | <p>V/f CL-V/f OLV CLV AOLV OLV/PM AOLV/PM CLV/PM EZOLV</p> <p>Sets the polarity of the PID output.<br/>           0 : Normal Output (Direct Acting)<br/>           1 : Reverse Output (Reverse Acting)</p>  | 0<br>(0, 1)                | 239  |
| b5-10<br>(01AE)<br>RUN           | PID Output Gain Setting         | <p>V/f CL-V/f OLV CLV AOLV OLV/PM AOLV/PM CLV/PM EZOLV</p> <p>Sets the amount of gain to apply to the PID output.</p>   | 1.00<br>(0.00 - 25.00)     | 239  |

## 1.5 b: Application

| No. (Hex.)             | Name                             | Description  | Default (Range)                      | Ref. |
|------------------------|----------------------------------|--|--------------------------------------|------|
| b5-11<br>(01AF)        | PID Output Reverse Selection     | <p><b>V/f</b> <b>CL-V/f</b> <b>OLV</b> <b>CLV</b> <b>AOLV</b> <b>OLV/PM</b> <b>AOLV/PM</b> <b>CLV/PM</b> <b>EZOLV</b></p> <p>Sets the function that enables and disables reverse motor rotation for negative PID control output.</p> <p>0 : Lower Limit is Zero<br/>1 : Negative Output Accepted</p>   | 0<br>(0, 1)                          | 240  |
| b5-12<br>(01B0)        | Feedback Loss Detection Select   | <p><b>V/f</b> <b>CL-V/f</b> <b>OLV</b> <b>CLV</b> <b>AOLV</b> <b>OLV/PM</b> <b>AOLV/PM</b> <b>CLV/PM</b> <b>EZOLV</b></p> <p>Sets the drive response to PID Feedback Low/High. Sets drive operation after the drive detects PID feedback Low/High.</p> <p>0 : Digital Out Only, Always Detect<br/>1 : Alarm + Digital Out, Always Det<br/>2 : Fault + Digital Out, Always Det<br/>3 : Digital Out Only, @ PID Enable<br/>4 : Alarm + Digital Out, @PID Enable<br/>5 : Fault + Digital Out, @PID Enable</p> | 0<br>(0 - 5)                         | 240  |
| b5-13<br>(01B1)        | PID Feedback Loss Detection Lvl  | <p><b>V/f</b> <b>CL-V/f</b> <b>OLV</b> <b>CLV</b> <b>AOLV</b> <b>OLV/PM</b> <b>AOLV/PM</b> <b>CLV/PM</b> <b>EZOLV</b></p> <p>Sets the level that triggers <i>PID Feedback Loss [FbL]</i> detection as a percentage of the Maximum Output Frequency.</p> <p><b>Note:</b><br/>Parameter <i>A1-02 [Control Method Selection]</i> selects which parameter is the maximum output frequency.<br/>• <i>A1-02 ≠ 8 [EZOLV]: E1-04 [Maximum Output Frequency]</i><br/>• <i>A1-02 = 8: E9-02 [Maximum Speed]</i></p>  | 0%<br>(0 - 100%)                     | 241  |
| b5-14<br>(01B2)        | PID Feedback Loss Detection Time | <p><b>V/f</b> <b>CL-V/f</b> <b>OLV</b> <b>CLV</b> <b>AOLV</b> <b>OLV/PM</b> <b>AOLV/PM</b> <b>CLV/PM</b> <b>EZOLV</b></p> <p>Sets the length of time that PID Feedback must be less than <i>b5-13 [PID Feedback Loss Detection Lvl]</i> to detect <i>PID Feedback Loss [FbL]</i>.</p>  | 1.0 s<br>(0.0 - 25.5 s)              | 241  |
| b5-15<br>(01B3)        | PID Sleep Function Start Level   | <p><b>V/f</b> <b>CL-V/f</b> <b>OLV</b> <b>CLV</b> <b>AOLV</b> <b>OLV/PM</b> <b>AOLV/PM</b> <b>CLV/PM</b> <b>EZOLV</b></p> <p>Sets the output level that triggers the PID Sleep function.</p>   | Determined by A1-02<br>(0.0 - 590.0) | 241  |
| b5-16<br>(01B4)        | PID Sleep Delay Time             | <p><b>V/f</b> <b>CL-V/f</b> <b>OLV</b> <b>CLV</b> <b>AOLV</b> <b>OLV/PM</b> <b>AOLV/PM</b> <b>CLV/PM</b> <b>EZOLV</b></p> <p>Sets a delay time to start or stop the PID Sleep function.</p>  | 0.0 s<br>(0.0 - 25.5 s)              | 241  |
| b5-17<br>(01B5)<br>RUN | PID Accel/Decel Time             | <p><b>V/f</b> <b>CL-V/f</b> <b>OLV</b> <b>CLV</b> <b>AOLV</b> <b>OLV/PM</b> <b>AOLV/PM</b> <b>CLV/PM</b> <b>EZOLV</b></p> <p>Raises or lowers the PID setpoint using the acceleration and deceleration times set to the drive. This is a soft-starter for the PID setpoint.</p>  | 0.0 s<br>(0.0 - 6000.0 s)            | 241  |
| b5-18<br>(01DC)        | PID Setpoint Selection           | <p><b>V/f</b> <b>CL-V/f</b> <b>OLV</b> <b>CLV</b> <b>AOLV</b> <b>OLV/PM</b> <b>AOLV/PM</b> <b>CLV/PM</b> <b>EZOLV</b></p> <p>Sets the function that enables and disables <i>b5-19 [PID Setpoint Value]</i>.</p> <p>0 : PID Setpoint Disabled<br/>1 : PID Setpoint Enabled</p>  | 0<br>(0, 1)                          | 242  |
| b5-19<br>(01DD)<br>RUN | PID Setpoint                     | <p><b>V/f</b> <b>CL-V/f</b> <b>OLV</b> <b>CLV</b> <b>AOLV</b> <b>OLV/PM</b> <b>AOLV/PM</b> <b>CLV/PM</b> <b>EZOLV</b></p> <p>Sets the PID setpoint when <i>b5-18 = 1 [PID Setpoint Selection = Enabled]</i>.</p>   | 0.00%<br>(0.00 - 100.00%)            | 242  |
| b5-20<br>(01E2)        | PID Unit Selection               | <p><b>V/f</b> <b>CL-V/f</b> <b>OLV</b> <b>CLV</b> <b>AOLV</b> <b>OLV/PM</b> <b>AOLV/PM</b> <b>CLV/PM</b> <b>EZOLV</b></p> <p>Sets the number of digits to set and show the PID setpoint.</p> <p>0 : 0.01Hz units<br/>1 : 0.01% units<br/>2 : rev/min<br/>3 : User Units</p>  | 1<br>(0 - 3)                         | 242  |
| b5-34<br>(019F)<br>RUN | PID Output Lower Limit Level     | <p><b>V/f</b> <b>CL-V/f</b> <b>OLV</b> <b>CLV</b> <b>AOLV</b> <b>OLV/PM</b> <b>AOLV/PM</b> <b>CLV/PM</b> <b>EZOLV</b></p> <p>Sets the output lower limit for the PID control as a percentage of the Maximum Output Frequency.</p> <p><b>Note:</b><br/>Parameter <i>A1-02 [Control Method Selection]</i> selects which parameter is the maximum output frequency.<br/>• <i>A1-02 ≠ 8 [EZOLV]: E1-04 [Maximum Output Frequency]</i><br/>• <i>A1-02 = 8: E9-02 [Maximum Speed]</i></p>                        | 0.0%<br>(-100.0 - +100.0%)           | 242  |
| b5-35<br>(01A0)<br>RUN | PID Input Limit Level            | <p><b>V/f</b> <b>CL-V/f</b> <b>OLV</b> <b>CLV</b> <b>AOLV</b> <b>OLV/PM</b> <b>AOLV/PM</b> <b>CLV/PM</b> <b>EZOLV</b></p> <p>Sets the output upper limit for the PID control as a percentage of the Maximum Output Frequency.</p> <p><b>Note:</b><br/>Parameter <i>A1-02 [Control Method Selection]</i> selects which parameter is the maximum output frequency.<br/>• <i>A1-02 ≠ 8 [EZOLV]: E1-04 [Maximum Output Frequency]</i><br/>• <i>A1-02 = 8: E9-02 [Maximum Speed]</i></p>                        | 1000.0%<br>(0.0 - 1000.0%)           | 243  |



| No. (Hex.)                        | Name                             | Description   | Default (Range)                    | Ref. |
|-----------------------------------|----------------------------------|---|------------------------------------|------|
| b5-36 (01A1)                      | PID High Feedback Detection Lvl  | <b>V/f</b> <b>CL-V/f</b> <b>OLV</b> <b>CLV</b> <b>AOLV</b> <b>OLV/PM</b> <b>AOLV/PM</b> <b>CLV/PM</b> <b>EZOLV</b><br>Sets the level that triggers <i>Excessive PID Feedback [FbH]</i> as a percentage of the Maximum Output Frequency.<br><b>Note:</b><br>Parameter <i>A1-02 [Control Method Selection]</i> selects which parameter is the maximum output frequency.<br>• <i>A1-02 ≠ 8 [EZOLV]: E1-04 [Maximum Output Frequency]</i><br>• <i>A1-02 = 8: E9-02 [Maximum Speed]</i>  | 100%<br>(0 - 100%)                 | 243  |
| b5-37 (01A2)                      | PID High Feedback Detection Time | <b>V/f</b> <b>CL-V/f</b> <b>OLV</b> <b>CLV</b> <b>AOLV</b> <b>OLV/PM</b> <b>AOLV/PM</b> <b>CLV/PM</b> <b>EZOLV</b><br>Sets the length of time that the PID feedback signal must be more than the level set in <i>b5-36 [PID Feedback High Detection Lvl]</i> to cause <i>Excessive PID Feedback [FbH]</i> .   | 1.0 s<br>(0.0 - 25.5 s)            | 243  |
| b5-38 (01FE)                      | PID User Unit Display Scaling    | <b>V/f</b> <b>CL-V/f</b> <b>OLV</b> <b>CLV</b> <b>AOLV</b> <b>OLV/PM</b> <b>AOLV/PM</b> <b>CLV/PM</b> <b>EZOLV</b><br>Sets the value that the drive sets or shows as the PID setpoint when at the maximum output frequency.   | Determined by b5-20<br>(1 - 60000) | 243  |
| b5-39 (01FF)                      | PID User Unit Display Digits     | <b>V/f</b> <b>CL-V/f</b> <b>OLV</b> <b>CLV</b> <b>AOLV</b> <b>OLV/PM</b> <b>AOLV/PM</b> <b>CLV/PM</b> <b>EZOLV</b><br>Sets the number of digits to set and show the PID setpoint.<br>0 : No Decimal Places (XXXXX)<br>1 : One Decimal Places (XXXX.X)<br>2 : Two Decimal Places (XXX.XX)<br>3 : Three Decimal Places (XX.XXX)   | Determined by b5-20<br>(0 - 3)     | 243  |
| b5-40 (017F)                      | Frequency Reference Monitor @PID | <b>V/f</b> <b>CL-V/f</b> <b>OLV</b> <b>CLV</b> <b>AOLV</b> <b>OLV/PM</b> <b>AOLV/PM</b> <b>CLV/PM</b> <b>EZOLV</b><br>Sets the contents for monitor <i>U1-01 [Frequency Reference]</i> in PID control.<br>0 : U1-01 Includes PID Output<br>1 : U1-01 Excludes PID Output  | 0<br>(0, 1)                        | 244  |
| b5-47 (017D)                      | PID Trim Mode Output Reverse Sel | <b>V/f</b> <b>CL-V/f</b> <b>OLV</b> <b>CLV</b> <b>AOLV</b> <b>OLV/PM</b> <b>AOLV/PM</b> <b>CLV/PM</b> <b>EZOLV</b><br>Sets whether or not the motor should rotate in reverse when the PID control output is negative.<br>0 : Lower Limit is Zero<br>1 : Negative Output Accepted  | 1<br>(0, 1)                        | 244  |
| b5-53 (0B8F) RUN                  | PID Integrator Ramp Limit        | <b>V/f</b> <b>CL-V/f</b> <b>OLV</b> <b>CLV</b> <b>AOLV</b> <b>OLV/PM</b> <b>AOLV/PM</b> <b>CLV/PM</b> <b>EZOLV</b><br>Sets the responsiveness of PID control when the PID feedback changes quickly.   | 0.0 Hz<br>(0.0 - 10.0 Hz)          | 244  |
| b5-55 (0BE1)                      | PID Feedback Monitor Selection   | <b>V/f</b> <b>CL-V/f</b> <b>OLV</b> <b>CLV</b> <b>AOLV</b> <b>OLV/PM</b> <b>AOLV/PM</b> <b>CLV/PM</b> <b>EZOLV</b><br>Selects the monitor ( <i>Ux-xx</i> ) used as the PID Feedback. Set the <i>x-xx</i> part of the <i>Ux-xx [Monitor]</i> .   | 000<br>(000 - 999)                 | 244  |
| b5-56 (0BE2)                      | PID Feedback Monitor Gain        | <b>V/f</b> <b>CL-V/f</b> <b>OLV</b> <b>CLV</b> <b>AOLV</b> <b>OLV/PM</b> <b>AOLV/PM</b> <b>CLV/PM</b> <b>EZOLV</b><br>Sets the gain for the monitor specified in <i>b5-55 [PID Feedback Monitor Selection]</i> .  | 1.00<br>(0.00 - 10.00)             | 245  |
| b5-57 (11DD)                      | PID Feedback Monitor Bias        | <b>V/f</b> <b>CL-V/f</b> <b>OLV</b> <b>CLV</b> <b>AOLV</b> <b>OLV/PM</b> <b>AOLV/PM</b> <b>CLV/PM</b> <b>EZOLV</b><br>Sets the bias for the monitor specified in <i>b5-55 [PID Feedback Monitor Selection]</i> .  | 0.00<br>(-10.00 - +10.00)          | 245  |
| b5-58 to b5-60: (1182 - 1184) RUN | PID Setpoints 2 to 4             | <b>V/f</b> <b>CL-V/f</b> <b>OLV</b> <b>CLV</b> <b>AOLV</b> <b>OLV/PM</b> <b>AOLV/PM</b> <b>CLV/PM</b> <b>EZOLV</b><br>Sets the PID setpoint when <i>H1-xx = 3E or 3F [MFDI Function Select = PID Setpoint Selection 1/2]</i> . This value is a percentage of the maximum output frequency.<br><b>Note:</b><br>Parameter <i>A1-02 [Control Method Selection]</i> selects which parameter is the maximum output frequency.<br>• <i>A1-02 ≠ 8 [EZOLV]: E1-04 [Maximum Output Frequency]</i><br>• <i>A1-02 = 8: E9-02 [Maximum Speed]</i> | 0.00%<br>(0.00 - 100.00%)          | 245  |
| b5-61 (119A)                      | PID Trim Mode Lower Limit Sel    | <b>V/f</b> <b>CL-V/f</b> <b>OLV</b> <b>CLV</b> <b>AOLV</b> <b>OLV/PM</b> <b>AOLV/PM</b> <b>CLV/PM</b> <b>EZOLV</b><br>Sets the function that adjusts the PID output in relation to the frequency reference.<br>0 : No<br>1 : Yes  | 0<br>(0, 1)                        | 245  |
| b5-62 (119B)                      | PID Trim Mode Lower Limit Value  | <b>V/f</b> <b>CL-V/f</b> <b>OLV</b> <b>CLV</b> <b>AOLV</b> <b>OLV/PM</b> <b>AOLV/PM</b> <b>CLV/PM</b> <b>EZOLV</b><br>Sets the PID Trim Mode Lower Limit Value as a percentage of the maximum output frequency.<br><b>Note:</b><br>Parameter <i>A1-02 [Control Method Selection]</i> selects which parameter is the maximum output frequency.<br>• <i>A1-02 ≠ 8 [EZOLV]: E1-04 [Maximum Output Frequency]</i><br>• <i>A1-02 = 8: E9-02 [Maximum Speed]</i>  | 0.00%<br>(0.00 - 100.00%)          | 245  |
| b5-63 (119C)                      | PID Differential FB Monitor Sel  | <b>V/f</b> <b>CL-V/f</b> <b>OLV</b> <b>CLV</b> <b>AOLV</b> <b>OLV/PM</b> <b>AOLV/PM</b> <b>CLV/PM</b> <b>EZOLV</b><br>Selects the monitor ( <i>Ux-xx</i> ) used as the PID Differential Feedback. Set the <i>x-xx</i> part of the <i>Ux-xx [Monitor]</i> .  | 000<br>(000 - 999)                 | 246  |

## 1.5 b: Application

| No. (Hex.)       | Name                             | Description   | Default (Range)  | Ref. |
|------------------|----------------------------------|---|--|------|
| b5-64 (119D)     | PID Differential FB Monitor Gain | <b>V/f</b> <b>CL-V/f</b> <b>OLV</b> <b>CLV</b> <b>AOLV</b> <b>OLV/PM</b> <b>AOLV/PM</b> <b>CLV/PM</b> <b>EZOLV</b><br>Sets the gain for the monitor specified in b5-63 [PID Differential FB Monitor Sel].   | 1.00<br>(0.00 - 10.00)   | 246  |
| b5-65 (119F)     | PID Differential FB Monitor Bias | <b>V/f</b> <b>CL-V/f</b> <b>OLV</b> <b>CLV</b> <b>AOLV</b> <b>OLV/PM</b> <b>AOLV/PM</b> <b>CLV/PM</b> <b>EZOLV</b><br>Sets the bias for the monitor specified in b5-63 [PID Differential FB Monitor Sel].   | 0.00<br>(-10.00 - +10.00)  | 246  |
| b5-66 (11DE)     | PID Feedback Monitor Level       | <b>V/f</b> <b>CL-V/f</b> <b>OLV</b> <b>CLV</b> <b>AOLV</b> <b>OLV/PM</b> <b>AOLV/PM</b> <b>CLV/PM</b> <b>EZOLV</b><br>Sets the signal level for the monitor specified in b5-55 [PID Feedback Monitor Selection].<br>0 : Absolute<br>1 : Bi-directional (+/-)  | 0<br>(0, 1)  | 246  |
| b5-67 (11DF)     | PID Differential FB Monitor Lvl  | <b>V/f</b> <b>CL-V/f</b> <b>OLV</b> <b>CLV</b> <b>AOLV</b> <b>OLV/PM</b> <b>AOLV/PM</b> <b>CLV/PM</b> <b>EZOLV</b><br>Sets the signal level for the monitor specified in b5-63 [PID Differential FB Monitor Sel].<br>0 : Absolute<br>1 : Bi-directional (+/-)   | 0<br>(0, 1)  | 246  |
| b5-89 (0B89) RUN | Sleep Method Selection           | <b>V/f</b> <b>CL-V/f</b> <b>OLV</b> <b>CLV</b> <b>AOLV</b> <b>OLV/PM</b> <b>AOLV/PM</b> <b>CLV/PM</b> <b>EZOLV</b><br>Sets sleep and wake up operation when using PID.<br>0 : Standard<br>1 : EZ Sleep/Wake-up  | 0<br>(0, 1)  | 246  |
| b5-90 (0B90)     | EZ Sleep Unit                    | <b>V/f</b> <b>CL-V/f</b> <b>OLV</b> <b>CLV</b> <b>AOLV</b> <b>OLV/PM</b> <b>AOLV/PM</b> <b>CLV/PM</b> <b>EZOLV</b><br>Sets the measurement units for b5-91 [EZ Sleep Minimum Speed] and b5-92 [EZ Sleep Level].<br>0 : Hz<br>1 : rev/min  | 0<br>(0, 1)  | 247  |
| b5-91 (0B91) RUN | EZ Sleep Minimum Speed           | <b>V/f</b> <b>CL-V/f</b> <b>OLV</b> <b>CLV</b> <b>AOLV</b> <b>OLV/PM</b> <b>AOLV/PM</b> <b>CLV/PM</b> <b>EZOLV</b><br>Sets the minimum speed for the EZ Sleep/Wakeup function. This parameter uses the largest value from b5-91, b5-34 [PID Output Lower Limit Level], and d2-02 [Frequency Reference Lower Limit]. | 0.0 Hz or 0 min <sup>-1</sup> (r/min)<br>(0.0 to 590.0 Hz or 0 to 35400 min <sup>-1</sup> (r/min)) | 247  |
| b5-92 (0B92) RUN | EZ Sleep Level                   | <b>V/f</b> <b>CL-V/f</b> <b>OLV</b> <b>CLV</b> <b>AOLV</b> <b>OLV/PM</b> <b>AOLV/PM</b> <b>CLV/PM</b> <b>EZOLV</b><br>Sets the value that the output frequency or motor speed must be less than b5-93 [EZ Sleep Time] to enter Sleep Mode.  | 0.0 Hz or 0 min <sup>-1</sup> (r/min)<br>(0.0 to 590.0 Hz or 0 to 35400 min <sup>-1</sup> (r/min)) | 247  |
| b5-93 (0B93) RUN | EZ Sleep Time                    | <b>V/f</b> <b>CL-V/f</b> <b>OLV</b> <b>CLV</b> <b>AOLV</b> <b>OLV/PM</b> <b>AOLV/PM</b> <b>CLV/PM</b> <b>EZOLV</b><br>Sets the length of time that the output frequency or motor speed must be less than b5-92 [EZ Sleep Level] to enter Sleep Mode.  | 5.0 s<br>(0.0 - 1000.0 s)  | 247  |
| b5-94 (0B94) RUN | EZ Sleep Wake-up Level           | <b>V/f</b> <b>CL-V/f</b> <b>OLV</b> <b>CLV</b> <b>AOLV</b> <b>OLV/PM</b> <b>AOLV/PM</b> <b>CLV/PM</b> <b>EZOLV</b><br>Sets the level at which the drive resumes operation when exiting Sleep Mode.  | 0.00%<br>(0.00 - 600.00%)  | 247  |
| b5-95 (0B95)     | EZ Sleep Wake-up Mode            | <b>V/f</b> <b>CL-V/f</b> <b>OLV</b> <b>CLV</b> <b>AOLV</b> <b>OLV/PM</b> <b>AOLV/PM</b> <b>CLV/PM</b> <b>EZOLV</b><br>Sets the wake-up mode to use when exiting Sleep Mode.<br>0 : Absolute<br>1 : Setpoint Delta   | 0<br>(0, 1)  | 248  |
| b5-96 (0B96) RUN | EZ Sleep Wake-up Time            | <b>V/f</b> <b>CL-V/f</b> <b>OLV</b> <b>CLV</b> <b>AOLV</b> <b>OLV/PM</b> <b>AOLV/PM</b> <b>CLV/PM</b> <b>EZOLV</b><br>Sets the EZ Wake-up time.   | 1.0 s<br>(0.0 - 1000.0 s)  | 248  |

## ◆ b6: Dwell Function

| No. (Hex.)   | Name                     | Description  | Default (Range)              | Ref. |
|--------------|--------------------------|--|------------------------------|------|
| b6-01 (01B6) | Dwell Reference at Start | <b>V/f</b> <b>CL-V/f</b> <b>OLV</b> <b>CLV</b> <b>AOLV</b> <b>OLV/PM</b> <b>AOLV/PM</b> <b>CLV/PM</b> <b>EZOLV</b><br>Sets the output frequency that the drive will hold momentarily when the motor starts.              | 0.0<br>(Determined by A1-02) | 248  |
| b6-02 (01B7) | Dwell Time at Start      | <b>V/f</b> <b>CL-V/f</b> <b>OLV</b> <b>CLV</b> <b>AOLV</b> <b>OLV/PM</b> <b>AOLV/PM</b> <b>CLV/PM</b> <b>EZOLV</b><br>Sets the length of time that the drive will hold the output frequency when the motor starts.       | 0.0 s<br>(0.0 - 10.0 s)      | 249  |
| b6-03 (01B8) | Dwell Reference at Stop  | <b>V/f</b> <b>CL-V/f</b> <b>OLV</b> <b>CLV</b> <b>AOLV</b> <b>OLV/PM</b> <b>AOLV/PM</b> <b>CLV/PM</b> <b>EZOLV</b><br>Sets the output frequency that the drive will hold momentarily when ramping to stop the motor.     | 0.0<br>(Determined by A1-02) | 249  |
| b6-04 (01B9) | Dwell Time at Stop       | <b>V/f</b> <b>CL-V/f</b> <b>OLV</b> <b>CLV</b> <b>AOLV</b> <b>OLV/PM</b> <b>AOLV/PM</b> <b>CLV/PM</b> <b>EZOLV</b><br>Sets the length of time for the drive to hold the output frequency when ramping to stop the motor. | 0.0 s<br>(0.0 - 10.0 s)      | 249  |

## ◆ b7: Droop Control

| No. (Hex.)             | Name                          | Description  | Default (Range)           | Ref. |
|------------------------|-------------------------------|--|---------------------------|------|
| b7-01<br>(01CA)<br>RUN | Droop Control Gain            | <input type="checkbox"/> V/f <input type="checkbox"/> CL-V/f <input type="checkbox"/> OLV <input checked="" type="checkbox"/> CLV <input type="checkbox"/> AOLV <input type="checkbox"/> OLV/PM <input type="checkbox"/> AOLV/PM <input type="checkbox"/> CLV/PM <input type="checkbox"/> EZOLV<br>Sets the amount of deceleration when the torque reference is at 100% as a percentage of <i>E1-04 [Maximum Output Frequency]</i> .                     | 0.0%<br>(0.0 - 100.0%)    | 250  |
| b7-02<br>(01CB)<br>RUN | Droop Control Delay Time      | <input type="checkbox"/> V/f <input type="checkbox"/> CL-V/f <input type="checkbox"/> OLV <input checked="" type="checkbox"/> CLV <input type="checkbox"/> AOLV <input type="checkbox"/> OLV/PM <input type="checkbox"/> AOLV/PM <input type="checkbox"/> CLV/PM <input type="checkbox"/> EZOLV<br>Sets the responsiveness of Droop control. Decrease this setting when drive response is slow. Increase this setting when hunting or oscillation occur. | 0.05 s<br>(0.03 - 2.00 s) | 250  |
| b7-03<br>(017E)        | Droop Control Limit Selection | <input type="checkbox"/> V/f <input type="checkbox"/> CL-V/f <input type="checkbox"/> OLV <input checked="" type="checkbox"/> CLV <input type="checkbox"/> AOLV <input type="checkbox"/> OLV/PM <input type="checkbox"/> AOLV/PM <input type="checkbox"/> CLV/PM <input type="checkbox"/> EZOLV<br>Sets the Droop control limit function.<br>0 : No<br>1 : Yes   | 1<br>(0, 1)               | 250  |

## ◆ b8: Energy Saving

| No. (Hex.)                       | Name                              | Description   | Default (Range)  | Ref. |
|----------------------------------|-----------------------------------|---|--|------|
| b8-01<br>(01CC)                  | Energy Saving Control Selection   | <input checked="" type="checkbox"/> V/f <input type="checkbox"/> CL-V/f <input type="checkbox"/> OLV <input type="checkbox"/> CLV <input type="checkbox"/> AOLV <input type="checkbox"/> OLV/PM <input type="checkbox"/> AOLV/PM <input type="checkbox"/> CLV/PM <input type="checkbox"/> EZOLV<br>Sets the Energy-saving control function.<br>0 : Energy Saving Control Disabled<br>1 : Energy Saving Control Enabled<br>2 : Automatic Optimization<br><b>Note:</b><br>The Setting 2 is available only when <i>A1-02 = 6, 7 [Control Method Selection = AOLV/PM, CLV/PM]</i> and in Expert Mode. | 0<br>(0 - 2)   | 250  |
| b8-02<br>(01CD)<br>RUN<br>Expert | Energy Saving Gain                | <input type="checkbox"/> V/f <input type="checkbox"/> CL-V/f <input type="checkbox"/> OLV <input checked="" type="checkbox"/> CLV <input type="checkbox"/> AOLV <input type="checkbox"/> OLV/PM <input type="checkbox"/> AOLV/PM <input type="checkbox"/> CLV/PM <input type="checkbox"/> EZOLV<br>Sets the gain for Energy-saving control.   | Determined by A1-02<br>(0.0 - 10.0)                          | 251  |
| b8-03<br>(01CE)<br>RUN<br>Expert | Energy Saving Filter Time         | <input type="checkbox"/> V/f <input type="checkbox"/> CL-V/f <input type="checkbox"/> OLV <input checked="" type="checkbox"/> CLV <input type="checkbox"/> AOLV <input type="checkbox"/> OLV/PM <input type="checkbox"/> AOLV/PM <input type="checkbox"/> CLV/PM <input type="checkbox"/> EZOLV<br>Sets the responsiveness for Energy-saving control.   | Determined by A1-02 ,<br>C6-01 and o2-04<br>(0.00 - 10.00 s) | 251  |
| b8-04<br>(01CF)<br>Expert        | Energy Saving Coefficient Value   | <input type="checkbox"/> V/f <input type="checkbox"/> CL-V/f <input type="checkbox"/> OLV <input type="checkbox"/> CLV <input type="checkbox"/> AOLV <input type="checkbox"/> OLV/PM <input type="checkbox"/> AOLV/PM <input type="checkbox"/> CLV/PM <input type="checkbox"/> EZOLV<br>Sets the Energy-saving control coefficient to maintain maximum motor efficiency. The default setting is for Yaskawa motors.   | Determined by C6-01,<br>E2-11, and o2-04<br>(0.00 - 655.00)  | 251  |
| b8-05<br>(01D0)<br>Expert        | Power Detection Filter Time       | <input type="checkbox"/> V/f <input checked="" type="checkbox"/> CL-V/f <input type="checkbox"/> OLV <input type="checkbox"/> CLV <input type="checkbox"/> AOLV <input type="checkbox"/> OLV/PM <input type="checkbox"/> AOLV/PM <input type="checkbox"/> CLV/PM <input type="checkbox"/> EZOLV<br>Sets the time constant to measure output power.  | 20 ms<br>(0 - 2000 ms)                                       | 251  |
| b8-06<br>(01D1)<br>Expert        | PM E-Save Search Voltage Limiter  | <input type="checkbox"/> V/f <input checked="" type="checkbox"/> CL-V/f <input type="checkbox"/> OLV <input type="checkbox"/> CLV <input type="checkbox"/> AOLV <input type="checkbox"/> OLV/PM <input type="checkbox"/> AOLV/PM <input type="checkbox"/> CLV/PM <input type="checkbox"/> EZOLV<br>Sets the voltage limit for Search Operation as a percentage of the motor rated voltage.  | 0%<br>(0 - 100%)   | 251  |
| b8-16<br>(01F8)<br>Expert        | PM E-Save Coefficient Ki          | <input type="checkbox"/> V/f <input type="checkbox"/> CL-V/f <input type="checkbox"/> OLV <input type="checkbox"/> CLV <input type="checkbox"/> AOLV <input type="checkbox"/> OLV/PM <input checked="" type="checkbox"/> AOLV/PM <input type="checkbox"/> CLV/PM <input type="checkbox"/> EZOLV<br>Sets torque linearity. This parameter uses the Ki value from the motor nameplate. Usually it is not necessary to change this setting.  | 1.00<br>(0.00 - 3.00)  | 252  |
| b8-17<br>(01F9)<br>Expert        | PM E-Save Coefficient Kt          | <input type="checkbox"/> V/f <input type="checkbox"/> CL-V/f <input type="checkbox"/> OLV <input type="checkbox"/> CLV <input type="checkbox"/> AOLV <input type="checkbox"/> OLV/PM <input checked="" type="checkbox"/> AOLV/PM <input type="checkbox"/> CLV/PM <input type="checkbox"/> EZOLV<br>Sets torque linearity. This parameter uses the Kt value from the motor nameplate. Usually it is not necessary to change this setting.  | 1.00<br>(0.00 - 3.00)  | 252  |
| b8-18<br>(01FA)<br>Expert        | E-Save d-axis Current Filter Time | <input type="checkbox"/> V/f <input type="checkbox"/> CL-V/f <input type="checkbox"/> OLV <input type="checkbox"/> CLV <input type="checkbox"/> AOLV <input type="checkbox"/> OLV/PM <input checked="" type="checkbox"/> AOLV/PM <input type="checkbox"/> CLV/PM <input type="checkbox"/> EZOLV<br>Sets the d-axis current reference filter time constant.  | 0.100 s<br>(0.000 - 5.000 s)                                 | 252  |
| b8-19<br>(0B40)<br>Expert        | E-Save Search Frequency           | <input type="checkbox"/> V/f <input type="checkbox"/> CL-V/f <input type="checkbox"/> OLV <input type="checkbox"/> CLV <input type="checkbox"/> AOLV <input type="checkbox"/> OLV/PM <input checked="" type="checkbox"/> AOLV/PM <input type="checkbox"/> CLV/PM <input type="checkbox"/> EZOLV<br>Sets the frequency of Energy-saving control search operations. Usually it is not necessary to change this setting.   | Determined by A1-02<br>(10 - 300 Hz)                         | 252  |
| b8-20<br>(0B41)<br>Expert        | E-Save Search Width               | <input type="checkbox"/> V/f <input type="checkbox"/> CL-V/f <input type="checkbox"/> OLV <input type="checkbox"/> CLV <input type="checkbox"/> AOLV <input type="checkbox"/> OLV/PM <input checked="" type="checkbox"/> AOLV/PM <input type="checkbox"/> CLV/PM <input type="checkbox"/> EZOLV<br>Sets the amplitude of Energy-saving control search operations.   | 1.0 degrees<br>(0.1 - 5.0 degrees)                           | 253  |

## 1.5 b: Application

| No. (Hex.)                | Name                             | Description   | Default (Range)                      | Ref. |
|---------------------------|----------------------------------|---|--------------------------------------|------|
| b8-21<br>(0B42)<br>Expert | PM E-Save Search Gain            | <span>V/f</span> <span>CL-V/f</span> <span>OLV</span> <span>CLV</span> <span>AOLV</span> <span>OLV/PM</span> <span>AOLV/PM</span> <span>CLV/PM</span> <span>EZOLV</span><br>Sets the gain of Energy-saving control search operations.   | 0.3Hz<br>(0.1 - 20.0 Hz)             | 253  |
| b8-22<br>(0B43)<br>Expert | PM E-Save Search LPF Cutoff Freq | <span>V/f</span> <span>CL-V/f</span> <span>OLV</span> <span>CLV</span> <span>AOLV</span> <span>OLV/PM</span> <span>AOLV/PM</span> <span>CLV/PM</span> <span>EZOLV</span><br>Sets the frequency of the filter used to extract the high-efficiency phase from search operations. Usually it is not necessary to change this setting.  | 10.0 Hz<br>(1.0 - 30.0 Hz)           | 253  |
| b8-23<br>(0B44)<br>Expert | PM E-Save Search Limit           | <span>V/f</span> <span>CL-V/f</span> <span>OLV</span> <span>CLV</span> <span>AOLV</span> <span>OLV/PM</span> <span>AOLV/PM</span> <span>CLV/PM</span> <span>EZOLV</span><br>Sets the search operations output limit. Usually it is not necessary to change this setting.  | 15.0 degrees<br>(0.0 - 30.0 degrees) | 253  |
| b8-24<br>(0B45)<br>Expert | PM E-Save High Freq ACR Gain     | <span>V/f</span> <span>CL-V/f</span> <span>OLV</span> <span>CLV</span> <span>AOLV</span> <span>OLV/PM</span> <span>AOLV/PM</span> <span>CLV/PM</span> <span>EZOLV</span><br>Sets the gain for high-frequency current control.   | 200.0 Hz<br>(100.0 - 1000.0 Hz)      | 253  |
| b8-25<br>(0B46)<br>Expert | PM E-Save Search Start Level     | <span>V/f</span> <span>CL-V/f</span> <span>OLV</span> <span>CLV</span> <span>AOLV</span> <span>OLV/PM</span> <span>AOLV/PM</span> <span>CLV/PM</span> <span>EZOLV</span><br>Sets the start level for search operations.   | 10.0%<br>(0.0 - 100.0%)              | 253  |
| b8-26<br>(0B47)<br>Expert | PM E-Save Power Setpoint         | <span>V/f</span> <span>CL-V/f</span> <span>OLV</span> <span>CLV</span> <span>AOLV</span> <span>OLV/PM</span> <span>AOLV/PM</span> <span>CLV/PM</span> <span>EZOLV</span><br>Sets a value to increase torque accuracy.   | 0.0%<br>(-10.0 - +10.0%)             | 254  |
| b8-28<br>(0B8B)<br>Expert | Over Excitation Action Selection | <span>V/f</span> <span>CL-V/f</span> <span>OLV</span> <span>CLV</span> <span>AOLV</span> <span>OLV/PM</span> <span>AOLV/PM</span> <span>CLV/PM</span> <span>EZOLV</span><br>Sets the function for excitation operation.<br>0 : No<br>1 : Yes  | 0<br>(0, 1)                          | 254  |
| b8-29<br>(0B8C)           | Energy Saving Priority Selection | <span>V/f</span> <span>CL-V/f</span> <span>OLV</span> <span>CLV</span> <span>AOLV</span> <span>OLV/PM</span> <span>AOLV/PM</span> <span>CLV/PM</span> <span>EZOLV</span><br>Sets whether to prioritize tracking related to load changes or energy-saving control. Enable this to prioritize energy-saving control. Disable it to favor tracking related to rapid load changes, thereby preventing motor stall.<br>0 : No<br>1 : Yes | 0<br>(0, 1)                          | 254  |
| b8-50<br>(0B0D)           | Standby Mode Selection           | <span>V/f</span> <span>CL-V/f</span> <span>OLV</span> <span>CLV</span> <span>AOLV</span> <span>OLV/PM</span> <span>AOLV/PM</span> <span>CLV/PM</span> <span>EZOLV</span><br>Sets the Standby Mode function.<br>0 : No<br>1 : Yes  | 0<br>(0, 1)                          | 254  |
| b8-51<br>(0B01)           | Standby Mode Wait Time           | <span>V/f</span> <span>CL-V/f</span> <span>OLV</span> <span>CLV</span> <span>AOLV</span> <span>OLV/PM</span> <span>AOLV/PM</span> <span>CLV/PM</span> <span>EZOLV</span><br>Sets the delay time before turning off the electromagnetic contactor after the drive stops.   | 600 s<br>(0 - 6000 s)                | 255  |

## ◆ b9: Zero Servo

| No. (Hex.)      | Name                         | Description  | Default (Range)   | Ref. |
|-----------------|------------------------------|--|-------------------|------|
| b9-01<br>(01DA) | Zero Servo Gain              | <span>V/f</span> <span>CL-V/f</span> <span>OLV</span> <span>CLV</span> <span>AOLV</span> <span>OLV/PM</span> <span>AOLV/PM</span> <span>CLV/PM</span> <span>EZOLV</span><br>Sets the responsiveness for the Zero Servo function.   | 5<br>(0 - 100)    | 256  |
| b9-02<br>(01DB) | Zero Servo Completion Window | <span>V/f</span> <span>CL-V/f</span> <span>OLV</span> <span>CLV</span> <span>AOLV</span> <span>OLV/PM</span> <span>AOLV/PM</span> <span>CLV/PM</span> <span>EZOLV</span><br>Sets the range to trigger an output terminal set for "Zero Servo Complete" during Zero Servo operation. Be sure to set the deviation from the Zero Servo start position. | 10<br>(0 - 16383) | 256  |

## 1.6 C: Tuning

### ◆ C1: Accel & Decel Time

| No. (Hex.)             | Name                                 | Description   | Default (Range)                         | Ref. |
|------------------------|--------------------------------------|---|---|------|
| C1-01<br>(0200)<br>RUN | Acceleration Time 1                  | <b>V/f</b> <b>CL-V/f</b> <b>OLV</b> <b>CLV</b> <b>AOLV</b> <b>OLV/PM</b> <b>AOLV/PM</b> <b>CLV/PM</b> <b>EZOLV</b><br>Sets the length of time to accelerate from zero to maximum output frequency.  | 10.0 s<br>(0.0 - 6000.0 s)              | 259  |
| C1-02<br>(0201)<br>RUN | Deceleration Time 1                  | <b>V/f</b> <b>CL-V/f</b> <b>OLV</b> <b>CLV</b> <b>AOLV</b> <b>OLV/PM</b> <b>AOLV/PM</b> <b>CLV/PM</b> <b>EZOLV</b><br>Sets the length of time to decelerate from maximum output frequency to zero.  | 10.0 s<br>(0.0 - 6000.0 s)              | 259  |
| C1-03<br>(0202)<br>RUN | Acceleration Time 2                  | <b>V/f</b> <b>CL-V/f</b> <b>OLV</b> <b>CLV</b> <b>AOLV</b> <b>OLV/PM</b> <b>AOLV/PM</b> <b>CLV/PM</b> <b>EZOLV</b><br>Sets the length of time to accelerate from zero to maximum output frequency.  | 10.0 s<br>(0.0 - 6000.0 s)              | 259  |
| C1-04<br>(0203)<br>RUN | Deceleration Time 2                  | <b>V/f</b> <b>CL-V/f</b> <b>OLV</b> <b>CLV</b> <b>AOLV</b> <b>OLV/PM</b> <b>AOLV/PM</b> <b>CLV/PM</b> <b>EZOLV</b><br>Sets the length of time to decelerate from maximum output frequency to zero.  | 10.0 s<br>(0.0 - 6000.0 s)              | 259  |
| C1-05<br>(0204)<br>RUN | Acceleration Time 3                  | <b>V/f</b> <b>CL-V/f</b> <b>OLV</b> <b>CLV</b> <b>AOLV</b> <b>OLV/PM</b> <b>AOLV/PM</b> <b>CLV/PM</b> <b>EZOLV</b><br>Sets the length of time to accelerate from zero to maximum output frequency.  | 10.0 s<br>(0.0 - 6000.0 s)              | 259  |
| C1-06<br>(0205)<br>RUN | Deceleration Time 3                  | <b>V/f</b> <b>CL-V/f</b> <b>OLV</b> <b>CLV</b> <b>AOLV</b> <b>OLV/PM</b> <b>AOLV/PM</b> <b>CLV/PM</b> <b>EZOLV</b><br>Sets the length of time to decelerate from maximum output frequency to zero.  | 10.0 s<br>(0.0 - 6000.0 s)              | 259  |
| C1-07<br>(0206)<br>RUN | Acceleration Time 4                  | <b>V/f</b> <b>CL-V/f</b> <b>OLV</b> <b>CLV</b> <b>AOLV</b> <b>OLV/PM</b> <b>AOLV/PM</b> <b>CLV/PM</b> <b>EZOLV</b><br>Sets the length of time to accelerate from zero to maximum output frequency.  | 10.0 s<br>(0.0 - 6000.0 s)              | 260  |
| C1-08<br>(0207)<br>RUN | Deceleration Time 4                  | <b>V/f</b> <b>CL-V/f</b> <b>OLV</b> <b>CLV</b> <b>AOLV</b> <b>OLV/PM</b> <b>AOLV/PM</b> <b>CLV/PM</b> <b>EZOLV</b><br>Sets the length of time to decelerate from maximum output frequency to zero.  | 10.0 s<br>(0.0 - 6000.0 s)              | 260  |
| C1-09<br>(0208)<br>RUN | Fast Stop Time                       | <b>V/f</b> <b>CL-V/f</b> <b>OLV</b> <b>CLV</b> <b>AOLV</b> <b>OLV/PM</b> <b>AOLV/PM</b> <b>CLV/PM</b> <b>EZOLV</b><br>Sets the length of time that the drive will decelerate to zero for a Fast Stop.<br><b>Note:</b><br>• Decelerating too quickly can cause an <i>ov</i> [Overvoltage] fault that shuts off the drive while the motor coasts to a stop. Set a Fast Stop time in C1-09 that prevents motor coasting and makes sure that the motor stops quickly and safely.<br>• When L2-29 = 0 [Kinetic Energy Backup Method = Single Drive KEB Ride-Thru 1] and you do KEB Auto-Tuning, the drive will automatically set C1-09. If you must not change the Fast Stop time, do not do KEB Tuning. | 10.0 s<br>(0.0 - 6000.0 s)              | 260  |
| C1-10<br>(0209)        | Accel/Decel Time Setting Units       | <b>V/f</b> <b>CL-V/f</b> <b>OLV</b> <b>CLV</b> <b>AOLV</b> <b>OLV/PM</b> <b>AOLV/PM</b> <b>CLV/PM</b> <b>EZOLV</b><br>Sets the setting units for C1-01 to C1-08 [Accel/Decel Times 1 to 4], C1-09 [Fast Stop Time], L2-06 [Kinetic Energy Backup Decel Time], and L2-07 [Kinetic Energy Backup Accel Time].<br>0 : 0.01 s (0.00 to 600.00 s)<br>1 : 0.1 s (0.0 to 6000.0 s)   | 1<br>(0, 1)                             | 260  |
| C1-11<br>(020A)        | Accel/Decel Time Switching Frequency | <b>V/f</b> <b>CL-V/f</b> <b>OLV</b> <b>CLV</b> <b>AOLV</b> <b>OLV/PM</b> <b>AOLV/PM</b> <b>CLV/PM</b> <b>EZOLV</b><br>Sets the frequency at which the drive will automatically change acceleration and deceleration times.  | Determined by A1-02<br>(0.0 - 590.0 Hz) | 261  |
| C1-14<br>(0264)<br>RUN | Accel/Decel Rate Frequency           | <b>V/f</b> <b>CL-V/f</b> <b>OLV</b> <b>CLV</b> <b>AOLV</b> <b>OLV/PM</b> <b>AOLV/PM</b> <b>CLV/PM</b> <b>EZOLV</b><br>Sets the base frequency used to calculate acceleration and deceleration rates.  | 0.0 Hz<br>(0.0 - 590.0 Hz)              | 261  |

### ◆ C2: S-Curve Characteristics

| No. (Hex.)      | Name                          | Description   | Default (Range)                         | Ref. |
|-----------------|-------------------------------|---|---|------|
| C2-01<br>(020B) | S-Curve Time @ Start of Accel | <b>V/f</b> <b>CL-V/f</b> <b>OLV</b> <b>CLV</b> <b>AOLV</b> <b>OLV/PM</b> <b>AOLV/PM</b> <b>CLV/PM</b> <b>EZOLV</b><br>Sets the S-curve acceleration time at start.      | Determined by A1-02<br>(0.00 - 10.00 s) | 263  |
| C2-02<br>(020C) | S-Curve Time @ End of Accel   | <b>V/f</b> <b>CL-V/f</b> <b>OLV</b> <b>CLV</b> <b>AOLV</b> <b>OLV/PM</b> <b>AOLV/PM</b> <b>CLV/PM</b> <b>EZOLV</b><br>Sets the S-curve acceleration time at completion. | 0.20 s<br>(0.00 - 10.00 s)              | 263  |

## 1.6 C: Tuning

| No. (Hex.)   | Name                          | Description  | Default (Range)            | Ref. |
|--------------|-------------------------------|--|----------------------------|------|
| C2-03 (020D) | S-Curve Time @ Start of Decel | <input checked="" type="checkbox"/> V/f <input checked="" type="checkbox"/> CL-V/f <input checked="" type="checkbox"/> OLV <input checked="" type="checkbox"/> CLV <input checked="" type="checkbox"/> AOLV <input checked="" type="checkbox"/> OLV/PM <input checked="" type="checkbox"/> AOLV/PM <input checked="" type="checkbox"/> CLV/PM <input checked="" type="checkbox"/> EZOLV<br>Sets the S-curve deceleration time at start.      | 0.20 s<br>(0.00 - 10.00 s) | 263  |
| C2-04 (020E) | S-Curve Time @ End of Decel   | <input checked="" type="checkbox"/> V/f <input checked="" type="checkbox"/> CL-V/f <input checked="" type="checkbox"/> OLV <input checked="" type="checkbox"/> CLV <input checked="" type="checkbox"/> AOLV <input checked="" type="checkbox"/> OLV/PM <input checked="" type="checkbox"/> AOLV/PM <input checked="" type="checkbox"/> CLV/PM <input checked="" type="checkbox"/> EZOLV<br>Sets the S-curve deceleration time at completion. | 0.00 s<br>(0.00 - 10.00 s) | 263  |

### ◆ C3: Slip Compensation

| No. (Hex.)          | Name                            | Description  | Default (Range)                       | Ref. |
|---------------------|---------------------------------|--|---------------------------------------|------|
| C3-01 (020F) RUN    | Slip Compensation Gain          | <input checked="" type="checkbox"/> V/f <input checked="" type="checkbox"/> CL-V/f <input checked="" type="checkbox"/> OLV <input checked="" type="checkbox"/> CLV <input checked="" type="checkbox"/> AOLV <input checked="" type="checkbox"/> OLV/PM <input checked="" type="checkbox"/> AOLV/PM <input checked="" type="checkbox"/> CLV/PM <input checked="" type="checkbox"/> EZOLV<br>Sets the gain for the slip compensation function. Usually it is not necessary to change this setting.<br><b>Note:</b><br>Correctly set these parameters before changing the slip compensation gain:<br>• E2-01 [Motor Rated Current (FLA)]<br>• E2-02 [Motor Rated Slip]<br>• E2-03 [Motor No-Load Current]               | Determined by A1-02<br>(0.0 - 2.5)    | 264  |
| C3-02 (0210) RUN    | Slip Compensation Delay Time    | <input checked="" type="checkbox"/> V/f <input checked="" type="checkbox"/> CL-V/f <input checked="" type="checkbox"/> OLV <input checked="" type="checkbox"/> CLV <input checked="" type="checkbox"/> AOLV <input checked="" type="checkbox"/> OLV/PM <input checked="" type="checkbox"/> AOLV/PM <input checked="" type="checkbox"/> CLV/PM <input checked="" type="checkbox"/> EZOLV<br>Sets the slip compensation delay time when speed is unstable or when the slip compensation response is too slow. Usually it is not necessary to change this setting.  | Determined by A1-02<br>(0 - 10000 ms) | 264  |
| C3-03 (0211)        | Slip Compensation Limit         | <input checked="" type="checkbox"/> V/f <input checked="" type="checkbox"/> CL-V/f <input checked="" type="checkbox"/> OLV <input checked="" type="checkbox"/> CLV <input checked="" type="checkbox"/> AOLV <input checked="" type="checkbox"/> OLV/PM <input checked="" type="checkbox"/> AOLV/PM <input checked="" type="checkbox"/> CLV/PM <input checked="" type="checkbox"/> EZOLV<br>Sets the upper limit for the slip compensation function as a percentage of the motor rated slip.  | 200%<br>(0 - 250%)                    | 264  |
| C3-04 (0212)        | Slip Compensation at Regen      | <input checked="" type="checkbox"/> V/f <input checked="" type="checkbox"/> CL-V/f <input checked="" type="checkbox"/> OLV <input checked="" type="checkbox"/> CLV <input checked="" type="checkbox"/> AOLV <input checked="" type="checkbox"/> OLV/PM <input checked="" type="checkbox"/> AOLV/PM <input checked="" type="checkbox"/> CLV/PM <input checked="" type="checkbox"/> EZOLV<br>Sets the slip compensation function during regenerative operation.<br>0 : Disabled<br>1 : Enabled Above 6Hz<br>2 : Enabled Above C3-15  | 0<br>(0 - 2)                          | 265  |
| C3-05 (0213)        | Output Voltage Limit Selection  | <input checked="" type="checkbox"/> V/f <input checked="" type="checkbox"/> CL-V/f <input checked="" type="checkbox"/> OLV <input checked="" type="checkbox"/> CLV <input checked="" type="checkbox"/> AOLV <input checked="" type="checkbox"/> OLV/PM <input checked="" type="checkbox"/> AOLV/PM <input checked="" type="checkbox"/> CLV/PM <input checked="" type="checkbox"/> EZOLV<br>Sets the automatic reduction of motor magnetic flux when the output voltage is saturated.<br>0 : Disabled<br>1 : Enabled  | 0<br>(0, 1)                           | 265  |
| C3-16 (0261) Expert | Vout Modulation Limit Start Lvl | <input checked="" type="checkbox"/> V/f <input checked="" type="checkbox"/> CL-V/f <input checked="" type="checkbox"/> OLV <input checked="" type="checkbox"/> CLV <input checked="" type="checkbox"/> AOLV <input checked="" type="checkbox"/> OLV/PM <input checked="" type="checkbox"/> AOLV/PM <input checked="" type="checkbox"/> CLV/PM <input checked="" type="checkbox"/> EZOLV<br>Sets the modulation factor that starts the output voltage limit operation when C3-05 = 1 [Output Voltage Limit Selection = Enabled].  | 90.0%<br>(70.0 - 90.0%)               | 266  |
| C3-17 (0262) Expert | Vout Modulation Limit Max Level | <input checked="" type="checkbox"/> V/f <input checked="" type="checkbox"/> CL-V/f <input checked="" type="checkbox"/> OLV <input checked="" type="checkbox"/> CLV <input checked="" type="checkbox"/> AOLV <input checked="" type="checkbox"/> OLV/PM <input checked="" type="checkbox"/> AOLV/PM <input checked="" type="checkbox"/> CLV/PM <input checked="" type="checkbox"/> EZOLV<br>Sets the modulation factor used with C3-18 [Output Voltage Limit Level] for the output voltage limit operation when C3-05 = 1 [Output Voltage Limit Selection = Enabled].   | 100.0%<br>(85.0 - 100.0%)             | 266  |
| C3-18 (0263) Expert | Output Voltage Limit Level      | <input checked="" type="checkbox"/> V/f <input checked="" type="checkbox"/> CL-V/f <input checked="" type="checkbox"/> OLV <input checked="" type="checkbox"/> CLV <input checked="" type="checkbox"/> AOLV <input checked="" type="checkbox"/> OLV/PM <input checked="" type="checkbox"/> AOLV/PM <input checked="" type="checkbox"/> CLV/PM <input checked="" type="checkbox"/> EZOLV<br>Sets the maximum drop width of the voltage reference when C3-05 = 1 [Output Voltage Limit Selection = Enabled].   | 90.0%<br>(50.0 - 100.0%)              | 266  |
| C3-21 (033E) RUN    | Motor 2 Slip Compensation Gain  | <input checked="" type="checkbox"/> V/f <input checked="" type="checkbox"/> CL-V/f <input checked="" type="checkbox"/> OLV <input checked="" type="checkbox"/> CLV <input checked="" type="checkbox"/> AOLV <input checked="" type="checkbox"/> OLV/PM <input checked="" type="checkbox"/> AOLV/PM <input checked="" type="checkbox"/> CLV/PM <input checked="" type="checkbox"/> EZOLV<br>Sets the gain for the motor 2 slip compensation function. Usually it is not necessary to change this setting.<br><b>Note:</b><br>Correctly set these parameters before changing the slip compensation gain:<br>• E4-01 [Motor 2 Rated Current]<br>• E4-02 [Motor 2 Rated Slip]<br>• E4-03 [Motor 2 Rated No-Load Current] | Determined by E3-01<br>(0.0 - 2.5)    | 266  |
| C3-22 (0241) RUN    | Motor 2 Slip Comp Delay Time    | <input checked="" type="checkbox"/> V/f <input checked="" type="checkbox"/> CL-V/f <input checked="" type="checkbox"/> OLV <input checked="" type="checkbox"/> CLV <input checked="" type="checkbox"/> AOLV <input checked="" type="checkbox"/> OLV/PM <input checked="" type="checkbox"/> AOLV/PM <input checked="" type="checkbox"/> CLV/PM <input checked="" type="checkbox"/> EZOLV<br>Sets the slip compensation delay time for motor 2 when speed is unstable or when the slip compensation response is too slow. Usually it is not necessary to change this setting.  | Determined by E3-01<br>(0 - 10000 ms) | 266  |
| C3-23 (0242)        | Motor 2 Slip Compensation Limit | <input checked="" type="checkbox"/> V/f <input checked="" type="checkbox"/> CL-V/f <input checked="" type="checkbox"/> OLV <input checked="" type="checkbox"/> CLV <input checked="" type="checkbox"/> AOLV <input checked="" type="checkbox"/> OLV/PM <input checked="" type="checkbox"/> AOLV/PM <input checked="" type="checkbox"/> CLV/PM <input checked="" type="checkbox"/> EZOLV<br>Sets the upper limit for the slip compensation function as a percentage of the motor 2 rated slip.  | 200%<br>(0 - 250%)                    | 266  |

| No. (Hex.)          | Name                           | Description   | Default (Range) | Ref. |
|---------------------|--------------------------------|---|-----------------|------|
| C3-24 (0243)        | Motor 2 Slip Comp during Regen | <p><input type="checkbox"/> V/f <input type="checkbox"/> CL-V/f <input type="checkbox"/> OLV <input type="checkbox"/> CLV <input type="checkbox"/> AOLV <input type="checkbox"/> OLV/PM <input type="checkbox"/> AOLV/PM <input type="checkbox"/> CLV/PM <input type="checkbox"/> EZOLV</p> <p>Sets the slip compensation during regenerative operation function for motor 2.<br/>           0 : No<br/>           1 : Enabled Above 6Hz<br/>           2 : Enabled Above C3-15</p> | 0<br>(0 - 2)    | 267  |
| C3-28 (1B5B) Expert | Adaptive Slip Control Mode     | <p><input type="checkbox"/> V/f <input type="checkbox"/> CL-V/f <input type="checkbox"/> OLV <input checked="" type="checkbox"/> CLV <input type="checkbox"/> AOLV <input type="checkbox"/> OLV/PM <input type="checkbox"/> AOLV/PM <input type="checkbox"/> CLV/PM <input type="checkbox"/> EZOLV</p> <p>Sets the slip compensation function mode.<br/>           0 : Normal<br/>           1 : Advanced</p>   | 0<br>(0, 1)     | 267  |

#### ◆ C4: Torque Compensation

| No. (Hex.)              | Name                             | Description   | Default (Range)                       | Ref. |
|-------------------------|----------------------------------|---|---------------------------------------|------|
| C4-01 (0215) RUN        | Torque Compensation Gain         | <p><input type="checkbox"/> V/f <input type="checkbox"/> CL-V/f <input type="checkbox"/> OLV <input type="checkbox"/> CLV <input type="checkbox"/> AOLV <input checked="" type="checkbox"/> OLV/PM <input type="checkbox"/> AOLV/PM <input type="checkbox"/> CLV/PM <input type="checkbox"/> EZOLV</p> <p>Sets the gain for the torque compensation function. Use this parameter value for motor 1 when operating multiple motors.<br/> <b>Note:</b><br/>           If A1-02 = 8 [Control Method Selection = EZOLV], you cannot change the setting while the drive is running.</p>  | Determined by A1-02<br>(0.00 - 2.50)  | 268  |
| C4-02 (0216) RUN        | Torque Compensation Delay Time   | <p><input type="checkbox"/> V/f <input type="checkbox"/> CL-V/f <input type="checkbox"/> OLV <input type="checkbox"/> CLV <input type="checkbox"/> AOLV <input checked="" type="checkbox"/> OLV/PM <input type="checkbox"/> AOLV/PM <input type="checkbox"/> CLV/PM <input type="checkbox"/> EZOLV</p> <p>Sets the torque compensation delay time. Usually it is not necessary to change this setting.<br/> <b>Note:</b><br/>           If A1-02 = 8 [Control Method Selection = EZOLV], you cannot change the setting while the drive is running.</p>  | Determined by A1-02<br>(0 - 60000 ms) | 268  |
| C4-03 (0217)            | Torque Compensation @ FWD Start  | <p><input type="checkbox"/> V/f <input type="checkbox"/> CL-V/f <input checked="" type="checkbox"/> OLV <input type="checkbox"/> CLV <input type="checkbox"/> AOLV <input type="checkbox"/> OLV/PM <input type="checkbox"/> AOLV/PM <input type="checkbox"/> CLV/PM <input type="checkbox"/> EZOLV</p> <p>Set the amount of torque reference for forward start as a percentage of the motor rated torque.</p>   | 0.0%<br>(0.0 - 200.0%)                | 268  |
| C4-04 (0218)            | Torque Compensation @ REV Start  | <p><input type="checkbox"/> V/f <input type="checkbox"/> CL-V/f <input checked="" type="checkbox"/> OLV <input type="checkbox"/> CLV <input type="checkbox"/> AOLV <input type="checkbox"/> OLV/PM <input type="checkbox"/> AOLV/PM <input type="checkbox"/> CLV/PM <input type="checkbox"/> EZOLV</p> <p>Sets the amount of torque reference for reverse start as a percentage of the motor rated torque.</p>  | 0.0%<br>(-200.0 - 0.0%)               | 269  |
| C4-05 (0219)            | Torque Compensation Time         | <p><input type="checkbox"/> V/f <input type="checkbox"/> CL-V/f <input checked="" type="checkbox"/> OLV <input type="checkbox"/> CLV <input type="checkbox"/> AOLV <input type="checkbox"/> OLV/PM <input type="checkbox"/> AOLV/PM <input type="checkbox"/> CLV/PM <input type="checkbox"/> EZOLV</p> <p>Sets the starting torque constant to use with C4-03 and C4-04 [Torque Compensation @ FWD/REV Start].</p>  | 10 ms<br>(0 - 200 ms)                 | 269  |
| C4-06 (021A)            | Motor 2 Torque Comp Delay Time   | <p><input type="checkbox"/> V/f <input type="checkbox"/> CL-V/f <input checked="" type="checkbox"/> OLV <input type="checkbox"/> CLV <input type="checkbox"/> AOLV <input type="checkbox"/> OLV/PM <input type="checkbox"/> AOLV/PM <input type="checkbox"/> CLV/PM <input type="checkbox"/> EZOLV</p> <p>Sets the value if <i>ov</i> [Overvoltage] occurs with sudden changes in the load, at the end of acceleration, or at the start of deceleration.</p>  | 150 ms<br>(0 - 10000 ms)              | 269  |
| C4-07 (0341) RUN        | Motor 2 Torque Compensation Gain | <p><input type="checkbox"/> V/f <input type="checkbox"/> CL-V/f <input checked="" type="checkbox"/> OLV <input type="checkbox"/> CLV <input type="checkbox"/> AOLV <input type="checkbox"/> OLV/PM <input type="checkbox"/> AOLV/PM <input type="checkbox"/> CLV/PM <input type="checkbox"/> EZOLV</p> <p>Sets the gain for motor 2 torque compensation function when using the Motor Switch function.</p>  | 1.00<br>(0.00 - 2.50)                 | 269  |
| C4-19 (0B8D) Expert     | Torque Ripple Suppress Min Freq  | <p><input type="checkbox"/> V/f <input type="checkbox"/> CL-V/f <input checked="" type="checkbox"/> OLV <input type="checkbox"/> CLV <input type="checkbox"/> AOLV <input checked="" type="checkbox"/> OLV/PM <input type="checkbox"/> AOLV/PM <input type="checkbox"/> CLV/PM <input type="checkbox"/> EZOLV</p> <p>Adjust this if a slow oscillation occurs at low speeds. Increase this parameter in 1.0 Hz increments when current ripples and torque ripples occur during low-speed operation. Set this parameter to 0.0 to disable the function if increasing the value does not fix the problem. Usually it is not necessary to change this setting.</p> | 0.1 Hz<br>(0.0 - 10.0 Hz)             | 269  |
| C4-20 (0BCB) Expert     | Voltage Compensation Adjust 1    | <p><input type="checkbox"/> V/f <input type="checkbox"/> CL-V/f <input checked="" type="checkbox"/> OLV <input type="checkbox"/> CLV <input type="checkbox"/> AOLV <input checked="" type="checkbox"/> OLV/PM <input type="checkbox"/> AOLV/PM <input type="checkbox"/> CLV/PM <input type="checkbox"/> EZOLV</p> <p>Sets voltage precision compensation. Usually it is not necessary to change this setting.</p>   | 120<br>(0 - 200)                      | 270  |
| C4-21 (0BCC) Expert     | Voltage Compensation Adjust 2    | <p><input type="checkbox"/> V/f <input type="checkbox"/> CL-V/f <input checked="" type="checkbox"/> OLV <input type="checkbox"/> CLV <input type="checkbox"/> AOLV <input checked="" type="checkbox"/> OLV/PM <input type="checkbox"/> AOLV/PM <input type="checkbox"/> CLV/PM <input type="checkbox"/> EZOLV</p> <p>Sets voltage precision compensation. Usually it is not necessary to change this setting.</p>   | 5<br>(0 - 10)                         | 270  |
| C4-23 (1583) RUN Expert | Current Control Gain             | <p><input type="checkbox"/> V/f <input type="checkbox"/> CL-V/f <input type="checkbox"/> OLV <input checked="" type="checkbox"/> CLV <input type="checkbox"/> AOLV <input type="checkbox"/> OLV/PM <input type="checkbox"/> AOLV/PM <input type="checkbox"/> CLV/PM <input type="checkbox"/> EZOLV</p> <p>Current control gain. Usually it is not necessary to change this parameter.</p>   | 1.00<br>(0.50 - 2.50)                 | 270  |

## ◆ C5: Auto Speed Regulator (ASR)

| No. (Hex.)                | Name                             | Description   | Default (Range)  | Ref. |
|---------------------------|----------------------------------|---|--|------|
| C5-01<br>(021B)<br>RUN    | ASR Proportional Gain 1          | <input type="checkbox"/> V/f <input checked="" type="checkbox"/> CL-V/f <input type="checkbox"/> OLV <input checked="" type="checkbox"/> CLV <input type="checkbox"/> AOLV <input type="checkbox"/> OLV/PM <input type="checkbox"/> AOLV/PM <input type="checkbox"/> CLV/PM <input type="checkbox"/> EZOLV<br>Sets the gain to adjust ASR response.   | Determined by A1-02<br>(0.00 - 300.00)                                       | 274  |
| C5-02<br>(021C)<br>RUN    | ASR Integral Time 1              | <input type="checkbox"/> V/f <input checked="" type="checkbox"/> CL-V/f <input type="checkbox"/> OLV <input checked="" type="checkbox"/> CLV <input type="checkbox"/> AOLV <input type="checkbox"/> OLV/PM <input type="checkbox"/> AOLV/PM <input type="checkbox"/> CLV/PM <input type="checkbox"/> EZOLV<br>Sets the ASR integral time.   | Determined by A1-02<br>(0.000 - 60.000 s)                                    | 274  |
| C5-03<br>(021D)<br>RUN    | ASR Proportional Gain 2          | <input type="checkbox"/> V/f <input checked="" type="checkbox"/> CL-V/f <input type="checkbox"/> OLV <input checked="" type="checkbox"/> CLV <input type="checkbox"/> AOLV <input type="checkbox"/> OLV/PM <input type="checkbox"/> AOLV/PM <input type="checkbox"/> CLV/PM <input type="checkbox"/> EZOLV<br>Sets the gain to adjust ASR response.   | Determined by A1-02<br>(0.00 - 300.00)                                       | 274  |
| C5-04<br>(021E)<br>RUN    | ASR Integral Time 2              | <input type="checkbox"/> V/f <input checked="" type="checkbox"/> CL-V/f <input type="checkbox"/> OLV <input checked="" type="checkbox"/> CLV <input type="checkbox"/> AOLV <input type="checkbox"/> OLV/PM <input type="checkbox"/> AOLV/PM <input type="checkbox"/> CLV/PM <input type="checkbox"/> EZOLV<br>Sets the ASR integral time.   | Determined by A1-02<br>(0.000 - 60.000 s)                                    | 274  |
| C5-05<br>(021F)           | ASR Limit                        | <input type="checkbox"/> V/f <input checked="" type="checkbox"/> CL-V/f <input type="checkbox"/> OLV <input type="checkbox"/> CLV <input type="checkbox"/> AOLV <input type="checkbox"/> OLV/PM <input type="checkbox"/> AOLV/PM <input type="checkbox"/> CLV/PM <input type="checkbox"/> EZOLV<br>Set the ASR output limit as a percentage of E1-04 [Maximum Output Frequency].  | 5.0%<br>(0.0 - 20.0%)  | 275  |
| C5-06<br>(0220)           | ASR Delay Time                   | <input type="checkbox"/> V/f <input checked="" type="checkbox"/> CL-V/f <input type="checkbox"/> OLV <input checked="" type="checkbox"/> CLV <input type="checkbox"/> AOLV <input type="checkbox"/> OLV/PM <input type="checkbox"/> AOLV/PM <input type="checkbox"/> CLV/PM <input type="checkbox"/> EZOLV<br>Sets the filter time constant of the torque reference output from the speed loop. Usually it is not necessary to change this setting.   | Determined by A1-02<br>(0.000 - 0.500 s)                                     | 275  |
| C5-07<br>(0221)           | ASR Gain Switchover Frequency    | <input type="checkbox"/> V/f <input checked="" type="checkbox"/> CL-V/f <input type="checkbox"/> OLV <input checked="" type="checkbox"/> CLV <input type="checkbox"/> AOLV <input type="checkbox"/> OLV/PM <input type="checkbox"/> AOLV/PM <input type="checkbox"/> CLV/PM <input type="checkbox"/> EZOLV<br>Sets the frequency where the drive will switch between these parameters:<br>C5-01 and C5-03 [ASR Proportional Gain 1/2]<br>C5-02 and C5-04 [ASR Integral Time 1/2]  | Determined by A1-02<br>(Determined by A1-02)                                 | 275  |
| C5-08<br>(0222)           | ASR Integral Limit               | <input type="checkbox"/> V/f <input checked="" type="checkbox"/> CL-V/f <input type="checkbox"/> OLV <input checked="" type="checkbox"/> CLV <input type="checkbox"/> AOLV <input type="checkbox"/> OLV/PM <input type="checkbox"/> AOLV/PM <input type="checkbox"/> CLV/PM <input type="checkbox"/> EZOLV<br>Set the upper limit of the ASR integral amount as a percentage of the rated load.   | 400%<br>(0 - 400%)   | 275  |
| C5-12<br>(0386)           | Integral Operation @ Accel/Decel | <input type="checkbox"/> V/f <input checked="" type="checkbox"/> CL-V/f <input type="checkbox"/> OLV <input type="checkbox"/> CLV <input type="checkbox"/> AOLV <input type="checkbox"/> OLV/PM <input type="checkbox"/> AOLV/PM <input type="checkbox"/> CLV/PM <input type="checkbox"/> EZOLV<br>Sets ASR integral operation during acceleration and deceleration.<br>0 : No<br>1 : Yes   | 0<br>(0, 1)  | 275  |
| C5-17<br>(0276)<br>Expert | Motor Inertia                    | <input type="checkbox"/> V/f <input checked="" type="checkbox"/> CL-V/f <input type="checkbox"/> OLV <input checked="" type="checkbox"/> CLV <input type="checkbox"/> AOLV <input type="checkbox"/> OLV/PM <input type="checkbox"/> AOLV/PM <input type="checkbox"/> CLV/PM <input type="checkbox"/> EZOLV<br>Sets the motor inertia.<br><b>Note:</b><br>The default settings and the display units for setting ranges differ depending on the drive model.<br>• 0.0001 kgm <sup>2</sup> units (setting range: 0.0001 kgm <sup>2</sup> to 6.0000 kgm <sup>2</sup> ): 2004 to 2021, 4002 to 4012<br>• 0.001 kgm <sup>2</sup> units (setting range: 0.001 kgm <sup>2</sup> to 60.000 kgm <sup>2</sup> ): 2030 to 2211, 4018 to 4103<br>• 0.01 kgm <sup>2</sup> units (setting range: 0.01 kgm <sup>2</sup> to 600.00 kgm <sup>2</sup> ): 2257 to 2415, 4140 to 4720 | Determined by o2-04, C6-01, and E5-01<br>(0.0001 - 600.00 kgm <sup>2</sup> ) | 276  |
| C5-18<br>(0277)<br>Expert | Load Inertia Ratio               | <input type="checkbox"/> V/f <input checked="" type="checkbox"/> CL-V/f <input type="checkbox"/> OLV <input checked="" type="checkbox"/> CLV <input type="checkbox"/> AOLV <input type="checkbox"/> OLV/PM <input type="checkbox"/> AOLV/PM <input type="checkbox"/> CLV/PM <input type="checkbox"/> EZOLV<br>Sets the load inertia ratio for the motor inertia.  | 1.0<br>(0.0 - 6000.0)  | 276  |
| C5-21<br>(0356)<br>RUN    | Motor 2 ASR Proportional Gain 1  | <input type="checkbox"/> V/f <input checked="" type="checkbox"/> CL-V/f <input type="checkbox"/> OLV <input checked="" type="checkbox"/> CLV <input type="checkbox"/> AOLV <input type="checkbox"/> OLV/PM <input type="checkbox"/> AOLV/PM <input type="checkbox"/> CLV/PM <input type="checkbox"/> EZOLV<br>Sets the gain to adjust ASR response for motor 2.   | Determined by E3-01<br>(0.00 - 300.00)                                       | 276  |
| C5-22<br>(0357)<br>RUN    | Motor 2 ASR Integral Time 1      | <input type="checkbox"/> V/f <input checked="" type="checkbox"/> CL-V/f <input type="checkbox"/> OLV <input checked="" type="checkbox"/> CLV <input type="checkbox"/> AOLV <input type="checkbox"/> OLV/PM <input type="checkbox"/> AOLV/PM <input type="checkbox"/> CLV/PM <input type="checkbox"/> EZOLV<br>Sets the ASR integral time for motor 2.   | Determined by E3-01<br>(0.000 - 60.000 s)                                    | 276  |
| C5-23<br>(0358)<br>RUN    | Motor 2 ASR Proportional Gain 2  | <input type="checkbox"/> V/f <input checked="" type="checkbox"/> CL-V/f <input type="checkbox"/> OLV <input checked="" type="checkbox"/> CLV <input type="checkbox"/> AOLV <input type="checkbox"/> OLV/PM <input type="checkbox"/> AOLV/PM <input type="checkbox"/> CLV/PM <input type="checkbox"/> EZOLV<br>Sets the gain to adjust ASR response for motor 2.   | Determined by E3-01<br>(0.00 - 300.00)                                       | 277  |
| C5-24<br>(0359)<br>RUN    | Motor 2 ASR Integral Time 2      | <input type="checkbox"/> V/f <input checked="" type="checkbox"/> CL-V/f <input type="checkbox"/> OLV <input checked="" type="checkbox"/> CLV <input type="checkbox"/> AOLV <input type="checkbox"/> OLV/PM <input type="checkbox"/> AOLV/PM <input type="checkbox"/> CLV/PM <input type="checkbox"/> EZOLV<br>Sets the ASR integral time for motor 2.   | Determined by E3-01<br>(0.000 - 60.000 s)                                    | 277  |
| C5-25<br>(035A)           | Motor 2 ASR Limit                | <input type="checkbox"/> V/f <input checked="" type="checkbox"/> CL-V/f <input type="checkbox"/> OLV <input type="checkbox"/> CLV <input type="checkbox"/> AOLV <input type="checkbox"/> OLV/PM <input type="checkbox"/> AOLV/PM <input type="checkbox"/> CLV/PM <input type="checkbox"/> EZOLV<br>Set the motor 2 ASR output limit as a percentage of E1-04 [Maximum Output Frequency].  | 5.0%<br>(0.0 - 20.0%)  | 277  |
| C5-26<br>(035B)           | Motor 2 ASR Delay Time           | <input type="checkbox"/> V/f <input checked="" type="checkbox"/> CL-V/f <input type="checkbox"/> OLV <input checked="" type="checkbox"/> CLV <input type="checkbox"/> AOLV <input type="checkbox"/> OLV/PM <input type="checkbox"/> AOLV/PM <input type="checkbox"/> CLV/PM <input type="checkbox"/> EZOLV<br>Sets the motor 2 filter time constant of the torque reference output from the speed loop. Usually it is not necessary to change this setting.   | Determined by E3-01<br>(0.000 - 0.500 s)                                     | 277  |



| No. (Hex.)          | Name                             | Description  | Default (Range)   | Ref. |
|---------------------|----------------------------------|--|---|------|
| C5-27 (035C)        | Motor 2 ASR Gain Switchover Freq | <input type="checkbox"/> V/f <input type="checkbox"/> CL-V/f <input type="checkbox"/> OLV <input checked="" type="checkbox"/> CLV <input type="checkbox"/> AOLV <input type="checkbox"/> OLV/PM <input type="checkbox"/> AOLV/PM <input type="checkbox"/> CLV/PM <input type="checkbox"/> EZOLV<br>Sets the frequency where the drive will switch between these parameters:<br>C5-21 and C5-23 [Motor 2 ASR Proportional Gain 1 (P)/2 (P)]<br>C5-22 and C5-24 [Motor 2 ASR Integral Time 1 (I)/2 (I)]  | 0.0<br>(0.0 - 400.0)  | 277  |
| C5-28 (035D)        | Motor 2 ASR Integral Limit       | <input type="checkbox"/> V/f <input type="checkbox"/> CL-V/f <input type="checkbox"/> OLV <input checked="" type="checkbox"/> CLV <input type="checkbox"/> AOLV <input type="checkbox"/> OLV/PM <input type="checkbox"/> AOLV/PM <input type="checkbox"/> CLV/PM <input type="checkbox"/> EZOLV<br>Set the upper limit of the motor 2 ASR integral amount as a percentage of the rated load.   | 400%<br>(0 - 400%)  | 278  |
| C5-29 (0B18) Expert | Speed Control Response           | <input type="checkbox"/> V/f <input type="checkbox"/> CL-V/f <input type="checkbox"/> OLV <input checked="" type="checkbox"/> CLV <input type="checkbox"/> AOLV <input type="checkbox"/> OLV/PM <input type="checkbox"/> AOLV/PM <input type="checkbox"/> CLV/PM <input type="checkbox"/> EZOLV<br>Sets the level of speed control responsiveness. Usually it is not necessary to change this setting.<br>0 : Standard<br>1 : High Performance   | 0<br>(0, 1)   | 278  |
| C5-32 (0361)        | Motor 2 Integral Oper at Acc/Dec | <input type="checkbox"/> V/f <input checked="" type="checkbox"/> CL-V/f <input type="checkbox"/> OLV <input type="checkbox"/> CLV <input type="checkbox"/> AOLV <input type="checkbox"/> OLV/PM <input type="checkbox"/> AOLV/PM <input type="checkbox"/> CLV/PM <input type="checkbox"/> EZOLV<br>Sets ASR integral operation during acceleration and deceleration for motor 2.<br>0 : No<br>1 : Yes  | 0<br>(0, 1)   | 278  |
| C5-37 (0278) Expert | Motor 2 Inertia                  | <input type="checkbox"/> V/f <input type="checkbox"/> CL-V/f <input type="checkbox"/> OLV <input checked="" type="checkbox"/> CLV <input type="checkbox"/> AOLV <input type="checkbox"/> OLV/PM <input type="checkbox"/> AOLV/PM <input type="checkbox"/> CLV/PM <input type="checkbox"/> EZOLV<br>Sets the motor inertia for motor 2.<br><b>Note:</b><br>The default settings and the display units for setting ranges differ depending on the drive model.<br>• 0.0001 kgm <sup>2</sup> units (setting range: 0.0001 kgm <sup>2</sup> to 6.0000 kgm <sup>2</sup> ): 2004 to 2021, 4002 to 4012<br>• 0.001 kgm <sup>2</sup> units (setting range: 0.001 kgm <sup>2</sup> to 60.000 kgm <sup>2</sup> ): 2030 to 2211, 4018 to 4103<br>• 0.01 kgm <sup>2</sup> units (setting range: 0.01 kgm <sup>2</sup> to 600.00 kgm <sup>2</sup> ): 2257 to 2415, 4140 to 4720 | Determined by o2-04, C6-01<br>(0.0001 - 600.00 kgm <sup>2</sup> ) | 278  |
| C5-38 (0279) Expert | Motor 2 Load Inertia Ratio       | <input type="checkbox"/> V/f <input type="checkbox"/> CL-V/f <input type="checkbox"/> OLV <input checked="" type="checkbox"/> CLV <input type="checkbox"/> AOLV <input type="checkbox"/> OLV/PM <input type="checkbox"/> AOLV/PM <input type="checkbox"/> CLV/PM <input type="checkbox"/> EZOLV<br>Sets the load inertia ratio for the motor 2 inertia.  | 1.0<br>(0.0 - 6000.0)   | 279  |
| C5-39 (030D)        | ASR Primary Delay Time Const 2   | <input type="checkbox"/> V/f <input type="checkbox"/> CL-V/f <input type="checkbox"/> OLV <input type="checkbox"/> CLV <input type="checkbox"/> AOLV <input type="checkbox"/> OLV/PM <input type="checkbox"/> AOLV/PM <input checked="" type="checkbox"/> CLV/PM <input type="checkbox"/> EZOLV<br>Sets the filter time constant used when the torque reference is output from ASR. Usually it is not necessary to change this parameter.  | 0.000 s<br>(0.000 - 0.500 s)                                      | 279  |
| C5-50 (0B14) Expert | Notch Filter Frequency           | <input type="checkbox"/> V/f <input type="checkbox"/> CL-V/f <input type="checkbox"/> OLV <input checked="" type="checkbox"/> CLV <input type="checkbox"/> AOLV <input type="checkbox"/> OLV/PM <input type="checkbox"/> AOLV/PM <input type="checkbox"/> CLV/PM <input type="checkbox"/> EZOLV<br>Sets the machine resonance frequency.<br><b>Note:</b><br>Set C5-50 = 0 [0 Hz] to disable the notch filter.  | 0 Hz<br>(0, or 2 to 100 Hz)                                       | 279  |
| C5-51 (0B15) Expert | Notch Filter Bandwidth           | <input type="checkbox"/> V/f <input type="checkbox"/> CL-V/f <input type="checkbox"/> OLV <input checked="" type="checkbox"/> CLV <input type="checkbox"/> AOLV <input type="checkbox"/> OLV/PM <input type="checkbox"/> AOLV/PM <input type="checkbox"/> CLV/PM <input type="checkbox"/> EZOLV<br>Sets the notch width of the notch filter.<br><b>Note:</b><br>Set C5-50 = 0 [Notch Filter Frequency = 0 Hz] to disable the notch filter.   | 1.0<br>(0.5 - 5.0)  | 279  |

◆ C6: Duty & Carrier Frequency

| No. (Hex.)   | Name                            | Description  | Default (Range)  | Ref. |
|--------------|---------------------------------|--|--|------|
| C6-01 (0223) | Normal / Heavy Duty Selection   | <p><input checked="" type="checkbox"/> V/f <input checked="" type="checkbox"/> CL-V/f <input checked="" type="checkbox"/> OLV <input checked="" type="checkbox"/> CLV <input checked="" type="checkbox"/> AOLV <input checked="" type="checkbox"/> OLV/PM <input checked="" type="checkbox"/> AOLV/PM <input checked="" type="checkbox"/> CLV/PM <input checked="" type="checkbox"/> EZOLV</p> <p>Sets the drive duty rating.<br/>                     0 : Heavy Duty Rating<br/>                     1 : Normal Duty Rating</p>   | 1<br>(0, 1)  | 279  |
| C6-02 (0224) | Carrier Frequency Selection     | <p><input checked="" type="checkbox"/> V/f <input checked="" type="checkbox"/> CL-V/f <input checked="" type="checkbox"/> OLV <input checked="" type="checkbox"/> CLV <input checked="" type="checkbox"/> AOLV <input checked="" type="checkbox"/> OLV/PM <input checked="" type="checkbox"/> AOLV/PM <input checked="" type="checkbox"/> CLV/PM <input checked="" type="checkbox"/> EZOLV</p> <p>Sets the carrier frequency for the transistors in the drive.<br/>                     1 : 2.0 kHz<br/>                     2 : 5.0 kHz (4.0 kHz AOLV/PM)<br/>                     3 : 8.0 kHz (6.0 kHz AOLV/PM)<br/>                     4 : 10.0 kHz (8.0 kHz AOLV/PM)<br/>                     5 : 12.5 kHz (10.0 kHz AOLV/PM)<br/>                     6 : 15.0 kHz (12.0 kHz AOLV/PM)<br/>                     7 : Swing PWM4 (Audible Sound 1)<br/>                     8 : Swing PWM4 (Audible Sound 2)<br/>                     9 : Swing PWM4 (Audible Sound 3)<br/>                     A : Swing PWM4 (Audible Sound 4)<br/>                     F : User Defined (C6-03 to C6-05)</p> <p><b>Note:</b><br/>                     The carrier frequency for Swing PWM 1 to 4 is equivalent to 2.0 kHz.</p> | Determined by A1-02, C6-01, and o2-04<br>(Determined by A1-02) | 280  |
| C6-03 (0225) | Carrier Frequency Upper Limit   | <p><input checked="" type="checkbox"/> V/f <input checked="" type="checkbox"/> CL-V/f <input checked="" type="checkbox"/> OLV <input checked="" type="checkbox"/> CLV <input checked="" type="checkbox"/> AOLV <input checked="" type="checkbox"/> OLV/PM <input checked="" type="checkbox"/> AOLV/PM <input checked="" type="checkbox"/> CLV/PM <input checked="" type="checkbox"/> EZOLV</p> <p>Sets the upper limit of the carrier frequency. Set <math>C6-02 = F</math> [<i>Carrier Frequency Selection = User Defined (C6-03 to C6-05)</i>] to set this parameter.</p>  | Determined by C6-02<br>(1.0 - 15.0 kHz)                        | 281  |
| C6-04 (0226) | Carrier Frequency Lower Limit   | <p><input checked="" type="checkbox"/> V/f <input checked="" type="checkbox"/> CL-V/f <input checked="" type="checkbox"/> OLV <input checked="" type="checkbox"/> CLV <input checked="" type="checkbox"/> AOLV <input checked="" type="checkbox"/> OLV/PM <input checked="" type="checkbox"/> AOLV/PM <input checked="" type="checkbox"/> CLV/PM <input checked="" type="checkbox"/> EZOLV</p> <p>Sets the lower limit of the carrier frequency. Set <math>C6-02 = F</math> [<i>Carrier Frequency Selection = User Defined (C6-03 to C6-05)</i>] to set this parameter.</p>  | Determined by C6-02<br>(1.0 - 15.0 kHz)                        | 282  |
| C6-05 (0227) | Carrier Freq Proportional Gain  | <p><input checked="" type="checkbox"/> V/f <input checked="" type="checkbox"/> CL-V/f <input checked="" type="checkbox"/> OLV <input checked="" type="checkbox"/> CLV <input checked="" type="checkbox"/> AOLV <input checked="" type="checkbox"/> OLV/PM <input checked="" type="checkbox"/> AOLV/PM <input checked="" type="checkbox"/> CLV/PM <input checked="" type="checkbox"/> EZOLV</p> <p>Sets the proportional gain for the carrier frequency. Set <math>C6-02 = F</math> [<i>Carrier Frequency Selection = User Defined (C6-03 to C6-05)</i>] to set this parameter.</p>   | Determined by C6-02<br>(0 - 99)                                | 282  |
| C6-09 (022B) | Carrier Freq at Rotational Tune | <p><input checked="" type="checkbox"/> V/f <input checked="" type="checkbox"/> CL-V/f <input checked="" type="checkbox"/> OLV <input checked="" type="checkbox"/> CLV <input checked="" type="checkbox"/> AOLV <input checked="" type="checkbox"/> OLV/PM <input checked="" type="checkbox"/> AOLV/PM <input checked="" type="checkbox"/> CLV/PM <input checked="" type="checkbox"/> EZOLV</p> <p>Sets the Auto-Tuning carrier frequency. Usually it is not necessary to change this setting.<br/>                     0 : Carrier frequency 5 kHz<br/>                     1 : use C6-03</p>  | 0<br>(0, 1)  | 282  |

## 1.7 d: Reference Settings

### ◆ d1: Frequency Reference

| No. (Hex.)             | Name         | Description  | Default (Range)               | Ref. |
|------------------------|--------------|--|-------------------------------|------|
| d1-01<br>(0280)<br>RUN | Reference 1  | <p><b>V/f</b> <b>CL-V/f</b> <b>OLV</b> <b>CLV</b> <b>AOLV</b> <b>OLV/PM</b> <b>AOLV/PM</b> <b>CLV/PM</b> <b>EZOLV</b></p> <p>Sets the frequency reference in the units from <i>o1-03</i> [Frequency Display Unit Selection].</p> <p><b>Note:</b><br/>When <i>A1-02</i> = 6, 7 [Control Method Selection = AOLV/PM, CLV/PM], the drive changes <i>o1-03</i> = 1 [0.01% (100% = E1-04)].</p> | 0.00 Hz<br>(0.00 - 590.00 Hz) | 286  |
| d1-02<br>(0281)<br>RUN | Reference 2  | <p><b>V/f</b> <b>CL-V/f</b> <b>OLV</b> <b>CLV</b> <b>AOLV</b> <b>OLV/PM</b> <b>AOLV/PM</b> <b>CLV/PM</b> <b>EZOLV</b></p> <p>Sets the frequency reference in the units from <i>o1-03</i> [Frequency Display Unit Selection].</p> <p><b>Note:</b><br/>When <i>A1-02</i> = 6, 7 [Control Method Selection = AOLV/PM, CLV/PM], the drive changes <i>o1-03</i> = 1 [0.01% (100% = E1-04)].</p> | 0.00 Hz<br>(0.00 - 590.00 Hz) | 287  |
| d1-03<br>(0282)<br>RUN | Reference 3  | <p><b>V/f</b> <b>CL-V/f</b> <b>OLV</b> <b>CLV</b> <b>AOLV</b> <b>OLV/PM</b> <b>AOLV/PM</b> <b>CLV/PM</b> <b>EZOLV</b></p> <p>Sets the frequency reference in the units from <i>o1-03</i> [Frequency Display Unit Selection].</p> <p><b>Note:</b><br/>When <i>A1-02</i> = 6, 7 [Control Method Selection = AOLV/PM, CLV/PM], the drive changes <i>o1-03</i> = 1 [0.01% (100% = E1-04)].</p> | 0.00 Hz<br>(0.00 - 590.00 Hz) | 287  |
| d1-04<br>(0283)<br>RUN | Reference 4  | <p><b>V/f</b> <b>CL-V/f</b> <b>OLV</b> <b>CLV</b> <b>AOLV</b> <b>OLV/PM</b> <b>AOLV/PM</b> <b>CLV/PM</b> <b>EZOLV</b></p> <p>Sets the frequency reference in the units from <i>o1-03</i> [Frequency Display Unit Selection].</p> <p><b>Note:</b><br/>When <i>A1-02</i> = 6, 7 [Control Method Selection = AOLV/PM, CLV/PM], the drive changes <i>o1-03</i> = 1 [0.01% (100% = E1-04)].</p> | 0.00 Hz<br>(0.00 - 590.00 Hz) | 287  |
| d1-05<br>(0284)<br>RUN | Reference 5  | <p><b>V/f</b> <b>CL-V/f</b> <b>OLV</b> <b>CLV</b> <b>AOLV</b> <b>OLV/PM</b> <b>AOLV/PM</b> <b>CLV/PM</b> <b>EZOLV</b></p> <p>Sets the frequency reference in the units from <i>o1-03</i> [Frequency Display Unit Selection].</p> <p><b>Note:</b><br/>When <i>A1-02</i> = 6, 7 [Control Method Selection = AOLV/PM, CLV/PM], the drive changes <i>o1-03</i> = 1 [0.01% (100% = E1-04)].</p> | 0.00 Hz<br>(0.00 - 590.00 Hz) | 287  |
| d1-06<br>(0285)<br>RUN | Reference 6  | <p><b>V/f</b> <b>CL-V/f</b> <b>OLV</b> <b>CLV</b> <b>AOLV</b> <b>OLV/PM</b> <b>AOLV/PM</b> <b>CLV/PM</b> <b>EZOLV</b></p> <p>Sets the frequency reference in the units from <i>o1-03</i> [Frequency Display Unit Selection].</p> <p><b>Note:</b><br/>When <i>A1-02</i> = 6, 7 [Control Method Selection = AOLV/PM, CLV/PM], the drive changes <i>o1-03</i> = 1 [0.01% (100% = E1-04)].</p> | 0.00 Hz<br>(0.00 - 590.00 Hz) | 287  |
| d1-07<br>(0286)<br>RUN | Reference 7  | <p><b>V/f</b> <b>CL-V/f</b> <b>OLV</b> <b>CLV</b> <b>AOLV</b> <b>OLV/PM</b> <b>AOLV/PM</b> <b>CLV/PM</b> <b>EZOLV</b></p> <p>Sets the frequency reference in the units from <i>o1-03</i> [Frequency Display Unit Selection].</p> <p><b>Note:</b><br/>When <i>A1-02</i> = 6, 7 [Control Method Selection = AOLV/PM, CLV/PM], the drive changes <i>o1-03</i> = 1 [0.01% (100% = E1-04)].</p> | 0.00 Hz<br>(0.00 - 590.00 Hz) | 288  |
| d1-08<br>(0287)<br>RUN | Reference 8  | <p><b>V/f</b> <b>CL-V/f</b> <b>OLV</b> <b>CLV</b> <b>AOLV</b> <b>OLV/PM</b> <b>AOLV/PM</b> <b>CLV/PM</b> <b>EZOLV</b></p> <p>Sets the frequency reference in the units from <i>o1-03</i> [Frequency Display Unit Selection].</p> <p><b>Note:</b><br/>When <i>A1-02</i> = 6, 7 [Control Method Selection = AOLV/PM, CLV/PM], the drive changes <i>o1-03</i> = 1 [0.01% (100% = E1-04)].</p> | 0.00 Hz<br>(0.00 - 590.00 Hz) | 288  |
| d1-09<br>(0288)<br>RUN | Reference 9  | <p><b>V/f</b> <b>CL-V/f</b> <b>OLV</b> <b>CLV</b> <b>AOLV</b> <b>OLV/PM</b> <b>AOLV/PM</b> <b>CLV/PM</b> <b>EZOLV</b></p> <p>Sets the frequency reference in the units from <i>o1-03</i> [Frequency Display Unit Selection].</p> <p><b>Note:</b><br/>When <i>A1-02</i> = 6, 7 [Control Method Selection = AOLV/PM, CLV/PM], the drive changes <i>o1-03</i> = 1 [0.01% (100% = E1-04)].</p> | 0.00 Hz<br>(0.00 - 590.00 Hz) | 288  |
| d1-10<br>(028B)<br>RUN | Reference 10 | <p><b>V/f</b> <b>CL-V/f</b> <b>OLV</b> <b>CLV</b> <b>AOLV</b> <b>OLV/PM</b> <b>AOLV/PM</b> <b>CLV/PM</b> <b>EZOLV</b></p> <p>Sets the frequency reference in the units from <i>o1-03</i> [Frequency Display Unit Selection].</p> <p><b>Note:</b><br/>When <i>A1-02</i> = 6, 7 [Control Method Selection = AOLV/PM, CLV/PM], the drive changes <i>o1-03</i> = 1 [0.01% (100% = E1-04)].</p> | 0.00 Hz<br>(0.00 - 590.00 Hz) | 288  |
| d1-11<br>(028C)<br>RUN | Reference 11 | <p><b>V/f</b> <b>CL-V/f</b> <b>OLV</b> <b>CLV</b> <b>AOLV</b> <b>OLV/PM</b> <b>AOLV/PM</b> <b>CLV/PM</b> <b>EZOLV</b></p> <p>Sets the frequency reference in the units from <i>o1-03</i> [Frequency Display Unit Selection].</p> <p><b>Note:</b><br/>When <i>A1-02</i> = 6, 7 [Control Method Selection = AOLV/PM, CLV/PM], the drive changes <i>o1-03</i> = 1 [0.01% (100% = E1-04)].</p> | 0.00 Hz<br>(0.00 - 590.00 Hz) | 289  |

## 1.7 d: Reference Settings

| No. (Hex.)       | Name          | Description   | Default (Range)               | Ref. |
|------------------|---------------|---|-------------------------------|------|
| d1-12 (028D) RUN | Reference 12  | <p><b>V/f</b> <b>CL-V/f</b> <b>OLV</b> <b>CLV</b> <b>AOLV</b> <b>OLV/PM</b> <b>AOLV/PM</b> <b>CLV/PM</b> <b>EZOLV</b></p> <p>Sets the frequency reference in the units from <i>o1-03</i> [Frequency Display Unit Selection].</p> <p><b>Note:</b><br/>When <i>A1-02</i> = 6, 7 [Control Method Selection = AOLV/PM, CLV/PM], the drive changes <i>o1-03</i> = 1 [0.01% (100% = E1-04)].</p>  | 0.00 Hz<br>(0.00 - 590.00 Hz) | 289  |
| d1-13 (028E) RUN | Reference 13  | <p><b>V/f</b> <b>CL-V/f</b> <b>OLV</b> <b>CLV</b> <b>AOLV</b> <b>OLV/PM</b> <b>AOLV/PM</b> <b>CLV/PM</b> <b>EZOLV</b></p> <p>Sets the frequency reference in the units from <i>o1-03</i> [Frequency Display Unit Selection].</p> <p><b>Note:</b><br/>When <i>A1-02</i> = 6, 7 [Control Method Selection = AOLV/PM, CLV/PM], the drive changes <i>o1-03</i> = 1 [0.01% (100% = E1-04)].</p>  | 0.00 Hz<br>(0.00 - 590.00 Hz) | 289  |
| d1-14 (028F) RUN | Reference 14  | <p><b>V/f</b> <b>CL-V/f</b> <b>OLV</b> <b>CLV</b> <b>AOLV</b> <b>OLV/PM</b> <b>AOLV/PM</b> <b>CLV/PM</b> <b>EZOLV</b></p> <p>Sets the frequency reference in the units from <i>o1-03</i> [Frequency Display Unit Selection].</p> <p><b>Note:</b><br/>When <i>A1-02</i> = 6, 7 [Control Method Selection = AOLV/PM, CLV/PM], the drive changes <i>o1-03</i> = 1 [0.01% (100% = E1-04)].</p>  | 0.00 Hz<br>(0.00 - 590.00 Hz) | 289  |
| d1-15 (0290) RUN | Reference 15  | <p><b>V/f</b> <b>CL-V/f</b> <b>OLV</b> <b>CLV</b> <b>AOLV</b> <b>OLV/PM</b> <b>AOLV/PM</b> <b>CLV/PM</b> <b>EZOLV</b></p> <p>Sets the frequency reference in the units from <i>o1-03</i> [Frequency Display Unit Selection].</p> <p><b>Note:</b><br/>When <i>A1-02</i> = 6, 7 [Control Method Selection = AOLV/PM, CLV/PM], the drive changes <i>o1-03</i> = 1 [0.01% (100% = E1-04)].</p>  | 0.00 Hz<br>(0.00 - 590.00 Hz) | 289  |
| d1-16 (0291) RUN | Reference 16  | <p><b>V/f</b> <b>CL-V/f</b> <b>OLV</b> <b>CLV</b> <b>AOLV</b> <b>OLV/PM</b> <b>AOLV/PM</b> <b>CLV/PM</b> <b>EZOLV</b></p> <p>Sets the frequency reference in the units from <i>o1-03</i> [Frequency Display Unit Selection].</p> <p><b>Note:</b><br/>When <i>A1-02</i> = 6, 7 [Control Method Selection = AOLV/PM, CLV/PM], the drive changes <i>o1-03</i> = 1 [0.01% (100% = E1-04)].</p>  | 0.00 Hz<br>(0.00 - 590.00 Hz) | 290  |
| d1-17 (0292) RUN | Jog Reference | <p><b>V/f</b> <b>CL-V/f</b> <b>OLV</b> <b>CLV</b> <b>AOLV</b> <b>OLV/PM</b> <b>AOLV/PM</b> <b>CLV/PM</b> <b>EZOLV</b></p> <p>Sets the Jog frequency reference in the units from <i>o1-03</i> [Frequency Display Unit Selection]. Set <i>H1-xx</i> = 6 [MFDI Function Select = Jog Reference Selection] to use the Jog frequency reference.</p> <p><b>Note:</b><br/>When <i>A1-02</i> = 6, 7 [Control Method Selection = AOLV/PM, CLV/PM], the drive sets <i>o1-03</i> = 1 [0.01% (100% = E1-04)].</p> | 6.00 Hz<br>(0.00 - 590.00 Hz) | 290  |

## ◆ d2: Reference Limits

| No. (Hex.)   | Name                             | Description  | Default (Range)          | Ref. |
|--------------|----------------------------------|--|--------------------------|------|
| d2-01 (0289) | Frequency Reference Upper Limit  | <p><b>V/f</b> <b>CL-V/f</b> <b>OLV</b> <b>CLV</b> <b>AOLV</b> <b>OLV/PM</b> <b>AOLV/PM</b> <b>CLV/PM</b> <b>EZOLV</b></p> <p>Sets maximum limit for all frequency references. The maximum output frequency is 100%.</p> <p><b>Note:</b><br/>Parameter <i>A1-02</i> [Control Method Selection] selects which parameter is the maximum output frequency.<br/> <ul style="list-style-type: none"> <li>• <i>A1-02</i> ≠ 8 [EZOLV]: <i>E1-04</i> [Maximum Output Frequency]</li> <li>• <i>A1-02</i> = 8: <i>E9-02</i> [Motor Max Revolutions]</li> </ul> </p>   | 100.0%<br>(0.0 - 110.0%) | 290  |
| d2-02 (028A) | Frequency Reference Lower Limit  | <p><b>V/f</b> <b>CL-V/f</b> <b>OLV</b> <b>CLV</b> <b>AOLV</b> <b>OLV/PM</b> <b>AOLV/PM</b> <b>CLV/PM</b> <b>EZOLV</b></p> <p>Sets minimum limit for all frequency references. The maximum output frequency is 100%.</p> <p><b>Note:</b><br/>Parameter <i>A1-02</i> [Control Method Selection] selects which parameter is the maximum output frequency.<br/> <ul style="list-style-type: none"> <li>• <i>A1-02</i> ≠ 8 [EZOLV]: <i>E1-04</i> [Maximum Output Frequency]</li> <li>• <i>A1-02</i> = 8: <i>E9-02</i> [Motor Max Revolutions]</li> </ul> </p>   | 0.0%<br>(0.0 - 110.0%)   | 291  |
| d2-03 (0293) | Analog Frequency Ref Lower Limit | <p><b>V/f</b> <b>CL-V/f</b> <b>OLV</b> <b>CLV</b> <b>AOLV</b> <b>OLV/PM</b> <b>AOLV/PM</b> <b>CLV/PM</b> <b>EZOLV</b></p> <p>Sets the lower limit for the master frequency reference (the first frequency of the multi-step speed reference) as a percentage. The maximum output frequency is 100%.</p> <p><b>Note:</b><br/>Parameter <i>A1-02</i> [Control Method Selection] selects which parameter is the maximum output frequency.<br/> <ul style="list-style-type: none"> <li>• <i>A1-02</i> ≠ 8: <i>E1-04</i> [Maximum Output Frequency]</li> <li>• <i>A1-02</i> = 8: <i>E9-02</i> [Maximum Speed]</li> </ul> </p> | 0.0%<br>(0.0 - 110.0%)   | 291  |

## ◆ d3: Jump Frequency

| No. (Hex.)      | Name                 | Description  | Default (Range)                 | Ref. |
|-----------------|----------------------|--|---------------------------------|------|
| d3-01<br>(0294) | Jump Frequency 1     | <b>V/f</b> <b>CL-V/f</b> <b>OLV</b> <b>CLV</b> <b>AOLV</b> <b>OLV/PM</b> <b>AOLV/PM</b> <b>CLV/PM</b> <b>EZOLV</b><br>Sets the median value of the frequency band that the drive will avoid. | 0.0 Hz<br>(Determined by A1-02) | 292  |
| d3-02<br>(0295) | Jump Frequency 2     | <b>V/f</b> <b>CL-V/f</b> <b>OLV</b> <b>CLV</b> <b>AOLV</b> <b>OLV/PM</b> <b>AOLV/PM</b> <b>CLV/PM</b> <b>EZOLV</b><br>Sets the median value of the frequency band that the drive will avoid. | 0.0 Hz<br>(Determined by A1-02) | 292  |
| d3-03<br>(0296) | Jump Frequency 3     | <b>V/f</b> <b>CL-V/f</b> <b>OLV</b> <b>CLV</b> <b>AOLV</b> <b>OLV/PM</b> <b>AOLV/PM</b> <b>CLV/PM</b> <b>EZOLV</b><br>Sets the median value of the frequency band that the drive will avoid. | 0.0 Hz<br>(Determined by A1-02) | 292  |
| d3-04<br>(0297) | Jump Frequency Width | <b>V/f</b> <b>CL-V/f</b> <b>OLV</b> <b>CLV</b> <b>AOLV</b> <b>OLV/PM</b> <b>AOLV/PM</b> <b>CLV/PM</b> <b>EZOLV</b><br>Sets the width of the frequency band that the drive will avoid.        | 1.0 Hz<br>(Determined by A1-02) | 292  |

## ◆ d4: Frequency Ref Up/Down &amp; Hold

| No. (Hex.)             | Name                            | Description  | Default (Range)              | Ref. |
|------------------------|---------------------------------|--|------------------------------|------|
| d4-01<br>(0298)        | Freq Reference Hold Selection   | <b>V/f</b> <b>CL-V/f</b> <b>OLV</b> <b>CLV</b> <b>AOLV</b> <b>OLV/PM</b> <b>AOLV/PM</b> <b>CLV/PM</b> <b>EZOLV</b><br>Sets the function that saves the frequency reference or the frequency bias (Up/Down 2) after a Stop command or when de-energizing the drive.<br>Set <i>H1-xx</i> [ <i>MFDI Function Select</i> ] to one of these values to enable this parameter:<br>• <i>A</i> [ <i>Accel/Decel Ramp Hold</i> ]<br>• <i>10/11</i> [ <i>Up/Down Command</i> ]<br>• <i>75/76</i> [ <i>Up/Down 2 Command</i> ]<br>0 : No<br>1 : Yes  | 0<br>(0, 1)                  | 293  |
| d4-03<br>(02AA)<br>RUN | Up/Down 2 Bias Step Frequency   | <b>V/f</b> <b>CL-V/f</b> <b>OLV</b> <b>CLV</b> <b>AOLV</b> <b>OLV/PM</b> <b>AOLV/PM</b> <b>CLV/PM</b> <b>EZOLV</b><br>Sets the bias that the Up/Down 2 function adds to or subtracts from the frequency reference.   | 0.00 Hz<br>(0.00 - 99.99 Hz) | 294  |
| d4-04<br>(02AB)<br>RUN | Up/Down 2 Ramp Selection        | <b>V/f</b> <b>CL-V/f</b> <b>OLV</b> <b>CLV</b> <b>AOLV</b> <b>OLV/PM</b> <b>AOLV/PM</b> <b>CLV/PM</b> <b>EZOLV</b><br>Sets the acceleration and deceleration times for the Up/Down 2 function to apply the bias to the frequency reference.<br>0 : Use Selected Accel/Decel Time<br>1 : Use Accel/Decel Time 4   | 0<br>(0, 1)                  | 295  |
| d4-05<br>(02AC)<br>RUN | Up/Down 2 Bias Mode Selection   | <b>V/f</b> <b>CL-V/f</b> <b>OLV</b> <b>CLV</b> <b>AOLV</b> <b>OLV/PM</b> <b>AOLV/PM</b> <b>CLV/PM</b> <b>EZOLV</b><br>Sets the function that saves the bias value to the drive when you open or close the two <i>Up/Down 2 Commands</i> [ <i>H1-xx = 75, 76</i> ]. Set <i>d4-03</i> [ <i>Up/Down 2 Bias Step Frequency</i> ] = 0.00 before you set this parameter.<br>0 : Hold when Neither Up/Down Closed<br>1 : Reset when Neither / Both Closed   | 0<br>(0, 1)                  | 295  |
| d4-06<br>(02AD)        | UP/DOWN 2 Bias Value            | <b>V/f</b> <b>CL-V/f</b> <b>OLV</b> <b>CLV</b> <b>AOLV</b> <b>OLV/PM</b> <b>AOLV/PM</b> <b>CLV/PM</b> <b>EZOLV</b><br>Saves the bias value from the Up/Down 2 Command assuming that the Maximum Output Frequency is 100%.<br><b>Note:</b><br>Parameter <i>A1-02</i> [ <i>Control Method Selection</i> ] selects which parameter is the maximum output frequency.<br>• <i>A1-02</i> ≠ 8 [ <i>EZOLV</i> ]: <i>E1-04</i> [ <i>Maximum Output Frequency</i> ]<br>• <i>A1-02</i> = 8: <i>E9-02</i> [ <i>Maximum Speed</i> ]   | 0.0%<br>(-99.9 - +100.0%)    | 296  |
| d4-07<br>(02AE)<br>RUN | Analog Freq Ref Fluctuate Limit | <b>V/f</b> <b>CL-V/f</b> <b>OLV</b> <b>CLV</b> <b>AOLV</b> <b>OLV/PM</b> <b>AOLV/PM</b> <b>CLV/PM</b> <b>EZOLV</b><br>If the frequency reference changes for more than the level set to this parameter, then the bias value will be held. The value is set as a percentage of the Maximum Output Frequency.<br><b>Note:</b><br>Parameter <i>A1-02</i> [ <i>Control Method Selection</i> ] selects which parameter is the maximum output frequency.<br>• <i>A1-02</i> ≠ 8 [ <i>EZOLV</i> ]: <i>E1-04</i> [ <i>Maximum Output Frequency</i> ]<br>• <i>A1-02</i> = 8: <i>E9-02</i> [ <i>Maximum Speed</i> ] | 1.0%<br>(0.1 - 100.0%)       | 296  |
| d4-08<br>(02AF)<br>RUN | Up/Down 2 Bias Upper Limit      | <b>V/f</b> <b>CL-V/f</b> <b>OLV</b> <b>CLV</b> <b>AOLV</b> <b>OLV/PM</b> <b>AOLV/PM</b> <b>CLV/PM</b> <b>EZOLV</b><br>Sets the upper limit of the Up/Down 2 bias as a percentage of the Maximum Output Frequency.<br><b>Note:</b><br>Parameter <i>A1-02</i> [ <i>Control Method Selection</i> ] selects which parameter is the maximum output frequency.<br>• <i>A1-02</i> ≠ 8 [ <i>EZOLV</i> ]: <i>E1-04</i> [ <i>Maximum Output Frequency</i> ]<br>• <i>A1-02</i> = 8: <i>E9-02</i> [ <i>Maximum Speed</i> ]   | 100.0%<br>(0.0 - 100.0%)     | 296  |

## 1.7 d: Reference Settings

| No. (Hex.)             | Name                            | Description  | Default (Range)        | Ref. |
|------------------------|---------------------------------|--|------------------------|------|
| d4-09<br>(02B0)<br>RUN | Up/Down 2 Bias Lower Limit      | <p><input type="checkbox"/> V/f <input type="checkbox"/> CL-V/f <input type="checkbox"/> OLV <input type="checkbox"/> CLV <input checked="" type="checkbox"/> AOLV <input type="checkbox"/> OLV/PM <input type="checkbox"/> AOLV/PM <input type="checkbox"/> CLV/PM <input type="checkbox"/> EZOLV</p> <p>Sets the lower limit of the Up/Down 2 bias as a percentage of the Maximum Output Frequency.</p> <p><b>Note:</b><br/>Parameter A1-02 [Control Method Selection] selects which parameter is the maximum output frequency.<br/>• A1-02 ≠ 8 [EZOLV]: E1-04 [Maximum Output Frequency]<br/>• A1-02 = 8: E9-02 [Maximum Speed]</p> | 0.0%<br>(-99.9 - 0.0%) | 297  |
| d4-10<br>(02B6)        | Up/Down Freq Lower Limit Select | <p><input type="checkbox"/> V/f <input type="checkbox"/> CL-V/f <input type="checkbox"/> OLV <input type="checkbox"/> CLV <input checked="" type="checkbox"/> AOLV <input type="checkbox"/> OLV/PM <input type="checkbox"/> AOLV/PM <input type="checkbox"/> CLV/PM <input type="checkbox"/> EZOLV</p> <p>Sets the lower frequency limit for the Up/Down function.<br/>0 : Greater of d2-02 or Analog<br/>1 : d2-02</p>  | 0<br>(0, 1)            | 297  |

### ◆ d5: Torque Control

| No. (Hex.)      | Name                             | Description  | Default (Range)                      | Ref. |
|-----------------|----------------------------------|--|--------------------------------------|------|
| d5-01<br>(029A) | Torque Control Selection         | <p><input type="checkbox"/> V/f <input type="checkbox"/> CL-V/f <input type="checkbox"/> OLV <input checked="" type="checkbox"/> CLV <input type="checkbox"/> AOLV <input type="checkbox"/> OLV/PM <input type="checkbox"/> AOLV/PM <input type="checkbox"/> CLV/PM <input type="checkbox"/> EZOLV</p> <p>Sets the drive for torque control or speed control.<br/>0 : Speed Control<br/>1 : Torque Control</p>   | 0<br>(0, 1)                          | 301  |
| d5-02<br>(029B) | Torque Reference Delay Time      | <p><input type="checkbox"/> V/f <input type="checkbox"/> CL-V/f <input type="checkbox"/> OLV <input checked="" type="checkbox"/> CLV <input type="checkbox"/> AOLV <input type="checkbox"/> OLV/PM <input type="checkbox"/> AOLV/PM <input type="checkbox"/> CLV/PM <input type="checkbox"/> EZOLV</p> <p>Sets the primary delay time constant for the torque reference filter.</p>  | Determined by A1-02<br>(0 - 1000 ms) | 301  |
| d5-03<br>(029C) | Speed Limit Selection            | <p><input type="checkbox"/> V/f <input type="checkbox"/> CL-V/f <input type="checkbox"/> OLV <input checked="" type="checkbox"/> CLV <input type="checkbox"/> AOLV <input type="checkbox"/> OLV/PM <input type="checkbox"/> AOLV/PM <input type="checkbox"/> CLV/PM <input type="checkbox"/> EZOLV</p> <p>Sets the torque control speed limit method.<br/>1 : b1-01 Setting<br/>2 : d5-04 Setting</p>  | 1<br>(1, 2)                          | 301  |
| d5-04<br>(029D) | Speed Limit                      | <p><input type="checkbox"/> V/f <input type="checkbox"/> CL-V/f <input type="checkbox"/> OLV <input checked="" type="checkbox"/> CLV <input type="checkbox"/> AOLV <input type="checkbox"/> OLV/PM <input type="checkbox"/> AOLV/PM <input type="checkbox"/> CLV/PM <input type="checkbox"/> EZOLV</p> <p>Sets the speed limit during Torque Control as a percentage of E1-04 [Maximum Output Frequency]. Set d5-03 = 2 [Speed Limit Selection = d5-04 Setting] before you set this parameter.</p> | 0%<br>(-120 - +120%)                 | 302  |
| d5-05<br>(029E) | Speed Limit Bias                 | <p><input type="checkbox"/> V/f <input type="checkbox"/> CL-V/f <input type="checkbox"/> OLV <input checked="" type="checkbox"/> CLV <input type="checkbox"/> AOLV <input type="checkbox"/> OLV/PM <input type="checkbox"/> AOLV/PM <input type="checkbox"/> CLV/PM <input type="checkbox"/> EZOLV</p> <p>Sets the speed limit bias value as a percentage of E1-04 [Maximum Output Frequency].</p>   | 10%<br>(0 - 120%)                    | 302  |
| d5-06<br>(029F) | Speed/Torque Changeover Time     | <p><input type="checkbox"/> V/f <input type="checkbox"/> CL-V/f <input type="checkbox"/> OLV <input checked="" type="checkbox"/> CLV <input type="checkbox"/> AOLV <input type="checkbox"/> OLV/PM <input type="checkbox"/> AOLV/PM <input type="checkbox"/> CLV/PM <input type="checkbox"/> EZOLV</p> <p>Sets the delay time to switch between Speed Control and Torque Control. Set H1-xx = 71 [MFDI Function Select = Torque Control] before you set this parameter.</p>                        | 0 ms<br>(0 - 1000 ms)                | 302  |
| d5-08<br>(02B5) | Uni-directional Speed Limit Bias | <p><input type="checkbox"/> V/f <input type="checkbox"/> CL-V/f <input type="checkbox"/> OLV <input checked="" type="checkbox"/> CLV <input type="checkbox"/> AOLV <input type="checkbox"/> OLV/PM <input type="checkbox"/> AOLV/PM <input type="checkbox"/> CLV/PM <input type="checkbox"/> EZOLV</p> <p>Sets the direction of the speed limit reference to which Speed Limit Bias [d5-05] applies.<br/>0 : No<br/>1 : Yes</p>  | 1<br>(0, 1)                          | 302  |

### ◆ d6: Field Weakening /Forcing

| No. (Hex.)      | Name                            | Description   | Default (Range)            | Ref. |
|-----------------|---------------------------------|---|----------------------------|------|
| d6-01<br>(02A0) | Field Weakening Level           | <p><input type="checkbox"/> V/f <input type="checkbox"/> CL-V/f <input type="checkbox"/> OLV <input type="checkbox"/> CLV <input checked="" type="checkbox"/> AOLV <input type="checkbox"/> OLV/PM <input type="checkbox"/> AOLV/PM <input type="checkbox"/> CLV/PM <input type="checkbox"/> EZOLV</p> <p>Sets the drive output voltage as a percentage of E1-05 [Maximum Output Voltage] when H1-xx = 63 [Field Weakening] is activated.</p>   | 80%<br>(0 - 100%)          | 303  |
| d6-02<br>(02A1) | Field Weakening Frequency Limit | <p><input type="checkbox"/> V/f <input type="checkbox"/> CL-V/f <input type="checkbox"/> OLV <input type="checkbox"/> CLV <input checked="" type="checkbox"/> AOLV <input type="checkbox"/> OLV/PM <input type="checkbox"/> AOLV/PM <input type="checkbox"/> CLV/PM <input type="checkbox"/> EZOLV</p> <p>Sets the minimum output frequency to start field weakening.</p>   | 0.0 Hz<br>(0.0 - 590.0 Hz) | 303  |
| d6-03<br>(02A2) | Field Forcing Selection         | <p><input type="checkbox"/> V/f <input type="checkbox"/> CL-V/f <input type="checkbox"/> OLV <input checked="" type="checkbox"/> CLV <input type="checkbox"/> AOLV <input type="checkbox"/> OLV/PM <input type="checkbox"/> AOLV/PM <input type="checkbox"/> CLV/PM <input type="checkbox"/> EZOLV</p> <p>Sets the field forcing function.<br/>0 : No<br/>1 : Yes</p>   | 0<br>(0, 1)                | 303  |
| d6-06<br>(02A5) | Field Forcing Limit             | <p><input type="checkbox"/> V/f <input type="checkbox"/> CL-V/f <input type="checkbox"/> OLV <input checked="" type="checkbox"/> CLV <input type="checkbox"/> AOLV <input type="checkbox"/> OLV/PM <input type="checkbox"/> AOLV/PM <input type="checkbox"/> CLV/PM <input type="checkbox"/> EZOLV</p> <p>Sets the limit value for field forcing to increase the motor excitation current reference as a percentage of E2-03 [Motor No-Load Current]. Usually it is not necessary to change this setting.</p> | 400%<br>(100 - 400%)       | 303  |

## ◆ d7: Offset Frequency

| No. (Hex.)             | Name               | Description   | Default (Range)            | Ref. |
|------------------------|--------------------|---|----------------------------|------|
| d7-01<br>(02B2)<br>RUN | Offset Frequency 1 | <p><b>V/f</b> <b>CL-V/f</b> <b>OLV</b> <b>CLV</b> <b>AOLV</b> <b>OLV/PM</b> <b>AOLV/PM</b> <b>CLV/PM</b> <b>EZOLV</b></p> <p>Adds or subtracts the set frequency to/from the frequency reference using <math>HI-xx = 44</math> [MFDI Function Select = Add Offset Frequency 1 (d7-01)] as a percentage of the Maximum Output Frequency.</p> <p><b>Note:</b><br/>Parameter <math>A1-02</math> [Control Method Selection] selects which parameter is the maximum output frequency.<br/> <ul style="list-style-type: none"> <li>• <math>A1-02 \neq 8</math> [EZOLV]: <math>E1-04</math> [Maximum Output Frequency]</li> <li>• <math>A1-02 = 8</math>: <math>E9-02</math> [Maximum Speed]</li> </ul> </p> | 0.0%<br>(-100.0 - +100.0%) | 304  |
| d7-02<br>(02B3)<br>RUN | Offset Frequency 2 | <p><b>V/f</b> <b>CL-V/f</b> <b>OLV</b> <b>CLV</b> <b>AOLV</b> <b>OLV/PM</b> <b>AOLV/PM</b> <b>CLV/PM</b> <b>EZOLV</b></p> <p>Adds or subtracts the set frequency to/from the frequency reference using <math>HI-xx = 45</math> [MFDI Function Select = Add Offset Frequency 2 (d7-02)] as a percentage of the Maximum Output Frequency.</p> <p><b>Note:</b><br/>Parameter <math>A1-02</math> [Control Method Selection] selects which parameter is the maximum output frequency.<br/> <ul style="list-style-type: none"> <li>• <math>A1-02 \neq 8</math> [EZOLV]: <math>E1-04</math> [Maximum Output Frequency]</li> <li>• <math>A1-02 = 8</math>: <math>E9-02</math> [Maximum Speed]</li> </ul> </p> | 0.0%<br>(-100.0 - +100.0%) | 304  |
| d7-03<br>(02B4)<br>RUN | Offset Frequency 3 | <p><b>V/f</b> <b>CL-V/f</b> <b>OLV</b> <b>CLV</b> <b>AOLV</b> <b>OLV/PM</b> <b>AOLV/PM</b> <b>CLV/PM</b> <b>EZOLV</b></p> <p>Adds or subtracts the set frequency to/from the frequency reference using <math>HI-xx = 46</math> [MFDI Function Select = Add Offset Frequency 3 (d7-03)] as a percentage of the Maximum Output Frequency.</p> <p><b>Note:</b><br/>Parameter <math>A1-02</math> [Control Method Selection] selects which parameter is the maximum output frequency.<br/> <ul style="list-style-type: none"> <li>• <math>A1-02 \neq 8</math> [EZOLV]: <math>E1-04</math> [Maximum Output Frequency]</li> <li>• <math>A1-02 = 8</math>: <math>E9-02</math> [Maximum Speed]</li> </ul> </p> | 0.0%<br>(-100.0 - +100.0%) | 304  |

## 1.8 E: Motor Parameters

### ◆ E1: V/f Pattern for Motor 1

| No. (Hex.)          | Name                     | Description  | Default (Range)  | Ref. |
|---------------------|--------------------------|--|--|------|
| E1-01 (0300)        | Input AC Supply Voltage  | <p><b>V/f</b> <b>CL-V/f</b> <b>OLV</b> <b>CLV</b> <b>AOLV</b> <b>OLV/PM</b> <b>AOLV/PM</b> <b>CLV/PM</b> <b>EZOLV</b></p> <p>Sets the drive input voltage.</p> <p><b>NOTICE:</b> Set parameter E1-01 to align with the drive input voltage (not motor voltage). If this parameter is incorrect, the protective functions of the drive will not operate correctly and it can cause damage to the drive.</p>   | 200 V Class: 240 V, 400 V: 480 V<br>(200 V Class: 155 to 255 V, 400 V Class: 310 to 510 V)       | 306  |
| E1-03 (0302)        | V/f Pattern Selection    | <p><b>V/f</b> <b>CL-V/f</b> <b>OLV</b> <b>CLV</b> <b>AOLV</b> <b>OLV/PM</b> <b>AOLV/PM</b> <b>CLV/PM</b> <b>EZOLV</b></p> <p>Sets the V/f pattern for the drive and motor. You can use one of the preset patterns or you can make a custom pattern.</p> <p>0 : Const Trq, 50Hz base, 50Hz max<br/>1 : Const Trq, 60Hz base, 60Hz max<br/>2 : Const Trq, 50Hz base, 60Hz max<br/>3 : Const Trq, 60 Hz base, 72 Hz max<br/>4 : VT, 50Hz, 65% Vmid reduction<br/>5 : VT, 50Hz, 50% Vmid reduction<br/>6 : VT, 60 Hz, 65% Vmid reduction<br/>7 : VT, 60Hz, 50% Vmid reduction<br/>8 : High Trq, 50Hz, 25% Vmin boost<br/>9 : High Trq, 50Hz, 65% Vmin boost<br/>A : High Trq, 60Hz, 25% Vmin boost<br/>B : High Trq, 60Hz, 65% Vmin boost<br/>C : Const Trq, 60 Hz base, 90 Hz max<br/>D : Const Trq, 60 Hz base, 120 Hz max<br/>E : Const Trq, 60 Hz base, 180 Hz max<br/>F : User-defined V/f pattern</p> <p><b>Note:</b></p> <ul style="list-style-type: none"> <li>When A1-02 = 2 [Control Method Selection = OLV], settings 0 through E are not available.</li> <li>Set the correct V/f pattern for the application and operation area. An incorrect V/f pattern can decrease motor torque and increase current from overexcitation.</li> </ul> | F<br>(Determined by A1-02)   | 306  |
| E1-04 (0303)        | Maximum Output Frequency | <p><b>V/f</b> <b>CL-V/f</b> <b>OLV</b> <b>CLV</b> <b>AOLV</b> <b>OLV/PM</b> <b>AOLV/PM</b> <b>CLV/PM</b> <b>EZOLV</b></p> <p>Sets the maximum output frequency for the V/f pattern.</p>  | Determined by A1-02 and E5-01<br>(Determined by A1-02 and E5-01)                                 | 311  |
| E1-05 (0304)        | Maximum Output Voltage   | <p><b>V/f</b> <b>CL-V/f</b> <b>OLV</b> <b>CLV</b> <b>AOLV</b> <b>OLV/PM</b> <b>AOLV/PM</b> <b>CLV/PM</b> <b>EZOLV</b></p> <p>Sets the maximum output voltage for the V/f pattern.</p>  | 200 V Class: 230.0 V, 400 V: 460.0 V<br>(200 V Class: 0.0 - 255.0 V, 400 V Class: 0.0 - 510.0 V) | 312  |
| E1-06 (0305)        | Base Frequency           | <p><b>V/f</b> <b>CL-V/f</b> <b>OLV</b> <b>CLV</b> <b>AOLV</b> <b>OLV/PM</b> <b>AOLV/PM</b> <b>CLV/PM</b> <b>EZOLV</b></p> <p>Sets the base frequency for the V/f pattern.</p>  | Determined by A1-02 and E5-01<br>(0.0 - E1-04)   | 312  |
| E1-07 (0306)        | Mid Point A Frequency    | <p><b>V/f</b> <b>CL-V/f</b> <b>OLV</b> <b>CLV</b> <b>AOLV</b> <b>OLV/PM</b> <b>AOLV/PM</b> <b>CLV/PM</b> <b>EZOLV</b></p> <p>Sets a middle output frequency for the V/f pattern.</p>   | Determined by A1-02<br>(0.0 - E1-04)   | 312  |
| E1-08 (0307)        | Mid Point A Voltage      | <p><b>V/f</b> <b>CL-V/f</b> <b>OLV</b> <b>CLV</b> <b>AOLV</b> <b>OLV/PM</b> <b>AOLV/PM</b> <b>CLV/PM</b> <b>EZOLV</b></p> <p>Sets a middle output voltage for the V/f pattern.</p>   | Determined by A1-02, C6-01 and o2-04<br>(200 V Class: 0.0 - 255.0 V, 400 V Class: 0.0 - 510.0 V) | 312  |
| E1-09 (0308)        | Minimum Output Frequency | <p><b>V/f</b> <b>CL-V/f</b> <b>OLV</b> <b>CLV</b> <b>AOLV</b> <b>OLV/PM</b> <b>AOLV/PM</b> <b>CLV/PM</b> <b>EZOLV</b></p> <p>Sets the minimum output frequency for the V/f pattern.</p>  | Determined by A1-02 and E5-01<br>(Determined by A1-02, E1-04, and E5-01)                         | 312  |
| E1-10 (0309)        | Minimum Output Voltage   | <p><b>V/f</b> <b>CL-V/f</b> <b>OLV</b> <b>CLV</b> <b>AOLV</b> <b>OLV/PM</b> <b>AOLV/PM</b> <b>CLV/PM</b> <b>EZOLV</b></p> <p>Sets the minimum output voltage for the V/f pattern.</p>  | Determined by A1-02<br>(200 V Class: 0.0 to 255.0 V, 400 V Class: 0.0 to 510.0 V)                | 312  |
| E1-11 (030A) Expert | Mid Point B Frequency    | <p><b>V/f</b> <b>CL-V/f</b> <b>OLV</b> <b>CLV</b> <b>AOLV</b> <b>OLV/PM</b> <b>AOLV/PM</b> <b>CLV/PM</b> <b>EZOLV</b></p> <p>Sets a middle output frequency for the V/f pattern.</p>   | 0.0 Hz<br>(0.0 - E1-04)  | 312  |



| No. (Hex.)          | Name                | Description  | Default (Range)   | Ref. |
|---------------------|---------------------|--|---|------|
| E1-12 (030B) Expert | Mid Point B Voltage | <b>V/f</b> <b>CL-V/f</b> <b>OLV</b> <b>CLV</b> <b>AOLV</b> <b>OLV/PM</b> <b>AOLV/PM</b> <b>CLV/PM</b> <b>EZOLV</b><br>Sets a middle point voltage for the V/f pattern. | 0.0 V<br>(200 V Class: 0.0 to 255.0 V, 400 V Class: 0.0 to 510.0 V) | 313  |
| E1-13 (030C) Expert | Base Voltage        | <b>V/f</b> <b>CL-V/f</b> <b>OLV</b> <b>CLV</b> <b>AOLV</b> <b>OLV/PM</b> <b>AOLV/PM</b> <b>CLV/PM</b> <b>EZOLV</b><br>Sets the base voltage for the V/f pattern.       | 0.0 V<br>(200 V Class: 0.0 - 255.0 V, 400 V Class: 0.0 - 510.0 V)   | 313  |

◆ E2: Motor Parameters

| No. (Hex.)          | Name                           | Description   | Default (Range)  | Ref. |
|---------------------|--------------------------------|---|--|------|
| E2-01 (030E)        | Motor Rated Current (FLA)      | <b>V/f</b> <b>CL-V/f</b> <b>OLV</b> <b>CLV</b> <b>AOLV</b> <b>OLV/PM</b> <b>AOLV/PM</b> <b>CLV/PM</b> <b>EZOLV</b><br>Sets the motor rated current in amps.   | Determined by o2-04, C6-01<br>(10% to 200% of the drive rated current) | 313  |
| E2-02 (030F)        | Motor Rated Slip               | <b>V/f</b> <b>CL-V/f</b> <b>OLV</b> <b>CLV</b> <b>AOLV</b> <b>OLV/PM</b> <b>AOLV/PM</b> <b>CLV/PM</b> <b>EZOLV</b><br>Sets motor rated slip.  | Determined by o2-04, C6-01<br>(0.000 - 20.000 Hz)                      | 313  |
| E2-03 (0310)        | Motor No-Load Current          | <b>V/f</b> <b>CL-V/f</b> <b>OLV</b> <b>CLV</b> <b>AOLV</b> <b>OLV/PM</b> <b>AOLV/PM</b> <b>CLV/PM</b> <b>EZOLV</b><br>Sets the no-load current for the motor in amps when operating at the rated frequency and the no-load voltage.   | Determined by o2-04, C6-01<br>(0 to E2-01)                             | 314  |
| E2-04 (0311)        | Motor Pole Count               | <b>V/f</b> <b>CL-V/f</b> <b>OLV</b> <b>CLV</b> <b>AOLV</b> <b>OLV/PM</b> <b>AOLV/PM</b> <b>CLV/PM</b> <b>EZOLV</b><br>Sets the number of motor poles.<br><b>Note:</b><br>• When A1-02 = 0, 1, 3 [Control Method Selection = V/f, CL-V/f, CLV], the maximum value is 120.<br>• When A1-02 = 2, 4 [OLV, AOLV], the maximum value is 48. | 4<br>(2 - 120)   | 314  |
| E2-05 (0312)        | Motor Line-to-Line Resistance  | <b>V/f</b> <b>CL-V/f</b> <b>OLV</b> <b>CLV</b> <b>AOLV</b> <b>OLV/PM</b> <b>AOLV/PM</b> <b>CLV/PM</b> <b>EZOLV</b><br>Sets the line-to-line resistance for the motor stator windings.   | Determined by o2-04, C6-01<br>(0.000 - 65.000 Ω)                       | 314  |
| E2-06 (0313)        | Motor Leakage Inductance       | <b>V/f</b> <b>CL-V/f</b> <b>OLV</b> <b>CLV</b> <b>AOLV</b> <b>OLV/PM</b> <b>AOLV/PM</b> <b>CLV/PM</b> <b>EZOLV</b><br>Sets the voltage drop from motor leakage inductance when the motor is operating at the rated frequency and rated current. This value is a percentage of Motor Rated Voltage.                                    | Determined by o2-04, C6-01<br>(0.0 - 60.0%)                            | 315  |
| E2-07 (0314)        | Motor Saturation Coefficient 1 | <b>V/f</b> <b>CL-V/f</b> <b>OLV</b> <b>CLV</b> <b>AOLV</b> <b>OLV/PM</b> <b>AOLV/PM</b> <b>CLV/PM</b> <b>EZOLV</b><br>Sets the motor iron-core saturation coefficient at 50% of the magnetic flux.  | 0.50<br>(0.00 - 0.50)  | 315  |
| E2-08 (0315)        | Motor Saturation Coefficient 2 | <b>V/f</b> <b>CL-V/f</b> <b>OLV</b> <b>CLV</b> <b>AOLV</b> <b>OLV/PM</b> <b>AOLV/PM</b> <b>CLV/PM</b> <b>EZOLV</b><br>Sets the motor iron-core saturation coefficient at 75% of the magnetic flux.  | 0.75<br>(E2-07 - 0.75)   | 315  |
| E2-09 (0316) Expert | Motor Mechanical Loss          | <b>V/f</b> <b>CL-V/f</b> <b>OLV</b> <b>CLV</b> <b>AOLV</b> <b>OLV/PM</b> <b>AOLV/PM</b> <b>CLV/PM</b> <b>EZOLV</b><br>Sets the mechanical loss of the motor. It is set as a percentage of E2-11 [Motor Rated Power]. Usually it is not necessary to change this setting.  | 0.0%<br>(0.0 - 10.0%)  | 315  |
| E2-10 (0317)        | Motor Iron Loss                | <b>V/f</b> <b>CL-V/f</b> <b>OLV</b> <b>CLV</b> <b>AOLV</b> <b>OLV/PM</b> <b>AOLV/PM</b> <b>CLV/PM</b> <b>EZOLV</b><br>Sets the motor iron loss.   | Determined by o2-04, C6-01<br>(0 - 65535 W)                            | 315  |
| E2-11 (0318)        | Motor Rated Power              | <b>V/f</b> <b>CL-V/f</b> <b>OLV</b> <b>CLV</b> <b>AOLV</b> <b>OLV/PM</b> <b>AOLV/PM</b> <b>CLV/PM</b> <b>EZOLV</b><br>Sets the motor rated output in the units from o1-58 [Motor Power Unit Selection].   | Determined by o2-04, C6-01<br>(0.00 - 650.00)                          | 315  |

## 1.8 E: Motor Parameters

### ◆ E3: V/f Pattern for Motor 2

| No. (Hex.)          | Name                             | Description   | Default (Range)  | Ref. |
|---------------------|----------------------------------|---|--|------|
| E3-01 (0319)        | Motor 2 Control Mode Selection   | <p><b>V/f</b> <b>CL-V/f</b> <b>OLV</b> <b>CLV</b> <b>AOLV</b> <b>OLV/PM</b> <b>AOLV/PM</b> <b>CLV/PM</b> <b>EZOLV</b></p> <p>Sets the control method for motor 2.</p> <p><b>Note:</b><br/>When you change this setting, the drive will set all parameters that are dependent on this parameter to their default settings.</p> <p>0 : V/f Control<br/>1 : V/f Control with Encoder<br/>2 : Open Loop Vector<br/>3 : Closed Loop Vector</p> | 0<br>(0 - 3)   | 316  |
| E3-04 (031A)        | Motor 2 Maximum Output Frequency | <p><b>V/f</b> <b>CL-V/f</b> <b>OLV</b> <b>CLV</b> <b>AOLV</b> <b>OLV/PM</b> <b>AOLV/PM</b> <b>CLV/PM</b> <b>EZOLV</b></p> <p>Set the maximum output frequency for the motor 2 V/f pattern.</p>  | Determined by E3-01<br>(40.0 - 590.0 Hz)   | 316  |
| E3-05 (031B)        | Motor 2 Maximum Output Voltage   | <p><b>V/f</b> <b>CL-V/f</b> <b>OLV</b> <b>CLV</b> <b>AOLV</b> <b>OLV/PM</b> <b>AOLV/PM</b> <b>CLV/PM</b> <b>EZOLV</b></p> <p>Sets the maximum output voltage for the motor 2 V/f pattern.</p>   | Determined by E3-01<br>(200 V Class: 0.0 - 255.0 V <sub>V</sub><br>400 V Class: 0.0 - 510.0 V) | 317  |
| E3-06 (031C)        | Motor 2 Base Frequency           | <p><b>V/f</b> <b>CL-V/f</b> <b>OLV</b> <b>CLV</b> <b>AOLV</b> <b>OLV/PM</b> <b>AOLV/PM</b> <b>CLV/PM</b> <b>EZOLV</b></p> <p>Sets the base frequency for the motor 2 V/f pattern.</p>   | Determined by E3-01<br>(0.0 - E3-04)   | 317  |
| E3-07 (031D)        | Motor 2 Mid Point A Frequency    | <p><b>V/f</b> <b>CL-V/f</b> <b>OLV</b> <b>CLV</b> <b>AOLV</b> <b>OLV/PM</b> <b>AOLV/PM</b> <b>CLV/PM</b> <b>EZOLV</b></p> <p>Sets a middle output frequency for the motor 2 V/f pattern.</p>  | Determined by E3-01<br>(0.0 - E3-04)   | 317  |
| E3-08 (031E)        | Motor 2 Mid Point A Voltage      | <p><b>V/f</b> <b>CL-V/f</b> <b>OLV</b> <b>CLV</b> <b>AOLV</b> <b>OLV/PM</b> <b>AOLV/PM</b> <b>CLV/PM</b> <b>EZOLV</b></p> <p>Sets a middle output voltage for the motor 2 V/f pattern.</p>  | Determined by E3-01<br>(200 V Class: 0.0 - 255.0 V <sub>V</sub><br>400 V Class: 0.0 - 510.0 V) | 317  |
| E3-09 (031F)        | Motor 2 Minimum Output Frequency | <p><b>V/f</b> <b>CL-V/f</b> <b>OLV</b> <b>CLV</b> <b>AOLV</b> <b>OLV/PM</b> <b>AOLV/PM</b> <b>CLV/PM</b> <b>EZOLV</b></p> <p>Sets the minimum output frequency for the motor 2 V/f pattern.</p>   | Determined by E3-01<br>(0.0 - E3-04)   | 317  |
| E3-10 (0320)        | Motor 2 Minimum Output Voltage   | <p><b>V/f</b> <b>CL-V/f</b> <b>OLV</b> <b>CLV</b> <b>AOLV</b> <b>OLV/PM</b> <b>AOLV/PM</b> <b>CLV/PM</b> <b>EZOLV</b></p> <p>Sets the minimum output voltage for the motor 2 V/f pattern.</p>   | Determined by E3-01<br>(200 V Class: 0.0 - 255.0 V <sub>V</sub><br>400 V Class: 0.0 - 510.0 V) | 317  |
| E3-11 (0345) Expert | Motor 2 Mid Point B Frequency    | <p><b>V/f</b> <b>CL-V/f</b> <b>OLV</b> <b>CLV</b> <b>AOLV</b> <b>OLV/PM</b> <b>AOLV/PM</b> <b>CLV/PM</b> <b>EZOLV</b></p> <p>Sets a middle output frequency for the motor 2 V/f pattern. Set this parameter to adjust the V/f pattern for the constant output range. Usually it is not necessary to change this parameter.</p>  | 0.0 Hz<br>(0.0 - E3-04)  | 317  |
| E3-12 (0346) Expert | Motor 2 Mid Point B Voltage      | <p><b>V/f</b> <b>CL-V/f</b> <b>OLV</b> <b>CLV</b> <b>AOLV</b> <b>OLV/PM</b> <b>AOLV/PM</b> <b>CLV/PM</b> <b>EZOLV</b></p> <p>Sets a middle output voltage for the motor 2 V/f pattern. Set this parameter to adjust the V/f pattern for the constant output range. Usually it is not necessary to change this parameter.</p>  | 0.0 V<br>(200 V Class: 0.0 to 255.0 V, 400 V Class: 0.0 to 510.0 V)                            | 318  |
| E3-13 (0347) Expert | Motor 2 Base Voltage             | <p><b>V/f</b> <b>CL-V/f</b> <b>OLV</b> <b>CLV</b> <b>AOLV</b> <b>OLV/PM</b> <b>AOLV/PM</b> <b>CLV/PM</b> <b>EZOLV</b></p> <p>Sets the base voltage for the motor 2 V/f pattern. Set this parameter to adjust the V/f pattern for the constant output range. Usually it is not necessary to change this parameter.</p>   | 0.0 V<br>(200 V Class: 0.0 to 255.0 V, 400 V Class: 0.0 to 510.0 V)                            | 318  |

### ◆ E4: Motor 2 Parameters

| No. (Hex.)   | Name                          | Description  | Default (Range)  | Ref. |
|--------------|-------------------------------|--|--|------|
| E4-01 (0321) | Motor 2 Rated Current         | <p><b>V/f</b> <b>CL-V/f</b> <b>OLV</b> <b>CLV</b> <b>AOLV</b> <b>OLV/PM</b> <b>AOLV/PM</b> <b>CLV/PM</b> <b>EZOLV</b></p> <p>Sets the motor rated current for motor 2 in amps.</p>   | Determined by o2-04, C6-01<br>(10% to 200% of the drive rated current) | 318  |
| E4-02 (0322) | Motor 2 Rated Slip            | <p><b>V/f</b> <b>CL-V/f</b> <b>OLV</b> <b>CLV</b> <b>AOLV</b> <b>OLV/PM</b> <b>AOLV/PM</b> <b>CLV/PM</b> <b>EZOLV</b></p> <p>Sets the motor rated slip for motor 2.</p>  | Determined by o2-04, C6-01<br>(0.000 - 20.000 Hz)                      | 318  |
| E4-03 (0323) | Motor 2 Rated No-Load Current | <p><b>V/f</b> <b>CL-V/f</b> <b>OLV</b> <b>CLV</b> <b>AOLV</b> <b>OLV/PM</b> <b>AOLV/PM</b> <b>CLV/PM</b> <b>EZOLV</b></p> <p>Sets the no-load current for motor 2 in amps when operating at the rated frequency and the no-load voltage.</p> | Determined by o2-04, C6-01<br>(Less than 0 - E4-01)                    | 319  |
| E4-04 (0324) | Motor 2 Motor Poles           | <p><b>V/f</b> <b>CL-V/f</b> <b>OLV</b> <b>CLV</b> <b>AOLV</b> <b>OLV/PM</b> <b>AOLV/PM</b> <b>CLV/PM</b> <b>EZOLV</b></p> <p>Sets the number of poles for motor 2.</p>   | 4<br>(2 - 120)   | 319  |

| No. (Hex.)          | Name                             | Description  | Default (Range)                                  | Ref. |
|---------------------|----------------------------------|--|--|------|
| E4-05 (0325)        | Motor 2 Line-to-Line Resistance  | <input type="checkbox"/> V/f <input type="checkbox"/> CL-V/f <input type="checkbox"/> OLV <input type="checkbox"/> CLV <input type="checkbox"/> AOLV <input type="checkbox"/> OLV/PM <input type="checkbox"/> AOLV/PM <input type="checkbox"/> CLV/PM <input type="checkbox"/> EZOLV<br>Sets the line-to-line resistance for the motor 2 stator windings.  | Determined by o2-04, C6-01<br>(0.000 - 65.000 Ω) | 319  |
| E4-06 (0326)        | Motor 2 Leakage Inductance       | <input type="checkbox"/> V/f <input type="checkbox"/> CL-V/f <input type="checkbox"/> OLV <input type="checkbox"/> CLV <input type="checkbox"/> AOLV <input type="checkbox"/> OLV/PM <input type="checkbox"/> AOLV/PM <input type="checkbox"/> CLV/PM <input type="checkbox"/> EZOLV<br>Sets the voltage drop from motor 2 leakage inductance as a percentage of Motor Rated Voltage when motor 2 operates at the rated frequency and rated current. | Determined by o2-04, C6-01<br>(0.0 - 60.0%)      | 319  |
| E4-07 (0343)        | Motor 2 Saturation Coefficient 1 | <input type="checkbox"/> V/f <input type="checkbox"/> CL-V/f <input type="checkbox"/> OLV <input type="checkbox"/> CLV <input type="checkbox"/> AOLV <input type="checkbox"/> OLV/PM <input type="checkbox"/> AOLV/PM <input type="checkbox"/> CLV/PM <input type="checkbox"/> EZOLV<br>Sets the motor 2 iron-core saturation coefficient at 50% of the magnetic flux.   | 0.50<br>(0.00 - 0.50)                            | 320  |
| E4-08 (0344)        | Motor 2 Saturation Coefficient 2 | <input type="checkbox"/> V/f <input type="checkbox"/> CL-V/f <input type="checkbox"/> OLV <input type="checkbox"/> CLV <input type="checkbox"/> AOLV <input type="checkbox"/> OLV/PM <input type="checkbox"/> AOLV/PM <input type="checkbox"/> CLV/PM <input type="checkbox"/> EZOLV<br>Sets the motor 2 iron-core saturation coefficient at 75% of the magnetic flux.   | 0.75<br>(E4-07 - 0.75)                           | 320  |
| E4-09 (033F) Expert | Motor 2 Mechanical Loss          | <input type="checkbox"/> V/f <input type="checkbox"/> CL-V/f <input type="checkbox"/> OLV <input type="checkbox"/> CLV <input type="checkbox"/> AOLV <input type="checkbox"/> OLV/PM <input type="checkbox"/> AOLV/PM <input type="checkbox"/> CLV/PM <input type="checkbox"/> EZOLV<br>Sets the mechanical loss of motor 2. It is set as a percentage of E4-11 [Motor 2 Rated Power]. Usually it is not necessary to change this setting.           | 0.0%<br>(0.0 - 10.0%)                            | 320  |
| E4-10 (0340)        | Motor 2 Iron Loss                | <input type="checkbox"/> V/f <input type="checkbox"/> CL-V/f <input type="checkbox"/> OLV <input type="checkbox"/> CLV <input type="checkbox"/> AOLV <input type="checkbox"/> OLV/PM <input type="checkbox"/> AOLV/PM <input type="checkbox"/> CLV/PM <input type="checkbox"/> EZOLV<br>Sets the motor iron loss for motor 2.  | Determined by o2-04, C6-01<br>(0 - 65535 W)      | 320  |
| E4-11 (0327)        | Motor 2 Rated Power              | <input type="checkbox"/> V/f <input type="checkbox"/> CL-V/f <input type="checkbox"/> OLV <input type="checkbox"/> CLV <input type="checkbox"/> AOLV <input type="checkbox"/> OLV/PM <input type="checkbox"/> AOLV/PM <input type="checkbox"/> CLV/PM <input type="checkbox"/> EZOLV<br>Sets the motor rated power in the units from o1-58 [Motor Power Unit Selection].   | Determined by o2-04, C6-01<br>(0.00 - 650.00 kW) | 320  |

◆ E5: PM Motor Settings

| No. (Hex.)          | Name                             | Description   | Default (Range)   | Ref. |
|---------------------|----------------------------------|---|---|------|
| E5-01 (0329)        | PM Motor Code Selection          | <input type="checkbox"/> V/f <input type="checkbox"/> CL-V/f <input type="checkbox"/> OLV <input type="checkbox"/> CLV <input type="checkbox"/> AOLV <input checked="" type="checkbox"/> OLV/PM <input checked="" type="checkbox"/> AOLV/PM <input checked="" type="checkbox"/> CLV/PM <input type="checkbox"/> EZOLV<br>Sets the motor code for Yaskawa PM motors. The drive uses the motor code to set some parameters to their correct settings automatically.   | FFFF<br>(0000 - FFFF)   | 321  |
| E5-02 (032A)        | PM Motor Rated Power (kW)        | <input type="checkbox"/> V/f <input type="checkbox"/> CL-V/f <input type="checkbox"/> OLV <input type="checkbox"/> CLV <input type="checkbox"/> AOLV <input checked="" type="checkbox"/> OLV/PM <input checked="" type="checkbox"/> AOLV/PM <input checked="" type="checkbox"/> CLV/PM <input type="checkbox"/> EZOLV<br>Sets the PM motor rated output in the unit set by o1-58 [Motor Power Unit Selection].  | Determined by E5-01<br>(0.10 - 650.00 kW)                       | 321  |
| E5-03 (032B)        | PM Motor Rated Current (FLA)     | <input type="checkbox"/> V/f <input type="checkbox"/> CL-V/f <input type="checkbox"/> OLV <input type="checkbox"/> CLV <input type="checkbox"/> AOLV <input checked="" type="checkbox"/> OLV/PM <input checked="" type="checkbox"/> AOLV/PM <input checked="" type="checkbox"/> CLV/PM <input type="checkbox"/> EZOLV<br>Sets the PM motor rated current (FLA).   | Determined by E5-01<br>(10% to 200% of the drive rated current) | 321  |
| E5-04 (032C)        | PM Motor Pole Count              | <input type="checkbox"/> V/f <input type="checkbox"/> CL-V/f <input type="checkbox"/> OLV <input type="checkbox"/> CLV <input type="checkbox"/> AOLV <input checked="" type="checkbox"/> OLV/PM <input checked="" type="checkbox"/> AOLV/PM <input checked="" type="checkbox"/> CLV/PM <input type="checkbox"/> EZOLV<br>Sets the number of PM motor poles.<br><b>Note:</b><br>• When A1-02 = 7 [Control Method Selection = CLV/PM], the maximum value is 120.<br>• When A1-02 = 5, 6 or 8 [OLV/PM, AOLV/PM or EZOLV], the maximum value is 48. | 4<br>(2 - 120)  | 321  |
| E5-05 (032D)        | PM Motor Resistance (ohms/phase) | <input type="checkbox"/> V/f <input type="checkbox"/> CL-V/f <input type="checkbox"/> OLV <input type="checkbox"/> CLV <input type="checkbox"/> AOLV <input checked="" type="checkbox"/> OLV/PM <input checked="" type="checkbox"/> AOLV/PM <input checked="" type="checkbox"/> CLV/PM <input type="checkbox"/> EZOLV<br>Sets the resistance per phase of the PM motors. Set 50% of the line-to-line resistance.  | Determined by E5-01<br>(0.000 - 65.000 Ω)                       | 322  |
| E5-06 (032E)        | PM d-axis Inductance (mH/phase)  | <input type="checkbox"/> V/f <input type="checkbox"/> CL-V/f <input type="checkbox"/> OLV <input type="checkbox"/> CLV <input type="checkbox"/> AOLV <input checked="" type="checkbox"/> OLV/PM <input checked="" type="checkbox"/> AOLV/PM <input checked="" type="checkbox"/> CLV/PM <input type="checkbox"/> EZOLV<br>Sets the PM motor d-axis inductance.   | Determined by E5-01<br>(0.00 - 300.00 mH)                       | 322  |
| E5-07 (032F)        | PM q-axis Inductance (mH/phase)  | <input type="checkbox"/> V/f <input type="checkbox"/> CL-V/f <input type="checkbox"/> OLV <input type="checkbox"/> CLV <input type="checkbox"/> AOLV <input checked="" type="checkbox"/> OLV/PM <input checked="" type="checkbox"/> AOLV/PM <input checked="" type="checkbox"/> CLV/PM <input type="checkbox"/> EZOLV<br>Sets the PM motor q-axis inductance.   | Determined by E5-01<br>(0.00 - 600.00 mH)                       | 322  |
| E5-09 (0331)        | PM Back-EMF Vpeak (mV/(rad/s))   | <input type="checkbox"/> V/f <input type="checkbox"/> CL-V/f <input type="checkbox"/> OLV <input type="checkbox"/> CLV <input type="checkbox"/> AOLV <input checked="" type="checkbox"/> OLV/PM <input checked="" type="checkbox"/> AOLV/PM <input checked="" type="checkbox"/> CLV/PM <input type="checkbox"/> EZOLV<br>Sets the peak value of PM motor induced voltage.   | Determined by E5-01<br>(0.0 - 2000.0 mV/(rad/s))                | 322  |
| E5-11 (0333)        | Encoder Z-Pulse Offset           | <input type="checkbox"/> V/f <input type="checkbox"/> CL-V/f <input type="checkbox"/> OLV <input type="checkbox"/> CLV <input type="checkbox"/> AOLV <input type="checkbox"/> OLV/PM <input type="checkbox"/> AOLV/PM <input checked="" type="checkbox"/> CLV/PM <input type="checkbox"/> EZOLV<br>Sets the encoder Z-pulse offset.   | 0.0 degrees<br>(-180.0 - +180.0 degrees)                        | 323  |
| E5-24 (0353)        | PM Back-EMF L-L Vrms (mV/rpm)    | <input type="checkbox"/> V/f <input type="checkbox"/> CL-V/f <input type="checkbox"/> OLV <input type="checkbox"/> CLV <input type="checkbox"/> AOLV <input checked="" type="checkbox"/> OLV/PM <input checked="" type="checkbox"/> AOLV/PM <input checked="" type="checkbox"/> CLV/PM <input type="checkbox"/> EZOLV<br>Sets the RMS value for PM motor line voltage.  | Determined by E5-01<br>(0.0 - 6500.0 mV/min <sup>-1</sup> )     | 323  |
| E5-25 (035E) Expert | Polarity Estimation Timeout      | <input type="checkbox"/> V/f <input type="checkbox"/> CL-V/f <input type="checkbox"/> OLV <input type="checkbox"/> CLV <input type="checkbox"/> AOLV <input checked="" type="checkbox"/> OLV/PM <input checked="" type="checkbox"/> AOLV/PM <input checked="" type="checkbox"/> CLV/PM <input type="checkbox"/> EZOLV<br>Sets the function that switches polarity for initial polarity estimation. Usually it is not necessary to change this setting.<br>0 : Disabled<br>1 : Enabled   | 0<br>(0, 1)   | 323  |

Parameter List

## 1.8 E: Motor Parameters

### ◆ E9: Motor Setting

| No. (Hex.)      | Name                          | Description   | Default (Range)  | Ref. |
|-----------------|-------------------------------|---|--|------|
| E9-01<br>(11E4) | Motor Type Selection          | <div style="display: flex; justify-content: space-between; font-size: 8px;"> <span>V/f</span> <span>CL-V/f</span> <span>OLV</span> <span>CLV</span> <span>AOLV</span> <span>OLV/PM</span> <span>AOLV/PM</span> <span>CLV/PM</span> <span style="background-color: black; color: white; padding: 2px;">EZOLV</span> </div> <p>Sets the type of motor.<br/>           0 : Induction (IM)<br/>           1 : Permanent Magnet (PM)<br/>           2 : Synchronous Reluctance (SynRM)</p> | 0<br>(0 to 2)  | 323  |
| E9-02<br>(11E5) | Motor Max Revolutions         | <div style="display: flex; justify-content: space-between; font-size: 8px;"> <span>V/f</span> <span>CL-V/f</span> <span>OLV</span> <span>CLV</span> <span>AOLV</span> <span>OLV/PM</span> <span>AOLV/PM</span> <span>CLV/PM</span> <span style="background-color: black; color: white; padding: 2px;">EZOLV</span> </div> <p>Sets the maximum speed of the motor.</p>   | Determined by E9-01<br>(40.0 - 120.0 Hz)   | 324  |
| E9-03<br>(11E6) | Motor Rated Revolutions       | <div style="display: flex; justify-content: space-between; font-size: 8px;"> <span>V/f</span> <span>CL-V/f</span> <span>OLV</span> <span>CLV</span> <span>AOLV</span> <span>OLV/PM</span> <span>AOLV/PM</span> <span>CLV/PM</span> <span style="background-color: black; color: white; padding: 2px;">EZOLV</span> </div> <p>Sets the rated rotation speed of the motor.</p>  | Determined by E9-01<br>(100 - 7200 min <sup>-1</sup> )   | 324  |
| E9-04<br>(11E7) | Motor Rated Frequency         | <div style="display: flex; justify-content: space-between; font-size: 8px;"> <span>V/f</span> <span>CL-V/f</span> <span>OLV</span> <span>CLV</span> <span>AOLV</span> <span>OLV/PM</span> <span>AOLV/PM</span> <span>CLV/PM</span> <span style="background-color: black; color: white; padding: 2px;">EZOLV</span> </div> <p>Sets the rated frequency of the motor.</p>   | Determined by E9-01<br>(40.0 - 120.0 Hz)   | 324  |
| E9-05<br>(11E8) | Motor Rated Voltage           | <div style="display: flex; justify-content: space-between; font-size: 8px;"> <span>V/f</span> <span>CL-V/f</span> <span>OLV</span> <span>CLV</span> <span>AOLV</span> <span>OLV/PM</span> <span>AOLV/PM</span> <span>CLV/PM</span> <span style="background-color: black; color: white; padding: 2px;">EZOLV</span> </div> <p>Sets the rated voltage of the motor.</p>   | 200 V Class: 230.0 V, 400 V: 460.0 V<br>(200 V Class: 0.0 - 255.0 V, 400 V Class: 0.0 - 510.0 V) | 324  |
| E9-06<br>(11E9) | Motor Rated Current (FLA)     | <div style="display: flex; justify-content: space-between; font-size: 8px;"> <span>V/f</span> <span>CL-V/f</span> <span>OLV</span> <span>CLV</span> <span>AOLV</span> <span>OLV/PM</span> <span>AOLV/PM</span> <span>CLV/PM</span> <span style="background-color: black; color: white; padding: 2px;">EZOLV</span> </div> <p>Sets the motor rated current in amps.</p>  | Determined by E9-01 and o2-04<br>(10% to 200% of the drive rated current)                        | 324  |
| E9-07<br>(11EA) | PM Motor Rated Power (kW)     | <div style="display: flex; justify-content: space-between; font-size: 8px;"> <span>V/f</span> <span>CL-V/f</span> <span>OLV</span> <span>CLV</span> <span>AOLV</span> <span>OLV/PM</span> <span>AOLV/PM</span> <span>CLV/PM</span> <span style="background-color: black; color: white; padding: 2px;">EZOLV</span> </div> <p>Sets the motor rated power in the units from o1-58 [Motor Power Unit Selection].</p>   | Determined by E9-02 and o2-04<br>(0.00 - 650.00 kW)  | 325  |
| E9-08<br>(11EB) | Motor Pole Count              | <div style="display: flex; justify-content: space-between; font-size: 8px;"> <span>V/f</span> <span>CL-V/f</span> <span>OLV</span> <span>CLV</span> <span>AOLV</span> <span>OLV/PM</span> <span>AOLV/PM</span> <span>CLV/PM</span> <span style="background-color: black; color: white; padding: 2px;">EZOLV</span> </div> <p>Sets the number of motor poles.</p>  | 4<br>(2 to 120)  | 325  |
| E9-09<br>(11EC) | Motor Rated Slip              | <div style="display: flex; justify-content: space-between; font-size: 8px;"> <span>V/f</span> <span>CL-V/f</span> <span>OLV</span> <span>CLV</span> <span>AOLV</span> <span>OLV/PM</span> <span>AOLV/PM</span> <span>CLV/PM</span> <span style="background-color: black; color: white; padding: 2px;">EZOLV</span> </div> <p>Sets the motor rated slip.</p>   | 0.000 Hz<br>(0.000 - 20.000 Hz)  | 325  |
| E9-10<br>(11ED) | Motor Line-to-Line Resistance | <div style="display: flex; justify-content: space-between; font-size: 8px;"> <span>V/f</span> <span>CL-V/f</span> <span>OLV</span> <span>CLV</span> <span>AOLV</span> <span>OLV/PM</span> <span>AOLV/PM</span> <span>CLV/PM</span> <span style="background-color: black; color: white; padding: 2px;">EZOLV</span> </div> <p>Sets the line-to-line resistance for the motor stator windings.</p>  | Determined by o2-04<br>(0.000 - 65.000 Ω)  | 325  |

## 1.9 F: Options

### ◆ F1: Encoder Option Setup

| No. (Hex.)   | Name                             | Description   | Default (Range)                          | Ref. |
|--------------|----------------------------------|---|--|------|
| F1-01 (0380) | Encoder 1 Pulse Count (PPR)      | <input type="checkbox"/> V/f <input checked="" type="checkbox"/> CL-V/f <input type="checkbox"/> OLV <input type="checkbox"/> CLV <input type="checkbox"/> AOLV <input type="checkbox"/> OLV/PM <input type="checkbox"/> AOLV/PM <input type="checkbox"/> CLV/PM <input type="checkbox"/> EZOLV<br>Sets the number of output pulses for each motor revolution.  | 1024 ppr<br>(1 - 60000 ppr)              | 327  |
| F1-02 (0381) | Encoder Signal Loss Detect Sel   | <input type="checkbox"/> V/f <input checked="" type="checkbox"/> CL-V/f <input type="checkbox"/> OLV <input type="checkbox"/> CLV <input type="checkbox"/> AOLV <input type="checkbox"/> OLV/PM <input type="checkbox"/> AOLV/PM <input type="checkbox"/> CLV/PM <input type="checkbox"/> EZOLV<br>Sets the method to stop the motor or let the motor continue operating when the drive detects a PGo [Encoder (PG) Feedback Loss].<br>0 : Ramp to Stop<br>1 : Coast to Stop<br>2 : Fast Stop<br>3 : Alarm Only<br>4 : No Alarm Display   | 1<br>(0 - 4)                             | 327  |
| F1-03 (0382) | Overspeed Detection Selection    | <input type="checkbox"/> V/f <input checked="" type="checkbox"/> CL-V/f <input type="checkbox"/> OLV <input type="checkbox"/> CLV <input type="checkbox"/> AOLV <input type="checkbox"/> OLV/PM <input type="checkbox"/> AOLV/PM <input type="checkbox"/> CLV/PM <input type="checkbox"/> EZOLV<br>Sets the method to stop the motor or let the motor continue operating when the drive detects a oS [Overspeed].<br>0 : Ramp to Stop<br>1 : Coast to Stop<br>2 : Fast Stop<br>3 : Alarm Only   | 1<br>(0 - 3)                             | 327  |
| F1-04 (0383) | Speed Deviation Detection Select | <input type="checkbox"/> V/f <input checked="" type="checkbox"/> CL-V/f <input type="checkbox"/> OLV <input type="checkbox"/> CLV <input type="checkbox"/> AOLV <input type="checkbox"/> OLV/PM <input type="checkbox"/> AOLV/PM <input type="checkbox"/> CLV/PM <input type="checkbox"/> EZOLV<br>Sets the method to stop the motor or let the motor continue operating when the drive detects a dEv [Speed Deviation].<br>0 : Ramp to Stop<br>1 : Coast to Stop<br>2 : Fast Stop<br>3 : Alarm Only  | 3<br>(0 - 3)                             | 328  |
| F1-05 (0384) | Encoder 1 Rotation Selection     | <input type="checkbox"/> V/f <input checked="" type="checkbox"/> CL-V/f <input type="checkbox"/> OLV <input type="checkbox"/> CLV <input type="checkbox"/> AOLV <input type="checkbox"/> OLV/PM <input type="checkbox"/> AOLV/PM <input type="checkbox"/> CLV/PM <input type="checkbox"/> EZOLV<br>Sets the output sequence for the A and B pulses from the encoder, assuming that the motor is operating in the forward direction.<br>0 : Pulse A leads in FWD Direction<br>1 : Pulse B leads in FWD Direction   | Determined by A1-02<br>(0, 1)            | 328  |
| F1-06 (0385) | Encoder 1 Pulse Monitor Scaling  | <input type="checkbox"/> V/f <input checked="" type="checkbox"/> CL-V/f <input type="checkbox"/> OLV <input type="checkbox"/> CLV <input type="checkbox"/> AOLV <input type="checkbox"/> OLV/PM <input type="checkbox"/> AOLV/PM <input type="checkbox"/> CLV/PM <input type="checkbox"/> EZOLV<br>Sets the ratio between the pulse input and the pulse output of the encoder as a 3-digit number. The first digit is the numerator and the second and third digits set the denominator. The dividing ratio = (1 + x)/yz when the setting value is a 3-digit value (xyz).   | 001<br>(001 - 032, 102 - 132 (1 - 1/32)) | 329  |
| F1-08 (0387) | Overspeed Detection Level        | <input type="checkbox"/> V/f <input checked="" type="checkbox"/> CL-V/f <input type="checkbox"/> OLV <input type="checkbox"/> CLV <input type="checkbox"/> AOLV <input type="checkbox"/> OLV/PM <input type="checkbox"/> AOLV/PM <input type="checkbox"/> CLV/PM <input type="checkbox"/> EZOLV<br>Sets the detection level of oS [Overspeed] as a percentage when the maximum output frequency is 100%.<br><b>Note:</b><br>Parameter A1-02 [Control Method Selection] selects which parameter is the maximum output frequency.<br>• A1-02 ≠ 8 [EZOLV]: E1-04 [Maximum Output Frequency]<br>• A1-02 = 8: E9-02 [Maximum Speed]        | 115%<br>(0 - 120%)                       | 329  |
| F1-09 (0388) | Overspeed Detection Delay Time   | <input type="checkbox"/> V/f <input checked="" type="checkbox"/> CL-V/f <input type="checkbox"/> OLV <input type="checkbox"/> CLV <input type="checkbox"/> AOLV <input type="checkbox"/> OLV/PM <input type="checkbox"/> AOLV/PM <input type="checkbox"/> CLV/PM <input type="checkbox"/> EZOLV<br>Sets the length of time that the speed feedback must be more than the F1-08 level to cause an oS [Overspeed].  | Determined by A1-02<br>(0.0 - 2.0 s)     | 329  |
| F1-10 (0389) | Speed Deviation Detection Level  | <input type="checkbox"/> V/f <input checked="" type="checkbox"/> CL-V/f <input type="checkbox"/> OLV <input type="checkbox"/> CLV <input type="checkbox"/> AOLV <input type="checkbox"/> OLV/PM <input type="checkbox"/> AOLV/PM <input type="checkbox"/> CLV/PM <input type="checkbox"/> EZOLV<br>Sets the detection level of dEv [Speed Deviation] as a percentage when the maximum output frequency is 100%.<br><b>Note:</b><br>Parameter A1-02 [Control Method Selection] selects which parameter is the maximum output frequency.<br>• A1-02 ≠ 8 [EZOLV]: E1-04 [Maximum Output Frequency]<br>• A1-02 = 8: E9-02 [Maximum Speed] | 10%<br>(0 - 50%)                         | 329  |
| F1-11 (038A) | Speed Deviation Detect DelayTime | <input type="checkbox"/> V/f <input checked="" type="checkbox"/> CL-V/f <input type="checkbox"/> OLV <input type="checkbox"/> CLV <input type="checkbox"/> AOLV <input type="checkbox"/> OLV/PM <input type="checkbox"/> AOLV/PM <input type="checkbox"/> CLV/PM <input type="checkbox"/> EZOLV<br>Sets the length of time that the difference between the frequency reference and speed feedback must be more than the level in F1-10 to cause a dEv [Speed Deviation].  | 0.5 s<br>(0.0 - 10.0 s)                  | 329  |
| F1-12 (038B) | Encoder 1 Gear Teeth 1           | <input type="checkbox"/> V/f <input checked="" type="checkbox"/> CL-V/f <input type="checkbox"/> OLV <input type="checkbox"/> CLV <input type="checkbox"/> AOLV <input type="checkbox"/> OLV/PM <input type="checkbox"/> AOLV/PM <input type="checkbox"/> CLV/PM <input type="checkbox"/> EZOLV<br>Sets the number of gear teeth on the motor side. This parameter and F1-13 [Encoder 1 Gear Teeth 2] set the gear ratio between the motor and encoder.   | 0<br>(0 - 1000)                          | 329  |

## 1.9 F: Options

| No. (Hex.)   | Name                             | Description  | Default (Range)                          | Ref. |
|--------------|----------------------------------|--|--|------|
| F1-13 (038C) | Encoder 2 Gear Teeth 1           | <input type="checkbox"/> V/f <input checked="" type="checkbox"/> CL-V/f <input type="checkbox"/> OLV <input type="checkbox"/> CLV <input type="checkbox"/> AOLV <input type="checkbox"/> OLV/PM <input type="checkbox"/> AOLV/PM <input type="checkbox"/> CLV/PM <input type="checkbox"/> EZOLV<br>Sets the number of gear teeth on the load side. This parameter and F1-12 [Encoder 1 Gear Teeth 1] set the gear ratio between the motor and encoder.   | 0<br>(0 - 1000)                          | 330  |
| F1-14 (038D) | Encoder Open-Circuit Detect Time | <input type="checkbox"/> V/f <input checked="" type="checkbox"/> CL-V/f <input type="checkbox"/> OLV <input checked="" type="checkbox"/> CLV <input type="checkbox"/> AOLV <input type="checkbox"/> OLV/PM <input type="checkbox"/> AOLV/PM <input checked="" type="checkbox"/> CLV/PM <input type="checkbox"/> EZOLV<br>Sets the length of time that the drive must not receive a pulse signal to cause a PGo [Encoder (PG) Feedback Loss].<br><b>Note:</b><br>Motor speed and load conditions can cause ov [Overvoltage] and oC [Overcurrent] faults.  | 2.0 s<br>(0.0 - 10.0 s)                  | 330  |
| F1-18 (03AD) | Deviation 3 Detection Selection  | <input type="checkbox"/> V/f <input type="checkbox"/> CL-V/f <input type="checkbox"/> OLV <input type="checkbox"/> CLV <input type="checkbox"/> AOLV <input type="checkbox"/> OLV/PM <input type="checkbox"/> AOLV/PM <input checked="" type="checkbox"/> CLV/PM <input type="checkbox"/> EZOLV<br>Sets the number of rotations necessary to detect conditions that invert the torque reference and rate of acceleration and cause dv3 [Inversion Detection].  | 10<br>(0 - 10)                           | 330  |
| F1-19 (03AE) | Deviation 4 Detection Selection  | <input type="checkbox"/> V/f <input type="checkbox"/> CL-V/f <input type="checkbox"/> OLV <input type="checkbox"/> CLV <input type="checkbox"/> AOLV <input type="checkbox"/> OLV/PM <input type="checkbox"/> AOLV/PM <input checked="" type="checkbox"/> CLV/PM <input type="checkbox"/> EZOLV<br>Sets the number of pulses necessary to cause dv4 [Inversion Prevention Detection].  | 128<br>(0 - 5000)                        | 330  |
| F1-20 (03B4) | Encoder 1 PCB Disconnect Detect  | <input type="checkbox"/> V/f <input checked="" type="checkbox"/> CL-V/f <input type="checkbox"/> OLV <input checked="" type="checkbox"/> CLV <input type="checkbox"/> AOLV <input type="checkbox"/> OLV/PM <input type="checkbox"/> AOLV/PM <input checked="" type="checkbox"/> CLV/PM <input type="checkbox"/> EZOLV<br>Sets the function that enables and disables detection of a disconnected encoder connection cable to cause PGoH [Encoder (PG) Hardware Fault].<br>0 : No<br>1 : Yes  | 1<br>(0, 1)                              | 331  |
| F1-21 (03BC) | Encoder 1 Signal Selection       | <input type="checkbox"/> V/f <input checked="" type="checkbox"/> CL-V/f <input type="checkbox"/> OLV <input type="checkbox"/> CLV <input type="checkbox"/> AOLV <input type="checkbox"/> OLV/PM <input type="checkbox"/> AOLV/PM <input checked="" type="checkbox"/> CLV/PM <input type="checkbox"/> EZOLV<br>Sets the number of channels for the signal to the encoder option card.<br>0 : A Pulse Detection<br>1 : AB Pulse Detection  | 0<br>(0, 1)                              | 331  |
| F1-30 (03AA) | Motor 2 Encoder PCB Port Select  | <input type="checkbox"/> V/f <input checked="" type="checkbox"/> CL-V/f <input type="checkbox"/> OLV <input checked="" type="checkbox"/> CLV <input type="checkbox"/> AOLV <input type="checkbox"/> OLV/PM <input type="checkbox"/> AOLV/PM <input checked="" type="checkbox"/> CLV/PM <input type="checkbox"/> EZOLV<br>Sets the drive port to install the motor 2 encoder option card.<br>0 : CNS-C<br>1 : CNS-B   | 1<br>(0, 1)                              | 331  |
| F1-31 (03B0) | Encoder 2 Pulse Count (PPR)      | <input type="checkbox"/> V/f <input checked="" type="checkbox"/> CL-V/f <input type="checkbox"/> OLV <input checked="" type="checkbox"/> CLV <input type="checkbox"/> AOLV <input type="checkbox"/> OLV/PM <input type="checkbox"/> AOLV/PM <input checked="" type="checkbox"/> CLV/PM <input type="checkbox"/> EZOLV<br>Sets the number of output pulses for each motor revolution for motor 2.   | 1024 ppr<br>(1 - 60000 ppr)              | 331  |
| F1-32 (03B1) | Encoder 2 Rotation Selection     | <input type="checkbox"/> V/f <input checked="" type="checkbox"/> CL-V/f <input type="checkbox"/> OLV <input checked="" type="checkbox"/> CLV <input type="checkbox"/> AOLV <input type="checkbox"/> OLV/PM <input type="checkbox"/> AOLV/PM <input checked="" type="checkbox"/> CLV/PM <input type="checkbox"/> EZOLV<br>Sets the output sequence for the A and B pulses from the encoder for motor 2. This parameter assumes that the motor is operating in the forward direction.<br>0 : Pulse A leads in FWD Direction<br>1 : Pulse B leads in FWD Direction  | 0<br>(0, 1)                              | 331  |
| F1-33 (03B2) | Encoder 2 Gear Teeth 1           | <input type="checkbox"/> V/f <input checked="" type="checkbox"/> CL-V/f <input type="checkbox"/> OLV <input type="checkbox"/> CLV <input type="checkbox"/> AOLV <input type="checkbox"/> OLV/PM <input type="checkbox"/> AOLV/PM <input type="checkbox"/> CLV/PM <input type="checkbox"/> EZOLV<br>Sets the number of gear teeth on the motor side for motor 2. This parameter and F1-34 [Encoder 2 Gear Teeth 2] set the gear ratio between the motor and encoder.  | 0<br>(0 - 1000)                          | 332  |
| F1-34 (03B3) | Encoder 2 Gear Teeth 2           | <input type="checkbox"/> V/f <input checked="" type="checkbox"/> CL-V/f <input type="checkbox"/> OLV <input type="checkbox"/> CLV <input type="checkbox"/> AOLV <input type="checkbox"/> OLV/PM <input type="checkbox"/> AOLV/PM <input type="checkbox"/> CLV/PM <input type="checkbox"/> EZOLV<br>Sets the number of gear teeth on the load side for motor 2. This parameter and F1-33 [Encoder 2 Gear Teeth 1] set the gear ratio between the motor and encoder.   | 0<br>(0 - 1000)                          | 332  |
| F1-35 (03BE) | Encoder 2 Pulse Monitor Scaling  | <input type="checkbox"/> V/f <input checked="" type="checkbox"/> CL-V/f <input type="checkbox"/> OLV <input checked="" type="checkbox"/> CLV <input type="checkbox"/> AOLV <input type="checkbox"/> OLV/PM <input type="checkbox"/> AOLV/PM <input checked="" type="checkbox"/> CLV/PM <input type="checkbox"/> EZOLV<br>Sets the ratio between the pulse input and the pulse output of the encoder as a 3-digit number for motor 2. The first digit is the numerator and the second and third digits set the denominator.<br>The dividing ratio = (1 + x)/yz when the setting value is a 3-digit value (xyz). | 001<br>(001 - 032, 102 - 132 (1 - 1/32)) | 332  |
| F1-36 (03B5) | Encoder 2 PCB Disconnect Detect  | <input type="checkbox"/> V/f <input checked="" type="checkbox"/> CL-V/f <input type="checkbox"/> OLV <input checked="" type="checkbox"/> CLV <input type="checkbox"/> AOLV <input type="checkbox"/> OLV/PM <input type="checkbox"/> AOLV/PM <input checked="" type="checkbox"/> CLV/PM <input type="checkbox"/> EZOLV<br>Sets the function that enables and disables detection of a disconnected encoder connection cable to cause PGoH [Encoder (PG) Hardware Fault] for motor 2.<br>0 : No<br>1 : Yes  | 1<br>(0, 1)                              | 332  |
| F1-37 (03BD) | Encoder 2 Signal Selection       | <input type="checkbox"/> V/f <input checked="" type="checkbox"/> CL-V/f <input type="checkbox"/> OLV <input type="checkbox"/> CLV <input type="checkbox"/> AOLV <input type="checkbox"/> OLV/PM <input type="checkbox"/> AOLV/PM <input checked="" type="checkbox"/> CLV/PM <input type="checkbox"/> EZOLV<br>Sets the number of channels for the signal to the encoder option card for motor 2.<br>0 : A Pulse Detection<br>1 : AB Pulse Detection  | 0<br>(0, 1)                              | 332  |
| F1-50 (03D2) | PG-F3 Option Encoder Type        | <input type="checkbox"/> V/f <input type="checkbox"/> CL-V/f <input type="checkbox"/> OLV <input type="checkbox"/> CLV <input type="checkbox"/> AOLV <input type="checkbox"/> OLV/PM <input type="checkbox"/> AOLV/PM <input checked="" type="checkbox"/> CLV/PM <input type="checkbox"/> EZOLV<br>Sets the type of encoder connected to the PG-F3 option.<br>0 : EnDat Sin/Cos<br>1 : EnDat Serial Only<br>2 : HIPERFACE  | 0<br>(0 - 2)                             | 333  |

| No. (Hex.)   | Name                       | Description   | Default (Range)   | Ref. |
|--------------|----------------------------|---|-------------------|------|
| F1-51 (03D3) | PG-F3 PGoH Detection Level | <p><b>V/f</b> <b>CL-V/f</b> <b>OLV</b> <b>CLV</b> <b>AOLV</b> <b>OLV/PM</b> <b>AOLV/PM</b> <b>CLV/PM</b> <b>EZOLV</b></p> <p>The drive will detect PGoH [Encoder (PG) Hardware Fault] if the value of this parameter is smaller than the value of <math>\sqrt{\sin^2\theta + \cos^2\theta}</math>.</p> <p><b>Note:</b><br/>This function is enabled when F1-20 = 1 [PG Hardware Disconnection Detection Selection = Enabled].</p> | 80%<br>(1 - 100%) | 333  |
| F1-52 (03D4) | Serial Encoder Comm Speed  | <p><b>V/f</b> <b>CL-V/f</b> <b>OLV</b> <b>CLV</b> <b>AOLV</b> <b>OLV/PM</b> <b>AOLV/PM</b> <b>CLV/PM</b> <b>EZOLV</b></p> <p>Sets the communication speed between the PG-F3 option and the serial encoder.</p> <p>0 : 1M/9600bps<br/>1 : 500k/19200bps<br/>2 : 1M/38400bps</p>  | 0<br>(0 - 2)      | 333  |

## ◆ F2: Analog Input Option

| No. (Hex.)       | Name                            | Description   | Default (Range)              | Ref. |
|------------------|---------------------------------|---|------------------------------|------|
| F2-01 (038F)     | Analog Input Function Selection | <p><b>V/f</b> <b>CL-V/f</b> <b>OLV</b> <b>CLV</b> <b>AOLV</b> <b>OLV/PM</b> <b>AOLV/PM</b> <b>CLV/PM</b> <b>EZOLV</b></p> <p>Sets the input method for the analog reference used with AI-A3.</p> <p>0 : Individual input<br/>1 : 3 Channels Added Together</p>  | 0<br>(0, 1)                  | 333  |
| F2-02 (0368) RUN | Analog Input Option Card Gain   | <p><b>V/f</b> <b>CL-V/f</b> <b>OLV</b> <b>CLV</b> <b>AOLV</b> <b>OLV/PM</b> <b>AOLV/PM</b> <b>CLV/PM</b> <b>EZOLV</b></p> <p>Sets the analog reference gain as a percentage when the maximum output frequency is 100%.</p> <p><b>Note:</b></p> <ul style="list-style-type: none"> <li>Set F2-01 = 1 [Analog Input Function Selection = 3 Channels Added Together] to enable this function.</li> <li>Parameter A1-02 [Control Method Selection] selects which parameter is the maximum output frequency.<br/>-A1-02 ≠ 8 [EZOLV]: E1-04 [Maximum Output Frequency]<br/>-A1-02 = 8: E9-02 [Maximum Speed]</li> </ul> | 100.0%<br>(-999.9 - +999.9%) | 335  |
| F2-03 (0369) RUN | Analog Input Option Card Bias   | <p><b>V/f</b> <b>CL-V/f</b> <b>OLV</b> <b>CLV</b> <b>AOLV</b> <b>OLV/PM</b> <b>AOLV/PM</b> <b>CLV/PM</b> <b>EZOLV</b></p> <p>Sets the analog reference bias as a percentage when the maximum output frequency is 100%.</p> <p><b>Note:</b></p> <ul style="list-style-type: none"> <li>Set F2-01 = 1 [Analog Input Function Selection = 3 Channels Added Together] to enable this function.</li> <li>Parameter A1-02 [Control Method Selection] selects which parameter is the maximum output frequency.<br/>-A1-02 ≠ 8 [EZOLV]: E1-04 [Maximum Output Frequency]<br/>-A1-02 = 8: E9-02 [Maximum Speed]</li> </ul> | 0.0%<br>(-999.9 - +999.9%)   | 335  |

## ◆ F3: Digital Input Option

| No. (Hex.)   | Name                             | Description   | Default (Range) | Ref. |
|--------------|----------------------------------|---|-----------------|------|
| F3-01 (0390) | Digital Input Function Selection | <p><b>V/f</b> <b>CL-V/f</b> <b>OLV</b> <b>CLV</b> <b>AOLV</b> <b>OLV/PM</b> <b>AOLV/PM</b> <b>CLV/PM</b> <b>EZOLV</b></p> <p>Sets the data format of digital input signals. This parameter is enabled when o1-03 = 0 or 1 [Frequency Display Unit Selection = 0.01 Hz or 0.01% (100% = E1-04)].</p> <p><b>Note:</b><br/>If o1-03 = 2 or 3 [min<sup>-1</sup> (r/min) Units or User Units], the input signal will be BCD. The o1-03 value sets the setting units.</p> <p>0 : BCD, 1% units<br/>1 : BCD, 0.1% units<br/>2 : BCD, 0.01% units<br/>3 : BCD, 1 Hz units<br/>4 : BCD, 0.1 Hz units<br/>5 : BCD, 0.01 Hz units<br/>6 : BCD (5-digit), 0.02 Hz<br/>7 : Binary input<br/>8 : Multi-Function Digital Input</p> | 8<br>(0 - 8)    | 336  |
| F3-03 (03B9) | Digital Input Data Length Select | <p><b>V/f</b> <b>CL-V/f</b> <b>OLV</b> <b>CLV</b> <b>AOLV</b> <b>OLV/PM</b> <b>AOLV/PM</b> <b>CLV/PM</b> <b>EZOLV</b></p> <p>Sets the number of bits to set the frequency reference with DI-A3.</p> <p>0 : 8-bit<br/>1 : 12-bit<br/>2 : 16-bit</p>  | 2<br>(0 to 2)   | 336  |

## 1.9 F: Options

| No. (Hex.)          | Name                           | Description  | Default (Range) | Ref. |
|---------------------|--------------------------------|--|-----------------|------|
| F3-10 (0BE3) Expert | Terminal D0 Function Selection | <b>V/f</b> <b>CL-V/f</b> <b>OLV</b> <b>CLV</b> <b>AOLV</b> <b>OLV/PM</b> <b>AOLV/PM</b> <b>CLV/PM</b> <b>EZOLV</b><br>Sets the function for terminal D0 of the DI-A3 when F3-01 = 8 [Digital Input Function Selection = Multi-Function Digital Input]. | F<br>(1 - 19F)  | 337  |
| F3-11 (0BE4) Expert | Terminal D1 Function Selection | <b>V/f</b> <b>CL-V/f</b> <b>OLV</b> <b>CLV</b> <b>AOLV</b> <b>OLV/PM</b> <b>AOLV/PM</b> <b>CLV/PM</b> <b>EZOLV</b><br>Sets the function for terminal D1 of the DI-A3 when F3-01 = 8 [Digital Input Function Selection = Multi-Function Digital Input]. | F<br>(1 - 19F)  | 337  |
| F3-12 (0BE5) Expert | Terminal D2 Function Selection | <b>V/f</b> <b>CL-V/f</b> <b>OLV</b> <b>CLV</b> <b>AOLV</b> <b>OLV/PM</b> <b>AOLV/PM</b> <b>CLV/PM</b> <b>EZOLV</b><br>Sets the function for terminal D2 of the DI-A3 when F3-01 = 8 [Digital Input Function Selection = Multi-Function Digital Input]. | F<br>(1 - 19F)  | 338  |
| F3-13 (0BE6) Expert | Terminal D3 Function Selection | <b>V/f</b> <b>CL-V/f</b> <b>OLV</b> <b>CLV</b> <b>AOLV</b> <b>OLV/PM</b> <b>AOLV/PM</b> <b>CLV/PM</b> <b>EZOLV</b><br>Sets the function for terminal D3 of the DI-A3 when F3-01 = 8 [Digital Input Function Selection = Multi-Function Digital Input]. | F<br>(1 - 19F)  | 338  |
| F3-14 (0BE7) Expert | Terminal D4 Function Selection | <b>V/f</b> <b>CL-V/f</b> <b>OLV</b> <b>CLV</b> <b>AOLV</b> <b>OLV/PM</b> <b>AOLV/PM</b> <b>CLV/PM</b> <b>EZOLV</b><br>Sets the function for terminal D4 of the DI-A3 when F3-01 = 8 [Digital Input Function Selection = Multi-Function Digital Input]. | F<br>(1 - 19F)  | 338  |
| F3-15 (0BE8) Expert | Terminal D5 Function Selection | <b>V/f</b> <b>CL-V/f</b> <b>OLV</b> <b>CLV</b> <b>AOLV</b> <b>OLV/PM</b> <b>AOLV/PM</b> <b>CLV/PM</b> <b>EZOLV</b><br>Sets the function for terminal D5 of the DI-A3 when F3-01 = 8 [Digital Input Function Selection = Multi-Function Digital Input]. | F<br>(1 - 19F)  | 338  |
| F3-16 (0BE9) Expert | Terminal D6 Function Selection | <b>V/f</b> <b>CL-V/f</b> <b>OLV</b> <b>CLV</b> <b>AOLV</b> <b>OLV/PM</b> <b>AOLV/PM</b> <b>CLV/PM</b> <b>EZOLV</b><br>Sets the function for terminal D6 of the DI-A3 when F3-01 = 8 [Digital Input Function Selection = Multi-Function Digital Input]. | F<br>(1 - 19F)  | 338  |
| F3-17 (0BEA) Expert | Terminal D7 Function Selection | <b>V/f</b> <b>CL-V/f</b> <b>OLV</b> <b>CLV</b> <b>AOLV</b> <b>OLV/PM</b> <b>AOLV/PM</b> <b>CLV/PM</b> <b>EZOLV</b><br>Sets the function for terminal D7 of the DI-A3 when F3-01 = 8 [Digital Input Function Selection = Multi-Function Digital Input]. | F<br>(1 - 19F)  | 338  |
| F3-18 (0BEB) Expert | Terminal D8 Function Selection | <b>V/f</b> <b>CL-V/f</b> <b>OLV</b> <b>CLV</b> <b>AOLV</b> <b>OLV/PM</b> <b>AOLV/PM</b> <b>CLV/PM</b> <b>EZOLV</b><br>Sets the function for terminal D8 of the DI-A3 when F3-01 = 8 [Digital Input Function Selection = Multi-Function Digital Input]. | F<br>(1 - 19F)  | 338  |
| F3-19 (0BEC) Expert | Terminal D9 Function Selection | <b>V/f</b> <b>CL-V/f</b> <b>OLV</b> <b>CLV</b> <b>AOLV</b> <b>OLV/PM</b> <b>AOLV/PM</b> <b>CLV/PM</b> <b>EZOLV</b><br>Sets the function for terminal D9 of the DI-A3 when F3-01 = 8 [Digital Input Function Selection = Multi-Function Digital Input]. | F<br>(1 - 19F)  | 339  |
| F3-20 (0BED) Expert | Terminal DA Function Selection | <b>V/f</b> <b>CL-V/f</b> <b>OLV</b> <b>CLV</b> <b>AOLV</b> <b>OLV/PM</b> <b>AOLV/PM</b> <b>CLV/PM</b> <b>EZOLV</b><br>Sets the function for terminal DA of the DI-A3 when F3-01 = 8 [Digital Input Function Selection = Multi-Function Digital Input]. | F<br>(1 - 19F)  | 339  |
| F3-21 (0BEE) Expert | Terminal DB Function Selection | <b>V/f</b> <b>CL-V/f</b> <b>OLV</b> <b>CLV</b> <b>AOLV</b> <b>OLV/PM</b> <b>AOLV/PM</b> <b>CLV/PM</b> <b>EZOLV</b><br>Sets the function for terminal DB of the DI-A3 when F3-01 = 8 [Digital Input Function Selection = Multi-Function Digital Input]. | F<br>(1 - 19F)  | 339  |
| F3-22 (0BEF) Expert | Terminal DC Function Selection | <b>V/f</b> <b>CL-V/f</b> <b>OLV</b> <b>CLV</b> <b>AOLV</b> <b>OLV/PM</b> <b>AOLV/PM</b> <b>CLV/PM</b> <b>EZOLV</b><br>Sets the function for terminal DC of the DI-A3 when F3-01 = 8 [Digital Input Function Selection = Multi-Function Digital Input]. | F<br>(1 - 19F)  | 339  |
| F3-23 (0BF0) Expert | Terminal DD Function Selection | <b>V/f</b> <b>CL-V/f</b> <b>OLV</b> <b>CLV</b> <b>AOLV</b> <b>OLV/PM</b> <b>AOLV/PM</b> <b>CLV/PM</b> <b>EZOLV</b><br>Sets the function for terminal DD of the DI-A3 when F3-01 = 8 [Digital Input Function Selection = Multi-Function Digital Input]. | F<br>(1 - 19F)  | 339  |
| F3-24 (0BF1) Expert | Terminal DE Function Selection | <b>V/f</b> <b>CL-V/f</b> <b>OLV</b> <b>CLV</b> <b>AOLV</b> <b>OLV/PM</b> <b>AOLV/PM</b> <b>CLV/PM</b> <b>EZOLV</b><br>Sets the function for terminal DE of the DI-A3 when F3-01 = 8 [Digital Input Function Selection = Multi-Function Digital Input]. | F<br>(1 - 19F)  | 339  |
| F3-25 (0BF2) Expert | Terminal DF Function Selection | <b>V/f</b> <b>CL-V/f</b> <b>OLV</b> <b>CLV</b> <b>AOLV</b> <b>OLV/PM</b> <b>AOLV/PM</b> <b>CLV/PM</b> <b>EZOLV</b><br>Sets the function for terminal DF of the DI-A3 when F3-01 = 8 [Digital Input Function Selection = Multi-Function Digital Input]. | F<br>(1 - 19F)  | 339  |



## ◆ F4: Analog Output Option

| No. (Hex.)       | Name                           | Description   | Default (Range)              | Ref. |
|------------------|--------------------------------|---|------------------------------|------|
| F4-01 (0391)     | Terminal V1 Function Selection | <b>V/f</b> <b>CL-V/f</b> <b>OLV</b> <b>CLV</b> <b>AOLV</b> <b>OLV/PM</b> <b>AOLV/PM</b> <b>CLV/PM</b> <b>EZOLV</b><br>Sets the monitor signal output from terminal V1.<br>Set the <i>x-xx</i> part of the <i>Ux-xx</i> [Monitor]. For example, set <i>F4-01 = 102</i> to monitor <i>U1-02</i> [Output Frequency].                             | 102<br>(000 - 999)           | 340  |
| F4-02 (0392) RUN | Terminal V1 Gain               | <b>V/f</b> <b>CL-V/f</b> <b>OLV</b> <b>CLV</b> <b>AOLV</b> <b>OLV/PM</b> <b>AOLV/PM</b> <b>CLV/PM</b> <b>EZOLV</b><br>Sets the gain of the monitor signal that is sent from terminal V1. Sets the analog signal output level from the terminal V1 at 10 V or 20 mA as 100% when an output for monitoring items is 100%.                       | 100.0%<br>(-999.9 - +999.9%) | 340  |
| F4-03 (0393)     | Terminal V2 Function Selection | <b>V/f</b> <b>CL-V/f</b> <b>OLV</b> <b>CLV</b> <b>AOLV</b> <b>OLV/PM</b> <b>AOLV/PM</b> <b>CLV/PM</b> <b>EZOLV</b><br>Sets the monitor signal output from terminal V2.<br>Set the <i>x-xx</i> part of the <i>Ux-xx</i> [Monitor]. For example, set <i>F4-03 = 103</i> to monitor <i>U1-03</i> [Output Current].                               | 103<br>(000 - 999)           | 341  |
| F4-04 (0394) RUN | Terminal V2 Gain               | <b>V/f</b> <b>CL-V/f</b> <b>OLV</b> <b>CLV</b> <b>AOLV</b> <b>OLV/PM</b> <b>AOLV/PM</b> <b>CLV/PM</b> <b>EZOLV</b><br>Sets the gain of the monitor signal that is sent from terminal V2. Sets the analog signal output level from the terminal V2 at 10 V or 20 mA as 100% when an output for monitoring items is 100%.                       | 50.0%<br>(-999.9 - +999.9%)  | 341  |
| F4-05 (0395) RUN | Terminal V1 Bias               | <b>V/f</b> <b>CL-V/f</b> <b>OLV</b> <b>CLV</b> <b>AOLV</b> <b>OLV/PM</b> <b>AOLV/PM</b> <b>CLV/PM</b> <b>EZOLV</b><br>Sets the bias of the monitor signal that is sent from terminal V1. When an output for monitoring items is 0%, this parameter sets the analog signal output level from the V1 terminal as a percentage of 10 V or 20 mA. | 0.0%<br>(-999.9 - +999.9%)   | 341  |
| F4-06 (0396) RUN | Terminal V2 Bias               | <b>V/f</b> <b>CL-V/f</b> <b>OLV</b> <b>CLV</b> <b>AOLV</b> <b>OLV/PM</b> <b>AOLV/PM</b> <b>CLV/PM</b> <b>EZOLV</b><br>Sets the bias of the monitor signal that is sent from terminal V2. Set the level of the analog signal sent from the V2 terminal at 10 V or 20 mA as 100% when an output for monitoring items is 0%.                     | 0.0%<br>(-999.9 - +999.9%)   | 341  |
| F4-07 (0397)     | Terminal V1 Signal Level       | <b>V/f</b> <b>CL-V/f</b> <b>OLV</b> <b>CLV</b> <b>AOLV</b> <b>OLV/PM</b> <b>AOLV/PM</b> <b>CLV/PM</b> <b>EZOLV</b><br>Sets the output signal level for terminal V1.<br>0 : 0 to 10 V<br>1 : -10 to +10V (Bipolar Reference)   | 0<br>(0, 1)                  | 342  |
| F4-08 (0398)     | Terminal V2 Signal Level       | <b>V/f</b> <b>CL-V/f</b> <b>OLV</b> <b>CLV</b> <b>AOLV</b> <b>OLV/PM</b> <b>AOLV/PM</b> <b>CLV/PM</b> <b>EZOLV</b><br>Sets the output signal level for terminal V2.<br>0 : 0 to 10 V<br>1 : -10 to +10V (Bipolar Reference)   | 0<br>(0, 1)                  | 342  |

## ◆ F5: Digital Output Option

| No. (Hex.)   | Name                           | Description  | Default (Range) | Ref. |
|--------------|--------------------------------|--|-----------------|------|
| F5-01 (0399) | Terminal P1-PC Function Select | <b>V/f</b> <b>CL-V/f</b> <b>OLV</b> <b>CLV</b> <b>AOLV</b> <b>OLV/PM</b> <b>AOLV/PM</b> <b>CLV/PM</b> <b>EZOLV</b><br>Sets the function of terminal P1-PC on the DO-A3 option. Set <i>F5-09 = 2</i> [DO-A3 Output Mode Selection = Programmable (F5-01 to F5-08)] to enable this function. | 0<br>(0 - 1A7)  | 343  |
| F5-02 (039A) | Terminal P2-PC Function Select | <b>V/f</b> <b>CL-V/f</b> <b>OLV</b> <b>CLV</b> <b>AOLV</b> <b>OLV/PM</b> <b>AOLV/PM</b> <b>CLV/PM</b> <b>EZOLV</b><br>Sets the function of terminal P2-PC on the DO-A3 option. Set <i>F5-09 = 2</i> [DO-A3 Output Mode Selection = Programmable (F5-01 to F5-08)] to enable this function. | 1<br>(0 - 1A7)  | 343  |
| F5-03 (039B) | Terminal P3-PC Function Select | <b>V/f</b> <b>CL-V/f</b> <b>OLV</b> <b>CLV</b> <b>AOLV</b> <b>OLV/PM</b> <b>AOLV/PM</b> <b>CLV/PM</b> <b>EZOLV</b><br>Sets the function of terminal P3-PC on the DO-A3 option. Set <i>F5-09 = 2</i> [DO-A3 Output Mode Selection = Programmable (F5-01 to F5-08)] to enable this function. | 2<br>(0 - 1A7)  | 344  |
| F5-04 (039C) | Terminal P4-PC Function Select | <b>V/f</b> <b>CL-V/f</b> <b>OLV</b> <b>CLV</b> <b>AOLV</b> <b>OLV/PM</b> <b>AOLV/PM</b> <b>CLV/PM</b> <b>EZOLV</b><br>Sets the function of terminal P4-PC on the DO-A3 option. Set <i>F5-09 = 2</i> [DO-A3 Output Mode Selection = Programmable (F5-01 to F5-08)] to enable this function. | 4<br>(0 - 1A7)  | 344  |
| F5-05 (039D) | Terminal P5-PC Function Select | <b>V/f</b> <b>CL-V/f</b> <b>OLV</b> <b>CLV</b> <b>AOLV</b> <b>OLV/PM</b> <b>AOLV/PM</b> <b>CLV/PM</b> <b>EZOLV</b><br>Sets the function of terminal P5-PC on the DO-A3 option. Set <i>F5-09 = 2</i> [DO-A3 Output Mode Selection = Programmable (F5-01 to F5-08)] to enable this function. | 6<br>(0 - 1A7)  | 344  |
| F5-06 (039E) | Terminal P6-PC Function Select | <b>V/f</b> <b>CL-V/f</b> <b>OLV</b> <b>CLV</b> <b>AOLV</b> <b>OLV/PM</b> <b>AOLV/PM</b> <b>CLV/PM</b> <b>EZOLV</b><br>Sets the function of terminal P6-PC on the DO-A3 option. Set <i>F5-09 = 2</i> [DO-A3 Output Mode Selection = Programmable (F5-01 to F5-08)] to enable this function. | 37<br>(0 - 1A7) | 344  |
| F5-07 (039F) | Terminal M1-M2 Function Select | <b>V/f</b> <b>CL-V/f</b> <b>OLV</b> <b>CLV</b> <b>AOLV</b> <b>OLV/PM</b> <b>AOLV/PM</b> <b>CLV/PM</b> <b>EZOLV</b><br>Sets the function of terminal M3-M2 on the DO-A3 option. Set <i>F5-09 = 2</i> [DO-A3 Output Mode Selection = Programmable (F5-01 to F5-08)] to enable this function. | F<br>(0 - 1A7)  | 344  |

## 1.9 F: Options

| No. (Hex.)   | Name                           | Description  | Default (Range) | Ref. |
|--------------|--------------------------------|--|-----------------|------|
| F5-08 (03A0) | Terminal M3-M4 Function Select | <b>V/f</b> <b>CL-V/f</b> <b>OLV</b> <b>CLV</b> <b>AOLV</b> <b>OLV/PM</b> <b>AOLV/PM</b> <b>CLV/PM</b> <b>EZOLV</b><br>Sets the function of terminal M3-M4 on the DO-A3 option. Set <i>F5-09 = 2 [DO-A3 Output Mode Selection = Programmable (F5-01 to F5-08)]</i> to enable this function. | F<br>(0 - 1A7)  | 344  |
| F5-09 (03A1) | DO-A3 Output Mode Selection    | <b>V/f</b> <b>CL-V/f</b> <b>OLV</b> <b>CLV</b> <b>AOLV</b> <b>OLV/PM</b> <b>AOLV/PM</b> <b>CLV/PM</b> <b>EZOLV</b><br>Sets the output mode of signals from the DO-A3 option.<br>0 : Predefined Individual Outputs<br>1 : Binary Output<br>2 : Programmable (F5-01 to F5-08)                | 0<br>(0 - 2)    | 344  |

### ◆ F6: Communication Options

| No. (Hex.)   | Name                             | Description  | Default (Range)        | Ref. |
|--------------|----------------------------------|--|------------------------|------|
| F6-01 (03A2) | Communication Error Selection    | <b>V/f</b> <b>CL-V/f</b> <b>OLV</b> <b>CLV</b> <b>AOLV</b> <b>OLV/PM</b> <b>AOLV/PM</b> <b>CLV/PM</b> <b>EZOLV</b><br>Sets the method to stop the motor or let the motor continue operating when the drive detects a <i>bUS [Option Communication Error]</i> .<br>0 : Ramp to Stop<br>1 : Coast to Stop<br>2 : Fast Stop<br>3 : Alarm Only<br>4 : Alarm (Run at d1-04)<br>5 : Alarm - Ramp Stop  | 1<br>(0 - 5)           | 350  |
| F6-02 (03A3) | Comm External Fault (EF0) Detect | <b>V/f</b> <b>CL-V/f</b> <b>OLV</b> <b>CLV</b> <b>AOLV</b> <b>OLV/PM</b> <b>AOLV/PM</b> <b>CLV/PM</b> <b>EZOLV</b><br>Sets the conditions at which <i>EF0 [Option Card External Fault]</i> is detected.<br>0 : Detection Always Enabled<br>1 : Detected during RUN Only  | 0<br>(0, 1)            | 351  |
| F6-03 (03A4) | Comm External Fault (EF0) Select | <b>V/f</b> <b>CL-V/f</b> <b>OLV</b> <b>CLV</b> <b>AOLV</b> <b>OLV/PM</b> <b>AOLV/PM</b> <b>CLV/PM</b> <b>EZOLV</b><br>Sets the method to stop the motor or let the motor continue operating when the drive detects an <i>EF0 [Option Card External Fault]</i> .<br>0 : Ramp to Stop<br>1 : Coast to Stop<br>2 : Fast Stop<br>3 : Continue operation (alarm only)   | 1<br>(0 - 3)           | 351  |
| F6-04 (03A5) | bUS Error Detection Time         | <b>V/f</b> <b>CL-V/f</b> <b>OLV</b> <b>CLV</b> <b>AOLV</b> <b>OLV/PM</b> <b>AOLV/PM</b> <b>CLV/PM</b> <b>EZOLV</b><br>Sets the delay time for the drive to detect <i>bUS [Option Communication Error]</i> .<br><b>Note:</b><br>When you install an option card in the drive, the parameter value changes to 0.0 s.   | 2.0 s<br>(0.0 - 5.0 s) | 351  |
| F6-06 (03A7) | Torque Reference/Limit by Comm   | <b>V/f</b> <b>CL-V/f</b> <b>OLV</b> <b>CLV</b> <b>AOLV</b> <b>OLV/PM</b> <b>AOLV/PM</b> <b>CLV/PM</b> <b>EZOLV</b><br>Sets the function that enables and disables the torque reference and torque limit received from the communication option.<br>0 : No<br>1 : Yes   | 0<br>(0, 1)            | 351  |
| F6-07 (03A8) | Multi-Step Ref @ NetRef/ComRef   | <b>V/f</b> <b>CL-V/f</b> <b>OLV</b> <b>CLV</b> <b>AOLV</b> <b>OLV/PM</b> <b>AOLV/PM</b> <b>CLV/PM</b> <b>EZOLV</b><br>Sets the function that enables and disables the multi-step speed reference when the frequency reference source is NetRef or ComRef (communication option card or MEMOBUS/Modbus communications).<br>0 : Disable Multi-Step References<br>1 : Enable Multi-Step References  | 0<br>(0, 1)            | 352  |
| F6-08 (036A) | Comm Parameter Reset @Initialize | <b>V/f</b> <b>CL-V/f</b> <b>OLV</b> <b>CLV</b> <b>AOLV</b> <b>OLV/PM</b> <b>AOLV/PM</b> <b>CLV/PM</b> <b>EZOLV</b><br>Sets the function to initialize <i>F6-xx</i> and <i>F7-xx</i> parameters when the drive is initialized with <i>A1-03 [Initialize Parameters]</i> .<br>0 : No Reset - Parameters Retained<br>1 : Reset Back to Factory Default  | 0<br>(0, 1)            | 352  |
| F6-10 (03B6) | CC-Link Node Address             | <b>V/f</b> <b>CL-V/f</b> <b>OLV</b> <b>CLV</b> <b>AOLV</b> <b>OLV/PM</b> <b>AOLV/PM</b> <b>CLV/PM</b> <b>EZOLV</b><br>Sets the node address for CC-Link communication. Restart the drive after changing the parameter setting.<br><b>Note:</b><br>Be sure to set a node address that is different than all other node addresses. Do not set this parameter to 0. Incorrect parameter settings will cause <i>AEr [Station Address Setting Error]</i> errors and the L.ERR LED on the option will come on. | 0<br>(0 - 64)          | 352  |

| No. (Hex.)   | Name                                  | Description  | Default (Range)  | Ref. |
|--------------|---------------------------------------|--|--|------|
| F6-11 (03B7) | CC-Link Communication Speed           | <b>V/f</b> <b>CL-V/f</b> <b>OLV</b> <b>CLV</b> <b>AOLV</b> <b>OLV/PM</b> <b>AOLV/PM</b> <b>CLV/PM</b> <b>EZOLV</b><br>Sets the communication speed for CC-Link communication. Restart the drive after changing the parameter setting.<br>0 : 156 kbps<br>1 : 625 kbps<br>2 : 2.5 Mbps<br>3 : 5 Mbps<br>4 : 10 Mbps   | 0<br>(0 - 4)   | 352  |
| F6-14 (03BB) | BUS Error Auto Reset                  | <b>V/f</b> <b>CL-V/f</b> <b>OLV</b> <b>CLV</b> <b>AOLV</b> <b>OLV/PM</b> <b>AOLV/PM</b> <b>CLV/PM</b> <b>EZOLV</b><br>Sets the automatic reset function for <i>bUS</i> [Option Communication Errors].<br>0 : No<br>1 : Yes   | 0<br>(0, 1)  | 353  |
| F6-15 (0B5B) | Communication Option Parameter Reload | <b>V/f</b> <b>CL-V/f</b> <b>OLV</b> <b>CLV</b> <b>AOLV</b> <b>OLV/PM</b> <b>AOLV/PM</b> <b>CLV/PM</b> <b>EZOLV</b><br>Sets the update method when F6-xx, F7-xx [Communication Options] are changed.<br>0 : It is updated when the power turns on again.<br>1 : Update immediately<br>2 : Cancel update   | 0<br>(0 - 2)   | 353  |
| F6-16 (0B8A) | Gateway Mode                          | <b>V/f</b> <b>CL-V/f</b> <b>OLV</b> <b>CLV</b> <b>AOLV</b> <b>OLV/PM</b> <b>AOLV/PM</b> <b>CLV/PM</b> <b>EZOLV</b><br>Sets the gateway mode operation and the number of connected slave drives.<br>0 : Disabled<br>1 : Enabled: 1 Slave Drives<br>2 : Enabled: 2 Slave Drives<br>3 : Enabled: 3 Slave Drives<br>4 : Enabled: 4 Slave Drives  | 0<br>(0 to 4)  | 353  |
| F6-20 (036B) | MECHATROLINK Station Address          | <b>V/f</b> <b>CL-V/f</b> <b>OLV</b> <b>CLV</b> <b>AOLV</b> <b>OLV/PM</b> <b>AOLV/PM</b> <b>CLV/PM</b> <b>EZOLV</b><br>Sets the station address for MECHATROLINK communication. Restart the drive after changing the parameter setting.<br><b>Note:</b><br>• The setting range changes if using MECHATROLINK-II or MECHATROLINK-III:<br>–MECHATROLINK-II (SI-T3) range: 20 - 3F<br>–MECHATROLINK-III (SI-ET3) range: 03 - EF<br>• Be sure to set a node address that is different than all other node addresses. Incorrect parameter settings will cause <i>AEr</i> [Station Address Setting Error] errors and the L. ERR LED on the option will come on.<br>• When the station address is 20 or 3F, the drive detects <i>AEr v</i> errors. | 0021h<br>(MECHATROLINK-II: 0020h - 003Fh, MECHATROLINK-III: 0003h - 00EFh) | 353  |
| F6-21 (036C) | MECHATROLINK Frame Size               | <b>V/f</b> <b>CL-V/f</b> <b>OLV</b> <b>CLV</b> <b>AOLV</b> <b>OLV/PM</b> <b>AOLV/PM</b> <b>CLV/PM</b> <b>EZOLV</b><br>Sets the frame size for MECHATROLINK communication. Restart the drive after changing the parameter setting.<br>0 : 32byte (M-2) / 64byte (M-3)<br>1 : 17byte (M-2) / 32byte (M-3)  | 0<br>(0, 1)  | 354  |
| F6-22 (036D) | MECHATROLINK Link Speed               | <b>V/f</b> <b>CL-V/f</b> <b>OLV</b> <b>CLV</b> <b>AOLV</b> <b>OLV/PM</b> <b>AOLV/PM</b> <b>CLV/PM</b> <b>EZOLV</b><br>Sets the communications speed for MECHATROLINK-II. Restart the drive after changing the parameter setting.<br><b>Note:</b><br>This parameter is only available with the MECHATROLINK-II option.<br>0 : 10 Mbps<br>1 : 4 Mbps   | 0<br>(0, 1)  | 354  |
| F6-23 (036E) | MECHATROLINK Monitor Select (E)       | <b>V/f</b> <b>CL-V/f</b> <b>OLV</b> <b>CLV</b> <b>AOLV</b> <b>OLV/PM</b> <b>AOLV/PM</b> <b>CLV/PM</b> <b>EZOLV</b><br>Sets the MEMOBUS register used for the monitor functions of INV_CTL (drive operation control command) and INV_I/O (drive I/O control command). Restart the drive after changing the parameter setting.   | 0000h<br>(0000h - FFFFh)   | 354  |
| F6-24 (036F) | MECHATROLINK Monitor Select (F)       | <b>V/f</b> <b>CL-V/f</b> <b>OLV</b> <b>CLV</b> <b>AOLV</b> <b>OLV/PM</b> <b>AOLV/PM</b> <b>CLV/PM</b> <b>EZOLV</b><br>Sets the MEMOBUS register used for the monitor functions of INV_CTL (drive operation control command) and INV_I/O (drive I/O control command). Restart the drive after changing the parameter setting.   | 0000h<br>(0000h - FFFFh)   | 354  |
| F6-25 (03C9) | MECHATROLINK Watchdog Error Sel       | <b>V/f</b> <b>CL-V/f</b> <b>OLV</b> <b>CLV</b> <b>AOLV</b> <b>OLV/PM</b> <b>AOLV/PM</b> <b>CLV/PM</b> <b>EZOLV</b><br>Sets the method to stop the motor or let the motor continue operating when the drive detects an <i>E5</i> [MECHATROLINK Watchdog Timer Err].<br>0 : Ramp to Stop<br>1 : Coast to Stop<br>2 : Fast Stop<br>3 : Continue operation (alarm only)  | 1<br>(0 - 3)   | 354  |
| F6-26 (03CA) | MECHATROLINK Allowable No of Err      | <b>V/f</b> <b>CL-V/f</b> <b>OLV</b> <b>CLV</b> <b>AOLV</b> <b>OLV/PM</b> <b>AOLV/PM</b> <b>CLV/PM</b> <b>EZOLV</b><br>Sets the number of times that the option must detect a <i>bUS</i> alarm to cause a <i>bUS</i> [Option Communication Error].  | 2<br>(2 - 10 times)  | 355  |

## 1.9 F: Options

| No. (Hex.)   | Name                             | Description  | Default (Range)     | Ref. |
|--------------|----------------------------------|--|---------------------|------|
| F6-30 (03CB) | PROFIBUS-DP Node Address         | <p><b>V/f</b> <b>CL-V/f</b> <b>OLV</b> <b>CLV</b> <b>AOLV</b> <b>OLV/PM</b> <b>AOLV/PM</b> <b>CLV/PM</b> <b>EZOLV</b></p> <p>Sets the node address for PROFIBUS-DP communication. Restart the drive after changing the parameter setting.</p> <p><b>Note:</b><br/>Be sure to set an address that is different than all other node addresses. Do not set this parameter to 0.</p>   | 0<br>(0 - 125)      | 355  |
| F6-31 (03CC) | PROFIBUS-DP Clear Mode Selection | <p><b>V/f</b> <b>CL-V/f</b> <b>OLV</b> <b>CLV</b> <b>AOLV</b> <b>OLV/PM</b> <b>AOLV/PM</b> <b>CLV/PM</b> <b>EZOLV</b></p> <p>Sets what the drive will do after it receives the Clear Mode command.</p> <p>0 : Reset<br/>1 : Hold Previous State</p>  | 0<br>(0, 1)         | 355  |
| F6-32 (03CD) | PROFIBUS-DP Data Format Select   | <p><b>V/f</b> <b>CL-V/f</b> <b>OLV</b> <b>CLV</b> <b>AOLV</b> <b>OLV/PM</b> <b>AOLV/PM</b> <b>CLV/PM</b> <b>EZOLV</b></p> <p>Sets the data format of PROFIBUS-DP communication. Restart the drive after changing the parameter setting.</p> <p>0 : PPO Type<br/>1 : Conventional<br/>2 : PPO (bit0)<br/>3 : PPO (Enter)<br/>4 : Conventional (Enter)<br/>5 : PPO (bit0, Enter)</p>   | 0<br>(0 - 5)        | 355  |
| F6-35 (03D0) | CANopen Node ID Selection        | <p><b>V/f</b> <b>CL-V/f</b> <b>OLV</b> <b>CLV</b> <b>AOLV</b> <b>OLV/PM</b> <b>AOLV/PM</b> <b>CLV/PM</b> <b>EZOLV</b></p> <p>Sets the node address for CANopen communication. Restart the drive after changing the parameter setting.</p> <p><b>Note:</b><br/>Be sure to set an address that is different than all other node addresses. Do not set this parameter to 0. Incorrect parameter settings will cause <i>AEr [Station Address Setting Error]</i> errors and the L.ERR LED on the option will come on.</p> | 0<br>(0 - 126)      | 356  |
| F6-36 (03D1) | CANopen Communication Speed      | <p><b>V/f</b> <b>CL-V/f</b> <b>OLV</b> <b>CLV</b> <b>AOLV</b> <b>OLV/PM</b> <b>AOLV/PM</b> <b>CLV/PM</b> <b>EZOLV</b></p> <p>Sets the CANopen communications speed. Restart the drive after changing the parameter setting.</p> <p>0 : Detect Automatically<br/>1 : 10 kbps<br/>2 : 20 kbps<br/>3 : 50 kbps<br/>4 : 125 kbps<br/>5 : 250 kbps<br/>6 : 500 kbps<br/>7 : 800 kbps<br/>8 : 1 Mbps</p>   | 6<br>(0 - 8)        | 356  |
| F6-45 (02FB) | BACnet Node Address              | <p><b>V/f</b> <b>CL-V/f</b> <b>OLV</b> <b>CLV</b> <b>AOLV</b> <b>OLV/PM</b> <b>AOLV/PM</b> <b>CLV/PM</b> <b>EZOLV</b></p> <p>Sets the node address for BACnet communication.</p> <p><b>Note:</b><br/>Be sure to set an address that is different than all other node addresses. Do not set this parameter to 0.</p>  | 1<br>(0 - 127)      | 356  |
| F6-46 (02FC) | BACnet Baud Rate                 | <p><b>V/f</b> <b>CL-V/f</b> <b>OLV</b> <b>CLV</b> <b>AOLV</b> <b>OLV/PM</b> <b>AOLV/PM</b> <b>CLV/PM</b> <b>EZOLV</b></p> <p>Sets the BACnet communications speed.</p> <p>0 : 1200 bps<br/>1 : 2400 bps<br/>2 : 4800 bps<br/>3 : 9600 bps<br/>4 : 19.2 kbps<br/>5 : 38.4 kbps<br/>6 : 57.6 kbps<br/>7 : 76.8 kbps<br/>8 : 115.2 kbps</p>   | 3<br>(0 - 8)        | 356  |
| F6-47 (02FD) | Rx to Tx Wait Time               | <p><b>V/f</b> <b>CL-V/f</b> <b>OLV</b> <b>CLV</b> <b>AOLV</b> <b>OLV/PM</b> <b>AOLV/PM</b> <b>CLV/PM</b> <b>EZOLV</b></p> <p>Sets the wait time for the drive to receive and send BACnet communication.</p>  | 5 ms<br>(5 - 65 ms) | 357  |
| F6-48 (02FE) | BACnet Device Object Identifier0 | <p><b>V/f</b> <b>CL-V/f</b> <b>OLV</b> <b>CLV</b> <b>AOLV</b> <b>OLV/PM</b> <b>AOLV/PM</b> <b>CLV/PM</b> <b>EZOLV</b></p> <p>Sets the last word of BACnet communication addresses.</p>   | 0<br>(0 - FFFF)     | 357  |
| F6-49 (02FF) | BACnet Device Object Identifier1 | <p><b>V/f</b> <b>CL-V/f</b> <b>OLV</b> <b>CLV</b> <b>AOLV</b> <b>OLV/PM</b> <b>AOLV/PM</b> <b>CLV/PM</b> <b>EZOLV</b></p> <p>Sets the last word of BACnet communication addresses.</p>   | 0<br>(0 - 3F)       | 357  |

| No. (Hex.)                                  | Name                                  | Description   | Default (Range)          | Ref. |
|---|---------------------------------------|---|--------------------------|------|
| F6-50 (03C1)                                | DeviceNet MAC Address                 | <b>V/f</b> <b>CL-V/f</b> <b>OLV</b> <b>CLV</b> <b>AOLV</b> <b>OLV/PM</b> <b>AOLV/PM</b> <b>CLV/PM</b> <b>EZOLV</b><br>Sets the MAC address for DeviceNet communication. Restart the drive after changing the parameter setting.<br><b>Note:</b><br>Be sure to set a MAC address that is different than all other node addresses. Do not set this parameter to 0. Incorrect parameter settings will cause <i>AEr [Station Address Setting Error]</i> errors and the MS LED on the option will flash. | 64<br>(0 - 64)           | 357  |
| F6-51 (03C2)                                | DeviceNet Baud Rate                   | <b>V/f</b> <b>CL-V/f</b> <b>OLV</b> <b>CLV</b> <b>AOLV</b> <b>OLV/PM</b> <b>AOLV/PM</b> <b>CLV/PM</b> <b>EZOLV</b><br>Sets the DeviceNet communications speed. Restart the drive after changing the parameter setting.<br>0 : 125 kbps<br>1 : 250 kbps<br>2 : 500 kbps<br>3 : Adjustable from Network<br>4 : Detect Automatically   | 4<br>(0 - 4)             | 357  |
| F6-52 (03C3)                                | DeviceNet PCA Setting                 | <b>V/f</b> <b>CL-V/f</b> <b>OLV</b> <b>CLV</b> <b>AOLV</b> <b>OLV/PM</b> <b>AOLV/PM</b> <b>CLV/PM</b> <b>EZOLV</b><br>Sets the format of data that the DeviceNet communication master sends to the drive.   | 21<br>(0 - 255)          | 357  |
| F6-53 (03C4)                                | DeviceNet PPA Setting                 | <b>V/f</b> <b>CL-V/f</b> <b>OLV</b> <b>CLV</b> <b>AOLV</b> <b>OLV/PM</b> <b>AOLV/PM</b> <b>CLV/PM</b> <b>EZOLV</b><br>Sets the format of data that the drive sends to the DeviceNet communication master.   | 71<br>(0 - 255)          | 358  |
| F6-54 (03C5)                                | DeviceNet Idle Fault Detection        | <b>V/f</b> <b>CL-V/f</b> <b>OLV</b> <b>CLV</b> <b>AOLV</b> <b>OLV/PM</b> <b>AOLV/PM</b> <b>CLV/PM</b> <b>EZOLV</b><br>Sets the function to detect <i>EF0 [Option Card External Fault]</i> when the drive does not receive data from the DeviceNet master.<br>0 : Enabled<br>1 : Disabled, No Fault Detection<br>2 : Vendor Specific<br>3 : Forward run<br>4 : Reverse run   | 0<br>(0 - 4)             | 358  |
| F6-55 (03C6)                                | DeviceNet Baud Rate Monitor           | <b>V/f</b> <b>CL-V/f</b> <b>OLV</b> <b>CLV</b> <b>AOLV</b> <b>OLV/PM</b> <b>AOLV/PM</b> <b>CLV/PM</b> <b>EZOLV</b><br>Sets the function to see the actual DeviceNet communications speed using the keypad. This parameter functions as a monitor only.<br>0 : 125 kbps<br>1 : 250 kbps<br>2 : 500 kbps  | 0<br>(0 - 2)             | 358  |
| F6-56 (03D7)                                | DeviceNet Speed Scaling               | <b>V/f</b> <b>CL-V/f</b> <b>OLV</b> <b>CLV</b> <b>AOLV</b> <b>OLV/PM</b> <b>AOLV/PM</b> <b>CLV/PM</b> <b>EZOLV</b><br>Sets the speed scale for DeviceNet communication.   | 0<br>(-15 - +15)         | 358  |
| F6-57 (03D8)                                | DeviceNet Current Scaling             | <b>V/f</b> <b>CL-V/f</b> <b>OLV</b> <b>CLV</b> <b>AOLV</b> <b>OLV/PM</b> <b>AOLV/PM</b> <b>CLV/PM</b> <b>EZOLV</b><br>Sets the current scale of the DeviceNet communication master.   | 0<br>(-15 - +15)         | 358  |
| F6-58 (03D9)                                | DeviceNet Torque Scaling              | <b>V/f</b> <b>CL-V/f</b> <b>OLV</b> <b>CLV</b> <b>AOLV</b> <b>OLV/PM</b> <b>AOLV/PM</b> <b>CLV/PM</b> <b>EZOLV</b><br>Sets the torque scale of the DeviceNet communication master.  | 0<br>(-15 - +15)         | 358  |
| F6-59 (03DA)                                | DeviceNet Power Scaling               | <b>V/f</b> <b>CL-V/f</b> <b>OLV</b> <b>CLV</b> <b>AOLV</b> <b>OLV/PM</b> <b>AOLV/PM</b> <b>CLV/PM</b> <b>EZOLV</b><br>Sets the power scale of the DeviceNet communication master.   | 0<br>(-15 - +15)         | 359  |
| F6-60 (03DB)                                | DeviceNet Voltage Scaling             | <b>V/f</b> <b>CL-V/f</b> <b>OLV</b> <b>CLV</b> <b>AOLV</b> <b>OLV/PM</b> <b>AOLV/PM</b> <b>CLV/PM</b> <b>EZOLV</b><br>Sets the voltage scale of the DeviceNet communication master.   | 0<br>(-15 - +15)         | 359  |
| F6-61 (03DC)                                | DeviceNet Time Scaling                | <b>V/f</b> <b>CL-V/f</b> <b>OLV</b> <b>CLV</b> <b>AOLV</b> <b>OLV/PM</b> <b>AOLV/PM</b> <b>CLV/PM</b> <b>EZOLV</b><br>Sets the time scale of the DeviceNet communication master.  | 0<br>(-15 - +15)         | 359  |
| F6-62 (03DD)                                | DeviceNet Heartbeat Interval          | <b>V/f</b> <b>CL-V/f</b> <b>OLV</b> <b>CLV</b> <b>AOLV</b> <b>OLV/PM</b> <b>AOLV/PM</b> <b>CLV/PM</b> <b>EZOLV</b><br>Sets the heartbeat for DeviceNet communication. Set this parameter to 0 to disable the heartbeat function.  | 0<br>(0 - 10)            | 359  |
| F6-63 (03DE)                                | DeviceNet Network MAC ID              | <b>V/f</b> <b>CL-V/f</b> <b>OLV</b> <b>CLV</b> <b>AOLV</b> <b>OLV/PM</b> <b>AOLV/PM</b> <b>CLV/PM</b> <b>EZOLV</b><br>Sets the function to see the actual DeviceNet MAC address using the keypad. This parameter functions as a monitor only.   | 63<br>(0 - 63)           | 359  |
| F6-64 to F6-67 (03DF - 03E2)                | Dynamic Out Assembly 109 Param 1 to 4 | <b>V/f</b> <b>CL-V/f</b> <b>OLV</b> <b>CLV</b> <b>AOLV</b> <b>OLV/PM</b> <b>AOLV/PM</b> <b>CLV/PM</b> <b>EZOLV</b><br>Sets Configurable Outputs 1 to 4 written to the MEMOBUS register.   | 0000h<br>(0000h - FFFFh) | 359  |
| F6-68 to F6-71 (03E3, 03E4, 03C7, and 03C8) | Dynamic In Assembly 159 Param 1 to 4  | <b>V/f</b> <b>CL-V/f</b> <b>OLV</b> <b>CLV</b> <b>AOLV</b> <b>OLV/PM</b> <b>AOLV/PM</b> <b>CLV/PM</b> <b>EZOLV</b><br>Sets Configurable Inputs 1 to 4 written to the MEMOBUS register.  | 0000h<br>(0000h - FFFFh) | 359  |
| F6-72 (081B)                                | PowerLink Node Address                | <b>V/f</b> <b>CL-V/f</b> <b>OLV</b> <b>CLV</b> <b>AOLV</b> <b>OLV/PM</b> <b>AOLV/PM</b> <b>CLV/PM</b> <b>EZOLV</b><br>Sets the node ID for PowerLink communication.<br><b>Note:</b><br>Be sure to set an address that is different than all other node addresses. Do not set this parameter to 0.   | 0<br>(0 - 255)           | 359  |

◆ F7: Ethernet Options

| No. (Hex.)   | Name              | Description   | Default (Range)  | Ref. |
|--------------|-------------------|---|------------------|------|
| F7-01 (03E5) | IP Address 1      | <p><b>V/f</b> <b>CL-V/f</b> <b>OLV</b> <b>CLV</b> <b>AOLV</b> <b>OLV/PM</b> <b>AOLV/PM</b> <b>CLV/PM</b> <b>EZOLV</b></p> <p>Sets the first octet of the IP Address for the device that is connecting to the network. Restart the drive after you change this parameter.</p> <p><b>Note:</b><br/>When <i>F7-13 = 0</i> [<i>Address Mode at Startup = Static</i>]:<br/> <ul style="list-style-type: none"> <li>Use parameters <i>F7-01</i> to <i>F7-04</i> [<i>IP Address 4</i>] to set the IP Address. Be sure to set a different IP address for each drive on the network.</li> <li>Also set parameters <i>F7-01</i> to <i>F7-12</i>.</li> </ul> </p>  | 192<br>(0 - 255) | 360  |
| F7-02 (03E6) | IP Address 2      | <p><b>V/f</b> <b>CL-V/f</b> <b>OLV</b> <b>CLV</b> <b>AOLV</b> <b>OLV/PM</b> <b>AOLV/PM</b> <b>CLV/PM</b> <b>EZOLV</b></p> <p>Sets the second octet of the IP Address for the device that is connecting to the network. Restart the drive after you change this parameter.</p> <p><b>Note:</b><br/>When <i>F7-13 = 0</i> [<i>Address Mode at Startup = Static</i>]:<br/> <ul style="list-style-type: none"> <li>Use parameters <i>F7-01</i> to <i>F7-04</i> [<i>IP Address 4</i>] to set the IP Address. Be sure to set a different IP address for each drive on the network.</li> <li>Also set parameters <i>F7-01</i> to <i>F7-12</i>.</li> </ul> </p> | 168<br>(0 - 255) | 360  |
| F7-03 (03E7) | IP Address 3      | <p><b>V/f</b> <b>CL-V/f</b> <b>OLV</b> <b>CLV</b> <b>AOLV</b> <b>OLV/PM</b> <b>AOLV/PM</b> <b>CLV/PM</b> <b>EZOLV</b></p> <p>Sets the third octet of the IP Address for the device that is connecting to the network. Restart the drive after you change this parameter.</p> <p><b>Note:</b><br/>When <i>F7-13 = 0</i> [<i>Address Mode at Startup = Static</i>]:<br/> <ul style="list-style-type: none"> <li>Use parameters <i>F7-01</i> to <i>F7-04</i> [<i>IP Address 4</i>] to set the IP Address. Be sure to set a different IP address for each drive on the network.</li> <li>Also set parameters <i>F7-01</i> to <i>F7-12</i>.</li> </ul> </p>  | 1<br>(0 - 255)   | 360  |
| F7-04 (03E8) | IP Address 4      | <p><b>V/f</b> <b>CL-V/f</b> <b>OLV</b> <b>CLV</b> <b>AOLV</b> <b>OLV/PM</b> <b>AOLV/PM</b> <b>CLV/PM</b> <b>EZOLV</b></p> <p>Sets the fourth octet of the IP Address for the device that is connecting to the network. Restart the drive after you change this parameter.</p> <p><b>Note:</b><br/>When <i>F7-13 = 0</i> [<i>Address Mode at Startup = Static</i>]:<br/> <ul style="list-style-type: none"> <li>Use parameters <i>F7-01</i> to <i>F7-04</i> [<i>IP Address 4</i>] to set the IP Address. Be sure to set a different IP address for each drive on the network.</li> <li>Also set parameters <i>F7-01</i> to <i>F7-12</i>.</li> </ul> </p> | 20<br>(0 - 255)  | 360  |
| F7-05 (03E9) | Subnet Mask 1     | <p><b>V/f</b> <b>CL-V/f</b> <b>OLV</b> <b>CLV</b> <b>AOLV</b> <b>OLV/PM</b> <b>AOLV/PM</b> <b>CLV/PM</b> <b>EZOLV</b></p> <p>Sets the first octet of the subnet mask of the connected network.</p> <p><b>Note:</b><br/>Set this parameter when <i>F7-13 = 0</i> [<i>Address Mode at Startup = Static</i>].</p>  | 255<br>(0 - 255) | 360  |
| F7-06 (03EA) | Subnet Mask 2     | <p><b>V/f</b> <b>CL-V/f</b> <b>OLV</b> <b>CLV</b> <b>AOLV</b> <b>OLV/PM</b> <b>AOLV/PM</b> <b>CLV/PM</b> <b>EZOLV</b></p> <p>Sets the second octet of the subnet mask of the connected network.</p> <p><b>Note:</b><br/>Set this parameter when <i>F7-13 = 0</i> [<i>Address Mode at Startup = Static</i>].</p>   | 255<br>(0 - 255) | 361  |
| F7-07 (03EB) | Subnet Mask 3     | <p><b>V/f</b> <b>CL-V/f</b> <b>OLV</b> <b>CLV</b> <b>AOLV</b> <b>OLV/PM</b> <b>AOLV/PM</b> <b>CLV/PM</b> <b>EZOLV</b></p> <p>Sets the third octet of the subnet mask of the connected network.</p> <p><b>Note:</b><br/>Set this parameter when <i>F7-13 = 0</i> [<i>Address Mode at Startup = Static</i>].</p>  | 255<br>(0 - 255) | 361  |
| F7-08 (03EC) | Subnet Mask 4     | <p><b>V/f</b> <b>CL-V/f</b> <b>OLV</b> <b>CLV</b> <b>AOLV</b> <b>OLV/PM</b> <b>AOLV/PM</b> <b>CLV/PM</b> <b>EZOLV</b></p> <p>Sets the fourth octet of the subnet mask of the connected network.</p> <p><b>Note:</b><br/>Set this parameter when <i>F7-13 = 0</i> [<i>Address Mode at Startup = Static</i>].</p>   | 0<br>(0 - 255)   | 361  |
| F7-09 (03ED) | Gateway Address 1 | <p><b>V/f</b> <b>CL-V/f</b> <b>OLV</b> <b>CLV</b> <b>AOLV</b> <b>OLV/PM</b> <b>AOLV/PM</b> <b>CLV/PM</b> <b>EZOLV</b></p> <p>Sets the first octet of the gateway address of the connected network.</p> <p><b>Note:</b><br/>Set this parameter when <i>F7-13 = 0</i> [<i>Address Mode at Startup = Static</i>].</p>  | 192<br>(0 - 255) | 361  |
| F7-10 (03EE) | Gateway Address 2 | <p><b>V/f</b> <b>CL-V/f</b> <b>OLV</b> <b>CLV</b> <b>AOLV</b> <b>OLV/PM</b> <b>AOLV/PM</b> <b>CLV/PM</b> <b>EZOLV</b></p> <p>Sets the second octet of the gateway address of the connected network.</p> <p><b>Note:</b><br/>Set this parameter when <i>F7-13 = 0</i> [<i>Address Mode at Startup = Static</i>].</p>   | 168<br>(0 - 255) | 361  |
| F7-11 (03EF) | Gateway Address 3 | <p><b>V/f</b> <b>CL-V/f</b> <b>OLV</b> <b>CLV</b> <b>AOLV</b> <b>OLV/PM</b> <b>AOLV/PM</b> <b>CLV/PM</b> <b>EZOLV</b></p> <p>Sets the third octet of the gateway address of the connected network.</p> <p><b>Note:</b><br/>Set this parameter when <i>F7-13 = 0</i> [<i>Address Mode at Startup = Static</i>].</p>  | 1<br>(0 - 255)   | 361  |

| No. (Hex.)   | Name                                   | Description   | Default (Range)         | Ref. |
|--|--|---|-------------------------|------|
| F7-12 (03F0)   | Gateway Address 4                      | <p><b>V/f</b> <b>CL-V/f</b> <b>OLV</b> <b>CLV</b> <b>AOLV</b> <b>OLV/PM</b> <b>AOLV/PM</b> <b>CLV/PM</b> <b>EZOLV</b></p> <p>Sets the fourth octet of the gateway address of the connected network.</p> <p><b>Note:</b><br/>Set this parameter when <math>F7-13 = 0</math> [Address Mode at Startup = Static].</p>  | 1<br>(0 - 255)          | 362  |
| F7-13 (03F1)   | Address Mode at Startup                | <p><b>V/f</b> <b>CL-V/f</b> <b>OLV</b> <b>CLV</b> <b>AOLV</b> <b>OLV/PM</b> <b>AOLV/PM</b> <b>CLV/PM</b> <b>EZOLV</b></p> <p>Sets the method to set option card IP addresses.</p> <p>0 : Static<br/>1 : BOOTP<br/>2 : DHCP</p> <p><b>Note:</b></p> <ul style="list-style-type: none"> <li>The following setting values are available when using the PROFINET communication option card (SI-EP3).<br/>-0 : Static<br/>-2 : DHCP</li> <li>When <math>F7-13 = 0</math>, set parameters <math>F7-01</math> to <math>F7-12</math> [IP Address 1 to Gateway Address 4] to set the IP Address. Be sure to set a different IP address for each drive on the network.</li> </ul> | 2<br>(0 - 2)            | 362  |
| F7-14 (03F2)   | Duplex Mode Selection                  | <p><b>V/f</b> <b>CL-V/f</b> <b>OLV</b> <b>CLV</b> <b>AOLV</b> <b>OLV/PM</b> <b>AOLV/PM</b> <b>CLV/PM</b> <b>EZOLV</b></p> <p>Sets the duplex mode setting method.</p> <p>0 : Half/Half<br/>1 : Auto/Auto<br/>2 : Full/Full<br/>3 : Half/Auto<br/>4 : Half/Full<br/>5 : Auto/Half<br/>6 : Auto/Full<br/>7 : Full/Half<br/>8 : Full/Auto</p>  | 1<br>(0 - 8)            | 362  |
| F7-15 (03F3)   | Communication Speed Selection          | <p><b>V/f</b> <b>CL-V/f</b> <b>OLV</b> <b>CLV</b> <b>AOLV</b> <b>OLV/PM</b> <b>AOLV/PM</b> <b>CLV/PM</b> <b>EZOLV</b></p> <p>Sets the communications speed.</p> <p>10 : 10/10 Mbps<br/>100 : 100/100 Mbps<br/>101 : 10/100 Mbps<br/>102 : 100/10 Mbps</p>   | 10<br>(10, 100 - 102)   | 362  |
| F7-16 (03F4)   | Timeout Value                          | <p><b>V/f</b> <b>CL-V/f</b> <b>OLV</b> <b>CLV</b> <b>AOLV</b> <b>OLV/PM</b> <b>AOLV/PM</b> <b>CLV/PM</b> <b>EZOLV</b></p> <p>Sets the detection time for a communications timeout.</p> <p><b>Note:</b><br/>Set this parameter to 0.0 to disable the connection timeout function.</p>  | 0.0 s<br>(0.0 - 30.0 s) | 363  |
| F7-17 (03F5)   | EtherNet/IP Speed Scaling Factor       | <p><b>V/f</b> <b>CL-V/f</b> <b>OLV</b> <b>CLV</b> <b>AOLV</b> <b>OLV/PM</b> <b>AOLV/PM</b> <b>CLV/PM</b> <b>EZOLV</b></p> <p>Sets the scaling factor for the speed monitor in the EtherNet/IP Class ID 2AH Object.</p>  | 0<br>(-15 - +15)        | 363  |
| F7-18 (03F6)   | EtherNet/IP Current Scale Factor       | <p><b>V/f</b> <b>CL-V/f</b> <b>OLV</b> <b>CLV</b> <b>AOLV</b> <b>OLV/PM</b> <b>AOLV/PM</b> <b>CLV/PM</b> <b>EZOLV</b></p> <p>Sets the scaling factor for the output current monitor in the EtherNet/IP Class ID 2AH Object.</p>   | 0<br>(-15 - +15)        | 363  |
| F7-19 (03F7)   | EtherNet/IP Torque Scale Factor        | <p><b>V/f</b> <b>CL-V/f</b> <b>OLV</b> <b>CLV</b> <b>AOLV</b> <b>OLV/PM</b> <b>AOLV/PM</b> <b>CLV/PM</b> <b>EZOLV</b></p> <p>Sets the scaling factor for the torque monitor in the EtherNet/IP Class ID 2AH Object.</p>   | 0<br>(-15 - +15)        | 363  |
| F7-20 (03F8)   | EtherNet/IP Power Scaling Factor       | <p><b>V/f</b> <b>CL-V/f</b> <b>OLV</b> <b>CLV</b> <b>AOLV</b> <b>OLV/PM</b> <b>AOLV/PM</b> <b>CLV/PM</b> <b>EZOLV</b></p> <p>Sets the scaling factor for the power monitor in the EtherNet/IP Class ID 2AH Object.</p>  | 0<br>(-15 - +15)        | 363  |
| F7-21 (03F9)   | EtherNet/IP Voltage Scale Factor       | <p><b>V/f</b> <b>CL-V/f</b> <b>OLV</b> <b>CLV</b> <b>AOLV</b> <b>OLV/PM</b> <b>AOLV/PM</b> <b>CLV/PM</b> <b>EZOLV</b></p> <p>Sets the scaling factor for the voltage monitor in the EtherNet/IP Class ID 2AH Object.</p>  | 0<br>(-15 - +15)        | 363  |
| F7-22 (03FA)   | EtherNet/IP Time Scaling               | <p><b>V/f</b> <b>CL-V/f</b> <b>OLV</b> <b>CLV</b> <b>AOLV</b> <b>OLV/PM</b> <b>AOLV/PM</b> <b>CLV/PM</b> <b>EZOLV</b></p> <p>Sets the scaling factor for the time monitor in the EtherNet/IP Class ID 2AH Object.</p>   | 0<br>(-15 - +15)        | 363  |
| F7-23 - F7-27 (03FB - 03FF)<br>F7-28 - F7-32 (0370 - 0374) | Dynamic Out Param 1 to 10 for CommCard | <p><b>V/f</b> <b>CL-V/f</b> <b>OLV</b> <b>CLV</b> <b>AOLV</b> <b>OLV/PM</b> <b>AOLV/PM</b> <b>CLV/PM</b> <b>EZOLV</b></p> <p>Sets Output Assembly 116. The drive writes the values from Output Assembly 116 to the MEMOBUS/Modbus address register that is stored for each parameter. The drive will not write the values from Output Assembly 116 to the registers when the MEMOBUS/Modbus address is 0.</p>   | 0                       | 364  |
| F7-33 - F7-42 (0375 - 037E)                                | Dynamic In Param 1 to 10 for CommCard  | <p><b>V/f</b> <b>CL-V/f</b> <b>OLV</b> <b>CLV</b> <b>AOLV</b> <b>OLV/PM</b> <b>AOLV/PM</b> <b>CLV/PM</b> <b>EZOLV</b></p> <p>Sets Input Assembly 166. The drive sends the values from the MEMOBUS/Modbus address registers stored for each parameter to Input Assembly 166. The drive returns the default register value for the option card when the MEMOBUS/Modbus address is 0 and the value sent to Input Assembly 166 is not defined.</p>  | 0                       | 364  |
| F7-60 (0780)   | PZD1 Write (Control Word)              | <p><b>V/f</b> <b>CL-V/f</b> <b>OLV</b> <b>CLV</b> <b>AOLV</b> <b>OLV/PM</b> <b>AOLV/PM</b> <b>CLV/PM</b> <b>EZOLV</b></p> <p>Sets the MEMOBUS/Modbus address for PZD1 (PPO output). PZD1 (PPO output) functions as the STW when <math>F7-60 = 0, 1, \text{ or } 2</math>.</p>   | 0                       | 364  |

## 1.9 F: Options

| No. (Hex.)   | Name                             | Description   | Default (Range) | Ref. |
|--------------|----------------------------------|---|-----------------|------|
| F7-61 (0781) | PZD2 Write (Frequency Reference) | <b>V/f</b> <b>CL-V/f</b> <b>OLV</b> <b>CLV</b> <b>AOLV</b> <b>OLV/PM</b> <b>AOLV/PM</b> <b>CLV/PM</b> <b>EZOLV</b><br>Sets the MEMOBUS/Modbus address for PZD2 (PPO output). PZD2 (PPO output) functions as the HSW when $F7-61 = 0, 1, \text{ or } 2$ .                                | 0               | 364  |
| F7-62 (0782) | PZD3 Write                       | <b>V/f</b> <b>CL-V/f</b> <b>OLV</b> <b>CLV</b> <b>AOLV</b> <b>OLV/PM</b> <b>AOLV/PM</b> <b>CLV/PM</b> <b>EZOLV</b><br>Sets the MEMOBUS/Modbus address for PZD3 (PPO output). A value of 0, 1, or 2 will disable the PZD3 (PPO output) write operation to the MEMOBUS/Modbus register.   | 0               | 364  |
| F7-63 (0783) | PZD4 Write                       | <b>V/f</b> <b>CL-V/f</b> <b>OLV</b> <b>CLV</b> <b>AOLV</b> <b>OLV/PM</b> <b>AOLV/PM</b> <b>CLV/PM</b> <b>EZOLV</b><br>Sets the MEMOBUS/Modbus address for PZD4 (PPO output). A value of 0, 1, or 2 will disable the PZD4 (PPO output) write operation to the MEMOBUS/Modbus register.   | 0               | 364  |
| F7-64 (0784) | PZD5 Write                       | <b>V/f</b> <b>CL-V/f</b> <b>OLV</b> <b>CLV</b> <b>AOLV</b> <b>OLV/PM</b> <b>AOLV/PM</b> <b>CLV/PM</b> <b>EZOLV</b><br>Sets the MEMOBUS/Modbus address for PZD5 (PPO output). A value of 0, 1, or 2 will disable the PZD5 (PPO output) write operation to the MEMOBUS/Modbus register.   | 0               | 364  |
| F7-65 (0785) | PZD6 Write                       | <b>V/f</b> <b>CL-V/f</b> <b>OLV</b> <b>CLV</b> <b>AOLV</b> <b>OLV/PM</b> <b>AOLV/PM</b> <b>CLV/PM</b> <b>EZOLV</b><br>Sets the MEMOBUS/Modbus address for PZD6 (PPO output). A value of 0, 1, or 2 will disable the PZD6 (PPO output) write operation to the MEMOBUS/Modbus register.   | 0               | 365  |
| F7-66 (0786) | PZD7 Write                       | <b>V/f</b> <b>CL-V/f</b> <b>OLV</b> <b>CLV</b> <b>AOLV</b> <b>OLV/PM</b> <b>AOLV/PM</b> <b>CLV/PM</b> <b>EZOLV</b><br>Sets the MEMOBUS/Modbus address for PZD7 (PPO output). A value of 0, 1, or 2 will disable the PZD7 (PPO output) write operation to the MEMOBUS/Modbus register.   | 0               | 365  |
| F7-67 (0787) | PZD8 Write                       | <b>V/f</b> <b>CL-V/f</b> <b>OLV</b> <b>CLV</b> <b>AOLV</b> <b>OLV/PM</b> <b>AOLV/PM</b> <b>CLV/PM</b> <b>EZOLV</b><br>Sets the MEMOBUS/Modbus address for PZD8 (PPO output). A value of 0, 1, or 2 will disable the PZD8 (PPO output) write operation to the MEMOBUS/Modbus register.   | 0               | 365  |
| F7-68 (0788) | PZD9 Write                       | <b>V/f</b> <b>CL-V/f</b> <b>OLV</b> <b>CLV</b> <b>AOLV</b> <b>OLV/PM</b> <b>AOLV/PM</b> <b>CLV/PM</b> <b>EZOLV</b><br>Sets the MEMOBUS/Modbus address for PZD9 (PPO output). A value of 0, 1, or 2 will disable the PZD9 (PPO output) write operation to the MEMOBUS/Modbus register.   | 0               | 365  |
| F7-69 (0789) | PZD10 Write                      | <b>V/f</b> <b>CL-V/f</b> <b>OLV</b> <b>CLV</b> <b>AOLV</b> <b>OLV/PM</b> <b>AOLV/PM</b> <b>CLV/PM</b> <b>EZOLV</b><br>Sets the MEMOBUS/Modbus address for PZD10 (PPO output). A value of 0, 1, or 2 will disable the PZD10 (PPO output) write operation to the MEMOBUS/Modbus register. | 0               | 365  |
| F7-70 (078A) | PZD1 Read (Status Word)          | <b>V/f</b> <b>CL-V/f</b> <b>OLV</b> <b>CLV</b> <b>AOLV</b> <b>OLV/PM</b> <b>AOLV/PM</b> <b>CLV/PM</b> <b>EZOLV</b><br>Sets the MEMOBUS/Modbus address for PZD1 (PPO Read). PZD1 (PPO input) functions as the ZSW when $F7-70 = 0$ .   | 0               | 365  |
| F7-71 (078B) | PZD2 Read (Output Frequency)     | <b>V/f</b> <b>CL-V/f</b> <b>OLV</b> <b>CLV</b> <b>AOLV</b> <b>OLV/PM</b> <b>AOLV/PM</b> <b>CLV/PM</b> <b>EZOLV</b><br>Sets the MEMOBUS/Modbus address for PZD2 (PPO Read). PZD2 (PPO input) functions as the HIW when $F7-71 = 0$ .   | 0               | 365  |
| F7-72 (078C) | PZD3 Read                        | <b>V/f</b> <b>CL-V/f</b> <b>OLV</b> <b>CLV</b> <b>AOLV</b> <b>OLV/PM</b> <b>AOLV/PM</b> <b>CLV/PM</b> <b>EZOLV</b><br>Sets the MEMOBUS/Modbus address for PZD3 (PPO Read). A value of 0 will disable the PZD3 (PPO Read) load operation from the MEMOBUS/Modbus register.               | 0               | 365  |
| F7-73 (078D) | PZD4 Read                        | <b>V/f</b> <b>CL-V/f</b> <b>OLV</b> <b>CLV</b> <b>AOLV</b> <b>OLV/PM</b> <b>AOLV/PM</b> <b>CLV/PM</b> <b>EZOLV</b><br>Sets the MEMOBUS/Modbus address for PZD4 (PPO Read). A value of 0 will disable the PZD4 (PPO Read) load operation from the MEMOBUS/Modbus register.               | 0               | 366  |
| F7-74 (078E) | PZD5 Read                        | <b>V/f</b> <b>CL-V/f</b> <b>OLV</b> <b>CLV</b> <b>AOLV</b> <b>OLV/PM</b> <b>AOLV/PM</b> <b>CLV/PM</b> <b>EZOLV</b><br>Sets the MEMOBUS/Modbus address for PZD5 (PPO Read). A value of 0 will disable the PZD5 (PPO Read) load operation from the MEMOBUS/Modbus register.               | 0               | 366  |
| F7-75 (078F) | PZD6 Read                        | <b>V/f</b> <b>CL-V/f</b> <b>OLV</b> <b>CLV</b> <b>AOLV</b> <b>OLV/PM</b> <b>AOLV/PM</b> <b>CLV/PM</b> <b>EZOLV</b><br>Sets the MEMOBUS/Modbus address for PZD6 (PPO Read). A value of 0 will disable the PZD6 (PPO Read) load operation from the MEMOBUS/Modbus register.               | 0               | 366  |
| F7-76 (0790) | PZD7 Read                        | <b>V/f</b> <b>CL-V/f</b> <b>OLV</b> <b>CLV</b> <b>AOLV</b> <b>OLV/PM</b> <b>AOLV/PM</b> <b>CLV/PM</b> <b>EZOLV</b><br>Sets the MEMOBUS/Modbus address for PZD7 (PPO Read). A value of 0 will disable the PZD7 (PPO input) load operation from the MEMOBUS/Modbus register.              | 0               | 366  |
| F7-77 (0791) | PZD8 Read                        | <b>V/f</b> <b>CL-V/f</b> <b>OLV</b> <b>CLV</b> <b>AOLV</b> <b>OLV/PM</b> <b>AOLV/PM</b> <b>CLV/PM</b> <b>EZOLV</b><br>Sets the MEMOBUS/Modbus address for PZD8 (PPO Read). A value of 0 will disable the PZD8 (PPO Read) load operation from the MEMOBUS/Modbus register.               | 0               | 366  |
| F7-78 (0792) | PZD9 Read                        | <b>V/f</b> <b>CL-V/f</b> <b>OLV</b> <b>CLV</b> <b>AOLV</b> <b>OLV/PM</b> <b>AOLV/PM</b> <b>CLV/PM</b> <b>EZOLV</b><br>Sets the MEMOBUS/Modbus address for PZD9 (PPO Read). A value of 0 will disable the PZD9 (PPO Read) load operation from the MEMOBUS/Modbus register.               | 0               | 366  |
| F7-79 (0793) | PZD10 Read                       | <b>V/f</b> <b>CL-V/f</b> <b>OLV</b> <b>CLV</b> <b>AOLV</b> <b>OLV/PM</b> <b>AOLV/PM</b> <b>CLV/PM</b> <b>EZOLV</b><br>Sets the MEMOBUS/Modbus address for PZD10 (PPO Read). A value of 0 will disable the PZD10 (PPO Read) load operation from the MEMOBUS/Modbus register.             | 0               | 366  |



## 1.10 H: Terminal Functions

### ◆ H1: Digital Inputs

| No. (Hex.)   | Name                             | Description   | Default (Range) | Ref. |
|--------------|----------------------------------|---|-----------------|------|
| H1-01 (0438) | Terminal S1 Function Selection   | <p><b>V/f</b> <b>CL-V/f</b> <b>OLV</b> <b>CLV</b> <b>AOLV</b> <b>OLV/PM</b> <b>AOLV/PM</b> <b>CLV/PM</b> <b>EZOLV</b></p> <p>Sets the function for MFDI terminal S1.</p> <p><b>Note:</b><br/>The default setting is <i>F</i> when the drive is initialized for <i>3-Wire Initialization</i> [A1-03 = 3330].</p> | 40<br>(1 - 1FF) | 368  |
| H1-02 (0439) | Terminal S2 Function Selection   | <p><b>V/f</b> <b>CL-V/f</b> <b>OLV</b> <b>CLV</b> <b>AOLV</b> <b>OLV/PM</b> <b>AOLV/PM</b> <b>CLV/PM</b> <b>EZOLV</b></p> <p>Sets the function for MFDI terminal S2.</p> <p><b>Note:</b><br/>The default setting is <i>F</i> when the drive is initialized for <i>3-Wire Initialization</i> [A1-03 = 3330].</p> | 41<br>(1 - 1FF) | 368  |
| H1-03 (0400) | Terminal S3 Function Selection   | <p><b>V/f</b> <b>CL-V/f</b> <b>OLV</b> <b>CLV</b> <b>AOLV</b> <b>OLV/PM</b> <b>AOLV/PM</b> <b>CLV/PM</b> <b>EZOLV</b></p> <p>Sets the function for MFDI terminal S3.</p>  | 24<br>(0 - 1FF) | 368  |
| H1-04 (0401) | Terminal S4 Function Selection   | <p><b>V/f</b> <b>CL-V/f</b> <b>OLV</b> <b>CLV</b> <b>AOLV</b> <b>OLV/PM</b> <b>AOLV/PM</b> <b>CLV/PM</b> <b>EZOLV</b></p> <p>Sets the function for MFDI terminal S4.</p>  | 14<br>(0 - 1FF) | 368  |
| H1-05 (0402) | Terminal S5 Function Selection   | <p><b>V/f</b> <b>CL-V/f</b> <b>OLV</b> <b>CLV</b> <b>AOLV</b> <b>OLV/PM</b> <b>AOLV/PM</b> <b>CLV/PM</b> <b>EZOLV</b></p> <p>Sets the function for MFDI terminal S5.</p> <p><b>Note:</b><br/>The default setting is <i>0</i> when the drive is initialized for <i>3-Wire Initialization</i> [A1-03 = 3330].</p> | 3<br>(0 - 1FF)  | 368  |
| H1-06 (0403) | Terminal S6 Function Selection   | <p><b>V/f</b> <b>CL-V/f</b> <b>OLV</b> <b>CLV</b> <b>AOLV</b> <b>OLV/PM</b> <b>AOLV/PM</b> <b>CLV/PM</b> <b>EZOLV</b></p> <p>Sets the function for MFDI terminal S6.</p> <p><b>Note:</b><br/>The default setting is <i>3</i> when the drive is initialized for <i>3-Wire Initialization</i> [A1-03 = 3330].</p> | 4<br>(0 - 1FF)  | 369  |
| H1-07 (0404) | Terminal S7 Function Selection   | <p><b>V/f</b> <b>CL-V/f</b> <b>OLV</b> <b>CLV</b> <b>AOLV</b> <b>OLV/PM</b> <b>AOLV/PM</b> <b>CLV/PM</b> <b>EZOLV</b></p> <p>Sets the function for MFDI terminal S7.</p> <p><b>Note:</b><br/>The default setting is <i>4</i> when the drive is initialized for <i>3-Wire Initialization</i> [A1-03 = 3330].</p> | 6<br>(0 - 1FF)  | 369  |
| H1-08 (0405) | Terminal S8 Function Selection   | <p><b>V/f</b> <b>CL-V/f</b> <b>OLV</b> <b>CLV</b> <b>AOLV</b> <b>OLV/PM</b> <b>AOLV/PM</b> <b>CLV/PM</b> <b>EZOLV</b></p> <p>Sets the function for MFDI terminal S8.</p>  | 8<br>(0 - 1FF)  | 369  |
| H1-21 (0B70) | Terminal S1 Function Selection 2 | <p><b>V/f</b> <b>CL-V/f</b> <b>OLV</b> <b>CLV</b> <b>AOLV</b> <b>OLV/PM</b> <b>AOLV/PM</b> <b>CLV/PM</b> <b>EZOLV</b></p> <p>Sets the second function for MFDI terminal S1.</p>   | F<br>(1 - 19F)  | 369  |
| H1-22 (0B71) | Terminal S2 Function Select 2    | <p><b>V/f</b> <b>CL-V/f</b> <b>OLV</b> <b>CLV</b> <b>AOLV</b> <b>OLV/PM</b> <b>AOLV/PM</b> <b>CLV/PM</b> <b>EZOLV</b></p> <p>Sets the second function for MFDI terminal S2.</p>   | F<br>(1 - 19F)  | 369  |
| H1-23 (0B72) | Terminal S3 Function Selection 2 | <p><b>V/f</b> <b>CL-V/f</b> <b>OLV</b> <b>CLV</b> <b>AOLV</b> <b>OLV/PM</b> <b>AOLV/PM</b> <b>CLV/PM</b> <b>EZOLV</b></p> <p>Sets the second function for MFDI terminal S3.</p>   | F<br>(1 - 19F)  | 369  |
| H1-24 (0B73) | Terminal S4 Function Selection 2 | <p><b>V/f</b> <b>CL-V/f</b> <b>OLV</b> <b>CLV</b> <b>AOLV</b> <b>OLV/PM</b> <b>AOLV/PM</b> <b>CLV/PM</b> <b>EZOLV</b></p> <p>Sets the second function for MFDI terminal S4.</p>   | F<br>(1 - 19F)  | 370  |
| H1-25 (0B74) | Terminal S5 Function Selection 2 | <p><b>V/f</b> <b>CL-V/f</b> <b>OLV</b> <b>CLV</b> <b>AOLV</b> <b>OLV/PM</b> <b>AOLV/PM</b> <b>CLV/PM</b> <b>EZOLV</b></p> <p>Sets the second function for MFDI terminal S5.</p>   | F<br>(1 - 19F)  | 370  |
| H1-26 (0B75) | Terminal S6 Function Selection 2 | <p><b>V/f</b> <b>CL-V/f</b> <b>OLV</b> <b>CLV</b> <b>AOLV</b> <b>OLV/PM</b> <b>AOLV/PM</b> <b>CLV/PM</b> <b>EZOLV</b></p> <p>Sets the second function for MFDI terminal S6.</p>   | F<br>(1 - 19F)  | 370  |
| H1-27 (0B76) | Terminal S7 Function Selection 2 | <p><b>V/f</b> <b>CL-V/f</b> <b>OLV</b> <b>CLV</b> <b>AOLV</b> <b>OLV/PM</b> <b>AOLV/PM</b> <b>CLV/PM</b> <b>EZOLV</b></p> <p>Sets the second function for MFDI terminal S7.</p>   | F<br>(1 - 19F)  | 370  |
| H1-28 (0B77) | Terminal S8 Function Selection 2 | <p><b>V/f</b> <b>CL-V/f</b> <b>OLV</b> <b>CLV</b> <b>AOLV</b> <b>OLV/PM</b> <b>AOLV/PM</b> <b>CLV/PM</b> <b>EZOLV</b></p> <p>Sets the second function for MFDI terminal S8.</p>   | F<br>(1 - 19F)  | 370  |
| H1-40 (0B54) | Mbus Reg 15C0h bit0 Input Func   | <p><b>V/f</b> <b>CL-V/f</b> <b>OLV</b> <b>CLV</b> <b>AOLV</b> <b>OLV/PM</b> <b>AOLV/PM</b> <b>CLV/PM</b> <b>EZOLV</b></p> <p>Selects MFDI function assigned to <i>bit 0</i> of the MEMOBUS register 15C0 (Hex.).</p>  | F<br>(1 - 19F)  | 371  |
| H1-41 (0B55) | Mbus Reg 15C0h bit1 Input Func   | <p><b>V/f</b> <b>CL-V/f</b> <b>OLV</b> <b>CLV</b> <b>AOLV</b> <b>OLV/PM</b> <b>AOLV/PM</b> <b>CLV/PM</b> <b>EZOLV</b></p> <p>Selects MFDI function assigned to <i>bit 1</i> of the MEMOBUS register 15C0 (Hex.).</p>  | F<br>(1 - 19F)  | 371  |
| H1-42 (0B56) | Mbus Reg 15C0h bit2 Input Func   | <p><b>V/f</b> <b>CL-V/f</b> <b>OLV</b> <b>CLV</b> <b>AOLV</b> <b>OLV/PM</b> <b>AOLV/PM</b> <b>CLV/PM</b> <b>EZOLV</b></p> <p>Selects MFDI function assigned to <i>bit 2</i> of the MEMOBUS register 15C0 (Hex.).</p>  | F<br>(1 - 19F)  | 371  |

■ H1-xx: MFDI Setting Values

| Setting Value | Function                         | Description  | Ref. |
|---------------|----------------------------------|--|------|
| 0             | 3-Wire Sequence                  | <input type="checkbox"/> V/f <input type="checkbox"/> CL-V/f <input type="checkbox"/> OLV <input type="checkbox"/> CLV <input type="checkbox"/> AOLV <input type="checkbox"/> OLV/PM <input type="checkbox"/> AOLV/PM <input type="checkbox"/> CLV/PM <input type="checkbox"/> EZOLV<br>Sets the direction of motor rotation for 3-wire sequence.  | 371  |
| 1             | LOCAL/REMOTE Selection           | <input type="checkbox"/> V/f <input type="checkbox"/> CL-V/f <input type="checkbox"/> OLV <input type="checkbox"/> CLV <input type="checkbox"/> AOLV <input type="checkbox"/> OLV/PM <input type="checkbox"/> AOLV/PM <input type="checkbox"/> CLV/PM <input type="checkbox"/> EZOLV<br>Sets drive control for the keypad (LOCAL) or an external source (REMOTE).<br>ON : LOCAL<br>OFF : REMOTE  | 372  |
| 2             | External Reference 1/2 Selection | <input type="checkbox"/> V/f <input type="checkbox"/> CL-V/f <input type="checkbox"/> OLV <input type="checkbox"/> CLV <input type="checkbox"/> AOLV <input type="checkbox"/> OLV/PM <input type="checkbox"/> AOLV/PM <input type="checkbox"/> CLV/PM <input type="checkbox"/> EZOLV<br>Sets the drive to use Run command source 1/2 or Reference command source 1/2 when in REMOTE Mode.<br>ON : b1-15 = [Frequency Reference Selection 2], b1-16 [Run Command Selection 2]<br>OFF : b1-01 = [Frequency Reference Selection 1], b1-02 [Run Command Selection 1] | 372  |
| 3             | Multi-Step Speed Reference 1     | <input type="checkbox"/> V/f <input type="checkbox"/> CL-V/f <input type="checkbox"/> OLV <input type="checkbox"/> CLV <input type="checkbox"/> AOLV <input type="checkbox"/> OLV/PM <input type="checkbox"/> AOLV/PM <input type="checkbox"/> CLV/PM <input type="checkbox"/> EZOLV<br>Uses speed references d1-01 to d1-16 to set a multi-step speed reference.  | 372  |
| 4             | Multi-Step Speed Reference 2     | <input type="checkbox"/> V/f <input type="checkbox"/> CL-V/f <input type="checkbox"/> OLV <input type="checkbox"/> CLV <input type="checkbox"/> AOLV <input type="checkbox"/> OLV/PM <input type="checkbox"/> AOLV/PM <input type="checkbox"/> CLV/PM <input type="checkbox"/> EZOLV<br>Uses speed references d1-01 to d1-16 to set a multi-step speed reference.  | 373  |
| 5             | Multi-Step Speed Reference 3     | <input type="checkbox"/> V/f <input type="checkbox"/> CL-V/f <input type="checkbox"/> OLV <input type="checkbox"/> CLV <input type="checkbox"/> AOLV <input type="checkbox"/> OLV/PM <input type="checkbox"/> AOLV/PM <input type="checkbox"/> CLV/PM <input type="checkbox"/> EZOLV<br>Uses speed references d1-01 to d1-16 to set a multi-step speed reference.  | 373  |
| 6             | Jog Reference Selection          | <input type="checkbox"/> V/f <input type="checkbox"/> CL-V/f <input type="checkbox"/> OLV <input type="checkbox"/> CLV <input type="checkbox"/> AOLV <input type="checkbox"/> OLV/PM <input type="checkbox"/> AOLV/PM <input type="checkbox"/> CLV/PM <input type="checkbox"/> EZOLV<br>Sets the drive to use the JOG Frequency Reference (JOG command) set in d1-17. The JOG Frequency Reference (JOG command) overrides Frequency References 1 to 16 (d1-01 to d1-16).   | 373  |
| 7             | Accel/Decel Time Selection 1     | <input type="checkbox"/> V/f <input type="checkbox"/> CL-V/f <input type="checkbox"/> OLV <input type="checkbox"/> CLV <input type="checkbox"/> AOLV <input type="checkbox"/> OLV/PM <input type="checkbox"/> AOLV/PM <input type="checkbox"/> CLV/PM <input type="checkbox"/> EZOLV<br>Sets the drive to use Acceleration/Deceleration Time 1 [C1-01, C1-02] or Acceleration/Deceleration Time 2 [C1-03, C1-04].  | 373  |
| 8             | Baseblock Command (N. O.)        | <input type="checkbox"/> V/f <input type="checkbox"/> CL-V/f <input type="checkbox"/> OLV <input type="checkbox"/> CLV <input type="checkbox"/> AOLV <input type="checkbox"/> OLV/PM <input type="checkbox"/> AOLV/PM <input type="checkbox"/> CLV/PM <input type="checkbox"/> EZOLV<br>Sets the command that stops drive output and coasts the motor to stop when the input is ON.<br>ON : Baseblock (drive output stop)<br>OFF : Normal operation  | 373  |
| 9             | Baseblock Command (N. C.)        | <input type="checkbox"/> V/f <input type="checkbox"/> CL-V/f <input type="checkbox"/> OLV <input type="checkbox"/> CLV <input type="checkbox"/> AOLV <input type="checkbox"/> OLV/PM <input type="checkbox"/> AOLV/PM <input type="checkbox"/> CLV/PM <input type="checkbox"/> EZOLV<br>Sets the command that stops drive output and coasts the motor to stop when the input terminal is OFF.<br>ON : Normal operation<br>OFF : Baseblock (drive output stop)  | 374  |
| A             | Accel/Decel Ramp Hold            | <input type="checkbox"/> V/f <input type="checkbox"/> CL-V/f <input type="checkbox"/> OLV <input type="checkbox"/> CLV <input type="checkbox"/> AOLV <input type="checkbox"/> OLV/PM <input type="checkbox"/> AOLV/PM <input type="checkbox"/> CLV/PM <input type="checkbox"/> EZOLV<br>Momentarily pauses motor acceleration and deceleration when the terminal is turned ON, retains the output frequency that was stored in the drive at the time of the pause, and restarts motor operation.   | 374  |
| B             | Overheat Alarm (oH2)             | <input type="checkbox"/> V/f <input type="checkbox"/> CL-V/f <input type="checkbox"/> OLV <input type="checkbox"/> CLV <input type="checkbox"/> AOLV <input type="checkbox"/> OLV/PM <input type="checkbox"/> AOLV/PM <input type="checkbox"/> CLV/PM <input type="checkbox"/> EZOLV<br>Sets the drive to display an oH2 [Drive Overheat Warning] alarm when the input terminal is ON. The alarm does not have an effect on drive operation.   | 374  |
| C             | Analog Terminal Enable Selection | <input type="checkbox"/> V/f <input type="checkbox"/> CL-V/f <input type="checkbox"/> OLV <input type="checkbox"/> CLV <input type="checkbox"/> AOLV <input type="checkbox"/> OLV/PM <input type="checkbox"/> AOLV/PM <input type="checkbox"/> CLV/PM <input type="checkbox"/> EZOLV<br>Sets the command that enables or disables the terminals selected in H3-14 [Analog Input Terminal Enable Sel].<br>ON : Input to the terminal selected with H3-14 is enabled<br>OFF : Input to the terminal selected with H3-14 is disabled                                | 374  |
| D             | Ignore Speed Fdbk (V/f w/o Enc)  | <input type="checkbox"/> V/f <input type="checkbox"/> CL-V/f <input type="checkbox"/> OLV <input type="checkbox"/> CLV <input type="checkbox"/> AOLV <input type="checkbox"/> OLV/PM <input type="checkbox"/> AOLV/PM <input type="checkbox"/> CLV/PM <input type="checkbox"/> EZOLV<br>Sets the command to disable speed feedback control and run the drive in V/f control or use speed feedback from the encoder.<br>ON : Speed feedback control disable (V/f Control)<br>OFF : Speed feedback control enable (Closed Loop V/f Control)                        | 374  |
| E             | ASR Integral Reset               | <input type="checkbox"/> V/f <input type="checkbox"/> CL-V/f <input type="checkbox"/> OLV <input type="checkbox"/> CLV <input type="checkbox"/> AOLV <input type="checkbox"/> OLV/PM <input type="checkbox"/> AOLV/PM <input type="checkbox"/> CLV/PM <input type="checkbox"/> EZOLV<br>Sets the command to reset the integral value and use PI control or P control for the speed control loop.<br>ON : P control<br>OFF : PI control   | 374  |
| F             | Not Used                         | <input type="checkbox"/> V/f <input type="checkbox"/> CL-V/f <input type="checkbox"/> OLV <input type="checkbox"/> CLV <input type="checkbox"/> AOLV <input type="checkbox"/> OLV/PM <input type="checkbox"/> AOLV/PM <input type="checkbox"/> CLV/PM <input type="checkbox"/> EZOLV<br>Use this setting for unused terminals or to use terminals in through mode.   | 375  |
| 10            | Up Command                       | <input type="checkbox"/> V/f <input type="checkbox"/> CL-V/f <input type="checkbox"/> OLV <input type="checkbox"/> CLV <input type="checkbox"/> AOLV <input type="checkbox"/> OLV/PM <input type="checkbox"/> AOLV/PM <input type="checkbox"/> CLV/PM <input type="checkbox"/> EZOLV<br>Sets the command to use a push button switch to increase the drive frequency reference. You must also set Setting 11 [Down Command].<br>ON : Increases the frequency reference.<br>OFF : Holds the current frequency reference.  | 375  |

| Setting Value | Function                     | Description  | Ref. |
|---------------|------------------------------|--|------|
| 11            | Down Command                 | <b>V/f</b> <b>CL-V/f</b> <b>OLV</b> <b>CLV</b> <b>AOLV</b> <b>OLV/PM</b> <b>AOLV/PM</b> <b>CLV/PM</b> <b>EZOLV</b><br>Sets the command to use a push button switch to decrease the drive frequency reference. You must also set <i>Setting 10 [Up Command]</i> .<br>ON : Decreases the frequency reference.<br>OFF : Holds the current frequency reference.  | 376  |
| 12            | Forward Jog                  | <b>V/f</b> <b>CL-V/f</b> <b>OLV</b> <b>CLV</b> <b>AOLV</b> <b>OLV/PM</b> <b>AOLV/PM</b> <b>CLV/PM</b> <b>EZOLV</b><br>Sets the command to operate the motor in the forward direction at the Jog Frequency set in <i>d1-17 [Jog Reference]</i> .  | 377  |
| 13            | Reverse Jog                  | <b>V/f</b> <b>CL-V/f</b> <b>OLV</b> <b>CLV</b> <b>AOLV</b> <b>OLV/PM</b> <b>AOLV/PM</b> <b>CLV/PM</b> <b>EZOLV</b><br>Sets the command to operate the motor in the reverse direction at the Jog Frequency set in <i>d1-17 [Jog Reference]</i> .  | 377  |
| 14            | Fault Reset Procedure        | <b>V/f</b> <b>CL-V/f</b> <b>OLV</b> <b>CLV</b> <b>AOLV</b> <b>OLV/PM</b> <b>AOLV/PM</b> <b>CLV/PM</b> <b>EZOLV</b><br>Sets the command to reset the current fault when the Run command is inactive.<br><b>Note:</b><br>The drive ignores the fault reset command when the Run command is active. Remove the Run command before trying to reset a fault.  | 378  |
| 15            | Fast Stop (N.O.)             | <b>V/f</b> <b>CL-V/f</b> <b>OLV</b> <b>CLV</b> <b>AOLV</b> <b>OLV/PM</b> <b>AOLV/PM</b> <b>CLV/PM</b> <b>EZOLV</b><br>Sets the command to ramp to stop in the deceleration time set in <i>C1-09 [Fast Stop Time]</i> when the input terminal is ON while the drive is operating.   | 378  |
| 16            | Motor 2 Selection            | <b>V/f</b> <b>CL-V/f</b> <b>OLV</b> <b>CLV</b> <b>AOLV</b> <b>OLV/PM</b> <b>AOLV/PM</b> <b>CLV/PM</b> <b>EZOLV</b><br>Sets the command for the drive to operate motor 1 or motor 2. Stop the motors before switching.<br>ON : Operate motor 2<br>OFF : Operate motor 1   | 378  |
| 17            | Fast Stop (N.C.)             | <b>V/f</b> <b>CL-V/f</b> <b>OLV</b> <b>CLV</b> <b>AOLV</b> <b>OLV/PM</b> <b>AOLV/PM</b> <b>CLV/PM</b> <b>EZOLV</b><br>Sets the command to ramp to stop in the deceleration time set in <i>C1-09 [Fast Stop Time]</i> when the input terminal is ON while the drive is operating.   | 379  |
| 18            | Timer Function               | <b>V/f</b> <b>CL-V/f</b> <b>OLV</b> <b>CLV</b> <b>AOLV</b> <b>OLV/PM</b> <b>AOLV/PM</b> <b>CLV/PM</b> <b>EZOLV</b><br>Sets the command to start the timer function. Use this setting with <i>Timer Output [H2-xx = 12]</i> .   | 379  |
| 19            | PID Disable                  | <b>V/f</b> <b>CL-V/f</b> <b>OLV</b> <b>CLV</b> <b>AOLV</b> <b>OLV/PM</b> <b>AOLV/PM</b> <b>CLV/PM</b> <b>EZOLV</b><br>Sets the command to disable PID control when <i>b5-01 = 1 to 8 [PID Mode Setting = Enabled]</i> .<br>ON : PID control disabled<br>OFF : PID control enabled  | 380  |
| 1A            | Accel/Decel Time Selection 2 | <b>V/f</b> <b>CL-V/f</b> <b>OLV</b> <b>CLV</b> <b>AOLV</b> <b>OLV/PM</b> <b>AOLV/PM</b> <b>CLV/PM</b> <b>EZOLV</b><br>Set this function and <i>H1-xx = 7 [Accel/Decel Time Selection 1]</i> together. Sets the drive to use <i>Acceleration/Deceleration Time 3 [C1-05, C1-06]</i> or <i>Acceleration/Deceleration Time 4 [C1-07, C1-08]</i> .   | 380  |
| 1B            | Programming Lockout          | <b>V/f</b> <b>CL-V/f</b> <b>OLV</b> <b>CLV</b> <b>AOLV</b> <b>OLV/PM</b> <b>AOLV/PM</b> <b>CLV/PM</b> <b>EZOLV</b><br>Sets the command to prevent parameter changes when the terminal is OFF.<br>ON : Programming Lockout<br>OFF : Parameter Write Prohibit  | 380  |
| 1E            | Reference Sample Hold        | <b>V/f</b> <b>CL-V/f</b> <b>OLV</b> <b>CLV</b> <b>AOLV</b> <b>OLV/PM</b> <b>AOLV/PM</b> <b>CLV/PM</b> <b>EZOLV</b><br>Sets the command to sample the frequency reference at terminals A1, A2, or A3 and hold the frequency reference at that frequency.  | 380  |
| 20 to 2F      | External fault               | <b>V/f</b> <b>CL-V/f</b> <b>OLV</b> <b>CLV</b> <b>AOLV</b> <b>OLV/PM</b> <b>AOLV/PM</b> <b>CLV/PM</b> <b>EZOLV</b><br>Sets a command to stop the drive when a failure or fault occurs on an external device.<br>20 : External Fault (NO-Always-Ramp)<br>21 : External Fault (NC-Always-Ramp)<br>22 : External Fault (NO-@Run-Ramp)<br>23 : External Fault (NC-@Run-Ramp)<br>24 : External Fault (NO-Always-Coast)<br>25 : External Fault (NC-Always-Coast)<br>26 : External Fault (NO-@Run-Coast)<br>27 : External Fault (NC-@Run-Coast)<br>28 : External Fault (NO-Always-FStop)<br>29 : External Fault (NC-Always-FStop)<br>2A : External Fault (NO-@Run-FStop)<br>2B : External Fault (NC-@Run-FStop)<br>2C : External Fault (NO-Always-Alarm)<br>2D : External Fault (NC-Always-Alarm)<br>2E : External Fault (NO-@Run-Alarm)<br>2F : External Fault (NC-@Run-Alarm) | 381  |
| 30            | PID Integrator Reset         | <b>V/f</b> <b>CL-V/f</b> <b>OLV</b> <b>CLV</b> <b>AOLV</b> <b>OLV/PM</b> <b>AOLV/PM</b> <b>CLV/PM</b> <b>EZOLV</b><br>Sets the command to reset and hold the PID control integral to 0 when the terminal is ON.  | 381  |
| 31            | PID Integrator Hold          | <b>V/f</b> <b>CL-V/f</b> <b>OLV</b> <b>CLV</b> <b>AOLV</b> <b>OLV/PM</b> <b>AOLV/PM</b> <b>CLV/PM</b> <b>EZOLV</b><br>Sets the command to hold the integral value of the PID control while the terminal is activated.  | 382  |

## 1.10 H: Terminal Functions

| Setting Value | Function                        | Description  | Ref. |
|---------------|---------------------------------|--|------|
| 32            | Multi-Step Speed Reference 4    | <b>V/f</b> <b>CL-V/f</b> <b>OLV</b> <b>CLV</b> <b>AOLV</b> <b>OLV/PM</b> <b>AOLV/PM</b> <b>CLV/PM</b> <b>EZOLV</b><br>Uses speed references <i>d1-01</i> to <i>d1-16</i> to set a multi-step speed reference.  | 382  |
| 34            | PID Soft Starter Disable        | <b>V/f</b> <b>CL-V/f</b> <b>OLV</b> <b>CLV</b> <b>AOLV</b> <b>OLV/PM</b> <b>AOLV/PM</b> <b>CLV/PM</b> <b>EZOLV</b><br>Sets the PID soft starter function.<br>ON : No<br>OFF : Yes  | 382  |
| 35            | PID Input (Error) Invert        | <b>V/f</b> <b>CL-V/f</b> <b>OLV</b> <b>CLV</b> <b>AOLV</b> <b>OLV/PM</b> <b>AOLV/PM</b> <b>CLV/PM</b> <b>EZOLV</b><br>Sets the command to turn the terminal ON and OFF to switch the PID input level (polarity).   | 382  |
| 3E            | PID Setpoint Selection 1        | <b>V/f</b> <b>CL-V/f</b> <b>OLV</b> <b>CLV</b> <b>AOLV</b> <b>OLV/PM</b> <b>AOLV/PM</b> <b>CLV/PM</b> <b>EZOLV</b><br>Set this function and <i>H1-xx = 3F</i> [PID Setpoint Selection 2] together. Sets the function to switch the PID setpoint to <i>b5-58</i> to <i>b5-60</i> [PID Setpoint 2 to 4].   | 382  |
| 3F            | PID Setpoint Selection 2        | <b>V/f</b> <b>CL-V/f</b> <b>OLV</b> <b>CLV</b> <b>AOLV</b> <b>OLV/PM</b> <b>AOLV/PM</b> <b>CLV/PM</b> <b>EZOLV</b><br>Set this function and <i>H1-xx = 3E</i> [PID Setpoint Selection 1] together. Sets the function to switch the PID setpoint to <i>b5-58</i> to <i>b5-60</i> [PID Setpoint 2 to 4].   | 382  |
| 40            | Forward RUN (2-Wire)            | <b>V/f</b> <b>CL-V/f</b> <b>OLV</b> <b>CLV</b> <b>AOLV</b> <b>OLV/PM</b> <b>AOLV/PM</b> <b>CLV/PM</b> <b>EZOLV</b><br>Sets the Forward Run command for 2-wire sequence 1. Set this function and <i>H1-xx = 41</i> [Reverse Run Command (2-Wire Seq)] together.<br>ON : Forward Run<br>OFF : Run Stop<br><b>Note:</b><br>• Turning ON the Forward Run command terminal and the Reverse Run command terminal will cause alarm <i>EF</i> [FWD/REV Run Command Input Error] and the motor will ramp to stop.<br>• Initialize the drive with a 2-wire sequence to set the Forward Run command to terminal S1.<br>• This function will not operate at the same time as <i>H1-xx = 42, 43</i> [Run Command/FWD/REV Command (2-Wire Seq 2)]. | 383  |
| 41            | Reverse RUN (2-Wire)            | <b>V/f</b> <b>CL-V/f</b> <b>OLV</b> <b>CLV</b> <b>AOLV</b> <b>OLV/PM</b> <b>AOLV/PM</b> <b>CLV/PM</b> <b>EZOLV</b><br>Sets the Forward Run command for 2-wire sequence 1. Set this function and <i>H1-xx = 40</i> [Forward Run Command (2-Wire Seq)] together.<br>ON : Reverse Run<br>OFF : Run Stop<br><b>Note:</b><br>• Turning ON the Forward Run command terminal and the Reverse Run command terminal will cause alarm <i>EF</i> [FWD/REV Run Command Input Error] and the motor will ramp to stop.<br>• Initialize the drive with a 2-wire sequence to set the Reverse Run command to terminal S2.<br>• This function will not operate at the same time as <i>H1-xx = 42, 43</i> [Run Command/FWD/REV Command (2-Wire Seq 2)]. | 383  |
| 42            | Run Command (2-Wire Sequence 2) | <b>V/f</b> <b>CL-V/f</b> <b>OLV</b> <b>CLV</b> <b>AOLV</b> <b>OLV/PM</b> <b>AOLV/PM</b> <b>CLV/PM</b> <b>EZOLV</b><br>Sets the Run command for 2-wire sequence 2. Set this function and <i>H1-xx = 43</i> [FWD/REV Command (2-Wire Seq 2)] together.<br>ON : Run<br>OFF : Stop<br><b>Note:</b><br>This function will not operate at the same time as <i>H1-xx = 40, 41</i> [Forward/Reverse Run Command (2-Wire Seq)].   | 383  |
| 43            | FWD/REV (2-Wire Sequence 2)     | <b>V/f</b> <b>CL-V/f</b> <b>OLV</b> <b>CLV</b> <b>AOLV</b> <b>OLV/PM</b> <b>AOLV/PM</b> <b>CLV/PM</b> <b>EZOLV</b><br>Sets the direction of motor rotation for 2-wire sequence 2. Set this function and <i>H1-xx = 42</i> [Run Command (2-Wire Sequence 2)] together.<br>ON : Reverse run<br>OFF : Forward run<br><b>Note:</b><br>This function will not operate at the same time as <i>H1-xx = 40, 41</i> [Forward/Reverse Run Command (2-Wire Seq)].   | 383  |
| 44            | Offset Frequency 1              | <b>V/f</b> <b>CL-V/f</b> <b>OLV</b> <b>CLV</b> <b>AOLV</b> <b>OLV/PM</b> <b>AOLV/PM</b> <b>CLV/PM</b> <b>EZOLV</b><br>Sets the function to add the offset frequency set in <i>d7-01</i> [Offset Frequency 1] to the frequency reference when the terminal activates.   | 384  |
| 45            | Offset Frequency 2              | <b>V/f</b> <b>CL-V/f</b> <b>OLV</b> <b>CLV</b> <b>AOLV</b> <b>OLV/PM</b> <b>AOLV/PM</b> <b>CLV/PM</b> <b>EZOLV</b><br>Sets the function to add the offset frequency set in <i>d7-02</i> [Offset Frequency 2] to the frequency reference when the terminal activates.   | 384  |
| 46            | Offset Frequency 3              | <b>V/f</b> <b>CL-V/f</b> <b>OLV</b> <b>CLV</b> <b>AOLV</b> <b>OLV/PM</b> <b>AOLV/PM</b> <b>CLV/PM</b> <b>EZOLV</b><br>Sets the function to add the offset frequency set in <i>d7-03</i> [Offset Frequency 3] to the frequency reference when the terminal activates.   | 384  |
| 47            | Node Setup (CANopen)            | <b>V/f</b> <b>CL-V/f</b> <b>OLV</b> <b>CLV</b> <b>AOLV</b> <b>OLV/PM</b> <b>AOLV/PM</b> <b>CLV/PM</b> <b>EZOLV</b><br>Sets the function in CANopen communications to start the Node Setup function to set the drive node address from the host controller.   | 384  |

| Setting Value | Function                         | Description  | Ref. |
|---------------|----------------------------------|--|------|
| 60            | DC Injection Braking Command     | <p><input type="checkbox"/> V/f <input type="checkbox"/> CL-V/f <input type="checkbox"/> OLV <input type="checkbox"/> CLV <input type="checkbox"/> AOLV <input type="checkbox"/> OLV/PM <input type="checkbox"/> AOLV/PM <input type="checkbox"/> CLV/PM <input type="checkbox"/> EZOLV</p> <p>Sets the command to use DC Injection Braking to stop the motor.</p> <p><b>Note:</b><br/>When <math>A1-02 = 8</math> [Control Method Selection = EZOLV], this function is available only if you use a PM motor.</p>  | 384  |
| 61            | Speed Search from Fmax           | <p><input type="checkbox"/> V/f <input type="checkbox"/> CL-V/f <input type="checkbox"/> OLV <input type="checkbox"/> CLV <input type="checkbox"/> AOLV <input type="checkbox"/> OLV/PM <input type="checkbox"/> AOLV/PM <input type="checkbox"/> CLV/PM <input type="checkbox"/> EZOLV</p> <p>Sets the function to start speed search using an external reference although <math>b3-01 = 0</math> [Speed Search Selection at Start = Disabled].</p> <p><b>Note:</b><br/>The drive will detect <math>oPE03</math> [Multi-Function Input Setting Err] when <math>H1-xx = 61</math> and <math>62</math> are set at the same time.</p>  | 385  |
| 62            | Speed Search from Fref           | <p><input type="checkbox"/> V/f <input type="checkbox"/> CL-V/f <input type="checkbox"/> OLV <input type="checkbox"/> CLV <input type="checkbox"/> AOLV <input type="checkbox"/> OLV/PM <input type="checkbox"/> AOLV/PM <input type="checkbox"/> CLV/PM <input type="checkbox"/> EZOLV</p> <p>Sets the function to start speed search using an external reference although <math>b3-01 = 0</math> [Speed Search Selection at Start = Disabled].</p> <p><b>Note:</b><br/>The drive will detect <math>oPE03</math> [Multi-Function Input Setting Err] when <math>H1-xx = 61</math> and <math>62</math> are set at the same time.</p>  | 385  |
| 63            | Field Weakening                  | <p><input type="checkbox"/> V/f <input type="checkbox"/> CL-V/f <input type="checkbox"/> OLV <input type="checkbox"/> CLV <input type="checkbox"/> AOLV <input type="checkbox"/> OLV/PM <input type="checkbox"/> AOLV/PM <input type="checkbox"/> CLV/PM <input type="checkbox"/> EZOLV</p> <p>Sets the function to send the Field Weakening Level and Field Weakening Frequency Limit commands set in <math>d6-01</math> [Field Weakening Level] and <math>d6-02</math> [Field Weakening Frequency Limit] when the input terminal is activated.</p>   | 385  |
| 65            | KEB Ride-Thru 1 Activate (N.C.)  | <p><input type="checkbox"/> V/f <input type="checkbox"/> CL-V/f <input type="checkbox"/> OLV <input type="checkbox"/> CLV <input type="checkbox"/> AOLV <input type="checkbox"/> OLV/PM <input type="checkbox"/> AOLV/PM <input type="checkbox"/> CLV/PM <input type="checkbox"/> EZOLV</p> <p>Sets operation of the KEB1 function through the KEB Ride-Thru 1 (N.C.).</p> <p>ON : Normal operation<br/>OFF : Deceleration during momentary power loss</p>   | 385  |
| 66            | KEB Ride-Thru 1 Activate (N.O.)  | <p><input type="checkbox"/> V/f <input type="checkbox"/> CL-V/f <input type="checkbox"/> OLV <input type="checkbox"/> CLV <input type="checkbox"/> AOLV <input type="checkbox"/> OLV/PM <input type="checkbox"/> AOLV/PM <input type="checkbox"/> CLV/PM <input type="checkbox"/> EZOLV</p> <p>Sets operation of the KEB1 function through the KEB Ride-Thru 1 (N.O.).</p> <p>ON : Deceleration during momentary power loss<br/>OFF : Normal operation</p>   | 385  |
| 67            | Communications Test Mode         | <p><input type="checkbox"/> V/f <input type="checkbox"/> CL-V/f <input type="checkbox"/> OLV <input type="checkbox"/> CLV <input type="checkbox"/> AOLV <input type="checkbox"/> OLV/PM <input type="checkbox"/> AOLV/PM <input type="checkbox"/> CLV/PM <input type="checkbox"/> EZOLV</p> <p>Set the function for the drive to self-test RS-485 serial communications operation.</p>   | 386  |
| 68            | High Slip Braking                | <p><input type="checkbox"/> V/f <input type="checkbox"/> CL-V/f <input type="checkbox"/> OLV <input type="checkbox"/> CLV <input type="checkbox"/> AOLV <input type="checkbox"/> OLV/PM <input type="checkbox"/> AOLV/PM <input type="checkbox"/> CLV/PM <input type="checkbox"/> EZOLV</p> <p>Sets the command to use high-slip braking to stop the motor.</p>  | 386  |
| 6A            | Drive Enable                     | <p><input type="checkbox"/> V/f <input type="checkbox"/> CL-V/f <input type="checkbox"/> OLV <input type="checkbox"/> CLV <input type="checkbox"/> AOLV <input type="checkbox"/> OLV/PM <input type="checkbox"/> AOLV/PM <input type="checkbox"/> CLV/PM <input type="checkbox"/> EZOLV</p> <p>Sets the function to show <math>dnE</math> [Drive Enabled] on the keypad and ignore Run commands when the terminal is OFF.</p>  | 386  |
| 71            | Torque Control                   | <p><input type="checkbox"/> V/f <input type="checkbox"/> CL-V/f <input type="checkbox"/> OLV <input type="checkbox"/> CLV <input type="checkbox"/> AOLV <input type="checkbox"/> OLV/PM <input type="checkbox"/> AOLV/PM <input type="checkbox"/> CLV/PM <input type="checkbox"/> EZOLV</p> <p>Sets the function to switch between torque control and speed control.</p> <p>ON : Torque Control<br/>OFF : Speed Control</p>  | 386  |
| 72            | Zero Servo                       | <p><input type="checkbox"/> V/f <input type="checkbox"/> CL-V/f <input type="checkbox"/> OLV <input type="checkbox"/> CLV <input type="checkbox"/> AOLV <input type="checkbox"/> OLV/PM <input type="checkbox"/> AOLV/PM <input type="checkbox"/> CLV/PM <input type="checkbox"/> EZOLV</p> <p>Sets the function to hold a stopped motor.</p>  | 387  |
| 75            | Up 2 Command                     | <p><input type="checkbox"/> V/f <input type="checkbox"/> CL-V/f <input type="checkbox"/> OLV <input type="checkbox"/> CLV <input type="checkbox"/> AOLV <input type="checkbox"/> OLV/PM <input type="checkbox"/> AOLV/PM <input type="checkbox"/> CLV/PM <input type="checkbox"/> EZOLV</p> <p>Sets the function to increase the frequency reference bias value to accelerate the motor when the terminal is activated. Set this function and <math>H1-xx = 76</math> [Down 2 Command] together.</p> <p><b>Note:</b><br/>When using this function, set the optimal bias limit value with <math>d4-08</math> and <math>d4-09</math> [Up/Down 2 Bias Upper Limit/Lower Limit].</p> | 387  |
| 76            | Down 2 Command                   | <p><input type="checkbox"/> V/f <input type="checkbox"/> CL-V/f <input type="checkbox"/> OLV <input type="checkbox"/> CLV <input type="checkbox"/> AOLV <input type="checkbox"/> OLV/PM <input type="checkbox"/> AOLV/PM <input type="checkbox"/> CLV/PM <input type="checkbox"/> EZOLV</p> <p>Sets the function to decrease the frequency reference bias value to decelerate the motor when the terminal is activated. Set this function and <math>H1-xx = 75</math> [Up 2 Command] together.</p> <p><b>Note:</b><br/>When using this function, set the optimal bias limit value with <math>d4-08</math> and <math>d4-09</math> [Up/Down 2 Bias Upper Limit/Lower Limit].</p>   | 388  |
| 77            | ASR Gain (C5-03) Select          | <p><input type="checkbox"/> V/f <input type="checkbox"/> CL-V/f <input type="checkbox"/> OLV <input type="checkbox"/> CLV <input type="checkbox"/> AOLV <input type="checkbox"/> OLV/PM <input type="checkbox"/> AOLV/PM <input type="checkbox"/> CLV/PM <input type="checkbox"/> EZOLV</p> <p>Sets the function to switch the ASR proportional gain set in <math>C5-01</math> [ASR Proportional Gain 1] and <math>C5-03</math> [ASR Proportional Gain 2].</p> <p>ON : C5-03<br/>OFF : C5-01</p>   | 388  |
| 78            | Analog TorqueRef Polarity Invert | <p><input type="checkbox"/> V/f <input type="checkbox"/> CL-V/f <input type="checkbox"/> OLV <input type="checkbox"/> CLV <input type="checkbox"/> AOLV <input type="checkbox"/> OLV/PM <input type="checkbox"/> AOLV/PM <input type="checkbox"/> CLV/PM <input type="checkbox"/> EZOLV</p> <p>Sets the rotation direction of the external torque reference.</p> <p>ON : External torque reference reverse direction<br/>OFF : External torque reference forward direction</p>   | 388  |
| 7A            | KEB Ride-Thru 2 Activate (N.C.)  | <p><input type="checkbox"/> V/f <input type="checkbox"/> CL-V/f <input type="checkbox"/> OLV <input type="checkbox"/> CLV <input type="checkbox"/> AOLV <input type="checkbox"/> OLV/PM <input type="checkbox"/> AOLV/PM <input type="checkbox"/> CLV/PM <input type="checkbox"/> EZOLV</p> <p>Sets operation of the KEB2 function through the KEB Ride-Thru 2 (N.C.).</p> <p>ON : Normal operation<br/>OFF : Deceleration during momentary power loss</p>   | 389  |

## 1.10 H: Terminal Functions

| Setting Value | Function                        | Description  | Ref. |
|---------------|---------------------------------|--|------|
| 7B            | KEB Ride-Thru 2 Activate (N.O.) | <p><b>V/f</b> <b>CL-V/f</b> <b>OLV</b> <b>CLV</b> <b>AOLV</b> <b>OLV/PM</b> <b>AOLV/PM</b> <b>CLV/PM</b> <b>EZOLV</b></p> <p>Sets operation of the KEB2 function through the KEB Ride-Thru 2 (N.O.).<br/>           ON : Deceleration during momentary power loss<br/>           OFF : Normal operation</p>  | 389  |
| 7C            | Short Circuit Braking (N.O.)    | <p><b>V/f</b> <b>CL-V/f</b> <b>OLV</b> <b>CLV</b> <b>AOLV</b> <b>OLV/PM</b> <b>AOLV/PM</b> <b>CLV/PM</b> <b>EZOLV</b></p> <p>Sets operation of Short Circuit Braking (N.O.).<br/>           ON : Short Circuit Braking is enabled.<br/>           OFF : Normal operation<br/> <b>Note:</b><br/>           When <math>A1-02 = 8</math> [Control Method Selection = EZOLV], this function is available only if you use a PM motor.</p> | 389  |
| 7D            | Short Circuit Braking (N.C.)    | <p><b>V/f</b> <b>CL-V/f</b> <b>OLV</b> <b>CLV</b> <b>AOLV</b> <b>OLV/PM</b> <b>AOLV/PM</b> <b>CLV/PM</b> <b>EZOLV</b></p> <p>Sets operation of Short Circuit Braking (N.C.).<br/>           ON : Normal operation<br/>           OFF : Short Circuit Braking is enabled.<br/> <b>Note:</b><br/>           When <math>A1-02 = 8</math> [Control Method Selection = EZOLV], this function is available only if you use a PM motor.</p> | 389  |
| 7E            | Reverse Rotation Identifier     | <p><b>V/f</b> <b>CL-V/f</b> <b>OLV</b> <b>CLV</b> <b>AOLV</b> <b>OLV/PM</b> <b>AOLV/PM</b> <b>CLV/PM</b> <b>EZOLV</b></p> <p>Sets the rotation direction of the motor when in Simple Closed Loop V/f Control method and <math>F1-21, F1-37 = 0</math> [Encoder Option Function Selection = A pulse detection], or when in Closed Loop V/f Control method.<br/>           ON : Reverse run<br/>           OFF : Forward run</p>       | 390  |
| 90 - 97       | DWEZ Digital Inputs 1 to 8      | <p><b>V/f</b> <b>CL-V/f</b> <b>OLV</b> <b>CLV</b> <b>AOLV</b> <b>OLV/PM</b> <b>AOLV/PM</b> <b>CLV/PM</b> <b>EZOLV</b></p> <p>Sets digital inputs used with DriveWorksEZ. Refer to the DriveWorksEZ online manual for more information.</p>   | 390  |
| 9F            | DWEZ Disable                    | <p><b>V/f</b> <b>CL-V/f</b> <b>OLV</b> <b>CLV</b> <b>AOLV</b> <b>OLV/PM</b> <b>AOLV/PM</b> <b>CLV/PM</b> <b>EZOLV</b></p> <p>Sets operation of the DriveWorksEZ program saved in the drive.<br/>           ON : No<br/>           OFF : Yes<br/> <b>Note:</b><br/>           Set <math>A1-07 = 2</math> [DriveWorksEZ Function Selection = Digital input] to enable this function.</p>   | 390  |
| 101 to 19F    | Inverse Input of 1 to 9F        | <p>Sets the function of the selected MFDI to operate inversely. To select the function, enter "1xx", where the "xx" is the function setting value.<br/> <b>Note:</b><br/>           You cannot use inverse input for all functions. For details, refer to Table 2.55.</p>  | 390  |

## ◆ H2: Digital Outputs

| No. (Hex.)   | Name                            | Description  | Default (Range) | Ref. |
|--------------|---------------------------------|--|-----------------|------|
| H2-01 (040B) | Term M1-M2 Function Selection   | <p><b>V/f</b> <b>CL-V/f</b> <b>OLV</b> <b>CLV</b> <b>AOLV</b> <b>OLV/PM</b> <b>AOLV/PM</b> <b>CLV/PM</b> <b>EZOLV</b></p> <p>Sets the function for MFDO terminal M1-M2.<br/> <b>Note:</b><br/>           Set this parameter to <i>F</i> when the terminal is not being used or to use the terminal in through mode.</p>  | 0<br>(0 - 1FF)  | 393  |
| H2-02 (040C) | Term M3-M4 Function Selection   | <p><b>V/f</b> <b>CL-V/f</b> <b>OLV</b> <b>CLV</b> <b>AOLV</b> <b>OLV/PM</b> <b>AOLV/PM</b> <b>CLV/PM</b> <b>EZOLV</b></p> <p>Sets the function for MFDO terminal M3-M4.<br/> <b>Note:</b><br/>           Set this parameter to <i>F</i> when the terminal is not being used or to use the terminal in through mode.</p>  | 1<br>(0 - 1FF)  | 393  |
| H2-03 (040D) | Term M5-M6 Function Selection   | <p><b>V/f</b> <b>CL-V/f</b> <b>OLV</b> <b>CLV</b> <b>AOLV</b> <b>OLV/PM</b> <b>AOLV/PM</b> <b>CLV/PM</b> <b>EZOLV</b></p> <p>Sets the function for MFDO terminal M5-M6.<br/> <b>Note:</b><br/>           Set this parameter to <i>F</i> when the terminal is not being used or to use the terminal in through mode.</p>  | 2<br>(0 - 1FF)  | 393  |
| H2-06 (0437) | Watt Hour Output Unit Selection | <p><b>V/f</b> <b>CL-V/f</b> <b>OLV</b> <b>CLV</b> <b>AOLV</b> <b>OLV/PM</b> <b>AOLV/PM</b> <b>CLV/PM</b> <b>EZOLV</b></p> <p>Sets the unit for the output signal when <math>H2-01</math> to <math>H2-03 = 39</math> [MFDO Function Selection = Watt Hour Pulse Output].<br/>           0 : 0.1 kWh units<br/>           1 : 1 kWh units<br/>           2 : 10 kWh units<br/>           3 : 100 kWh units<br/>           4 : 1000 kWh units</p> | 0<br>(0 - 4)    | 393  |

| No. (Hex.)   | Name                              | Description   | Default (Range)          | Ref. |
|--------------|-----------------------------------|---|--------------------------|------|
| H2-07 (0B3A) | Modbus Register 1 Address Select  | <b>V/f</b> <b>CL-V/f</b> <b>OLV</b> <b>CLV</b> <b>AOLV</b> <b>OLV/PM</b> <b>AOLV/PM</b> <b>CLV/PM</b> <b>EZOLV</b><br>Sets the address of the MEMOBUS/Modbus register output to the MFDO terminal.  | 0001<br>(0001 - 1FFF)    | 394  |
| H2-08 (0B3B) | Modbus Register 1 Bit Select      | <b>V/f</b> <b>CL-V/f</b> <b>OLV</b> <b>CLV</b> <b>AOLV</b> <b>OLV/PM</b> <b>AOLV/PM</b> <b>CLV/PM</b> <b>EZOLV</b><br>Sets the bit of the MEMOBUS/Modbus register output to the MFDO terminal.  | 0000<br>(0000 - FFFF)    | 394  |
| H2-09 (0B3C) | Modbus Register 2 Address Select  | <b>V/f</b> <b>CL-V/f</b> <b>OLV</b> <b>CLV</b> <b>AOLV</b> <b>OLV/PM</b> <b>AOLV/PM</b> <b>CLV/PM</b> <b>EZOLV</b><br>Sets the address of the MEMOBUS/Modbus register output to the MFDO terminal.  | 0001<br>(0001 - 1FFF)    | 394  |
| H2-10 (0B3D) | Modbus Register 2 Bit Select      | <b>V/f</b> <b>CL-V/f</b> <b>OLV</b> <b>CLV</b> <b>AOLV</b> <b>OLV/PM</b> <b>AOLV/PM</b> <b>CLV/PM</b> <b>EZOLV</b><br>Sets the bit of the MEMOBUS/Modbus register output to the MFDO terminal.  | 0000<br>(0000 - FFFF)    | 394  |
| H2-20 (1540) | Comparator 1 Monitor Selection    | <b>V/f</b> <b>CL-V/f</b> <b>OLV</b> <b>CLV</b> <b>AOLV</b> <b>OLV/PM</b> <b>AOLV/PM</b> <b>CLV/PM</b> <b>EZOLV</b><br>Sets the monitor number for comparator 1. Set the x-xx part of the Ux-xx [Monitor]. For example, set H2-20 = 102 to monitor U1-02 [Output Frequency].                         | 102<br>(000 - 999)       | 394  |
| H2-21 (1541) | Comparator 1 Lower Limit          | <b>V/f</b> <b>CL-V/f</b> <b>OLV</b> <b>CLV</b> <b>AOLV</b> <b>OLV/PM</b> <b>AOLV/PM</b> <b>CLV/PM</b> <b>EZOLV</b><br>Sets the lower limit detection level for comparator 1 when the full scale analog output for the monitor selected in H2-20 [Comparator 1 Monitor Selection] is the 100% value. | 0.0%<br>(0.0 - 300.0%)   | 395  |
| H2-22 (1542) | Comparator 1 Upper Limit          | <b>V/f</b> <b>CL-V/f</b> <b>OLV</b> <b>CLV</b> <b>AOLV</b> <b>OLV/PM</b> <b>AOLV/PM</b> <b>CLV/PM</b> <b>EZOLV</b><br>Sets the upper limit detection level for comparator 1 when the full scale analog output for the monitor selected in H2-20 [Comparator 1 Monitor Selection] is the 100% value. | 0.0%<br>(0.0 - 300.0%)   | 395  |
| H2-23 (1543) | Comparator 1 Hysteresis           | <b>V/f</b> <b>CL-V/f</b> <b>OLV</b> <b>CLV</b> <b>AOLV</b> <b>OLV/PM</b> <b>AOLV/PM</b> <b>CLV/PM</b> <b>EZOLV</b><br>Sets the hysteresis level for comparator 1 as a percentage of the full scale analog output for the monitor selected in H2-20 [Comparator 1 Monitor Selection].                | 0.0%<br>(0.0 - 10.0%)    | 395  |
| H2-24 (1544) | Comparator 1 On-Delay Time        | <b>V/f</b> <b>CL-V/f</b> <b>OLV</b> <b>CLV</b> <b>AOLV</b> <b>OLV/PM</b> <b>AOLV/PM</b> <b>CLV/PM</b> <b>EZOLV</b><br>Sets the on-delay time for comparator 1.  | 0.0 s<br>(0.0 - 600.0 s) | 395  |
| H2-25 (1545) | Comparator 1 Off-Delay Time       | <b>V/f</b> <b>CL-V/f</b> <b>OLV</b> <b>CLV</b> <b>AOLV</b> <b>OLV/PM</b> <b>AOLV/PM</b> <b>CLV/PM</b> <b>EZOLV</b><br>Sets the off-delay time for comparator 1.   | 0.0 s<br>(0.0 - 600.0 s) | 395  |
| H2-26 (1546) | Comparator 2 Monitor Selection    | <b>V/f</b> <b>CL-V/f</b> <b>OLV</b> <b>CLV</b> <b>AOLV</b> <b>OLV/PM</b> <b>AOLV/PM</b> <b>CLV/PM</b> <b>EZOLV</b><br>Sets the monitor number for comparator 2. Set the x-xx part of the Ux-xx [Monitor]. For example, set H2-26 = 103 to monitor U1-03 [Output Current].                           | 103<br>(000 - 999)       | 395  |
| H2-27 (1547) | Comparator 2 Lower Limit          | <b>V/f</b> <b>CL-V/f</b> <b>OLV</b> <b>CLV</b> <b>AOLV</b> <b>OLV/PM</b> <b>AOLV/PM</b> <b>CLV/PM</b> <b>EZOLV</b><br>Sets the lower limit detection level for comparator 2 as a percentage of the full scale analog output for the monitor selected in H2-26 [Comparator 2 Monitor Selection].     | 0.0%<br>(0.0 - 300.0%)   | 396  |
| H2-28 (1548) | Comparator 2 Upper Limit          | <b>V/f</b> <b>CL-V/f</b> <b>OLV</b> <b>CLV</b> <b>AOLV</b> <b>OLV/PM</b> <b>AOLV/PM</b> <b>CLV/PM</b> <b>EZOLV</b><br>Sets the upper limit detection level for comparator 2 as a percentage of the full scale analog output for the monitor selected in H2-26 [Comparator 2 Monitor Selection].     | 0.0%<br>(0.0 - 300.0%)   | 396  |
| H2-29 (1549) | Comparator 2 Hysteresis           | <b>V/f</b> <b>CL-V/f</b> <b>OLV</b> <b>CLV</b> <b>AOLV</b> <b>OLV/PM</b> <b>AOLV/PM</b> <b>CLV/PM</b> <b>EZOLV</b><br>Sets the hysteresis level for comparator 2 as a percentage of the full scale analog output for the monitor selected in H2-26 [Comparator 2 Monitor Selection].                | 0.0%<br>(0.0 - 10.0%)    | 396  |
| H2-30 (154A) | Comparator 2 On-Delay Time        | <b>V/f</b> <b>CL-V/f</b> <b>OLV</b> <b>CLV</b> <b>AOLV</b> <b>OLV/PM</b> <b>AOLV/PM</b> <b>CLV/PM</b> <b>EZOLV</b><br>Sets the on-delay time for comparator 2.  | 0.0 s<br>(0.0 - 600.0 s) | 396  |
| H2-31 (154B) | Comparator 2 Off-Delay Time       | <b>V/f</b> <b>CL-V/f</b> <b>OLV</b> <b>CLV</b> <b>AOLV</b> <b>OLV/PM</b> <b>AOLV/PM</b> <b>CLV/PM</b> <b>EZOLV</b><br>Sets the off-delay time for comparator 2.   | 0.0 s<br>(0.0 - 600.0 s) | 396  |
| H2-32 (159A) | Comparator 1 Filter Time          | <b>V/f</b> <b>CL-V/f</b> <b>OLV</b> <b>CLV</b> <b>AOLV</b> <b>OLV/PM</b> <b>AOLV/PM</b> <b>CLV/PM</b> <b>EZOLV</b><br>Sets the time constant that is applied to the primary delay filter used for the analog output of the monitor selected with H2-20 [Comparator 1 Monitor Selection].            | 0.0s<br>(0.0 - 10.0 s)   | 396  |
| H2-33 (159B) | Comparator 1 Protection Selection | <b>V/f</b> <b>CL-V/f</b> <b>OLV</b> <b>CLV</b> <b>AOLV</b> <b>OLV/PM</b> <b>AOLV/PM</b> <b>CLV/PM</b> <b>EZOLV</b><br>Sets drive operation when it detects CP1 [Comparator 1 Limit Fault].<br>0 : Ramp to Stop<br>1 : Coast to Stop<br>2 : Fast Stop<br>3 : Alarm Only<br>4 : Digital Output Only   | 4<br>(0 - 4)             | 397  |
| H2-34 (159C) | Comparator 2 Filter Time          | <b>V/f</b> <b>CL-V/f</b> <b>OLV</b> <b>CLV</b> <b>AOLV</b> <b>OLV/PM</b> <b>AOLV/PM</b> <b>CLV/PM</b> <b>EZOLV</b><br>Sets the time constant that is applied to the primary delay filter used for the analog output of the monitor selected with H2-26 [Comparator 2 Monitor Selection].            | 0.0s<br>(0.0 - 10.0 s)   | 397  |
| H2-35 (159D) | Comparator 2 Protection Selection | <b>V/f</b> <b>CL-V/f</b> <b>OLV</b> <b>CLV</b> <b>AOLV</b> <b>OLV/PM</b> <b>AOLV/PM</b> <b>CLV/PM</b> <b>EZOLV</b><br>Sets drive operation when it detects CP2 [Comparator 2 Limit Fault].<br>0 : Ramp to Stop<br>1 : Coast to Stop<br>2 : Fast Stop<br>3 : Alarm Only<br>4 : Digital Output Only   | 4<br>(0 - 4)             | 397  |

## 1.10 H: Terminal Functions

| No. (Hex.)          | Name                             | Description  | Default (Range)           | Ref. |
|---------------------|----------------------------------|--|---------------------------|------|
| H2-36 (159E)        | Comparator 1 Ineffective Time    | <b>V/f</b> <b>CL-V/f</b> <b>OLV</b> <b>CLV</b> <b>AOLV</b> <b>OLV/PM</b> <b>AOLV/PM</b> <b>CLV/PM</b> <b>EZOLV</b><br>Sets the length of time that CP1 [Comparator1 Limit Fault] is disabled.  | 0.0 s<br>(0.0 - 1000.0 s) | 398  |
| H2-37 (159F)        | Comparator 2 Ineffective Time    | <b>V/f</b> <b>CL-V/f</b> <b>OLV</b> <b>CLV</b> <b>AOLV</b> <b>OLV/PM</b> <b>AOLV/PM</b> <b>CLV/PM</b> <b>EZOLV</b><br>Sets the length of time that CP2 [Comparator2 Limit Fault] is disabled.  | 0.0 s<br>(0.0 - 1000.0 s) | 398  |
| H2-40 (0B58)        | Mbus Reg 15E0h bit0 Output Func  | <b>V/f</b> <b>CL-V/f</b> <b>OLV</b> <b>CLV</b> <b>AOLV</b> <b>OLV/PM</b> <b>AOLV/PM</b> <b>CLV/PM</b> <b>EZOLV</b><br>Sets the MFDO for bit 0 of MEMOBUS register 15E0 (Hex.).   | F<br>(0 - 1FF)            | 398  |
| H2-41 (0B59)        | Mbus Reg 15E0h bit1 Output Func  | <b>V/f</b> <b>CL-V/f</b> <b>OLV</b> <b>CLV</b> <b>AOLV</b> <b>OLV/PM</b> <b>AOLV/PM</b> <b>CLV/PM</b> <b>EZOLV</b><br>Sets the MFDO for bit 1 of MEMOBUS register 15E0 (Hex.).   | F<br>(0 - 1FF)            | 398  |
| H2-42 (0B5A)        | Mbus Reg 15E0h bit2 Output Func  | <b>V/f</b> <b>CL-V/f</b> <b>OLV</b> <b>CLV</b> <b>AOLV</b> <b>OLV/PM</b> <b>AOLV/PM</b> <b>CLV/PM</b> <b>EZOLV</b><br>Sets the MFDO for bit 2 of MEMOBUS register 15E0 (Hex.).   | F<br>(0 - 1FF)            | 398  |
| H2-60 (1B46) Expert | Term M1-M2 Secondary Function    | <b>V/f</b> <b>CL-V/f</b> <b>OLV</b> <b>CLV</b> <b>AOLV</b> <b>OLV/PM</b> <b>AOLV/PM</b> <b>CLV/PM</b> <b>EZOLV</b><br>Sets the second function for terminal M1-M2. The logical calculation results of the terminals assigned to functions by H2-01 [Term M1-M2 Function Selection] is output.  | F<br>(0 - FF)             | 398  |
| H2-61 (1B47) Expert | Terminal M1-M2 Logical Operation | <b>V/f</b> <b>CL-V/f</b> <b>OLV</b> <b>CLV</b> <b>AOLV</b> <b>OLV/PM</b> <b>AOLV/PM</b> <b>CLV/PM</b> <b>EZOLV</b><br>Sets the logical operation for the functions set in H2-01 [Term M1-M2 Function Selection] and H2-60 [Term M1-M2 Secondary Function].                                     | 0<br>(0 - 8)              | 398  |
| H2-62 (1B48) Expert | Terminal M1-M2 Delay Time        | <b>V/f</b> <b>CL-V/f</b> <b>OLV</b> <b>CLV</b> <b>AOLV</b> <b>OLV/PM</b> <b>AOLV/PM</b> <b>CLV/PM</b> <b>EZOLV</b><br>Sets the minimum on time used to output the logical calculation results from terminal M1-M2.   | 0.1 s<br>(0.0 - 25.0 s)   | 399  |
| H2-63 (1B49) Expert | Term M3-M4 Secondary Function    | <b>V/f</b> <b>CL-V/f</b> <b>OLV</b> <b>CLV</b> <b>AOLV</b> <b>OLV/PM</b> <b>AOLV/PM</b> <b>CLV/PM</b> <b>EZOLV</b><br>Sets the second function for terminal M3-M4. The logical calculation results of the terminals assigned to functions by H2-02 [Term M3-M4 Function Selection] is output.  | F<br>(0 - FF)             | 399  |
| H2-64 (1B4A) Expert | Terminal M3-M4 Logical Operation | <b>V/f</b> <b>CL-V/f</b> <b>OLV</b> <b>CLV</b> <b>AOLV</b> <b>OLV/PM</b> <b>AOLV/PM</b> <b>CLV/PM</b> <b>EZOLV</b><br>Sets the logical operation for the functions set in H2-02 [Term M3-M4 Function Selection] and H2-63 [Term M3-M4 Secondary Function].                                     | 0<br>(0 - 8)              | 399  |
| H2-65 (1B4B) Expert | Digital Output 2 Delay Time      | <b>V/f</b> <b>CL-V/f</b> <b>OLV</b> <b>CLV</b> <b>AOLV</b> <b>OLV/PM</b> <b>AOLV/PM</b> <b>CLV/PM</b> <b>EZOLV</b><br>Sets the minimum on time used to output the logical calculation results from terminal M3-M4.   | 0.1 s<br>(0.0 - 25.0 s)   | 399  |
| H2-66 (1B4C) Expert | Term M5-M6 Secondary Function    | <b>V/f</b> <b>CL-V/f</b> <b>OLV</b> <b>CLV</b> <b>AOLV</b> <b>OLV/PM</b> <b>AOLV/PM</b> <b>CLV/PM</b> <b>EZOLV</b><br>Sets the second function for terminal M5-M6. The logical calculation results of the terminals assigned to functions by H2-03 [Terminal M5-M6 Function Select] is output. | F<br>(0 - FF)             | 399  |
| H2-67 (1B4D) Expert | Terminal M5-M6 Logical Operation | <b>V/f</b> <b>CL-V/f</b> <b>OLV</b> <b>CLV</b> <b>AOLV</b> <b>OLV/PM</b> <b>AOLV/PM</b> <b>CLV/PM</b> <b>EZOLV</b><br>Sets the logical operation for the functions set in H2-03 [Term M5-M6 Function Selection] and H2-66 [Term M5-M6 Secondary Function].                                     | 0<br>(0 - 8)              | 399  |
| H2-68 (1B4E) Expert | Digital Output 3 Delay Time      | <b>V/f</b> <b>CL-V/f</b> <b>OLV</b> <b>CLV</b> <b>AOLV</b> <b>OLV/PM</b> <b>AOLV/PM</b> <b>CLV/PM</b> <b>EZOLV</b><br>Sets the minimum on time used to output the logical calculation results from terminal M5-M6.   | 0.1 s<br>(0.0 - 25.0 s)   | 399  |



■ H2-xx: MFDO Setting Values

| Setting Value | Function                 | Description  | Ref.          |                          |                                 |   |     |              |   |        |              |   |     |              |   |     |              |   |      |              |   |        |              |   |         |              |   |        |              |   |       |              |     |
|---------------|--------------------------|--|---------------|--------------------------|---------------------------------|---|-----|--------------|---|--------|--------------|---|-----|--------------|---|-----|--------------|---|------|--------------|---|--------|--------------|---|---------|--------------|---|--------|--------------|---|-------|--------------|-----|
| 0             | During Run               | <p><b>V/f</b> <b>CL-V/f</b> <b>OLV</b> <b>CLV</b> <b>AOLV</b> <b>OLV/PM</b> <b>AOLV/PM</b> <b>CLV/PM</b> <b>EZOLV</b></p> <p>The terminal activates when the Run command is input and when the drive is outputting a voltage.<br/>                     ON : Drive is running<br/>                     OFF : Drive is stopping</p>  | 400           |                          |                                 |   |     |              |   |        |              |   |     |              |   |     |              |   |      |              |   |        |              |   |         |              |   |        |              |   |       |              |     |
| 1             | Zero Speed               | <p><b>V/f</b> <b>CL-V/f</b> <b>OLV</b> <b>CLV</b> <b>AOLV</b> <b>OLV/PM</b> <b>AOLV/PM</b> <b>CLV/PM</b> <b>EZOLV</b></p> <p>The terminal activates when the output frequency is less than the value of <i>E1-09</i> [Minimum Output Frequency] or <i>b2-01</i> [DC Injection/Zero SpeedThreshold].</p> <p><b>Note:</b><br/>                     Parameter <i>A1-02</i> [Control Method Selection] selects which parameter is the reference.</p> <table border="1"> <thead> <tr> <th>A1-02 Setting</th> <th>Control method selection</th> <th>Parameter Used as the Reference</th> </tr> </thead> <tbody> <tr> <td>0</td> <td>V/f</td> <td><i>E1-09</i></td> </tr> <tr> <td>1</td> <td>CL-V/f</td> <td><i>E1-09</i></td> </tr> <tr> <td>2</td> <td>OLV</td> <td><i>b2-01</i></td> </tr> <tr> <td>3</td> <td>CLV</td> <td><i>E1-09</i></td> </tr> <tr> <td>4</td> <td>AOLV</td> <td><i>E1-09</i></td> </tr> <tr> <td>5</td> <td>OLV/PM</td> <td><i>E1-09</i></td> </tr> <tr> <td>6</td> <td>AOLV/PM</td> <td><i>E1-09</i></td> </tr> <tr> <td>7</td> <td>CLV/PM</td> <td><i>b2-01</i></td> </tr> <tr> <td>8</td> <td>EZOLV</td> <td><i>E1-09</i></td> </tr> </tbody> </table> <p>ON : Output frequency &lt; value of <i>E1-09</i> or <i>b2-01</i>.<br/>                     OFF : Output frequency ≥ value of <i>E1-09</i> or <i>b2-01</i>.</p> | A1-02 Setting | Control method selection | Parameter Used as the Reference | 0 | V/f | <i>E1-09</i> | 1 | CL-V/f | <i>E1-09</i> | 2 | OLV | <i>b2-01</i> | 3 | CLV | <i>E1-09</i> | 4 | AOLV | <i>E1-09</i> | 5 | OLV/PM | <i>E1-09</i> | 6 | AOLV/PM | <i>E1-09</i> | 7 | CLV/PM | <i>b2-01</i> | 8 | EZOLV | <i>E1-09</i> | 400 |
| A1-02 Setting | Control method selection | Parameter Used as the Reference  |               |                          |                                 |   |     |              |   |        |              |   |     |              |   |     |              |   |      |              |   |        |              |   |         |              |   |        |              |   |       |              |     |
| 0             | V/f                      | <i>E1-09</i>   |               |                          |                                 |   |     |              |   |        |              |   |     |              |   |     |              |   |      |              |   |        |              |   |         |              |   |        |              |   |       |              |     |
| 1             | CL-V/f                   | <i>E1-09</i>   |               |                          |                                 |   |     |              |   |        |              |   |     |              |   |     |              |   |      |              |   |        |              |   |         |              |   |        |              |   |       |              |     |
| 2             | OLV                      | <i>b2-01</i>   |               |                          |                                 |   |     |              |   |        |              |   |     |              |   |     |              |   |      |              |   |        |              |   |         |              |   |        |              |   |       |              |     |
| 3             | CLV                      | <i>E1-09</i>   |               |                          |                                 |   |     |              |   |        |              |   |     |              |   |     |              |   |      |              |   |        |              |   |         |              |   |        |              |   |       |              |     |
| 4             | AOLV                     | <i>E1-09</i>   |               |                          |                                 |   |     |              |   |        |              |   |     |              |   |     |              |   |      |              |   |        |              |   |         |              |   |        |              |   |       |              |     |
| 5             | OLV/PM                   | <i>E1-09</i>   |               |                          |                                 |   |     |              |   |        |              |   |     |              |   |     |              |   |      |              |   |        |              |   |         |              |   |        |              |   |       |              |     |
| 6             | AOLV/PM                  | <i>E1-09</i>   |               |                          |                                 |   |     |              |   |        |              |   |     |              |   |     |              |   |      |              |   |        |              |   |         |              |   |        |              |   |       |              |     |
| 7             | CLV/PM                   | <i>b2-01</i>   |               |                          |                                 |   |     |              |   |        |              |   |     |              |   |     |              |   |      |              |   |        |              |   |         |              |   |        |              |   |       |              |     |
| 8             | EZOLV                    | <i>E1-09</i>   |               |                          |                                 |   |     |              |   |        |              |   |     |              |   |     |              |   |      |              |   |        |              |   |         |              |   |        |              |   |       |              |     |
| 2             | Speed Agree 1            | <p><b>V/f</b> <b>CL-V/f</b> <b>OLV</b> <b>CLV</b> <b>AOLV</b> <b>OLV/PM</b> <b>AOLV/PM</b> <b>CLV/PM</b> <b>EZOLV</b></p> <p>The terminal turns on when the output frequency is in the range of the frequency reference ± <i>L4-02</i> [Speed Agree Detection Width].</p> <p><b>Note:</b></p> <ul style="list-style-type: none"> <li>The detection function operates in the two motor rotation directions.</li> <li>The drive outputs the motor speed status if <i>A1-02</i> = 3, 7 [CLV, CLV/PM]. It outputs the motor speed status also if <i>A1-02</i> = 4 and <i>n4-72</i> = 1.</li> </ul> <p>ON : The output frequency is in the range of “frequency reference ± <i>L4-02</i>”.<br/>                     OFF : The output frequency does not align with the frequency reference although the drive is running.</p>  | 401           |                          |                                 |   |     |              |   |        |              |   |     |              |   |     |              |   |      |              |   |        |              |   |         |              |   |        |              |   |       |              |     |
| 3             | User-Set Speed Agree 1   | <p><b>V/f</b> <b>CL-V/f</b> <b>OLV</b> <b>CLV</b> <b>AOLV</b> <b>OLV/PM</b> <b>AOLV/PM</b> <b>CLV/PM</b> <b>EZOLV</b></p> <p>The terminal activates when the output frequency is in the range of <i>L4-01</i> [Speed Agree Detection Level] ± <i>L4-02</i> [Speed Agree Detection Width] and in the range of the frequency reference ± <i>L4-02</i>.</p> <p><b>Note:</b></p> <ul style="list-style-type: none"> <li>The detection function operates in the two motor rotation directions. The drive uses the <i>L4-01</i> value as the forward/reverse detection level.</li> <li>The drive outputs the motor speed status if <i>A1-02</i> = 3, 7 [CLV, CLV/PM]. It outputs the motor speed status also if <i>A1-02</i> = 4 and <i>n4-72</i> = 1.</li> </ul> <p>ON : The output frequency is in the range of “<i>L4-01</i> ± <i>L4-02</i>” and the range of frequency reference ± <i>L4-02</i>.<br/>                     OFF : The output frequency is not in the range of “<i>L4-01</i> ± <i>L4-02</i>” or the range of frequency reference ± <i>L4-02</i>.</p>  | 401           |                          |                                 |   |     |              |   |        |              |   |     |              |   |     |              |   |      |              |   |        |              |   |         |              |   |        |              |   |       |              |     |
| 4             | Frequency Detection 1    | <p><b>V/f</b> <b>CL-V/f</b> <b>OLV</b> <b>CLV</b> <b>AOLV</b> <b>OLV/PM</b> <b>AOLV/PM</b> <b>CLV/PM</b> <b>EZOLV</b></p> <p>The terminal deactivates when the output frequency is higher than the value of <i>L4-01</i> [Speed Agree Detection Level] + <i>L4-02</i> [Speed Agree Detection Width]. After the terminal turns off, the terminal continues to remain off until the output frequency reaches the level set with <i>L4-01</i>.</p> <p><b>Note:</b></p> <ul style="list-style-type: none"> <li>The detection function operates in the two motor rotation directions. The drive uses the <i>L4-01</i> value as the forward/reverse detection level.</li> <li>The drive outputs the motor speed status if <i>A1-02</i> = 3, 7 [CLV, CLV/PM]. It outputs the motor speed status also if <i>A1-02</i> = 4 and <i>n4-72</i> = 1.</li> </ul> <p>ON : The output frequency is less than the value of <i>L4-01</i> or does not exceed the value of <i>L4-01</i> + <i>L4-02</i>.<br/>                     OFF : The output frequency is higher than the value of <i>L4-01</i> + <i>L4-02</i>.</p>   | 402           |                          |                                 |   |     |              |   |        |              |   |     |              |   |     |              |   |      |              |   |        |              |   |         |              |   |        |              |   |       |              |     |
| 5             | Frequency Detection 2    | <p><b>V/f</b> <b>CL-V/f</b> <b>OLV</b> <b>CLV</b> <b>AOLV</b> <b>OLV/PM</b> <b>AOLV/PM</b> <b>CLV/PM</b> <b>EZOLV</b></p> <p>The terminal activates when the output frequency is higher than the value of <i>L4-01</i> [Speed Agree Detection Level]. After the terminal activates, the terminal stays on until the output frequency is at the value of <i>L4-01</i> - <i>L4-02</i>.</p> <p><b>Note:</b></p> <ul style="list-style-type: none"> <li>The detection function operates in the two motor rotation directions. The drive uses the <i>L4-01</i> value as the forward/reverse detection level.</li> <li>The drive outputs the motor speed status if <i>A1-02</i> = 3, 7 [CLV, CLV/PM]. It outputs the motor speed status also if <i>A1-02</i> = 4 and <i>n4-72</i> = 1.</li> </ul> <p>ON : The output frequency is higher than the value of <i>L4-01</i>.<br/>                     OFF : The output frequency is less than the value of “<i>L4-01</i> - <i>L4-02</i>”, or it is not higher than the value of <i>L4-01</i>.</p>  | 402           |                          |                                 |   |     |              |   |        |              |   |     |              |   |     |              |   |      |              |   |        |              |   |         |              |   |        |              |   |       |              |     |

## 1.10 H: Terminal Functions

| Setting Value | Function                        | Description  | Ref. |
|---------------|---------------------------------|--|------|
| 6             | Drive ready                     | <b>V/f</b> <b>CL-V/f</b> <b>OLV</b> <b>CLV</b> <b>AOLV</b> <b>OLV/PM</b> <b>AOLV/PM</b> <b>CLV/PM</b> <b>EZOLV</b><br>The terminal activates when the drive is ready and running.  | 403  |
| 7             | DC Bus Undervoltage             | <b>V/f</b> <b>CL-V/f</b> <b>OLV</b> <b>CLV</b> <b>AOLV</b> <b>OLV/PM</b> <b>AOLV/PM</b> <b>CLV/PM</b> <b>EZOLV</b><br>The terminal activates when the DC bus voltage or control circuit power supply is less than the voltage set with L2-05 [Undervoltage Detection Lvl (Uv1)]. The terminal also turns on when there is a fault with the DC bus voltage.<br>ON : The DC bus voltage is less than the setting value of L2-05.<br>OFF : The DC bus voltage is more than the setting value of L2-05.  | 403  |
| 8             | During Baseblock (N.O.)         | <b>V/f</b> <b>CL-V/f</b> <b>OLV</b> <b>CLV</b> <b>AOLV</b> <b>OLV/PM</b> <b>AOLV/PM</b> <b>CLV/PM</b> <b>EZOLV</b><br>The terminal turns on during baseblock. When the drive is in baseblock, the drive output transistor stops switching and does not make DC bus voltage.<br>ON : During baseblock<br>OFF : The drive is not in baseblock.   | 403  |
| 9             | Frequency Reference from Keypad | <b>V/f</b> <b>CL-V/f</b> <b>OLV</b> <b>CLV</b> <b>AOLV</b> <b>OLV/PM</b> <b>AOLV/PM</b> <b>CLV/PM</b> <b>EZOLV</b><br>Shows the selected frequency reference source.<br>ON : The keypad is the frequency reference source.<br>OFF : Parameter b1-01 or b1-15 [Frequency Reference Selection 1 or 2] is the frequency reference source.   | 403  |
| A             | Run Command Source              | <b>V/f</b> <b>CL-V/f</b> <b>OLV</b> <b>CLV</b> <b>AOLV</b> <b>OLV/PM</b> <b>AOLV/PM</b> <b>CLV/PM</b> <b>EZOLV</b><br>Shows the selected Run command source.<br>ON : The keypad is the Run command source.<br>OFF : Parameter b1-02 or b1-16 [Run Command Selection 1 or 2] is the Run command source.   | 404  |
| B             | Torque Detection 1 (N.O.)       | <b>V/f</b> <b>CL-V/f</b> <b>OLV</b> <b>CLV</b> <b>AOLV</b> <b>OLV/PM</b> <b>AOLV/PM</b> <b>CLV/PM</b> <b>EZOLV</b><br>The terminal activates when the drive detects overtorque or undertorque.<br>ON : The output current/torque is more than the torque value set with L6-02 [Torque Detection Level 1], or the level is less than the torque value set with L6-02 for longer than the time set with L6-03 [Torque Detection Time 1].   | 404  |
| C             | Frequency Reference Loss        | <b>V/f</b> <b>CL-V/f</b> <b>OLV</b> <b>CLV</b> <b>AOLV</b> <b>OLV/PM</b> <b>AOLV/PM</b> <b>CLV/PM</b> <b>EZOLV</b><br>The terminal activates when the drive detects a loss of frequency reference.   | 404  |
| D             | Braking Resistor Fault          | <b>V/f</b> <b>CL-V/f</b> <b>OLV</b> <b>CLV</b> <b>AOLV</b> <b>OLV/PM</b> <b>AOLV/PM</b> <b>CLV/PM</b> <b>EZOLV</b><br>The terminal activates when the mounting-type braking resistor is overheating or when there is a braking transistor fault.   | 404  |
| E             | Faults                          | <b>V/f</b> <b>CL-V/f</b> <b>OLV</b> <b>CLV</b> <b>AOLV</b> <b>OLV/PM</b> <b>AOLV/PM</b> <b>CLV/PM</b> <b>EZOLV</b><br>The terminal activates when the drive detects a fault.<br><b>Note:</b><br>The terminal will not turn on for CPF00 and CPF01 [Control Circuit Error] faults.  | 404  |
| F             | Not Used                        | <b>V/f</b> <b>CL-V/f</b> <b>OLV</b> <b>CLV</b> <b>AOLV</b> <b>OLV/PM</b> <b>AOLV/PM</b> <b>CLV/PM</b> <b>EZOLV</b><br>Use this setting for unused terminals or to use terminals in through mode. Also use this setting as the PLC contact output via MEMOBUS/Modbus or the communication option. This signal does not function if signals from the PLC are not configured.   | 404  |
| 10            | Alarm                           | <b>V/f</b> <b>CL-V/f</b> <b>OLV</b> <b>CLV</b> <b>AOLV</b> <b>OLV/PM</b> <b>AOLV/PM</b> <b>CLV/PM</b> <b>EZOLV</b><br>The terminal turns on when the drive detects a minor fault.  | 404  |
| 11            | Fault Reset Command Active      | <b>V/f</b> <b>CL-V/f</b> <b>OLV</b> <b>CLV</b> <b>AOLV</b> <b>OLV/PM</b> <b>AOLV/PM</b> <b>CLV/PM</b> <b>EZOLV</b><br>The terminal turns on when the drive receives the Reset command from the control circuit terminal, serial communications, or the communication option.   | 405  |
| 12            | Timer Output                    | <b>V/f</b> <b>CL-V/f</b> <b>OLV</b> <b>CLV</b> <b>AOLV</b> <b>OLV/PM</b> <b>AOLV/PM</b> <b>CLV/PM</b> <b>EZOLV</b><br>Use this setting when the drive uses the timer function as an output terminal.   | 405  |
| 13            | Speed Agree 2                   | <b>V/f</b> <b>CL-V/f</b> <b>OLV</b> <b>CLV</b> <b>AOLV</b> <b>OLV/PM</b> <b>AOLV/PM</b> <b>CLV/PM</b> <b>EZOLV</b><br>The terminal activates when the output frequency is in the range of the frequency reference $\pm L4-04$ [Speed Agree Detection Width (+/-)].<br><b>Note:</b><br>• The detection function operates in the two motor rotation directions.<br>• The drive outputs the motor speed status if A1-02 = 3, 7 [Control Method Selection = CLV, CLV/PM].<br>ON : The output frequency is in the range of "frequency reference $\pm L4-04$ ".<br>OFF : The output frequency is not in the range of "frequency reference $\pm L4-04$ ".   | 405  |
| 14            | User-Set Speed Agree 2          | <b>V/f</b> <b>CL-V/f</b> <b>OLV</b> <b>CLV</b> <b>AOLV</b> <b>OLV/PM</b> <b>AOLV/PM</b> <b>CLV/PM</b> <b>EZOLV</b><br>The terminal activates when the output frequency is in the range of L4-03 [Speed Agree Detection Level (+/-)] $\pm L4-04$ [Speed Agree Detection Width (+/-)] and in the range of the frequency reference $\pm L4-04$ .<br><b>Note:</b><br>• The detection level configured with L4-03 is a signed value. The drive will only detect in one direction.<br>• The drive outputs the motor speed status if A1-02 = 3, 7 [Control Method Selection = CLV, CLV/PM].<br>ON : The output frequency is in the range of "L4-03 $\pm L4-04$ " and the range of frequency reference $\pm L4-04$ .<br>OFF : The output frequency is not in the range of "L4-03 $\pm L4-04$ " or the range of frequency reference $\pm L4-04$ . | 405  |

| Setting Value | Function                       | Description   | Ref. |
|---------------|--------------------------------|---|------|
| 15            | Frequency Detection 3          | <p><b>V/f</b> <b>CL-V/f</b> <b>OLV</b> <b>CLV</b> <b>AOLV</b> <b>OLV/PM</b> <b>AOLV/PM</b> <b>CLV/PM</b> <b>EZOLV</b></p> <p>The terminal deactivates when the output frequency is higher than the value of "L4-03 [Speed Agree Detection Level (+/-)] + L4-04 [Speed Agree Detection Width (+/-)]". After the terminal deactivates, the terminal stays off until the output frequency is at the value of L4-03.</p> <p><b>Note:</b></p> <ul style="list-style-type: none"> <li>The detection level configured with L4-03 is a signed value. The drive will only detect in one direction.</li> <li>The drive outputs the motor speed status if A1-02 = 3, 7 [Control Method Selection = CLV, CLV/PM].</li> </ul> <p>ON : The output frequency is less than the value of L4-03 or is not higher than the value of L4-03 + L4-04.<br/>OFF : The output frequency is higher than the value of L4-03 + L4-04.</p> | 406  |
| 16            | Frequency Detection 4          | <p><b>V/f</b> <b>CL-V/f</b> <b>OLV</b> <b>CLV</b> <b>AOLV</b> <b>OLV/PM</b> <b>AOLV/PM</b> <b>CLV/PM</b> <b>EZOLV</b></p> <p>The terminal activates when the output frequency is higher than the value of L4-03 [Speed Agree Detection Level (+/-)]. After the terminal activates, the terminal stays on until the output frequency is at the value of L4-03 - L4-04.</p> <p><b>Note:</b></p> <ul style="list-style-type: none"> <li>The detection level configured with L4-03 is a signed value. The drive will only detect in one direction.</li> <li>The drive outputs the motor speed status if A1-02 = 3, 7 [Control Method Selection = CLV, CLV/PM].</li> </ul> <p>ON : The output frequency is higher than the value of L4-03.<br/>OFF : The output frequency is less than the value of "L4-03 - L4-04", or it is not higher than the value of L4-03.</p>  | 406  |
| 17            | Torque Detection 1 (N.C.)      | <p><b>V/f</b> <b>CL-V/f</b> <b>OLV</b> <b>CLV</b> <b>AOLV</b> <b>OLV/PM</b> <b>AOLV/PM</b> <b>CLV/PM</b> <b>EZOLV</b></p> <p>The terminal deactivates when the drive detects overtorque or undertorque.</p> <p>OFF : The output current/torque is more than the torque value set with L6-02 [Torque Detection Level 1], or the level is less than the torque value set with L6-02 [Torque Detection Level 1] for longer than the time set with L6-03 [Torque Detection Time 1].</p>   | 407  |
| 18            | Torque Detection 2 (N.O.)      | <p><b>V/f</b> <b>CL-V/f</b> <b>OLV</b> <b>CLV</b> <b>AOLV</b> <b>OLV/PM</b> <b>AOLV/PM</b> <b>CLV/PM</b> <b>EZOLV</b></p> <p>The terminal activates when the drive detects overtorque or undertorque.</p> <p>ON : The output current/torque is more than the torque value set with L6-05 [Torque Detection Level 2], or the level is less than the torque value set with L6-05 [Torque Detection Level 2] for longer than the time set with L6-06 [Torque Detection Time 2].</p>  | 407  |
| 19            | Torque Detection 2 (N.C.)      | <p><b>V/f</b> <b>CL-V/f</b> <b>OLV</b> <b>CLV</b> <b>AOLV</b> <b>OLV/PM</b> <b>AOLV/PM</b> <b>CLV/PM</b> <b>EZOLV</b></p> <p>The terminal deactivates when the drive detects overtorque or undertorque.</p> <p>OFF : The output current/torque is more than the torque value set with L6-05 [Torque Detection Level 2], or the level is less than the torque value set with L6-05 [Torque Detection Level 2] for longer than the time set with L6-06 [Torque Detection Time 2].</p>   | 407  |
| 1A            | During reverse                 | <p><b>V/f</b> <b>CL-V/f</b> <b>OLV</b> <b>CLV</b> <b>AOLV</b> <b>OLV/PM</b> <b>AOLV/PM</b> <b>CLV/PM</b> <b>EZOLV</b></p> <p>The terminal activates when the motor operates in the reverse direction.</p> <p>ON : The motor is operating in the reverse direction.<br/>OFF : The motor is operating in the forward direction or the motor stopped.</p>  | 408  |
| 1B            | During Baseblock (N.C.)        | <p><b>V/f</b> <b>CL-V/f</b> <b>OLV</b> <b>CLV</b> <b>AOLV</b> <b>OLV/PM</b> <b>AOLV/PM</b> <b>CLV/PM</b> <b>EZOLV</b></p> <p>The terminal deactivates during baseblock. When the drive is in baseblock, the drive output transistor stops switching and does not make DC bus voltage.</p> <p>ON : The drive is not in baseblock.<br/>OFF : During baseblock</p>   | 408  |
| 1C            | Motor 2 Selection              | <p><b>V/f</b> <b>CL-V/f</b> <b>OLV</b> <b>CLV</b> <b>AOLV</b> <b>OLV/PM</b> <b>AOLV/PM</b> <b>CLV/PM</b> <b>EZOLV</b></p> <p>The terminal activates when motor 2 is selected.</p> <p>ON : Motor 2 Selection<br/>OFF : Motor 1 Selection</p>   | 408  |
| 1D            | During Regeneration            | <p><b>V/f</b> <b>CL-V/f</b> <b>OLV</b> <b>CLV</b> <b>AOLV</b> <b>OLV/PM</b> <b>AOLV/PM</b> <b>CLV/PM</b> <b>EZOLV</b></p> <p>The terminal activates on when the motor is regenerating.</p> <p>ON : Motor is regenerating.<br/>OFF : Motor is operating or stopped.</p>  | 408  |
| 1E            | Executing Auto-Restart         | <p><b>V/f</b> <b>CL-V/f</b> <b>OLV</b> <b>CLV</b> <b>AOLV</b> <b>OLV/PM</b> <b>AOLV/PM</b> <b>CLV/PM</b> <b>EZOLV</b></p> <p>The terminal activates when the Auto Restart function is trying to restart after a fault.</p>  | 408  |
| 1F            | Motor Overload Alarm (oL1)     | <p><b>V/f</b> <b>CL-V/f</b> <b>OLV</b> <b>CLV</b> <b>AOLV</b> <b>OLV/PM</b> <b>AOLV/PM</b> <b>CLV/PM</b> <b>EZOLV</b></p> <p>The terminal activates when the electronic thermal protection value of the motor overload protective function is a minimum of 90% of the detection level.</p>  | 409  |
| 20            | Drive Overheat Pre-Alarm (oH)  | <p><b>V/f</b> <b>CL-V/f</b> <b>OLV</b> <b>CLV</b> <b>AOLV</b> <b>OLV/PM</b> <b>AOLV/PM</b> <b>CLV/PM</b> <b>EZOLV</b></p> <p>The terminal activates when the drive heatsink temperature is at the level set with L8-02 [Overheat Alarm Level].</p>  | 409  |
| 21            | Safety Monitor Output Status   | <p><b>V/f</b> <b>CL-V/f</b> <b>OLV</b> <b>CLV</b> <b>AOLV</b> <b>OLV/PM</b> <b>AOLV/PM</b> <b>CLV/PM</b> <b>EZOLV</b></p> <p>The terminal turns on (safety stop state) when the safety circuit and safety diagnosis circuit are operating correctly and when terminals H1-HC and H2-HC are off (Open).</p> <p>ON : Safety stop state<br/>OFF : Safety circuit fault or RUN/READY</p>  | 409  |
| 22            | Mechanical Weakening Detection | <p><b>V/f</b> <b>CL-V/f</b> <b>OLV</b> <b>CLV</b> <b>AOLV</b> <b>OLV/PM</b> <b>AOLV/PM</b> <b>CLV/PM</b> <b>EZOLV</b></p> <p>The terminal activates when the drive detects mechanical weakening.</p>  | 409  |

## 1.10 H: Terminal Functions

| Setting Value | Function                         | Description   | Ref. |
|---------------|----------------------------------|---|------|
| 2F            | Maintenance Notification         | <p><b>V/f</b> <b>CL-V/f</b> <b>OLV</b> <b>CLV</b> <b>AOLV</b> <b>OLV/PM</b> <b>AOLV/PM</b> <b>CLV/PM</b> <b>EZOLV</b></p> <p>The terminal activates when drive components are at their estimated maintenance period.<br/>Tells the user about the maintenance period for these items:</p> <ul style="list-style-type: none"> <li>• IGBT</li> <li>• Cooling fan</li> <li>• Capacitor</li> <li>• Soft charge bypass relay</li> </ul>  | 409  |
| 30            | During Torque Limit              | <p><b>V/f</b> <b>CL-V/f</b> <b>OLV</b> <b>CLV</b> <b>AOLV</b> <b>OLV/PM</b> <b>AOLV/PM</b> <b>CLV/PM</b> <b>EZOLV</b></p> <p>The terminal activates when the torque reference is the torque limit set with <i>L7 parameters, H3-02, H3-06, or H3-10 [MFAI Function Selection]</i>.</p>  | 410  |
| 31            | During Speed Limit               | <p><b>V/f</b> <b>CL-V/f</b> <b>OLV</b> <b>CLV</b> <b>AOLV</b> <b>OLV/PM</b> <b>AOLV/PM</b> <b>CLV/PM</b> <b>EZOLV</b></p> <p>The terminal activates when the speed limit is active.</p>   | 410  |
| 32            | In Speed Limit During Trq Ctrl   | <p><b>V/f</b> <b>CL-V/f</b> <b>OLV</b> <b>CLV</b> <b>AOLV</b> <b>OLV/PM</b> <b>AOLV/PM</b> <b>CLV/PM</b> <b>EZOLV</b></p> <p>The motor accelerates in the forward direction or the reverse direction after enabling torque control and the externally input torque reference is disproportionate to the load. The output terminal activates when this speed is not higher than a constant speed and the motor speed is at the speed limit. This does not include operation when the drive is stopped.</p> | 410  |
| 33            | Zero Servo Complete              | <p><b>V/f</b> <b>CL-V/f</b> <b>OLV</b> <b>CLV</b> <b>AOLV</b> <b>OLV/PM</b> <b>AOLV/PM</b> <b>CLV/PM</b> <b>EZOLV</b></p> <p>The terminal activates when positioning in the range set with <i>b9-02 [Zero Servo Completion Window]</i> completes after sending the Zero-Servo command.</p>  | 410  |
| 37            | During Frequency Output          | <p><b>V/f</b> <b>CL-V/f</b> <b>OLV</b> <b>CLV</b> <b>AOLV</b> <b>OLV/PM</b> <b>AOLV/PM</b> <b>CLV/PM</b> <b>EZOLV</b></p> <p>The terminal activates when the drive outputs frequency.<br/>ON : The drive outputs frequency.<br/>OFF : The drive does not output frequency.</p>  | 410  |
| 38            | Drive Enabled                    | <p><b>V/f</b> <b>CL-V/f</b> <b>OLV</b> <b>CLV</b> <b>AOLV</b> <b>OLV/PM</b> <b>AOLV/PM</b> <b>CLV/PM</b> <b>EZOLV</b></p> <p>This terminal activates when the <i>H1-xx = 6A [Drive Enable]</i> terminal activates.</p>  | 411  |
| 39            | Watt Hour Pulse Output           | <p><b>V/f</b> <b>CL-V/f</b> <b>OLV</b> <b>CLV</b> <b>AOLV</b> <b>OLV/PM</b> <b>AOLV/PM</b> <b>CLV/PM</b> <b>EZOLV</b></p> <p>Outputs the pulse that shows the watt hours.</p>   | 411  |
| 3C            | LOCAL Control Selected           | <p><b>V/f</b> <b>CL-V/f</b> <b>OLV</b> <b>CLV</b> <b>AOLV</b> <b>OLV/PM</b> <b>AOLV/PM</b> <b>CLV/PM</b> <b>EZOLV</b></p> <p>The terminal activates when the Run command source or frequency reference source is LOCAL.<br/>ON : LOCAL<br/>OFF : REMOTE</p>   | 411  |
| 3D            | During Speed Search              | <p><b>V/f</b> <b>CL-V/f</b> <b>OLV</b> <b>CLV</b> <b>AOLV</b> <b>OLV/PM</b> <b>AOLV/PM</b> <b>CLV/PM</b> <b>EZOLV</b></p> <p>The terminal activates when the drive is doing speed search.</p>   | 411  |
| 3E            | PID Feedback Low                 | <p><b>V/f</b> <b>CL-V/f</b> <b>OLV</b> <b>CLV</b> <b>AOLV</b> <b>OLV/PM</b> <b>AOLV/PM</b> <b>CLV/PM</b> <b>EZOLV</b></p> <p>The terminal activates when the drive detects <i>FbL [PID Feedback Loss]</i>.</p>  | 411  |
| 3F            | PID Feedback High                | <p><b>V/f</b> <b>CL-V/f</b> <b>OLV</b> <b>CLV</b> <b>AOLV</b> <b>OLV/PM</b> <b>AOLV/PM</b> <b>CLV/PM</b> <b>EZOLV</b></p> <p>The terminal activates when the drive detects <i>FbH [Excessive PID Feedback]</i>.</p>   | 412  |
| 4A            | During KEB Ride-Thru             | <p><b>V/f</b> <b>CL-V/f</b> <b>OLV</b> <b>CLV</b> <b>AOLV</b> <b>OLV/PM</b> <b>AOLV/PM</b> <b>CLV/PM</b> <b>EZOLV</b></p> <p>The activates during KEB Ride-Thru.</p>  | 412  |
| 4B            | During Short Circuit Braking     | <p><b>V/f</b> <b>CL-V/f</b> <b>OLV</b> <b>CLV</b> <b>AOLV</b> <b>OLV/PM</b> <b>AOLV/PM</b> <b>CLV/PM</b> <b>EZOLV</b></p> <p>The terminal activates during Short Circuit Braking.<br/><b>Note:</b><br/>When <i>A1-02 = 8 [Control Method Selection = EZOLV]</i>, this function is available if you use a PM motor.</p>  | 412  |
| 4C            | During Fast Stop                 | <p><b>V/f</b> <b>CL-V/f</b> <b>OLV</b> <b>CLV</b> <b>AOLV</b> <b>OLV/PM</b> <b>AOLV/PM</b> <b>CLV/PM</b> <b>EZOLV</b></p> <p>The terminal activates when the fast stop is in operation.</p>   | 412  |
| 4D            | oH Pre-Alarm Time Limit          | <p><b>V/f</b> <b>CL-V/f</b> <b>OLV</b> <b>CLV</b> <b>AOLV</b> <b>OLV/PM</b> <b>AOLV/PM</b> <b>CLV/PM</b> <b>EZOLV</b></p> <p>The terminal activates when <i>L8-03 = 4 [Overheat Pre-Alarm Selection = Operate at Reduced Speed (L8-19)]</i> and <i>oH [Heatsink Overheat]</i> does not clear after the drive decreases the frequency for 10 cycles.</p>   | 412  |
| 4E            | Braking Transistor Fault (tr)    | <p><b>V/f</b> <b>CL-V/f</b> <b>OLV</b> <b>CLV</b> <b>AOLV</b> <b>OLV/PM</b> <b>AOLV/PM</b> <b>CLV/PM</b> <b>EZOLV</b></p> <p>The terminal activates when the internal braking transistor overheats and the drive detects an <i>rr [Dynamic Braking Transistor Fault]</i> fault.</p>   | 412  |
| 4F            | Braking Resistor Overheat (rH)   | <p><b>V/f</b> <b>CL-V/f</b> <b>OLV</b> <b>CLV</b> <b>AOLV</b> <b>OLV/PM</b> <b>AOLV/PM</b> <b>CLV/PM</b> <b>EZOLV</b></p> <p>The terminal activates when the braking resistor overheats and the drive detects an <i>rH [Braking Resistor Overheat]</i> fault.</p>   | 412  |
| 60            | Internal Cooling Fan Alarm       | <p><b>V/f</b> <b>CL-V/f</b> <b>OLV</b> <b>CLV</b> <b>AOLV</b> <b>OLV/PM</b> <b>AOLV/PM</b> <b>CLV/PM</b> <b>EZOLV</b></p> <p>The terminal activates when the drive detects a cooling fan failure in the drive.</p>  | 413  |
| 61            | Pole Position Detection Complete | <p><b>V/f</b> <b>CL-V/f</b> <b>OLV</b> <b>CLV</b> <b>AOLV</b> <b>OLV/PM</b> <b>AOLV/PM</b> <b>CLV/PM</b> <b>EZOLV</b></p> <p>The terminal activates when drive receives a Run command and the drive detects the motor magnetic pole position of the PM motor.</p>   | 413  |

| Setting Value | Function                            | Description   | Ref. |
|---------------|-------------------------------------|---|------|
| 62            | Modbus Reg 1 Status Satisfied       | <b>V/f</b> <b>CL-V/f</b> <b>OLV</b> <b>CLV</b> <b>AOLV</b> <b>OLV/PM</b> <b>AOLV/PM</b> <b>CLV/PM</b> <b>EZOLV</b><br>The terminal activates when the bit specified by H2-08 [Modbus Register 1 Bit Select] for the MEMOBUS register address set with H2-07 [Modbus Register 1 Address Select] activates.   | 413  |
| 63            | Modbus Reg 2 Status Satisfied       | <b>V/f</b> <b>CL-V/f</b> <b>OLV</b> <b>CLV</b> <b>AOLV</b> <b>OLV/PM</b> <b>AOLV/PM</b> <b>CLV/PM</b> <b>EZOLV</b><br>The terminal activates when the bit specified by H2-10 [Modbus Register 2 Bit Select] for the MEMOBUS register address set with H2-09 [Modbus Register 2 Address Select] activates.   | 413  |
| 65            | Standby Output                      | <b>V/f</b> <b>CL-V/f</b> <b>OLV</b> <b>CLV</b> <b>AOLV</b> <b>OLV/PM</b> <b>AOLV/PM</b> <b>CLV/PM</b> <b>EZOLV</b><br>The terminal deactivates after the drive stops operating and after the time set with b8-51 [Standby Mode Wait Time].<br>ON : The Run command turns on and the magnetic contactor on the input side turns on.<br>OFF : The Run command turns off and the drive stops operating. Then, the magnetic contactor on the input side turns off after the time set with b8-51 [Standby Mode Wait Time] elapses. | 413  |
| 66            | Comparator1                         | <b>V/f</b> <b>CL-V/f</b> <b>OLV</b> <b>CLV</b> <b>AOLV</b> <b>OLV/PM</b> <b>AOLV/PM</b> <b>CLV/PM</b> <b>EZOLV</b><br>The terminal activates if the monitor value set with H2-20 [Comparator 1 Monitor Selection] is in range of the values of H2-21 [Comparator 1 Lower Limit] and H2-22 [Comparator 1 Upper Limit] for the time set with H2-24 [Comparator 1 On-Delay Time].  | 413  |
| 67            | Comparator2                         | <b>V/f</b> <b>CL-V/f</b> <b>OLV</b> <b>CLV</b> <b>AOLV</b> <b>OLV/PM</b> <b>AOLV/PM</b> <b>CLV/PM</b> <b>EZOLV</b><br>The terminal activates if the monitor value set with H2-26 [Comparator 2 Monitor Selection] is not in the range of the values of H2-27 [Comparator 2 Lower Limit] and H2-28 [Comparator 2 Upper Limit] for the time set with H2-30 [Comparator 2 On-Delay Time].  | 414  |
| 69            | External Power 24V Supply           | <b>V/f</b> <b>CL-V/f</b> <b>OLV</b> <b>CLV</b> <b>AOLV</b> <b>OLV/PM</b> <b>AOLV/PM</b> <b>CLV/PM</b> <b>EZOLV</b><br>The terminal activates when there is an external 24V power supply between terminals PS-AC.<br>ON : An external 24V power supply supplies power.<br>OFF : An external 24V power supply does not supply power.  | 414  |
| 6A            | Data Logger Error                   | <b>V/f</b> <b>CL-V/f</b> <b>OLV</b> <b>CLV</b> <b>AOLV</b> <b>OLV/PM</b> <b>AOLV/PM</b> <b>CLV/PM</b> <b>EZOLV</b><br>The terminal activates when the drive detects a LoG [Com Error / Abnormal SD card].   | 415  |
| 90 - 93       | DWEZ Digital Output 1 to 4          | <b>V/f</b> <b>CL-V/f</b> <b>OLV</b> <b>CLV</b> <b>AOLV</b> <b>OLV/PM</b> <b>AOLV/PM</b> <b>CLV/PM</b> <b>EZOLV</b><br>Sets the DriveWorksEZ digital output. Refer to the DriveWorksEZ online manual for more information.   | 415  |
| A0 to A7      | DWEZ Extended Digital Output 1 to 8 | <b>V/f</b> <b>CL-V/f</b> <b>OLV</b> <b>CLV</b> <b>AOLV</b> <b>OLV/PM</b> <b>AOLV/PM</b> <b>CLV/PM</b> <b>EZOLV</b><br>Sets the digital output for the DriveWorksEZ DO-A3 option card. Refer to the DriveWorksEZ online manual for more information.   | 415  |
| 100 to 1A7    | Inverse output of 0 to A7           | <b>V/f</b> <b>CL-V/f</b> <b>OLV</b> <b>CLV</b> <b>AOLV</b> <b>OLV/PM</b> <b>AOLV/PM</b> <b>CLV/PM</b> <b>EZOLV</b><br>Causes inverse output of the function for the selected MFDO. Uses the last two digits of 1xx to select which function to inversely output.  | 415  |

### ◆ H3: Analog Inputs

| No. (Hex.)       | Name                            | Description   | Default (Range)              | Ref. |
|------------------|---------------------------------|---|------------------------------|------|
| H3-01 (0410)     | Terminal A1 Signal Level Select | <b>V/f</b> <b>CL-V/f</b> <b>OLV</b> <b>CLV</b> <b>AOLV</b> <b>OLV/PM</b> <b>AOLV/PM</b> <b>CLV/PM</b> <b>EZOLV</b><br>Sets the input signal level for MFAI terminal A1.<br>0 : 0 to 10V (Lower Limit at 0)<br>1 : -10 to +10V (Bipolar Reference)<br>2 : 4 to 20 mA<br>3 : 0 to 20 mA | 0<br>(0 - 3)                 | 417  |
| H3-02 (0434)     | Terminal A1 Function Selection  | <b>V/f</b> <b>CL-V/f</b> <b>OLV</b> <b>CLV</b> <b>AOLV</b> <b>OLV/PM</b> <b>AOLV/PM</b> <b>CLV/PM</b> <b>EZOLV</b><br>Sets the function for MFAI terminal A1.   | 0<br>(0 - 32)                | 417  |
| H3-03 (0411) RUN | Terminal A1 Gain Setting        | <b>V/f</b> <b>CL-V/f</b> <b>OLV</b> <b>CLV</b> <b>AOLV</b> <b>OLV/PM</b> <b>AOLV/PM</b> <b>CLV/PM</b> <b>EZOLV</b><br>Sets the gain of the analog signal input to MFAI terminal A1.   | 100.0%<br>(-999.9 - +999.9%) | 417  |
| H3-04 (0412) RUN | Terminal A1 Bias Setting        | <b>V/f</b> <b>CL-V/f</b> <b>OLV</b> <b>CLV</b> <b>AOLV</b> <b>OLV/PM</b> <b>AOLV/PM</b> <b>CLV/PM</b> <b>EZOLV</b><br>Sets the bias of the analog signal input to MFAI terminal A1.   | 0.0%<br>(-999.9 - +999.9%)   | 418  |
| H3-05 (0413)     | Terminal A3 Signal Level Select | <b>V/f</b> <b>CL-V/f</b> <b>OLV</b> <b>CLV</b> <b>AOLV</b> <b>OLV/PM</b> <b>AOLV/PM</b> <b>CLV/PM</b> <b>EZOLV</b><br>Sets the input signal level for MFAI terminal A3.<br>0 : 0 to 10V (Lower Limit at 0)<br>1 : -10 to +10V (Bipolar Reference)<br>2 : 4 to 20 mA<br>3 : 0 to 20 mA | 0<br>(0 - 3)                 | 418  |
| H3-06 (0414)     | Terminal A3 Function Selection  | <b>V/f</b> <b>CL-V/f</b> <b>OLV</b> <b>CLV</b> <b>AOLV</b> <b>OLV/PM</b> <b>AOLV/PM</b> <b>CLV/PM</b> <b>EZOLV</b><br>Sets the function for MFAI terminal A3.   | 2<br>(0 - 32)                | 418  |

## 1.10 H: Terminal Functions

| No. (Hex.)       | Name                             | Description   | Default (Range)              | Ref. |
|------------------|----------------------------------|---|------------------------------|------|
| H3-07 (0415) RUN | Terminal A3 Gain Setting         | <b>V/f</b> <b>CL-V/f</b> <b>OLV</b> <b>CLV</b> <b>AOLV</b> <b>OLV/PM</b> <b>AOLV/PM</b> <b>CLV/PM</b> <b>EZOLV</b><br>Sets the gain of the analog signal input to MFAI terminal A3.   | 100.0%<br>(-999.9 - +999.9%) | 419  |
| H3-08 (0416) RUN | Terminal A3 Bias Setting         | <b>V/f</b> <b>CL-V/f</b> <b>OLV</b> <b>CLV</b> <b>AOLV</b> <b>OLV/PM</b> <b>AOLV/PM</b> <b>CLV/PM</b> <b>EZOLV</b><br>Sets the bias of the analog signal input to MFAI terminal A3.   | 0.0%<br>(-999.9 - +999.9%)   | 419  |
| H3-09 (0417)     | Terminal A2 Signal Level Select  | <b>V/f</b> <b>CL-V/f</b> <b>OLV</b> <b>CLV</b> <b>AOLV</b> <b>OLV/PM</b> <b>AOLV/PM</b> <b>CLV/PM</b> <b>EZOLV</b><br>Sets the input signal level for MFAI terminal A2.<br>0 : 0-10V (LowLim=0)<br>1 : -10 to +10V (Bipolar Reference)<br>2 : 4 to 20 mA<br>3 : 0 to 20 mA  | 2<br>(0 - 3)                 | 419  |
| H3-10 (0418)     | Terminal A2 Function Selection   | <b>V/f</b> <b>CL-V/f</b> <b>OLV</b> <b>CLV</b> <b>AOLV</b> <b>OLV/PM</b> <b>AOLV/PM</b> <b>CLV/PM</b> <b>EZOLV</b><br>Sets the function for MFAI terminal A2.   | 0<br>(0 - 32)                | 419  |
| H3-11 (0419) RUN | Terminal A2 Gain Setting         | <b>V/f</b> <b>CL-V/f</b> <b>OLV</b> <b>CLV</b> <b>AOLV</b> <b>OLV/PM</b> <b>AOLV/PM</b> <b>CLV/PM</b> <b>EZOLV</b><br>Sets the gain of the analog signal input to MFAI terminal A2.   | 100.0%<br>(-999.9 - +999.9%) | 420  |
| H3-12 (041A) RUN | Terminal A2 Bias Setting         | <b>V/f</b> <b>CL-V/f</b> <b>OLV</b> <b>CLV</b> <b>AOLV</b> <b>OLV/PM</b> <b>AOLV/PM</b> <b>CLV/PM</b> <b>EZOLV</b><br>Sets the bias of the analog signal input to MFAI terminal A2.   | 0.0%<br>(-999.9 - +999.9%)   | 420  |
| H3-13 (041B)     | Analog Input FilterTime Constant | <b>V/f</b> <b>CL-V/f</b> <b>OLV</b> <b>CLV</b> <b>AOLV</b> <b>OLV/PM</b> <b>AOLV/PM</b> <b>CLV/PM</b> <b>EZOLV</b><br>Sets the time constant for primary delay filters on MFAI terminals.   | 0.03 s<br>(0.00 - 2.00 s)    | 420  |
| H3-14 (041C)     | Analog Input Terminal Enable Sel | <b>V/f</b> <b>CL-V/f</b> <b>OLV</b> <b>CLV</b> <b>AOLV</b> <b>OLV/PM</b> <b>AOLV/PM</b> <b>CLV/PM</b> <b>EZOLV</b><br>Sets the enabled terminal or terminals when $H1-xx = C$ [MFDI Function Select = Analog Terminal Enable Selection] is ON.<br>1 : Terminal A1 only<br>2 : Terminal A2 only<br>3 : Terminals A1 and A2<br>4 : Terminal A3 only<br>5 : Terminals A1 and A3<br>6 : Terminals A2 and A3<br>7 : Terminals A1, A2, and A3 | 7<br>(1 - 7)                 | 420  |
| H3-16 (02F0)     | Terminal A1 Offset               | <b>V/f</b> <b>CL-V/f</b> <b>OLV</b> <b>CLV</b> <b>AOLV</b> <b>OLV/PM</b> <b>AOLV/PM</b> <b>CLV/PM</b> <b>EZOLV</b><br>Sets the offset level for analog signals input to terminal A1. Usually it is not necessary to change this setting.  | 0<br>(-500 - +500)           | 421  |
| H3-17 (02F1)     | Terminal A2 Offset               | <b>V/f</b> <b>CL-V/f</b> <b>OLV</b> <b>CLV</b> <b>AOLV</b> <b>OLV/PM</b> <b>AOLV/PM</b> <b>CLV/PM</b> <b>EZOLV</b><br>Sets the offset level for analog signals input to terminal A2. Usually it is not necessary to change this setting.  | 0<br>(-500 - +500)           | 421  |
| H3-18 (02F2)     | Terminal A3 Offset               | <b>V/f</b> <b>CL-V/f</b> <b>OLV</b> <b>CLV</b> <b>AOLV</b> <b>OLV/PM</b> <b>AOLV/PM</b> <b>CLV/PM</b> <b>EZOLV</b><br>Sets the offset level for analog signals input to terminal A3. Usually it is not necessary to change this setting.  | 0<br>(-500 - +500)           | 421  |
| H3-40 (0B5C)     | Mbus Reg 15C1h Input Function    | <b>V/f</b> <b>CL-V/f</b> <b>OLV</b> <b>CLV</b> <b>AOLV</b> <b>OLV/PM</b> <b>AOLV/PM</b> <b>CLV/PM</b> <b>EZOLV</b><br>Sets the MEMOBUS AI1 function.  | F<br>(4 - 2F)                | 421  |
| H3-41 (0B5F)     | Mbus Reg 15C2h Input Function    | <b>V/f</b> <b>CL-V/f</b> <b>OLV</b> <b>CLV</b> <b>AOLV</b> <b>OLV/PM</b> <b>AOLV/PM</b> <b>CLV/PM</b> <b>EZOLV</b><br>Sets the MEMOBUS AI2 function.  | F<br>(4 - 2F)                | 421  |
| H3-42 (0B62)     | Mbus Reg 15C3h Input Function    | <b>V/f</b> <b>CL-V/f</b> <b>OLV</b> <b>CLV</b> <b>AOLV</b> <b>OLV/PM</b> <b>AOLV/PM</b> <b>CLV/PM</b> <b>EZOLV</b><br>Sets the MEMOBUS AI3 function.  | F<br>(4 - 2F)                | 422  |
| H3-43 (117F)     | Mbus Reg Inputs FilterTime Const | <b>V/f</b> <b>CL-V/f</b> <b>OLV</b> <b>CLV</b> <b>AOLV</b> <b>OLV/PM</b> <b>AOLV/PM</b> <b>CLV/PM</b> <b>EZOLV</b><br>Sets the time constant to apply a primary delay filter to the MEMOBUS analog input terminal.  | 0.00 s<br>(0.00 - 2.00 s)    | 422  |

### ■ H3-xx: MFAI Setting Values

| Setting Value | Function            | Description  | Ref. |
|---------------|---------------------|--|------|
| 0             | Frequency Reference | <b>V/f</b> <b>CL-V/f</b> <b>OLV</b> <b>CLV</b> <b>AOLV</b> <b>OLV/PM</b> <b>AOLV/PM</b> <b>CLV/PM</b> <b>EZOLV</b><br>The input value from the MFAI terminal set with this function becomes the master frequency reference.          | 422  |
| 1             | Frequency Gain      | <b>V/f</b> <b>CL-V/f</b> <b>OLV</b> <b>CLV</b> <b>AOLV</b> <b>OLV/PM</b> <b>AOLV/PM</b> <b>CLV/PM</b> <b>EZOLV</b><br>The drive multiplies the analog frequency reference with the input value from the MFAI set with this function. | 422  |

| Setting Value | Function                        | Description  | Ref. |
|---------------|---------------------------------|--|------|
| 2             | Auxiliary Frequency Reference 1 | <p><b>V/f</b> <b>CL-V/f</b> <b>OLV</b> <b>CLV</b> <b>AOLV</b> <b>OLV/PM</b> <b>AOLV/PM</b> <b>CLV/PM</b> <b>EZOLV</b></p> <p>Sets Reference 2 through multi-step speed reference to enable the command reference (Auxiliary Frequency Reference 1) from the analog input terminal set here. This value is a percentage where the maximum output frequency setting is a setting value of 100%.</p> <p><b>Note:</b><br/>                     Parameter <i>A1-02 [Control Method Selection]</i> selects which parameter is the maximum output frequency.<br/>                     • <i>A1-02 ≠ 8 [EZOLV]: E1-04 [Maximum Output Frequency]</i><br/>                     • <i>A1-02 = 8: E9-02 [Maximum Speed]</i></p> | 422  |
| 3             | Auxiliary Frequency Reference 2 | <p><b>V/f</b> <b>CL-V/f</b> <b>OLV</b> <b>CLV</b> <b>AOLV</b> <b>OLV/PM</b> <b>AOLV/PM</b> <b>CLV/PM</b> <b>EZOLV</b></p> <p>Sets Reference 3 through multi-step speed reference to enable the command reference (Auxiliary Frequency Reference 2) from the analog input terminal set here. This value is a percentage where Maximum Output Frequency setting is a setting value of 100%.</p> <p><b>Note:</b><br/>                     Parameter <i>A1-02 [Control Method Selection]</i> selects which parameter is the maximum output frequency.<br/>                     • <i>A1-02 ≠ 8 [EZOLV]: E1-04 [Maximum Output Frequency]</i><br/>                     • <i>A1-02 = 8: E9-02 [Maximum Speed]</i></p>     | 423  |
| 4             | Output Voltage Bias             | <p><b>V/f</b> <b>CL-V/f</b> <b>OLV</b> <b>CLV</b> <b>AOLV</b> <b>OLV/PM</b> <b>AOLV/PM</b> <b>CLV/PM</b> <b>EZOLV</b></p> <p>Set this parameter to input a bias signal and amplify the output voltage.</p>   | 423  |
| 5             | Accel/Decel Time Gain           | <p><b>V/f</b> <b>CL-V/f</b> <b>OLV</b> <b>CLV</b> <b>AOLV</b> <b>OLV/PM</b> <b>AOLV/PM</b> <b>CLV/PM</b> <b>EZOLV</b></p> <p>Enters a signal to adjust the gain used for <i>C1-01 to C1-08 [Accel &amp; Decel Time 1 to 4]</i> and <i>C1-09 [Fast Stop Time]</i> if the full scale analog signal (10 V or 20 mA) is 100%.</p>  | 423  |
| 6             | DC Injection Braking Current    | <p><b>V/f</b> <b>CL-V/f</b> <b>OLV</b> <b>CLV</b> <b>AOLV</b> <b>OLV/PM</b> <b>AOLV/PM</b> <b>CLV/PM</b> <b>EZOLV</b></p> <p>Enters a signal to adjust the current level used for DC Injection Braking if the drive rated output current is 100%.</p>  | 423  |
| 7             | Torque Detection Level          | <p><b>V/f</b> <b>CL-V/f</b> <b>OLV</b> <b>CLV</b> <b>AOLV</b> <b>OLV/PM</b> <b>AOLV/PM</b> <b>CLV/PM</b> <b>EZOLV</b></p> <p>Enters a signal to adjust the overtorque/undertorque detection level.</p> <p><b>Note:</b><br/>                     Use this function with <i>L6-01 [Torque Detection Selection 1]</i>. This parameter functions as an alternative to <i>L6-02 [Torque Detection Level 1]</i>.</p>   | 424  |
| 8             | Stall Prevent Level during Run  | <p><b>V/f</b> <b>CL-V/f</b> <b>OLV</b> <b>CLV</b> <b>AOLV</b> <b>OLV/PM</b> <b>AOLV/PM</b> <b>CLV/PM</b> <b>EZOLV</b></p> <p>Enters a signal to adjust the stall prevention level during run if the drive rated current is 100%.</p>   | 424  |
| 9             | Output Frequency Lower Limit    | <p><b>V/f</b> <b>CL-V/f</b> <b>OLV</b> <b>CLV</b> <b>AOLV</b> <b>OLV/PM</b> <b>AOLV/PM</b> <b>CLV/PM</b> <b>EZOLV</b></p> <p>Enters a signal to adjust the output frequency lower limit level as a percentage of the maximum output frequency.</p> <p><b>Note:</b><br/>                     Parameter <i>A1-02 [Control Method Selection]</i> selects which parameter is the maximum output frequency.<br/>                     • <i>A1-02 ≠ 8 [EZOLV]: E1-04 [Maximum Output Frequency]</i><br/>                     • <i>A1-02 = 8: E9-02 [Maximum Speed]</i></p>  | 424  |
| B             | PID Feedback                    | <p><b>V/f</b> <b>CL-V/f</b> <b>OLV</b> <b>CLV</b> <b>AOLV</b> <b>OLV/PM</b> <b>AOLV/PM</b> <b>CLV/PM</b> <b>EZOLV</b></p> <p>Enter the PID feedback value as a percentage of the maximum output frequency.</p> <p><b>Note:</b><br/>                     Parameter <i>A1-02 [Control Method Selection]</i> selects which parameter is the maximum output frequency.<br/>                     • <i>A1-02 ≠ 8 [EZOLV]: E1-04 [Maximum Output Frequency]</i><br/>                     • <i>A1-02 = 8: E9-02 [Maximum Speed]</i></p>  | 424  |
| C             | PID Setpoint                    | <p><b>V/f</b> <b>CL-V/f</b> <b>OLV</b> <b>CLV</b> <b>AOLV</b> <b>OLV/PM</b> <b>AOLV/PM</b> <b>CLV/PM</b> <b>EZOLV</b></p> <p>Enters the PID setpoint as a percentage of the maximum output frequency.</p> <p><b>Note:</b><br/>                     Parameter <i>A1-02 [Control Method Selection]</i> selects which parameter is the maximum output frequency.<br/>                     • <i>A1-02 ≠ 8 [EZOLV]: E1-04 [Maximum Output Frequency]</i><br/>                     • <i>A1-02 = 8: E9-02 [Maximum Speed]</i></p>   | 425  |
| D             | Frequency Bias                  | <p><b>V/f</b> <b>CL-V/f</b> <b>OLV</b> <b>CLV</b> <b>AOLV</b> <b>OLV/PM</b> <b>AOLV/PM</b> <b>CLV/PM</b> <b>EZOLV</b></p> <p>Enters the bias value added to the frequency reference as a percentage of the maximum output frequency.</p> <p><b>Note:</b><br/>                     Parameter <i>A1-02 [Control Method Selection]</i> selects which parameter is the maximum output frequency.<br/>                     • <i>A1-02 ≠ 8 [EZOLV]: E1-04 [Maximum Output Frequency]</i><br/>                     • <i>A1-02 = 8: E9-02 [Maximum Speed]</i></p>  | 425  |
| E             | Motor Temperature (PTC Input)   | <p><b>V/f</b> <b>CL-V/f</b> <b>OLV</b> <b>CLV</b> <b>AOLV</b> <b>OLV/PM</b> <b>AOLV/PM</b> <b>CLV/PM</b> <b>EZOLV</b></p> <p>Uses the motor Positive Temperature Coefficient (PTC) thermistor to prevent heat damage to the motor as a percentage of the current value when the 10 V analog signal is input.</p>   | 425  |
| F             | Not Used                        | <p><b>V/f</b> <b>CL-V/f</b> <b>OLV</b> <b>CLV</b> <b>AOLV</b> <b>OLV/PM</b> <b>AOLV/PM</b> <b>CLV/PM</b> <b>EZOLV</b></p> <p>Use this setting for unused terminals or to use terminals in through mode.</p>  | 425  |
| 10            | Forward Torque Limit            | <p><b>V/f</b> <b>CL-V/f</b> <b>OLV</b> <b>CLV</b> <b>AOLV</b> <b>OLV/PM</b> <b>AOLV/PM</b> <b>CLV/PM</b> <b>EZOLV</b></p> <p>Enters the forward torque limit if the motor rated torque is 100%.</p>  | 425  |
| 11            | Reverse Torque Limit            | <p><b>V/f</b> <b>CL-V/f</b> <b>OLV</b> <b>CLV</b> <b>AOLV</b> <b>OLV/PM</b> <b>AOLV/PM</b> <b>CLV/PM</b> <b>EZOLV</b></p> <p>Enters the load torque limit if the motor rated torque is 100%.</p>   | 426  |

## 1.10 H: Terminal Functions

| Setting Value | Function                        | Description  | Ref. |
|---------------|---------------------------------|--|------|
| 12            | Regenerative Torque Limit       | <b>V/f</b> <b>CL-V/f</b> <b>OLV</b> <b>CLV</b> <b>AOLV</b> <b>OLV/PM</b> <b>AOLV/PM</b> <b>CLV/PM</b> <b>EZOLV</b><br>Enters the regenerative torque limit if the motor rated torque is 100%.  | 427  |
| 13            | Torque Reference / Torque Limit | <b>V/f</b> <b>CL-V/f</b> <b>OLV</b> <b>CLV</b> <b>AOLV</b> <b>OLV/PM</b> <b>AOLV/PM</b> <b>CLV/PM</b> <b>EZOLV</b><br>Enters the torque reference if the motor rated torque is 100%. This setting is the torque limit for speed control.                             | 427  |
| 14            | Torque Compensation             | <b>V/f</b> <b>CL-V/f</b> <b>OLV</b> <b>CLV</b> <b>AOLV</b> <b>OLV/PM</b> <b>AOLV/PM</b> <b>CLV/PM</b> <b>EZOLV</b><br>Enters the torque compensation value if the motor rated torque is 100%.  | 427  |
| 15            | General Torque Limit            | <b>V/f</b> <b>CL-V/f</b> <b>OLV</b> <b>CLV</b> <b>AOLV</b> <b>OLV/PM</b> <b>AOLV/PM</b> <b>CLV/PM</b> <b>EZOLV</b><br>Enters the torque limit that is the same for all quadrants for forward, reverse, and regenerative operation if the motor rated torque is 100%. | 427  |
| 16            | PID DifferentialFdbk            | <b>V/f</b> <b>CL-V/f</b> <b>OLV</b> <b>CLV</b> <b>AOLV</b> <b>OLV/PM</b> <b>AOLV/PM</b> <b>CLV/PM</b> <b>EZOLV</b><br>Enters the PID differential feedback value if the full scale analog signal (10 V or 20 mA) is 100%.  | 427  |
| 1F            | Not Used                        | <b>V/f</b> <b>CL-V/f</b> <b>OLV</b> <b>CLV</b> <b>AOLV</b> <b>OLV/PM</b> <b>AOLV/PM</b> <b>CLV/PM</b> <b>EZOLV</b><br>Use this setting for unused terminals or to use terminals in through mode.   | 427  |
| 30            | DWEZ Analog Input 1             | <b>V/f</b> <b>CL-V/f</b> <b>OLV</b> <b>CLV</b> <b>AOLV</b> <b>OLV/PM</b> <b>AOLV/PM</b> <b>CLV/PM</b> <b>EZOLV</b><br>Use with DriveWorksEZ. Refer to the DriveWorksEZ online manual for more information.   | 427  |
| 31            | DWEZ Analog Input 2             | <b>V/f</b> <b>CL-V/f</b> <b>OLV</b> <b>CLV</b> <b>AOLV</b> <b>OLV/PM</b> <b>AOLV/PM</b> <b>CLV/PM</b> <b>EZOLV</b><br>Use with DriveWorksEZ. Refer to the DriveWorksEZ online manual for more information.   | 427  |
| 32            | DWEZ Analog Input 3             | <b>V/f</b> <b>CL-V/f</b> <b>OLV</b> <b>CLV</b> <b>AOLV</b> <b>OLV/PM</b> <b>AOLV/PM</b> <b>CLV/PM</b> <b>EZOLV</b><br>Use with DriveWorksEZ. Refer to the DriveWorksEZ online manual for more information.   | 428  |

### ◆ H4: Analog Outputs

| No. (Hex.)       | Name                             | Description  | Default (Range)              | Ref. |
|------------------|----------------------------------|--|------------------------------|------|
| H4-01 (041D)     | Terminal FM Analog Output Select | <b>V/f</b> <b>CL-V/f</b> <b>OLV</b> <b>CLV</b> <b>AOLV</b> <b>OLV/PM</b> <b>AOLV/PM</b> <b>CLV/PM</b> <b>EZOLV</b><br>Sets the monitor number to send from MFAO terminal FM.<br>Set the <i>x-xx</i> part of the <i>Ux-xx</i> [Monitor]. For example, set <i>H4-01 = 102</i> to monitor <i>U1-02</i> [Output Frequency].                            | 102<br>(000 - 999)           | 429  |
| H4-02 (041E) RUN | Terminal FM Analog Output Gain   | <b>V/f</b> <b>CL-V/f</b> <b>OLV</b> <b>CLV</b> <b>AOLV</b> <b>OLV/PM</b> <b>AOLV/PM</b> <b>CLV/PM</b> <b>EZOLV</b><br>Sets the gain of the monitor signal that is sent from MFAO terminal FM.<br>Sets the analog signal output level from the terminal FM at 10 V or 20 mA as 100% when an output for monitoring items is 100%.                    | 100.0%<br>(-999.9 - +999.9%) | 429  |
| H4-03 (041F) RUN | Terminal FM Analog Output Bias   | <b>V/f</b> <b>CL-V/f</b> <b>OLV</b> <b>CLV</b> <b>AOLV</b> <b>OLV/PM</b> <b>AOLV/PM</b> <b>CLV/PM</b> <b>EZOLV</b><br>Sets the bias of the monitor signal that is sent from MFAO terminal FM.<br>Set the level of the analog signal sent from terminal FM at 10 V or 20 mA as 100% when an output for monitoring items is 0%.                      | 0.0%<br>(-999.9 - +999.9%)   | 430  |
| H4-04 (0420)     | Terminal AM Analog Output Select | <b>V/f</b> <b>CL-V/f</b> <b>OLV</b> <b>CLV</b> <b>AOLV</b> <b>OLV/PM</b> <b>AOLV/PM</b> <b>CLV/PM</b> <b>EZOLV</b><br>Sets the monitoring number to be output from the MFAO terminal AM.<br>Set the <i>x-xx</i> part of the <i>Ux-xx</i> [Monitor]. For example, set <i>H4-04 = 103</i> to monitor <i>U1-03</i> [Output Current].                  | 103<br>(000 - 999)           | 430  |
| H4-05 (0421) RUN | Terminal AM Analog Output Gain   | <b>V/f</b> <b>CL-V/f</b> <b>OLV</b> <b>CLV</b> <b>AOLV</b> <b>OLV/PM</b> <b>AOLV/PM</b> <b>CLV/PM</b> <b>EZOLV</b><br>Sets the gain of the monitor signal that is sent from MFAO terminal AM.<br>When an output for monitoring items is 0%, this parameter sets the analog signal output level from the AM terminal at 10 V or 20 mA as 100%.      | 50.0%<br>(-999.9 - +999.9%)  | 430  |
| H4-06 (0422) RUN | Terminal AM Analog Output Bias   | <b>V/f</b> <b>CL-V/f</b> <b>OLV</b> <b>CLV</b> <b>AOLV</b> <b>OLV/PM</b> <b>AOLV/PM</b> <b>CLV/PM</b> <b>EZOLV</b><br>Sets the bias of the monitor signal that is sent from MFAO terminal AM.<br>When an output for monitoring items is 0%, this parameter sets the analog signal output level from the AM terminal at 10 V or 20 mA as 0%.        | 0.0%<br>(-999.9 - +999.9%)   | 430  |
| H4-07 (0423)     | Terminal FM Signal Level Select  | <b>V/f</b> <b>CL-V/f</b> <b>OLV</b> <b>CLV</b> <b>AOLV</b> <b>OLV/PM</b> <b>AOLV/PM</b> <b>CLV/PM</b> <b>EZOLV</b><br>Sets the MFAO terminal FM output signal level.<br><b>Note:</b><br>Set jumper S5 on the control circuit terminal block accordingly when changing these parameters.<br>0 : 0 to 10 Vdc<br>1 : -10 to +10 Vdc<br>2 : 4 to 20 mA | 0<br>(0 - 2)                 | 430  |



| No. (Hex.)   | Name                            | Description   | Default (Range)               | Ref. |
|--------------|---------------------------------|---|-------------------------------|------|
| H4-08 (0424) | Terminal AM Signal Level Select | <p><b>V/f</b> <b>CL-V/f</b> <b>OLV</b> <b>CLV</b> <b>AOLV</b> <b>OLV/PM</b> <b>AOLV/PM</b> <b>CLV/PM</b> <b>EZOLV</b></p> <p>Sets the MFAO terminal AM output signal level.</p> <p><b>Note:</b><br/>Set jumper S5 on the control circuit terminal block accordingly when changing these parameters.<br/>0 : 0 to 10 Vdc<br/>1 : -10 to +10 Vdc<br/>2 : 4 to 20 mA</p> | 0<br>(0 - 2)                  | 431  |
| H4-20 (0B53) | Analog Power Monitor 100% Level | <p><b>V/f</b> <b>CL-V/f</b> <b>OLV</b> <b>CLV</b> <b>AOLV</b> <b>OLV/PM</b> <b>AOLV/PM</b> <b>CLV/PM</b> <b>EZOLV</b></p> <p>Sets the level at 10 V when <i>U1-08 [Output Power]</i> is set for analog output.</p>  | 0.00 kW<br>(0.00 - 650.00 kW) | 431  |

## ◆ H5: Modbus Communication

| No. (Hex.)   | Name                            | Description  | Default (Range)         | Ref. |
|--------------|---------------------------------|--|-------------------------|------|
| H5-01 (0425) | Slave address                   | <p><b>V/f</b> <b>CL-V/f</b> <b>OLV</b> <b>CLV</b> <b>AOLV</b> <b>OLV/PM</b> <b>AOLV/PM</b> <b>CLV/PM</b> <b>EZOLV</b></p> <p>Sets the communication slave address for drives.</p> <p><b>Note:</b><br/>• Restart the drive after changing the parameter setting.<br/>• Setting 0 will not let the drive respond to MEMOBUS/Modbus communications.</p>   | 1FH<br>(0 - FFH)        | 431  |
| H5-02 (0426) | Communication Speed Selection   | <p><b>V/f</b> <b>CL-V/f</b> <b>OLV</b> <b>CLV</b> <b>AOLV</b> <b>OLV/PM</b> <b>AOLV/PM</b> <b>CLV/PM</b> <b>EZOLV</b></p> <p>Sets the communications speed for MEMOBUS/Modbus communications.</p> <p><b>Note:</b><br/>Restart the drive after changing the parameter setting.<br/>0 : 1200 bps<br/>1 : 2400 bps<br/>2 : 4800 bps<br/>3 : 9600 bps<br/>4 : 19200 bps<br/>5 : 38400 bps<br/>6 : 57600 bps<br/>7 : 76800 bps<br/>8 : 115200 bps</p> | 3<br>(0 - 8)            | 432  |
| H5-03 (0427) | Communication Parity Selection  | <p><b>V/f</b> <b>CL-V/f</b> <b>OLV</b> <b>CLV</b> <b>AOLV</b> <b>OLV/PM</b> <b>AOLV/PM</b> <b>CLV/PM</b> <b>EZOLV</b></p> <p>Sets the communications parity used for MEMOBUS/Modbus communications.</p> <p><b>Note:</b><br/>Restart the drive after changing the parameter setting.<br/>0 : No parity<br/>1 : Even parity<br/>2 : Odd parity</p>   | 0<br>(0 - 2)            | 432  |
| H5-04 (0428) | Communication Error Stop Method | <p><b>V/f</b> <b>CL-V/f</b> <b>OLV</b> <b>CLV</b> <b>AOLV</b> <b>OLV/PM</b> <b>AOLV/PM</b> <b>CLV/PM</b> <b>EZOLV</b></p> <p>Sets the motor Stopping Method when the drive detects <i>CE [MEMOBUS/Modbus Communication Err]</i> issues.</p> <p>0 : Ramp to Stop<br/>1 : Coast to Stop<br/>2 : Fast Stop<br/>3 : Alarm Only</p>   | 3<br>(0 - 3)            | 432  |
| H5-05 (0429) | Comm Fault Detection Selection  | <p><b>V/f</b> <b>CL-V/f</b> <b>OLV</b> <b>CLV</b> <b>AOLV</b> <b>OLV/PM</b> <b>AOLV/PM</b> <b>CLV/PM</b> <b>EZOLV</b></p> <p>Sets the function that detects <i>CE [Modbus Communication Error]</i> issues during MEMOBUS/Modbus communications.</p> <p>0 : Disabled<br/>1 : Enabled</p>  | 1<br>(0, 1)             | 433  |
| H5-06 (042A) | Drive Transmit Wait Time        | <p><b>V/f</b> <b>CL-V/f</b> <b>OLV</b> <b>CLV</b> <b>AOLV</b> <b>OLV/PM</b> <b>AOLV/PM</b> <b>CLV/PM</b> <b>EZOLV</b></p> <p>Sets the time to wait to send a response message after the drive receives a command message from the master.</p> <p><b>Note:</b><br/>Restart the drive after changing the parameter setting.</p>  | 5 ms<br>(0 - 65 ms)     | 433  |
| H5-09 (0435) | CE Detection Time               | <p><b>V/f</b> <b>CL-V/f</b> <b>OLV</b> <b>CLV</b> <b>AOLV</b> <b>OLV/PM</b> <b>AOLV/PM</b> <b>CLV/PM</b> <b>EZOLV</b></p> <p>Sets the detection time for <i>CE [Modbus Communication Error]</i> issues when communication stops.</p>   | 2.0 s<br>(0.0 - 10.0 s) | 433  |

## 1.10 H: Terminal Functions

| No. (Hex.)          | Name                             | Description   | Default (Range)                  | Ref. |
|---------------------|----------------------------------|---|----------------------------------|------|
| H5-10 (0436)        | Modbus Register 0025H Unit Sel   | <b>V/f</b> <b>CL-V/f</b> <b>OLV</b> <b>CLV</b> <b>AOLV</b> <b>OLV/PM</b> <b>AOLV/PM</b> <b>CLV/PM</b> <b>EZOLV</b><br>Sets the unit of measure used for the MEMOBUS/Modbus communications monitor register 0025H (output voltage reference monitor).<br>0 : 0.1 V units<br>1 : 1 V units  | 0<br>(0, 1)                      | 433  |
| H5-11 (043C)        | Comm ENTER Command Mode          | <b>V/f</b> <b>CL-V/f</b> <b>OLV</b> <b>CLV</b> <b>AOLV</b> <b>OLV/PM</b> <b>AOLV/PM</b> <b>CLV/PM</b> <b>EZOLV</b><br>Sets the function to make the Enter command necessary to change parameters through MEMOBUS/Modbus communications.<br>0 : ENTER Command Required<br>1 : ENTER Command Not Required   | 0<br>(0, 1)                      | 433  |
| H5-12 (043D)        | Run Command Method Selection     | <b>V/f</b> <b>CL-V/f</b> <b>OLV</b> <b>CLV</b> <b>AOLV</b> <b>OLV/PM</b> <b>AOLV/PM</b> <b>CLV/PM</b> <b>EZOLV</b><br>Sets the input method for the Run command when <i>b1-02 = 2</i> [Run Command Selection 1 = Memobus/Modbus Communications] or <i>b1-16 = 2</i> [Run Command Selection 2 = Memobus/Modbus Communications].<br>0 : FWD/Stop, REV/Stop<br>1 : Run/Stop, FWD/REV | 0<br>(0, 1)                      | 434  |
| H5-17 (11A1) Expert | ENTER command response @CPU BUSY | <b>V/f</b> <b>CL-V/f</b> <b>OLV</b> <b>CLV</b> <b>AOLV</b> <b>OLV/PM</b> <b>AOLV/PM</b> <b>CLV/PM</b> <b>EZOLV</b><br>Sets operation when the EEPROM write command is sent without EEPROM write available. Usually it is not necessary to change this setting.<br>0 : Ignore Command(No ROM/RAM Write)<br>1 : Write to RAM Only   | 0<br>(0, 1)                      | 434  |
| H5-18 (11A2)        | Motor Speed Filter over Comms    | <b>V/f</b> <b>CL-V/f</b> <b>OLV</b> <b>CLV</b> <b>AOLV</b> <b>OLV/PM</b> <b>AOLV/PM</b> <b>CLV/PM</b> <b>EZOLV</b><br>Sets the filter time constant used when monitoring motor speed during MEMOBUS/Modbus communications or with a communication option.   | 0 ms<br>(0 - 100 ms)             | 434  |
| H5-20 (0B57)        | Communication Parameters Reload  | <b>V/f</b> <b>CL-V/f</b> <b>OLV</b> <b>CLV</b> <b>AOLV</b> <b>OLV/PM</b> <b>AOLV/PM</b> <b>CLV/PM</b> <b>EZOLV</b><br>Sets the function to immediately enable updated MEMOBUS/Modbus communications parameters.<br>0 : Reload at Next Power Cycle<br>1 : Reload Now   | 0<br>(0, 1)                      | 434  |
| H5-22 (11CF)        | Speed Search from MEMOBUS        | <b>V/f</b> <b>CL-V/f</b> <b>OLV</b> <b>CLV</b> <b>AOLV</b> <b>OLV/PM</b> <b>AOLV/PM</b> <b>CLV/PM</b> <b>EZOLV</b><br>Enables the MEMOBUS/Modbus communication register Speed Search function (bit0 of 15DFH).<br>0 : No<br>1 : Yes   | 0<br>(0, 1)                      | 435  |
| H5-25 (1589) RUN    | Function 5A Register 1 Selection | <b>V/f</b> <b>CL-V/f</b> <b>OLV</b> <b>CLV</b> <b>AOLV</b> <b>OLV/PM</b> <b>AOLV/PM</b> <b>CLV/PM</b> <b>EZOLV</b><br>Returns the contents of the specified MEMOBUS/Modbus communications register when responding to the master device.  | 0044H (U1-05)<br>(0000H - FFFFH) | 435  |
| H5-26 (158A) RUN    | Function 5A Register 2 Selection | <b>V/f</b> <b>CL-V/f</b> <b>OLV</b> <b>CLV</b> <b>AOLV</b> <b>OLV/PM</b> <b>AOLV/PM</b> <b>CLV/PM</b> <b>EZOLV</b><br>Returns the contents of the specified MEMOBUS/Modbus communications register when responding to the master device.  | 0045H (U1-06)<br>(0000H - FFFFH) | 435  |
| H5-27 (158B) RUN    | Function 5A Register 3 Selection | <b>V/f</b> <b>CL-V/f</b> <b>OLV</b> <b>CLV</b> <b>AOLV</b> <b>OLV/PM</b> <b>AOLV/PM</b> <b>CLV/PM</b> <b>EZOLV</b><br>Returns the contents of the specified MEMOBUS/Modbus communications register when responding to the master device.  | 0042H (U1-03)<br>(0000H - FFFFH) | 435  |
| H5-28 (158C) RUN    | Function 5A Register 4 Selection | <b>V/f</b> <b>CL-V/f</b> <b>OLV</b> <b>CLV</b> <b>AOLV</b> <b>OLV/PM</b> <b>AOLV/PM</b> <b>CLV/PM</b> <b>EZOLV</b><br>Returns the contents of the specified MEMOBUS/Modbus communications register when responding to the master device.  | 0049H (U1-10)<br>(0000H - FFFFH) | 435  |

### ◆ H6: Pulse Train Input/Output

| No. (Hex.)       | Name                             | Description   | Default (Range)             | Ref. |
|------------------|----------------------------------|---|-----------------------------|------|
| H6-01 (042C)     | Terminal RP Pulse Train Function | <b>V/f</b> <b>CL-V/f</b> <b>OLV</b> <b>CLV</b> <b>AOLV</b> <b>OLV/PM</b> <b>AOLV/PM</b> <b>CLV/PM</b> <b>EZOLV</b><br>Sets the function for pulse train input terminal RP.<br>0 : Frequency reference<br>1 : PID Feedback Value<br>2 : PID Setpoint<br>3 : Speed Feedback (V/F Control) | 0<br>(0 - 3)                | 436  |
| H6-02 (042D) RUN | Terminal RP Frequency Scaling    | <b>V/f</b> <b>CL-V/f</b> <b>OLV</b> <b>CLV</b> <b>AOLV</b> <b>OLV/PM</b> <b>AOLV/PM</b> <b>CLV/PM</b> <b>EZOLV</b><br>Sets the frequency of the pulse train input signal used when the item selected with <i>H6-01</i> [Terminal RP Pulse Train Function] is input at 100%.             | 1440 Hz<br>(100 - 32000 Hz) | 437  |

| No. (Hex.)       | Name                            | Description   | Default (Range)   | Ref. |
|------------------|---------------------------------|---|---|------|
| H6-03 (042E) RUN | Terminal RP Function Gain       | <b>V/f</b> <b>CL-V/f</b> <b>OLV</b> <b>CLV</b> <b>AOLV</b> <b>OLV/PM</b> <b>AOLV/PM</b> <b>CLV/PM</b> <b>EZOLV</b><br>Sets the gain used when the function in H6-01 [Terminal RP Pulse Train Function] is input to terminal RP.   | 100.0%<br>(0.0 - 1000.0%)   | 437  |
| H6-04 (042F) RUN | Terminal RP Function Bias       | <b>V/f</b> <b>CL-V/f</b> <b>OLV</b> <b>CLV</b> <b>AOLV</b> <b>OLV/PM</b> <b>AOLV/PM</b> <b>CLV/PM</b> <b>EZOLV</b><br>Sets the bias used when the function in H6-01 [Terminal RP Pulse Train Function] is input to terminal RP. Sets a value at the time when the pulse train is 0 Hz.  | 0.0%<br>(-100.0 - 100.0%)   | 437  |
| H6-05 (0430) RUN | Terminal RP Filter Time         | <b>V/f</b> <b>CL-V/f</b> <b>OLV</b> <b>CLV</b> <b>AOLV</b> <b>OLV/PM</b> <b>AOLV/PM</b> <b>CLV/PM</b> <b>EZOLV</b><br>Sets the time constant for the pulse train input primary delay filters.   | 0.10 s<br>(0.00 - 2.00 s)   | 438  |
| H6-06 (0431) RUN | Terminal MP Monitor Selection   | <b>V/f</b> <b>CL-V/f</b> <b>OLV</b> <b>CLV</b> <b>AOLV</b> <b>OLV/PM</b> <b>AOLV/PM</b> <b>CLV/PM</b> <b>EZOLV</b><br>Sets a function for pulse train monitor output terminal MP. Sets the "x-xx" part of the Ux-xx monitor.  | 102<br>(000, 031, 101, 102, 105, 116, 501, 502, 801 - 809, 821 - 825, 831 - 839, 851 - 855) | 438  |
| H6-07 (0432) RUN | Terminal MP Frequency Scaling   | <b>V/f</b> <b>CL-V/f</b> <b>OLV</b> <b>CLV</b> <b>AOLV</b> <b>OLV/PM</b> <b>AOLV/PM</b> <b>CLV/PM</b> <b>EZOLV</b><br>Sets the frequency of the pulse train output signal used when the monitor set with H6-06 [Terminal MP Monitor Selection] is 100%.   | 1440 Hz<br>(0 - 32000 Hz)   | 439  |
| H6-08 (043F)     | Terminal RP Minimum Frequency   | <b>V/f</b> <b>CL-V/f</b> <b>OLV</b> <b>CLV</b> <b>AOLV</b> <b>OLV/PM</b> <b>AOLV/PM</b> <b>CLV/PM</b> <b>EZOLV</b><br>Sets the minimum frequency of the pulse train signal that terminal RP can detect.   | 0.5 Hz<br>(0.1 - 1000.0 Hz)   | 439  |
| H6-09 (156E)     | Voltage Phase Sync MP Selection | <b>V/f</b> <b>CL-V/f</b> <b>OLV</b> <b>CLV</b> <b>AOLV</b> <b>OLV/PM</b> <b>AOLV/PM</b> <b>CLV/PM</b> <b>EZOLV</b><br>Set whether to output the pulse synchronized with drive output voltage phase from the pulse train monitor output terminal MP. This parameter is only enabled when H6-06 = 102 [Terminal MP Monitor Selection = Output Frequency] and H6-07 = 0 [Terminal MP Frequency Scaling = 0 Hz].<br>0 : No<br>1 : Yes | 0<br>(0, 1)   | 439  |

◆ H7: Virtual MFIO selection

| No. (Hex.)          | Name                            | Description   | Default (Range)         | Ref. |
|---------------------|---------------------------------|---|-------------------------|------|
| H7-00 (116F) Expert | Virtual MFIO selection          | <b>V/f</b> <b>CL-V/f</b> <b>OLV</b> <b>CLV</b> <b>AOLV</b> <b>OLV/PM</b> <b>AOLV/PM</b> <b>CLV/PM</b> <b>EZOLV</b><br>Sets the function to enable and disable the virtual I/O function. Set this parameter to 1 to operate the virtual I/O function.<br>0 : No<br>1 : Yes | 0<br>(0, 1)             | 440  |
| H7-01 (1185) Expert | Virtual Multi-Function Input 1  | <b>V/f</b> <b>CL-V/f</b> <b>OLV</b> <b>CLV</b> <b>AOLV</b> <b>OLV/PM</b> <b>AOLV/PM</b> <b>CLV/PM</b> <b>EZOLV</b><br>Sets the function that enters the virtual input set in H7-10 [Virtual Multi-Function Output 1].   | F<br>(1 - 19F)          | 440  |
| H7-02 (1186) Expert | Virtual Multi-Function Input 2  | <b>V/f</b> <b>CL-V/f</b> <b>OLV</b> <b>CLV</b> <b>AOLV</b> <b>OLV/PM</b> <b>AOLV/PM</b> <b>CLV/PM</b> <b>EZOLV</b><br>Sets the function that enters the virtual input set in H7-12 [Virtual Multi-Function Output 2].   | F<br>(1 - 19F)          | 440  |
| H7-03 (1187) Expert | Virtual Multi-Function Input 3  | <b>V/f</b> <b>CL-V/f</b> <b>OLV</b> <b>CLV</b> <b>AOLV</b> <b>OLV/PM</b> <b>AOLV/PM</b> <b>CLV/PM</b> <b>EZOLV</b><br>Sets the function that enters the virtual input set in H7-14 [Virtual Multi-Function Output 3].   | F<br>(1 - 19F)          | 440  |
| H7-04 (1188) Expert | Virtual Multi-Function Input 4  | <b>V/f</b> <b>CL-V/f</b> <b>OLV</b> <b>CLV</b> <b>AOLV</b> <b>OLV/PM</b> <b>AOLV/PM</b> <b>CLV/PM</b> <b>EZOLV</b><br>Sets the function that enters the virtual input set in H7-16 [Virtual Multi-Function Output 4].   | F<br>(1 - 19F)          | 440  |
| H7-10 (11A4) Expert | Virtual Multi-Function Output 1 | <b>V/f</b> <b>CL-V/f</b> <b>OLV</b> <b>CLV</b> <b>AOLV</b> <b>OLV/PM</b> <b>AOLV/PM</b> <b>CLV/PM</b> <b>EZOLV</b><br>Sets the function for virtual digital output 1.   | F<br>(0 - 1A7)          | 441  |
| H7-11 (11A5) Expert | Virtual Output 1 Delay Time     | <b>V/f</b> <b>CL-V/f</b> <b>OLV</b> <b>CLV</b> <b>AOLV</b> <b>OLV/PM</b> <b>AOLV/PM</b> <b>CLV/PM</b> <b>EZOLV</b><br>Sets the minimum ON time for virtual digital output 1.  | 0.1 s<br>(0.0 - 25.0 s) | 441  |
| H7-12 (11A6) Expert | Virtual Multi-Function Output 2 | <b>V/f</b> <b>CL-V/f</b> <b>OLV</b> <b>CLV</b> <b>AOLV</b> <b>OLV/PM</b> <b>AOLV/PM</b> <b>CLV/PM</b> <b>EZOLV</b><br>Sets the function for virtual digital output 2.   | F<br>(0 - 1A7)          | 441  |
| H7-13 (11A7) Expert | Virtual Output 2 Delay Time     | <b>V/f</b> <b>CL-V/f</b> <b>OLV</b> <b>CLV</b> <b>AOLV</b> <b>OLV/PM</b> <b>AOLV/PM</b> <b>CLV/PM</b> <b>EZOLV</b><br>Sets the minimum ON time for virtual digital output 2.  | 0.1 s<br>(0.0 - 25.0 s) | 441  |

## 1.10 H: Terminal Functions

| No. (Hex.)              | Name                                    | Description  | Default (Range)             | Ref. |
|-------------------------|---|--|-----------------------------|------|
| H7-14 (11A8) Expert     | Virtual Multi-Function Output 3         | <b>V/f</b> <b>CL-V/f</b> <b>OLV</b> <b>CLV</b> <b>AOLV</b> <b>OLV/PM</b> <b>AOLV/PM</b> <b>CLV/PM</b> <b>EZOLV</b><br>Sets the function for virtual digital output 3.  | F<br>(0 - 1A7)              | 441  |
| H7-15 (11A9) Expert     | Virtual Output 3 Delay Time             | <b>V/f</b> <b>CL-V/f</b> <b>OLV</b> <b>CLV</b> <b>AOLV</b> <b>OLV/PM</b> <b>AOLV/PM</b> <b>CLV/PM</b> <b>EZOLV</b><br>Sets the minimum ON time for virtual digital output 3.   | 0.1 s<br>(0.0 - 25.0 s)     | 441  |
| H7-16 (11AA) Expert     | Virtual Multi-Function Output 4         | <b>V/f</b> <b>CL-V/f</b> <b>OLV</b> <b>CLV</b> <b>AOLV</b> <b>OLV/PM</b> <b>AOLV/PM</b> <b>CLV/PM</b> <b>EZOLV</b><br>Sets the function for virtual digital output 4.  | F<br>(0 - 1A7)              | 441  |
| H7-17 (11AB) Expert     | Virtual Output 4 Delay Time             | <b>V/f</b> <b>CL-V/f</b> <b>OLV</b> <b>CLV</b> <b>AOLV</b> <b>OLV/PM</b> <b>AOLV/PM</b> <b>CLV/PM</b> <b>EZOLV</b><br>Sets the minimum ON time for virtual digital output 4.   | 0.1 s<br>(0.0 - 25.0 s)     | 442  |
| H7-30 (1177) Expert     | Sets the virtual analog input function. | <b>V/f</b> <b>CL-V/f</b> <b>OLV</b> <b>CLV</b> <b>AOLV</b> <b>OLV/PM</b> <b>AOLV/PM</b> <b>CLV/PM</b> <b>EZOLV</b><br>Sets the virtual analog input function.  | F<br>(0 - 32)               | 442  |
| H7-31 (1178) RUN Expert | Virtual Analog Input Gain               | <b>V/f</b> <b>CL-V/f</b> <b>OLV</b> <b>CLV</b> <b>AOLV</b> <b>OLV/PM</b> <b>AOLV/PM</b> <b>CLV/PM</b> <b>EZOLV</b><br>Sets the virtual analog input gain.  | 100.0%<br>(-999.9 - 999.9%) | 442  |
| H7-32 (1179) RUN Expert | Virtual Analog Input Bias               | <b>V/f</b> <b>CL-V/f</b> <b>OLV</b> <b>CLV</b> <b>AOLV</b> <b>OLV/PM</b> <b>AOLV/PM</b> <b>CLV/PM</b> <b>EZOLV</b><br>Sets the virtual analog input bias.  | 0.0%<br>(-999.9 - 999.9%)   | 442  |
| H7-40 (1163)            | Virtual Analog Out Signal Select        | <b>V/f</b> <b>CL-V/f</b> <b>OLV</b> <b>CLV</b> <b>AOLV</b> <b>OLV/PM</b> <b>AOLV/PM</b> <b>CLV/PM</b> <b>EZOLV</b><br>Sets the signal level of the virtual analog output.<br>0 : 0 to 100% (Absolute Value)<br>1 : -100 to 100%<br>2 : 0 to 100% (Lower Limit at 0)                                | 0<br>(0 - 2)                | 442  |
| H7-41 (1164)            | Virtual Analog Output Function          | <b>V/f</b> <b>CL-V/f</b> <b>OLV</b> <b>CLV</b> <b>AOLV</b> <b>OLV/PM</b> <b>AOLV/PM</b> <b>CLV/PM</b> <b>EZOLV</b><br>Sets the monitor to be output from the virtual analog output.<br>Set the x-xx part of the Ux-xx [Monitor]. For example, set H7-41 = 102 to monitor U1-02 [Output Frequency]. | 102<br>(0 - 999)            | 442  |
| H7-42 (1165)            | Virtual Analog Output FilterTime        | <b>V/f</b> <b>CL-V/f</b> <b>OLV</b> <b>CLV</b> <b>AOLV</b> <b>OLV/PM</b> <b>AOLV/PM</b> <b>CLV/PM</b> <b>EZOLV</b><br>Sets the time constant for a primary filter of the virtual analog output.  | 0.00 s<br>(0.00 - 2.00 s)   | 442  |

## 1.11 L: Protection Functions

### ◆ L1: Motor Protection

| No. (Hex.)   | Name                             | Description  | Default (Range)  | Ref. |
|--------------|----------------------------------|--|--|------|
| L1-01 (0480) | Motor Overload (oL1) Protection  | <p><b>V/f</b> <b>CL-V/f</b> <b>OLV</b> <b>CLV</b> <b>AOLV</b> <b>OLV/PM</b> <b>AOLV/PM</b> <b>CLV/PM</b> <b>EZOLV</b></p> <p>Sets the motor overload protection with electronic thermal protectors.</p> <p>0 : Disabled<br/>           1 : Variable Torque<br/>           2 : Constant Torque 10:1 Speed Range<br/>           3 : Constant Torque 100:1 SpeedRange<br/>           4 : PM Variable Torque<br/>           5 : PM Constant Torque<br/>           6 : Variable Torque (50Hz)</p> <p><b>Note:</b><br/>           When only one motor is connected to a drive, set <i>L1-01 = 1 to 6 [Enabled]</i>. External thermal relays are not necessary in these conditions.</p> | Determined by A1-02<br>(0 - 6)                             | 444  |
| L1-02 (0481) | Motor Overload Protection Time   | <p><b>V/f</b> <b>CL-V/f</b> <b>OLV</b> <b>CLV</b> <b>AOLV</b> <b>OLV/PM</b> <b>AOLV/PM</b> <b>CLV/PM</b> <b>EZOLV</b></p> <p>Sets the operation time for the electronic thermal protector of the drive to prevent damage to the motor. Usually it is not necessary to change this setting.</p>   | 1.0 min<br>(0.1 - 5.0 min)                                 | 447  |
| L1-03 (0482) | Motor Thermistor oH Alarm Select | <p><b>V/f</b> <b>CL-V/f</b> <b>OLV</b> <b>CLV</b> <b>AOLV</b> <b>OLV/PM</b> <b>AOLV/PM</b> <b>CLV/PM</b> <b>EZOLV</b></p> <p>Sets drive operation when the PTC input signal entered into the drive is at the <i>oH3 [Motor Overheat Alarm]</i> detection level.</p> <p>0 : Ramp to Stop<br/>           1 : Coast to Stop<br/>           2 : Fast Stop (Use C1-09)<br/>           3 : Alarm Only</p>  | 3<br>(0 - 3)   | 448  |
| L1-04 (0483) | Motor Thermistor oH Fault Select | <p><b>V/f</b> <b>CL-V/f</b> <b>OLV</b> <b>CLV</b> <b>AOLV</b> <b>OLV/PM</b> <b>AOLV/PM</b> <b>CLV/PM</b> <b>EZOLV</b></p> <p>Sets the drive operation when the PTC input signal to the drive is at the <i>oH4 [Motor Overheat Fault (PTC Input)]</i> detection level.</p> <p>0 : Ramp to Stop<br/>           1 : Coast to Stop<br/>           2 : Fast Stop (Use C1-09)</p>  | 1<br>(0 - 2)   | 448  |
| L1-05 (0484) | Motor Thermistor Filter Time     | <p><b>V/f</b> <b>CL-V/f</b> <b>OLV</b> <b>CLV</b> <b>AOLV</b> <b>OLV/PM</b> <b>AOLV/PM</b> <b>CLV/PM</b> <b>EZOLV</b></p> <p>Sets the primary delay time constant for the PTC input signal entered to the drive. This parameter prevents accidental motor overheat faults.</p>   | 0.20 s<br>(0.00 - 10.00 s)                                 | 448  |
| L1-08 (1103) | oL1 Current Level for Motor 1    | <p><b>V/f</b> <b>CL-V/f</b> <b>OLV</b> <b>CLV</b> <b>AOLV</b> <b>OLV/PM</b> <b>AOLV/PM</b> <b>CLV/PM</b> <b>EZOLV</b></p> <p>Sets the reference current for the motor 1 thermal overload detection. When the current level &gt; 0.0 A, you cannot set this value &lt; 10% of drive rated current.</p>  | 0.0 A<br>(0.0 A or 10% to 150% of the drive rated current) | 448  |
| L1-09 (1104) | oL1 Current Level for Motor 2    | <p><b>V/f</b> <b>CL-V/f</b> <b>OLV</b> <b>CLV</b> <b>AOLV</b> <b>OLV/PM</b> <b>AOLV/PM</b> <b>CLV/PM</b> <b>EZOLV</b></p> <p>Sets the reference current for the motor 2 thermal overload detection. When the current level &gt; 0.0 A, you cannot set this value &lt; 10% of drive rated current.</p>  | 0.0 A<br>(0.0 A or 10 to 150% of the drive rated current)  | 449  |
| L1-13 (046D) | Motor Overload Memory Selection  | <p><b>V/f</b> <b>CL-V/f</b> <b>OLV</b> <b>CLV</b> <b>AOLV</b> <b>OLV/PM</b> <b>AOLV/PM</b> <b>CLV/PM</b> <b>EZOLV</b></p> <p>Sets the function that keeps the current electronic thermal protector value when the drive stops receiving power.</p> <p>0 : Disabled<br/>           1 : Enabled</p>  | 1<br>(0, 1)  | 449  |

◆ L2: Power Loss Ride Through

| No. (Hex.)          | Name                             | Description   | Default (Range)   | Ref. |
|---------------------|----------------------------------|---|---|------|
| L2-01 (0485)        | Power Loss Ride Through Select   | <p><b>V/f</b> <b>CL-V/f</b> <b>OLV</b> <b>CLV</b> <b>AOLV</b> <b>OLV/PM</b> <b>AOLV/PM</b> <b>CLV/PM</b> <b>EZOLV</b></p> <p>Sets the drive operation after a momentary power loss.</p> <p>0 : No<br/>1 : Yes<br/>2 : Enabled while CPU Power Active<br/>3 : Kinetic Energy Backup<br/>4 : Kinetic Energy Backup: CPU Power<br/>5 : Kinetic Energy Backup: DecelStop</p>  | 0<br>(0 - 5)  | 455  |
| L2-02 (0486)        | Power Loss Ride Through Time     | <p><b>V/f</b> <b>CL-V/f</b> <b>OLV</b> <b>CLV</b> <b>AOLV</b> <b>OLV/PM</b> <b>AOLV/PM</b> <b>CLV/PM</b> <b>EZOLV</b></p> <p>Sets the maximum time that the drive will wait until trying to restart after power loss.</p>   | Determined by o2-04, C6-01<br>(0.0 - 25.5 s)  | 456  |
| L2-03 (0487)        | Minimum Baseblock Time           | <p><b>V/f</b> <b>CL-V/f</b> <b>OLV</b> <b>CLV</b> <b>AOLV</b> <b>OLV/PM</b> <b>AOLV/PM</b> <b>CLV/PM</b> <b>EZOLV</b></p> <p>Sets the minimum time to continue the drive output block (baseblock) after a previous baseblock.</p>   | Determined by o2-04, C6-01<br>(0.1 - 5.0 s)   | 456  |
| L2-04 (0488)        | Powerloss V/f Recovery Ramp Time | <p><b>V/f</b> <b>CL-V/f</b> <b>OLV</b> <b>CLV</b> <b>AOLV</b> <b>OLV/PM</b> <b>AOLV/PM</b> <b>CLV/PM</b> <b>EZOLV</b></p> <p>Sets the time for the drive output voltage to go back to correct voltage after completing speed searches.</p>  | Determined by o2-04, C6-01<br>(0.0 - 5.0 s)   | 456  |
| L2-05 (0489)        | Undervoltage Detection Lvl (Uv1) | <p><b>V/f</b> <b>CL-V/f</b> <b>OLV</b> <b>CLV</b> <b>AOLV</b> <b>OLV/PM</b> <b>AOLV/PM</b> <b>CLV/PM</b> <b>EZOLV</b></p> <p>Sets the voltage at which a <i>Uv1 [DC Bus Undervoltage]</i> fault is triggered or at which the KEB function is activated. Usually it is not necessary to change this setting.</p> <p><b>NOTICE: Damage to Equipment. When you set this parameter to a value lower than the default, you must install an AC reactor on the input side of the power supply. If you do not install an AC reactor, it will cause damage to the drive circuitry.</b></p> | Determined by o2-04 and E1-01<br>(200 V Class: 150 - 210 V, 400 V Class: 300 - 420 V) | 457  |
| L2-06 (048A) Expert | Does KEB Tuning.                 | <p><b>V/f</b> <b>CL-V/f</b> <b>OLV</b> <b>CLV</b> <b>AOLV</b> <b>OLV/PM</b> <b>AOLV/PM</b> <b>CLV/PM</b> <b>EZOLV</b></p> <p>Sets the deceleration time during KEB operation used to decrease the maximum output frequency to 0.</p> <p><b>Note:</b><br/>When L2-29 = 1, 2, or 3 [<i>Kinetic Energy Backup Method = Single Drive KEB Ride-Thru 2, System KEB Ride-Thru 1, or System KEB Ride-Thru 2</i>] and you do KEB Auto-Tuning, the drive will automatically set this value.</p>   | 0.0 s<br>(0.0 - 6000.0 s)   | 457  |
| L2-07 (048B) Expert | Kinetic Energy Backup Accel Time | <p><b>V/f</b> <b>CL-V/f</b> <b>OLV</b> <b>CLV</b> <b>AOLV</b> <b>OLV/PM</b> <b>AOLV/PM</b> <b>CLV/PM</b> <b>EZOLV</b></p> <p>Sets the acceleration time to return the frequency to the frequency reference before a power loss after canceling KEB operation.</p>   | 0.0 s<br>(0.0 - 6000.0 s)   | 457  |
| L2-08 (048C) Expert | Frequency Gain at KEB Start      | <p><b>V/f</b> <b>CL-V/f</b> <b>OLV</b> <b>CLV</b> <b>AOLV</b> <b>OLV/PM</b> <b>AOLV/PM</b> <b>CLV/PM</b> <b>EZOLV</b></p> <p>Sets the quantity of output frequency reduction used when KEB operation starts as a percentage of the motor rated slip before starting KEB operation.</p>  | 100%<br>(0 - 300%)  | 458  |
| L2-09 (048D) Expert | KEB Minimum Frequency Level      | <p><b>V/f</b> <b>CL-V/f</b> <b>OLV</b> <b>CLV</b> <b>AOLV</b> <b>OLV/PM</b> <b>AOLV/PM</b> <b>CLV/PM</b> <b>EZOLV</b></p> <p>Sets the quantity of output frequency reduction used when KEB operation starts as a percentage of <i>E2-02 [Motor Rated Slip]</i>.</p>   | 20%<br>(0 - 100%)   | 458  |
| L2-10 (048E) Expert | Minimum KEB Time                 | <p><b>V/f</b> <b>CL-V/f</b> <b>OLV</b> <b>CLV</b> <b>AOLV</b> <b>OLV/PM</b> <b>AOLV/PM</b> <b>CLV/PM</b> <b>EZOLV</b></p> <p>Sets the minimum length of time to operate the KEB after the drive detects a momentary power loss.</p>   | 50 ms<br>(0 - 25500 ms)   | 458  |
| L2-11 (0461) Expert | KEB DC Bus Voltage Setpoint      | <p><b>V/f</b> <b>CL-V/f</b> <b>OLV</b> <b>CLV</b> <b>AOLV</b> <b>OLV/PM</b> <b>AOLV/PM</b> <b>CLV/PM</b> <b>EZOLV</b></p> <p>Sets the target value that controls the DC bus voltage to a constant level in Single Drive KEB Ride-Thru 2. Sets the DC bus voltage level that completes the KEB operation for all other KEB methods.</p>  | Determined by E1-01<br>(Determined by E1-01)  | 459  |
| L2-29 (0475) Expert | Kinetic Energy Backup Method     | <p><b>V/f</b> <b>CL-V/f</b> <b>OLV</b> <b>CLV</b> <b>AOLV</b> <b>OLV/PM</b> <b>AOLV/PM</b> <b>CLV/PM</b> <b>EZOLV</b></p> <p>Sets the KEB function operation mode.</p> <p>0 : Single Drive KEB Ride-Thru 1<br/>1 : Single Drive KEB Ride-Thru 2<br/>2 : System KEB Ride-Thru 1<br/>3 : System KEB Ride-Thru 2</p>   | 0<br>(0 - 3)  | 459  |

| No. (Hex.)          | Name                           | Description  | Default (Range)   | Ref. |
|---------------------|--------------------------------|--|---|------|
| L2-30 (045E) Expert | KEB Zero Speed Operation       | <p><b>V/f</b> <b>CL-V/f</b> <b>OLV</b> <b>CLV</b> <b>AOLV</b> <b>OLV/PM</b> <b>AOLV/PM</b> <b>CLV/PM</b> <b>EZOLV</b></p> <p>Sets the operation when the output frequency decreases below the zero level (DC braking injection starting frequency) during KEB deceleration when <math>L2-01 = 3</math> to <math>5</math> [Power Loss Ride Through Select = Kinetic Energy Backup: L2-02, Kinetic Energy Backup: CPU Power, or Kinetic Energy Backup: DecelStop].</p> <p>0 : Baseblock<br/>1 : DC Injection Braking</p> | 0<br>(0, 1)   | 459  |
| L2-31 (045D) Expert | KEB Start Voltage Offset Level | <p><b>V/f</b> <b>CL-V/f</b> <b>OLV</b> <b>CLV</b> <b>AOLV</b> <b>OLV/PM</b> <b>AOLV/PM</b> <b>CLV/PM</b> <b>EZOLV</b></p> <p>Sets the KEB start voltage offset.</p>  | Determined by A1-02<br>(200 V Class: 0 - 100<br>V,400 V Class: 0 - 200 V) | 460  |

### ◆ L3: Stall Prevention

| No. (Hex.)   | Name                             | Description  | Default (Range)                             | Ref. |
|--------------|----------------------------------|--|---|------|
| L3-01 (048F) | Stall Prevention during Accel    | <p><b>V/f</b> <b>CL-V/f</b> <b>OLV</b> <b>CLV</b> <b>AOLV</b> <b>OLV/PM</b> <b>AOLV/PM</b> <b>CLV/PM</b> <b>EZOLV</b></p> <p>Sets the method of the Stall Prevention During Acceleration.</p> <p>0 : No<br/>1 : Yes<br/>2 : Intelligent (Ignore Decel Ramp)<br/>3 : Current Limit Acceleration</p>   | 1<br>(0 to 3)                               | 460  |
| L3-02 (0490) | Stall Prevent Level during Accel | <p><b>V/f</b> <b>CL-V/f</b> <b>OLV</b> <b>CLV</b> <b>AOLV</b> <b>OLV/PM</b> <b>AOLV/PM</b> <b>CLV/PM</b> <b>EZOLV</b></p> <p>Sets the output current level to activate the Stall Prevention function during acceleration as a percentage of the drive rated output current.</p> <p><b>Note:</b><br/>The upper limit of the setting range changes when the setting for <math>C6-01</math> [Normal / Heavy Duty Selection] changes.</p> <ul style="list-style-type: none"> <li>• 150% when <math>C6-01 = 0</math> [Heavy Duty Rating 1 (HD1) for Constant Torque Applications].</li> <li>• 110% when <math>C6-01 = 1</math> [Normal Duty Rating 1 (ND1) for Variable Torque Applications].</li> </ul>  | Determined by C6-01 and L8-38<br>(0 - 150%) | 462  |
| L3-03 (0491) | Stall Prevent Limit during Accel | <p><b>V/f</b> <b>CL-V/f</b> <b>OLV</b> <b>CLV</b> <b>AOLV</b> <b>OLV/PM</b> <b>AOLV/PM</b> <b>CLV/PM</b> <b>EZOLV</b></p> <p>Sets the lower limit for the stall prevention level used in the constant output range as a percentage of the drive rated output current.</p>  | 50%<br>(0 - 100%)                           | 462  |
| L3-04 (0492) | Stall Prevention during Decel    | <p><b>V/f</b> <b>CL-V/f</b> <b>OLV</b> <b>CLV</b> <b>AOLV</b> <b>OLV/PM</b> <b>AOLV/PM</b> <b>CLV/PM</b> <b>EZOLV</b></p> <p>Sets the method that the drive will use to prevent overvoltage faults when decelerating.</p> <p><b>Note:</b></p> <ol style="list-style-type: none"> <li>1. To connect a dynamic braking option (braking resistor or braking resistor unit) to the drive, set this parameter to 0 or 3. Parameter values 1, 2, 4, and 5 will enable Stall Prevention function during deceleration, and the dynamic braking option will not function.</li> <li>2. The setting range changes when the <math>A1-02</math> [Control Method Selection] value changes: <ul style="list-style-type: none"> <li>• When <math>A1-02 = 5</math> [OLV/PM], the setting range is 0 to 2.</li> <li>• When <math>A1-02 = 6, 7, 8</math> [AOLV/PM, CLV/PM, EZOLV], the setting range is 0, 1.</li> </ul> </li> </ol> <p>0 : No<br/>1 : General Purpose<br/>2 : Intelligent (Ignore Decel Ramp)<br/>3 : General Purpose w/ DB resistor<br/>4 : Overexcitation/High Flux<br/>5 : Overexcitation/High Flux 2</p> | 1<br>(Determined by A1-02)                  | 463  |
| L3-05 (0493) | Stall Prevention during RUN      | <p><b>V/f</b> <b>CL-V/f</b> <b>OLV</b> <b>CLV</b> <b>AOLV</b> <b>OLV/PM</b> <b>AOLV/PM</b> <b>CLV/PM</b> <b>EZOLV</b></p> <p>Sets the function to enable and disable Stall Prevention During Run.</p> <p><b>Note:</b></p> <ol style="list-style-type: none"> <li>1. An output frequency less than 6 Hz will disable Stall Prevention during Run regardless of <math>L3-05</math> and <math>L3-06</math> [Stall Prevent Level during Run] settings.</li> <li>2. The setting range changes when the <math>A1-02</math> [Control Method] value changes: <ul style="list-style-type: none"> <li>• <math>A1-02 = 0, 1, 5</math> [V/f, CL-V/f, OLV/PM]: 0 to 2</li> <li>• <math>A1-02 = 8</math> [EZOLV]: 0, 3</li> </ul> </li> </ol> <p>0 : No<br/>1 : Deceleration Time 1 (C1-02)<br/>2 : Deceleration Time 2 (C1-04)<br/>3 : Intelligent (Ignore Decel Ramp)</p>  | 2<br>(0 - Determined by A1-02)              | 464  |

## 1.11 L: Protection Functions

| No. (Hex.)          | Name                             | Description   | Default (Range)  | Ref. |
|---------------------|----------------------------------|---|--|------|
| L3-06 (0494)        | Stall Prevent Level during Run   | <p><b>V/f</b> <b>CL-V/f</b> <b>OLV</b> <b>CLV</b> <b>AOLV</b> <b>OLV/PM</b> <b>AOLV/PM</b> <b>CLV/PM</b> <b>EZOLV</b></p> <p>Sets the output current level to enable the Stall Prevention function during operation as a percentage of the drive rated output current.</p> <p><b>Note:</b></p> <ul style="list-style-type: none"> <li>This parameter is applicable if <math>L3-05 = 1, 2</math> [Stall Prevention during RUN = Deceleration Time 1 (C1-02), Deceleration Time 2 (C1-04)].</li> <li>The upper limit of the setting range changes when the setting for C6-01 [Normal / Heavy Duty Selection] changes. <ul style="list-style-type: none"> <li>-150% when C6-01 = 0 [Heavy Duty Rating 1 (HD1) for Constant Torque Applications].</li> <li>-110% when C6-01 = 1 [Normal Duty Rating 1 (ND1) for Variable Torque Applications].</li> </ul> </li> </ul> | Determined by C6-01 and L8-38 (5 - 150%)   | 465  |
| L3-11 (04C7)        | Overvoltage Suppression Select   | <p><b>V/f</b> <b>CL-V/f</b> <b>OLV</b> <b>CLV</b> <b>AOLV</b> <b>OLV/PM</b> <b>AOLV/PM</b> <b>CLV/PM</b> <b>EZOLV</b></p> <p>Sets the overvoltage suppression function.</p> <p>0 : No<br/>1 : Yes</p>   | 0 (0, 1)   | 466  |
| L3-17 (0462)        | DC Bus Regulation Level          | <p><b>V/f</b> <b>CL-V/f</b> <b>OLV</b> <b>CLV</b> <b>AOLV</b> <b>OLV/PM</b> <b>AOLV/PM</b> <b>CLV/PM</b> <b>EZOLV</b></p> <p>Sets the target value for the DC bus voltage when the overvoltage suppression function and the Decel Stall Prevention function (Intelligent Stall Prevention) are active.</p>  | 200 V Class: 375 V, 400 V, 750 V<br>(200 V Class: 150 to 400 V, 400 V Class: 300 to 800 V) | 466  |
| L3-20 (0465) Expert | DC Bus Voltage Adjustment Gain   | <p><b>V/f</b> <b>CL-V/f</b> <b>OLV</b> <b>CLV</b> <b>AOLV</b> <b>OLV/PM</b> <b>AOLV/PM</b> <b>CLV/PM</b> <b>EZOLV</b></p> <p>Sets the proportional gain used to control the DC bus voltage.</p>   | Determined by A1-02 (0.00 - 5.00)  | 466  |
| L3-21 (0466) Expert | OVSuppression Accel/Decel P Gain | <p><b>V/f</b> <b>CL-V/f</b> <b>OLV</b> <b>CLV</b> <b>AOLV</b> <b>OLV/PM</b> <b>AOLV/PM</b> <b>CLV/PM</b> <b>EZOLV</b></p> <p>Sets the proportional gain to calculate acceleration and deceleration rates.</p>   | Determined by A1-02 (0.10 - 10.00)   | 466  |
| L3-22 (04F9)        | PM Stall Prevention Decel Time   | <p><b>V/f</b> <b>CL-V/f</b> <b>OLV</b> <b>CLV</b> <b>AOLV</b> <b>OLV/PM</b> <b>AOLV/PM</b> <b>CLV/PM</b> <b>EZOLV</b></p> <p>Sets the momentary deceleration time that the drive will use when it tries to accelerate a PM motor and detected motor stalls. This function is applicable when <math>L3-01 = 1</math> [Stall Prevent Select during Accel = General Purpose].</p>  | 0.0 s (0.0 - 6000.0 s)   | 467  |
| L3-23 (04FD)        | Stall P Reduction at Constant HP | <p><b>V/f</b> <b>CL-V/f</b> <b>OLV</b> <b>CLV</b> <b>AOLV</b> <b>OLV/PM</b> <b>AOLV/PM</b> <b>CLV/PM</b> <b>EZOLV</b></p> <p>Sets the function to automatically decrease the Stall Prevention Level during Run for constant output ranges.</p> <p>0 : No<br/>1 : Yes</p>  | 0 (0, 1)   | 467  |
| L3-24 (046E) Expert | Motor Accel Time for Inertia Cal | <p><b>V/f</b> <b>CL-V/f</b> <b>OLV</b> <b>CLV</b> <b>AOLV</b> <b>OLV/PM</b> <b>AOLV/PM</b> <b>CLV/PM</b> <b>EZOLV</b></p> <p>Sets the motor acceleration time to reach the maximum frequency at the motor rated torque for stopped single-drive motors.</p>   | Determined by o2-04, C6-01, E2-11, and E5-01 (0.001 - 10.000 s)                            | 467  |
| L3-25 (046F) Expert | Load Inertia Ratio               | <p><b>V/f</b> <b>CL-V/f</b> <b>OLV</b> <b>CLV</b> <b>AOLV</b> <b>OLV/PM</b> <b>AOLV/PM</b> <b>CLV/PM</b> <b>EZOLV</b></p> <p>Sets the ratio between motor inertia and machine inertia.</p>  | 1.0 (0.1 - 1000.0)   | 468  |
| L3-26 (0455) Expert | Additional DC Bus Capacitors     | <p><b>V/f</b> <b>CL-V/f</b> <b>OLV</b> <b>CLV</b> <b>AOLV</b> <b>OLV/PM</b> <b>AOLV/PM</b> <b>CLV/PM</b> <b>EZOLV</b></p> <p>Sets the capacity for external main circuit capacitors. Usually it is not necessary to change this setting. Sets this parameter when you use the KEB Ride-Thru function.</p>   | 0 μF (0 to 65000 μF)   | 468  |
| L3-27 (0456)        | Stall Prevention Detection Time  | <p><b>V/f</b> <b>CL-V/f</b> <b>OLV</b> <b>CLV</b> <b>AOLV</b> <b>OLV/PM</b> <b>AOLV/PM</b> <b>CLV/PM</b> <b>EZOLV</b></p> <p>Sets a delay time between reaching the Stall Prevention level and starting the Stall Prevention function.</p>  | 50 ms (0 - 5000 ms)  | 468  |
| L3-34 (016F) Expert | Torque Limit Delay Time          | <p><b>V/f</b> <b>CL-V/f</b> <b>OLV</b> <b>CLV</b> <b>AOLV</b> <b>OLV/PM</b> <b>AOLV/PM</b> <b>CLV/PM</b> <b>EZOLV</b></p> <p>Sets the filter time constant that returns the torque limit to its initial value when KEB operation operates in Single Drive KEB Ride-Thru mode.</p>   | Determined by A1-02 (0.000 - 1.000 s)  | 468  |
| L3-35 (0747) Expert | Speed Agree Width for Auto Decel | <p><b>V/f</b> <b>CL-V/f</b> <b>OLV</b> <b>CLV</b> <b>AOLV</b> <b>OLV/PM</b> <b>AOLV/PM</b> <b>CLV/PM</b> <b>EZOLV</b></p> <p>Sets the width for speed agreement when <math>L3-04 = 2</math> [Decel Stall Prevention Selection = Automatic Decel Reduction]. Usually it is not necessary to change this setting.</p>   | 0.00 Hz (0.00 - 1.00 Hz)   | 469  |
| L3-36 (11D0)        | Current Suppression Gain@Accel   | <p><b>V/f</b> <b>CL-V/f</b> <b>OLV</b> <b>CLV</b> <b>AOLV</b> <b>OLV/PM</b> <b>AOLV/PM</b> <b>CLV/PM</b> <b>EZOLV</b></p> <p>Sets the gain to suppress current and motor speed hunting during operation when <math>L3-01 = 3</math> [Stall Prevention during Accel = Current Limit Method]. Usually it is not necessary to change this setting.</p>   | Determined by A1-02 (0.0 - 100.0)  | 469  |
| L3-37 (11D1) Expert | Current Limit P Gain @ Accel     | <p><b>V/f</b> <b>CL-V/f</b> <b>OLV</b> <b>CLV</b> <b>AOLV</b> <b>OLV/PM</b> <b>AOLV/PM</b> <b>CLV/PM</b> <b>EZOLV</b></p> <p>Suppresses current hunting that occurs during acceleration. Usually it is not necessary to change this setting.</p>  | 5 ms (0 - 100 ms)  | 469  |
| L3-38 (11D2) Expert | Current Limit I Time @ Accel     | <p><b>V/f</b> <b>CL-V/f</b> <b>OLV</b> <b>CLV</b> <b>AOLV</b> <b>OLV/PM</b> <b>AOLV/PM</b> <b>CLV/PM</b> <b>EZOLV</b></p> <p>Suppresses current hunting and overshooting that occurs when the drive stalls during acceleration. Usually it is not necessary to change this setting.</p>   | 10.0 (0.0 - 100.0)   | 469  |



| No. (Hex.)   | Name                             | Description   | Default (Range)               | Ref. |
|--------------|----------------------------------|---|-------------------------------|------|
| L3-39 (11D3) | Current Limit Filter Time @Accel | <b>V/f</b> <b>CL-V/f</b> <b>OLV</b> <b>CLV</b> <b>AOLV</b> <b>OLV/PM</b> <b>AOLV/PM</b> <b>CLV/PM</b> <b>EZOLV</b><br>Sets the time constant to adjust the acceleration rate when L3-01 = 3 [Stall Prevention during Accel = Current Limit Method]. Usually it is not necessary to change this setting. | 100.0 ms<br>(1.0 - 1000.0 ms) | 469  |
| L3-40 (11D4) | Current Limit S-Curve @ Acc/Dec  | <b>V/f</b> <b>CL-V/f</b> <b>OLV</b> <b>CLV</b> <b>AOLV</b> <b>OLV/PM</b> <b>AOLV/PM</b> <b>CLV/PM</b> <b>EZOLV</b><br>Sets the function to enable and disable the best S-curve characteristic used for current-limited acceleration.<br>0 : No<br>1 : Yes   | 0<br>(0, 1)                   | 470  |

#### ◆ L4: Speed Detection

| No. (Hex.)   | Name                              | Description   | Default (Range)                              | Ref. |
|--------------|-----------------------------------|---|--|------|
| L4-01 (0499) | Speed Agree Detection Level       | <b>V/f</b> <b>CL-V/f</b> <b>OLV</b> <b>CLV</b> <b>AOLV</b> <b>OLV/PM</b> <b>AOLV/PM</b> <b>CLV/PM</b> <b>EZOLV</b><br>Sets the level to detect speed agree or motor speed.<br>Sets the level to detect speed agree or motor speed when H2-01 to H2-03 = 2, 3, 4, 5 [MFDO Function Selection = Speed Agree 1, User-set Speed Agree 1, Frequency Detection 1, Frequency Detection 2].                     | Determined by A1-02<br>(Determined by A1-02) | 470  |
| L4-02 (049A) | Speed Agree Detection Width       | <b>V/f</b> <b>CL-V/f</b> <b>OLV</b> <b>CLV</b> <b>AOLV</b> <b>OLV/PM</b> <b>AOLV/PM</b> <b>CLV/PM</b> <b>EZOLV</b><br>Sets the width to detect speed agree or motor speed.<br>Sets the width to detect speed agree or motor speed when H2-01 to H2-03 = 2, 3, 4, 5 [MFDO Function Selection = Speed Agree 1, User-set Speed Agree 1, Frequency Detection 1, Frequency Detection 2].                     | Determined by A1-02<br>(Determined by A1-02) | 470  |
| L4-03 (049B) | Speed Agree Detection Level (+/-) | <b>V/f</b> <b>CL-V/f</b> <b>OLV</b> <b>CLV</b> <b>AOLV</b> <b>OLV/PM</b> <b>AOLV/PM</b> <b>CLV/PM</b> <b>EZOLV</b><br>Sets the level to detect speed agree or motor speed.<br>Sets the speed agree detection level or motor speed detection level when H2-01 to H2-03 = 13, 14, 15, 16 [MFDO Function Selection = Speed Agree 2, User-set Speed Agree 2, Frequency Detection 3, Frequency Detection 4]. | Determined by A1-02<br>(Determined by A1-02) | 470  |
| L4-04 (049C) | Speed Agree Detection Width (+/-) | <b>V/f</b> <b>CL-V/f</b> <b>OLV</b> <b>CLV</b> <b>AOLV</b> <b>OLV/PM</b> <b>AOLV/PM</b> <b>CLV/PM</b> <b>EZOLV</b><br>Sets the width to detect speed agree or motor speed.<br>Sets the width to detect speed agree or motor speed when H2-01 to H2-03 = 13, 14, 15, 16 [MFDO Function Selection = Speed Agree 2, User-set Speed Agree 2, Frequency Detection 3, Frequency Detection 4].                 | Determined by A1-02<br>(Determined by A1-02) | 470  |
| L4-05 (049D) | Fref Loss Detection Selection     | <b>V/f</b> <b>CL-V/f</b> <b>OLV</b> <b>CLV</b> <b>AOLV</b> <b>OLV/PM</b> <b>AOLV/PM</b> <b>CLV/PM</b> <b>EZOLV</b><br>Sets the operation when the drive detects a loss of frequency reference.<br>0 : Stop<br>1 : Run at (L4-06 x Last Reference)   | 0<br>(0, 1)                                  | 471  |
| L4-06 (04C2) | Frequency Reference @Loss of Ref  | <b>V/f</b> <b>CL-V/f</b> <b>OLV</b> <b>CLV</b> <b>AOLV</b> <b>OLV/PM</b> <b>AOLV/PM</b> <b>CLV/PM</b> <b>EZOLV</b><br>Sets the frequency reference as a percentage to continue drive operation after it detects a frequency reference loss. The value is a percentage of the frequency reference before the drive detected the loss.  | 80.0%<br>(0.0 - 100.0%)                      | 471  |
| L4-07 (0470) | Speed Agree Detection Selection   | <b>V/f</b> <b>CL-V/f</b> <b>OLV</b> <b>CLV</b> <b>AOLV</b> <b>OLV/PM</b> <b>AOLV/PM</b> <b>CLV/PM</b> <b>EZOLV</b><br>Sets the condition that activates speed detection.<br>0 : No Detection during Baseblock<br>1 : Detection Always Enabled   | 0<br>(0, 1)                                  | 471  |

#### ◆ L5: Fault Restart

| No. (Hex.)   | Name                            | Description   | Default (Range)           | Ref. |
|--------------|---------------------------------|---|---------------------------|------|
| L5-01 (049E) | Number of Auto-Restart Attempts | <b>V/f</b> <b>CL-V/f</b> <b>OLV</b> <b>CLV</b> <b>AOLV</b> <b>OLV/PM</b> <b>AOLV/PM</b> <b>CLV/PM</b> <b>EZOLV</b><br>Sets the number of times that the drive will try to restart.  | 0<br>(0 - 10 times)       | 472  |
| L5-02 (049F) | Fault Contact at Restart Select | <b>V/f</b> <b>CL-V/f</b> <b>OLV</b> <b>CLV</b> <b>AOLV</b> <b>OLV/PM</b> <b>AOLV/PM</b> <b>CLV/PM</b> <b>EZOLV</b><br>Sets the function that sends signals to the MFDO terminal set for Fault [H2-xx = E] while the drive is automatically restarting.<br>0 : Active Only when Not Restarting<br>1 : Always Active                                  | 0<br>(0, 1)               | 472  |
| L5-03 (04A0) | Auto-Restart Duration           | <b>V/f</b> <b>CL-V/f</b> <b>OLV</b> <b>CLV</b> <b>AOLV</b> <b>OLV/PM</b> <b>AOLV/PM</b> <b>CLV/PM</b> <b>EZOLV</b><br>Sets the time for which the drive will try to restart. If the drive cannot restart within the time set in L5-03, a fault is detected. This is available when L5-05 = 0 [Auto-Restart Method = Continuous/Immediate Attempts]. | 10.0 s<br>(0.5 - 180.0 s) | 472  |



## ◆ L6: Torque Detection

| No. (Hex.)   | Name                             | Description  | Default (Range)             | Ref. |
|--------------|----------------------------------|--|-----------------------------|------|
| L6-01 (04A1) | Torque Detection Selection 1     | <p><b>V/f</b> <b>CL-V/f</b> <b>OLV</b> <b>CLV</b> <b>AOLV</b> <b>OLV/PM</b> <b>AOLV/PM</b> <b>CLV/PM</b> <b>EZOLV</b></p> <p>Sets the speed range that detects overtorque and undertorque and the operation of drives (operation status) after detection.</p> <p>0: Disabled<br/>           1: oL @ Speed Agree - Alarm only<br/>           2: oL @ RUN - Alarm only<br/>           3: oL @ Speed Agree - Fault<br/>           4: oL @ RUN - Fault<br/>           5: UL @ Speed Agree - Alarm only<br/>           6: UL @ RUN - Alarm only<br/>           7: UL @ Speed Agree - Fault<br/>           8: UL @ RUN - Fault</p>   | 0<br>(0 - 8)                | 476  |
| L6-02 (04A2) | Torque Detection Level 1         | <p><b>V/f</b> <b>CL-V/f</b> <b>OLV</b> <b>CLV</b> <b>AOLV</b> <b>OLV/PM</b> <b>AOLV/PM</b> <b>CLV/PM</b> <b>EZOLV</b></p> <p>Sets the detection level for Overtorque/Undertorque Detection 1. In V/f control, drive rated output current = 100% value. In vector control, motor rated torque = 100% value.</p>   | 150%<br>(0 - 300%)          | 477  |
| L6-03 (04A3) | Torque Detection Time 1          | <p><b>V/f</b> <b>CL-V/f</b> <b>OLV</b> <b>CLV</b> <b>AOLV</b> <b>OLV/PM</b> <b>AOLV/PM</b> <b>CLV/PM</b> <b>EZOLV</b></p> <p>Sets the detection time for Overtorque/Undertorque Detection 1.</p>   | 0.1 s<br>(0.0 - 10.0 s)     | 477  |
| L6-04 (04A4) | Torque Detection Selection 2     | <p><b>V/f</b> <b>CL-V/f</b> <b>OLV</b> <b>CLV</b> <b>AOLV</b> <b>OLV/PM</b> <b>AOLV/PM</b> <b>CLV/PM</b> <b>EZOLV</b></p> <p>Sets the speed range that detects overtorque and undertorque and the operation of drives (operation status) after detection.</p> <p>0: Disabled<br/>           1: oL @ Speed Agree - Alarm only<br/>           2: oL @ RUN - Alarm only<br/>           3: oL @ Speed Agree - Fault<br/>           4: oL @ RUN - Fault<br/>           5: UL @ Speed Agree - Alarm only<br/>           6: UL @ RUN - Alarm only<br/>           7: UL @ Speed Agree - Fault<br/>           8: UL @ RUN - Fault</p>   | 0<br>(0 - 8)                | 477  |
| L6-05 (04A5) | Torque Detection Level 2         | <p><b>V/f</b> <b>CL-V/f</b> <b>OLV</b> <b>CLV</b> <b>AOLV</b> <b>OLV/PM</b> <b>AOLV/PM</b> <b>CLV/PM</b> <b>EZOLV</b></p> <p>Sets the detection level for Overtorque/Undertorque Detection 2. In V/f control, drive rated output current = 100% value. In vector control, motor rated torque = 100% value.</p>   | 150%<br>(0 - 300%)          | 478  |
| L6-06 (04A6) | Torque Detection Time 2          | <p><b>V/f</b> <b>CL-V/f</b> <b>OLV</b> <b>CLV</b> <b>AOLV</b> <b>OLV/PM</b> <b>AOLV/PM</b> <b>CLV/PM</b> <b>EZOLV</b></p> <p>Sets the detection time for Overtorque/Undertorque Detection 2.</p>   | 0.1 s<br>(0.0 - 10.0 s)     | 478  |
| L6-07 (04E5) | Torque Detection Filter Time     | <p><b>V/f</b> <b>CL-V/f</b> <b>OLV</b> <b>CLV</b> <b>AOLV</b> <b>OLV/PM</b> <b>AOLV/PM</b> <b>CLV/PM</b> <b>EZOLV</b></p> <p>Sets the time constant for a primary filter to the torque reference or to the output current used to detect overtorque/undertorque.</p>   | 0 ms<br>(0 - 1000 ms)       | 478  |
| L6-08 (0468) | Mechanical Fatigue Detect Select | <p><b>V/f</b> <b>CL-V/f</b> <b>OLV</b> <b>CLV</b> <b>AOLV</b> <b>OLV/PM</b> <b>AOLV/PM</b> <b>CLV/PM</b> <b>EZOLV</b></p> <p>Sets the speed where the drive detects mechanical deterioration and how the drive operates (operation status) after detection.</p> <p>0: Disabled<br/>           1: oL5 @ Speed &gt; L6-09 - Alarm<br/>           2: oL5 @  Speed  &gt; L6-09 - Alarm<br/>           3: oL5 @ Speed &gt; L6-09 - Fault<br/>           4: oL5 @  Speed  &gt; L6-09 - Fault<br/>           5: UL5 @ Speed &lt; L6-09 - Alarm<br/>           6: UL5 @  Speed  &lt; L6-09 - Alarm<br/>           7: UL5 @ Speed &lt; L6-09 - Fault<br/>           8: UL5 @  Speed  &lt; L6-09 - Fault</p> | 0<br>(0 - 8)                | 478  |
| L6-09 (0469) | Mech Fatigue Detect Speed Level  | <p><b>V/f</b> <b>CL-V/f</b> <b>OLV</b> <b>CLV</b> <b>AOLV</b> <b>OLV/PM</b> <b>AOLV/PM</b> <b>CLV/PM</b> <b>EZOLV</b></p> <p>Sets the speed level where the drive will operate the mechanical deterioration detection function, as a percentage of the Maximum Output Frequency.</p> <p><b>Note:</b><br/>           Parameter A1-02 [Control Method Selection] selects which parameter is the maximum output frequency.<br/>           • A1-02 ≠ 8 [EZOLV]: E1-04 [Maximum Output Frequency]<br/>           • A1-02 = 8: E9-02 [Maximum Speed]</p>   | 110.0%<br>(-110.0 - 110.0%) | 479  |

## 1.11 L: Protection Functions

| No. (Hex.)   | Name                           | Description  | Default (Range)         | Ref. |
|--------------|--------------------------------|--|-------------------------|------|
| L6-10 (046A) | Mech Fatigue Detect Delay Time | <input type="checkbox"/> Vf <input type="checkbox"/> CL-V/f <input type="checkbox"/> OLV <input type="checkbox"/> CLV <input type="checkbox"/> AOLV <input type="checkbox"/> OLV/PM <input type="checkbox"/> AOLV/PM <input type="checkbox"/> CLV/PM <input type="checkbox"/> EZOLV<br>Sets the time for mechanical deterioration detection.   | 0.1 s<br>(0.0 - 10.0 s) | 479  |
| L6-11 (046B) | Mech Fatigue Hold Off Time     | <input type="checkbox"/> Vf <input type="checkbox"/> CL-V/f <input type="checkbox"/> OLV <input type="checkbox"/> CLV <input type="checkbox"/> AOLV <input type="checkbox"/> OLV/PM <input type="checkbox"/> AOLV/PM <input type="checkbox"/> CLV/PM <input type="checkbox"/> EZOLV<br>Sets the time that the drive will start mechanical deterioration detection triggered by the cumulative operation time of the drive. | 0 h<br>(0 - 65535 h)    | 479  |

### ◆ L7: Torque Limit

| No. (Hex.)          | Name                            | Description   | Default (Range)           | Ref. |
|---------------------|---------------------------------|---|---------------------------|------|
| L7-01 (04A7) RUN    | Forward Torque Limit            | <input type="checkbox"/> Vf <input type="checkbox"/> CL-V/f <input type="checkbox"/> OLV <input type="checkbox"/> CLV <input type="checkbox"/> AOLV <input type="checkbox"/> OLV/PM <input type="checkbox"/> AOLV/PM <input type="checkbox"/> CLV/PM <input type="checkbox"/> EZOLV<br>Sets the torque limit value for forward motoring as a percentage, where motor rated torque is the 100% value.                        | 200%<br>(0 - 300%)        | 480  |
| L7-02 (04A8) RUN    | Reverse Torque Limit            | <input type="checkbox"/> Vf <input type="checkbox"/> CL-V/f <input type="checkbox"/> OLV <input type="checkbox"/> CLV <input type="checkbox"/> AOLV <input type="checkbox"/> OLV/PM <input type="checkbox"/> AOLV/PM <input type="checkbox"/> CLV/PM <input type="checkbox"/> EZOLV<br>Sets the torque limit value for reversed motoring as a percentage, where motor rated torque is the 100% value.                       | 200%<br>(0 - 300%)        | 481  |
| L7-03 (04A9) RUN    | Forward Regenerative Trq Limit  | <input type="checkbox"/> Vf <input type="checkbox"/> CL-V/f <input type="checkbox"/> OLV <input type="checkbox"/> CLV <input type="checkbox"/> AOLV <input type="checkbox"/> OLV/PM <input type="checkbox"/> AOLV/PM <input type="checkbox"/> CLV/PM <input type="checkbox"/> EZOLV<br>Sets the torque limit value for forward regenerative conditions as a percentage of the motor rated torque.                           | 200%<br>(0 - 300%)        | 481  |
| L7-04 (04AA) RUN    | Reverse Regenerative Trq Limit  | <input type="checkbox"/> Vf <input type="checkbox"/> CL-V/f <input type="checkbox"/> OLV <input type="checkbox"/> CLV <input type="checkbox"/> AOLV <input type="checkbox"/> OLV/PM <input type="checkbox"/> AOLV/PM <input type="checkbox"/> CLV/PM <input type="checkbox"/> EZOLV<br>Sets the torque limit value for reversed regenerative conditions as a percentage of the motor rated torque.                          | 200%<br>(0 - 300%)        | 481  |
| L7-06 (04AC)        | Torque Limit Integral Time      | <input type="checkbox"/> Vf <input type="checkbox"/> CL-V/f <input type="checkbox"/> OLV <input type="checkbox"/> CLV <input type="checkbox"/> AOLV <input type="checkbox"/> OLV/PM <input type="checkbox"/> AOLV/PM <input type="checkbox"/> CLV/PM <input type="checkbox"/> EZOLV<br>Sets the integral time constant for the torque limit function.   | 200 ms<br>(5 - 10000 ms)  | 481  |
| L7-07 (04C9)        | Torque Limit during Accel/Decel | <input type="checkbox"/> Vf <input type="checkbox"/> CL-V/f <input type="checkbox"/> OLV <input type="checkbox"/> CLV <input type="checkbox"/> AOLV <input type="checkbox"/> OLV/PM <input type="checkbox"/> AOLV/PM <input type="checkbox"/> CLV/PM <input type="checkbox"/> EZOLV<br>Sets the torque limit function during acceleration and deceleration.<br>0 : Proportional only<br>1 : Proportional & Integral control | 0<br>(0, 1)               | 482  |
| L7-16 (044D)        | Torque Limit Process at Start   | <input type="checkbox"/> Vf <input type="checkbox"/> CL-V/f <input type="checkbox"/> OLV <input type="checkbox"/> CLV <input type="checkbox"/> AOLV <input type="checkbox"/> OLV/PM <input type="checkbox"/> AOLV/PM <input type="checkbox"/> CLV/PM <input type="checkbox"/> EZOLV<br>Assigns a time filter to allow the torque limit to build at start.<br>0 : Disabled<br>1 : Enabled                                    | 1<br>(0, 1)               | 482  |
| L7-35 (1B57) Expert | Low Freq Regen Torque Limit Lvl | <input type="checkbox"/> Vf <input type="checkbox"/> CL-V/f <input type="checkbox"/> OLV <input type="checkbox"/> CLV <input type="checkbox"/> AOLV <input type="checkbox"/> OLV/PM <input type="checkbox"/> AOLV/PM <input type="checkbox"/> CLV/PM <input type="checkbox"/> EZOLV<br>Sets the torque limit used during low-speed regeneration. Usually it is not necessary to change this setting.                        | 50.0%<br>(0.0 - 200.0%)   | 482  |
| L7-36 (1B58) Expert | Regen Torque Limit Derate Freq  | <input type="checkbox"/> Vf <input type="checkbox"/> CL-V/f <input type="checkbox"/> OLV <input type="checkbox"/> CLV <input type="checkbox"/> AOLV <input type="checkbox"/> OLV/PM <input type="checkbox"/> AOLV/PM <input type="checkbox"/> CLV/PM <input type="checkbox"/> EZOLV<br>Sets the frequency width at which L7-35 [Low Freq Regen Torque Limit Lvl] operates.  | 6.0 Hz<br>(0.0 - 30.0 Hz) | 483  |

### ◆ L8: Drive Protection

| No. (Hex.)   | Name                          | Description   | Default (Range)                             | Ref. |
|--------------|-------------------------------|---|---|------|
| L8-01 (04AD) | 3% ERF DB Resistor Protection | <input type="checkbox"/> Vf <input type="checkbox"/> CL-V/f <input type="checkbox"/> OLV <input type="checkbox"/> CLV <input type="checkbox"/> AOLV <input type="checkbox"/> OLV/PM <input type="checkbox"/> AOLV/PM <input type="checkbox"/> CLV/PM <input type="checkbox"/> EZOLV<br>Sets the function to enable braking resistor protection with a Yaskawa ERF series braking resistor (3% ED) installed on the heatsink.<br>0 : No<br>1 : Yes                     | 0<br>(0, 1)                                 | 483  |
| L8-02 (04AE) | Overheat Alarm Level          | <input type="checkbox"/> Vf <input type="checkbox"/> CL-V/f <input type="checkbox"/> OLV <input type="checkbox"/> CLV <input type="checkbox"/> AOLV <input type="checkbox"/> OLV/PM <input type="checkbox"/> AOLV/PM <input type="checkbox"/> CLV/PM <input type="checkbox"/> EZOLV<br>Sets the oH detection level in temperature.  | Determined by o2-04, C6-01<br>(50 - 150 °C) | 483  |
| L8-03 (04AF) | Overheat Pre-Alarm Selection  | <input type="checkbox"/> Vf <input type="checkbox"/> CL-V/f <input type="checkbox"/> OLV <input type="checkbox"/> CLV <input type="checkbox"/> AOLV <input type="checkbox"/> OLV/PM <input type="checkbox"/> AOLV/PM <input type="checkbox"/> CLV/PM <input type="checkbox"/> EZOLV<br>Sets the operation of drives when an oH alarm is detected.<br>0 : Ramp to Stop<br>1 : Coast to Stop<br>2 : Fast Stop<br>3 : Alarm Only<br>4 : Operate at Reduced Speed (L8-19) | 3<br>(0 - 4)                                | 483  |

## 1.11 L: Protection Functions

| No. (Hex.)          | Name                             | Description   | Default (Range)               | Ref. |
|---------------------|----------------------------------|---|-------------------------------|------|
| L8-05 (04B1)        | Input Phase Loss Protection Sel  | <p><b>V/f</b> <b>CL-V/f</b> <b>OLV</b> <b>CLV</b> <b>AOLV</b> <b>OLV/PM</b> <b>AOLV/PM</b> <b>CLV/PM</b> <b>EZOLV</b></p> <p>Sets the function to enable and disable input phase loss detection.</p> <p>0 : No<br/>1 : Yes</p>  | 1<br>(0, 1)                   | 484  |
| L8-07 (04B3)        | Output Phase Loss Protection Sel | <p><b>V/f</b> <b>CL-V/f</b> <b>OLV</b> <b>CLV</b> <b>AOLV</b> <b>OLV/PM</b> <b>AOLV/PM</b> <b>CLV/PM</b> <b>EZOLV</b></p> <p>Sets the function to enable and disable output phase loss detection. The drive starts output phase loss detection when the output current decreases to less than 5% of the drive rated current.</p> <p><b>Note:</b><br/>The drive can incorrectly start output phase loss detection in these conditions:<br/>• The motor rated current is very small compared to the drive rating.<br/>• The drive is operating a PM motor with a small load.</p> <p>0 : No<br/>1 : Fault when one phase is lost<br/>2 : Fault when two phases are lost</p>                    | 1<br>(0 - 2)                  | 485  |
| L8-09 (04B5)        | Output Ground Fault Detection    | <p><b>V/f</b> <b>CL-V/f</b> <b>OLV</b> <b>CLV</b> <b>AOLV</b> <b>OLV/PM</b> <b>AOLV/PM</b> <b>CLV/PM</b> <b>EZOLV</b></p> <p>Sets the function to enable and disable ground fault protection.</p> <p>0 : No<br/>1 : Yes</p>   | Determined by o2-04<br>(0, 1) | 485  |
| L8-10 (04B6)        | Heatsink Fan Operation Selection | <p><b>V/f</b> <b>CL-V/f</b> <b>OLV</b> <b>CLV</b> <b>AOLV</b> <b>OLV/PM</b> <b>AOLV/PM</b> <b>CLV/PM</b> <b>EZOLV</b></p> <p>Sets operation of the heatsink cooling fan.</p> <p>0 : During Run, w/ L8-11 Off-Delay<br/>1 : Always On<br/>2 : On when Drive Temp Reaches L8-64</p>   | 0<br>(0 - 2)                  | 485  |
| L8-11 (04B7)        | Heatsink Fan Off-Delay Time      | <p><b>V/f</b> <b>CL-V/f</b> <b>OLV</b> <b>CLV</b> <b>AOLV</b> <b>OLV/PM</b> <b>AOLV/PM</b> <b>CLV/PM</b> <b>EZOLV</b></p> <p>Sets the length of time that the drive will wait before stopping the cooling fan after canceling the Run command when <math>L8-10 = 0</math> [Heatsink Cooling Fan Ope Select = Dur Run (OffDly)].</p>   | 60 s<br>(0 - 300 s)           | 486  |
| L8-12 (04B8)        | Ambient Temperature Setting      | <p><b>V/f</b> <b>CL-V/f</b> <b>OLV</b> <b>CLV</b> <b>AOLV</b> <b>OLV/PM</b> <b>AOLV/PM</b> <b>CLV/PM</b> <b>EZOLV</b></p> <p>Sets the ambient temperature of the drive installation area.</p>   | 40 °C<br>(-10 - +50 °C)       | 486  |
| L8-15 (04BB)        | Drive oL2 @ Low Speed Protection | <p><b>V/f</b> <b>CL-V/f</b> <b>OLV</b> <b>CLV</b> <b>AOLV</b> <b>OLV/PM</b> <b>AOLV/PM</b> <b>CLV/PM</b> <b>EZOLV</b></p> <p>Sets the function to decrease drive overload at low speeds to prevent damage to the main circuit transistor during low speed operation (at 6 Hz or slower) to prevent oL2 [Drive Overloaded].</p> <p><b>Note:</b><br/>Contact Yaskawa or your nearest sales representative before disabling this function at low speeds. If you frequently operate drives with high output current in low speed ranges, it can cause heat stress and decrease the life span of drive IGBTs.</p> <p>0 : Disabled (No Additional Derate)<br/>1 : Enabled (Reduced oL2 Level)</p> | 1<br>(0, 1)                   | 486  |
| L8-18 (04BE)        | Software Current Limit Selection | <p><b>V/f</b> <b>CL-V/f</b> <b>OLV</b> <b>CLV</b> <b>AOLV</b> <b>OLV/PM</b> <b>AOLV/PM</b> <b>CLV/PM</b> <b>EZOLV</b></p> <p>Set the software current limit selection function to prevent damage to the main circuit transistor caused by too much current.</p> <p>0 : Disabled<br/>1 : Enabled</p>   | 0<br>(0, 1)                   | 486  |
| L8-19 (04BF)        | Freq Reduction @ oH Pre-Alarm    | <p><b>V/f</b> <b>CL-V/f</b> <b>OLV</b> <b>CLV</b> <b>AOLV</b> <b>OLV/PM</b> <b>AOLV/PM</b> <b>CLV/PM</b> <b>EZOLV</b></p> <p>Sets the ratio at which the drive derates the frequency reference during an oH alarm.</p>  | 0.8<br>(0.1 - 0.9)            | 486  |
| L8-20 (04C0) Expert | Control Fault & Step Out Detect  | <p><b>V/f</b> <b>CL-V/f</b> <b>OLV</b> <b>CLV</b> <b>AOLV</b> <b>OLV/PM</b> <b>AOLV/PM</b> <b>CLV/PM</b> <b>EZOLV</b></p> <p>Sets operation after the drive detects a CF fault when <math>A1-02 = 4</math> [Control Method Selection = Advanced Open Loop Vector].</p> <p>0 : Disabled<br/>1 : CF/STPo Detection Enabled<br/>2 : CF ALM/Stop</p>  | 1<br>(0 - 2)                  | 487  |
| L8-27 (04DD)        | Overcurrent Detection Gain       | <p><b>V/f</b> <b>CL-V/f</b> <b>OLV</b> <b>CLV</b> <b>AOLV</b> <b>OLV/PM</b> <b>AOLV/PM</b> <b>CLV/PM</b> <b>EZOLV</b></p> <p>Sets the PM motor overcurrent detection level as a percentage of the motor rated current value.</p> <p><b>Note:</b><br/>Parameter <math>A1-02</math> [Control Method Selection] selects which parameter is the motor rated current.<br/>• <math>A1-02 \neq 8</math> [EZOLV]: <math>E5-03</math> [Motor Rated Current (FLA)]<br/>• <math>A1-02 = 8</math>: <math>E9-06</math> [Motor Rated Current (FLA)]</p>   | 300.0%<br>(0.0 - 1000.0%)     | 487  |
| L8-29 (04DF)        | Output Unbalance Detection Sel   | <p><b>V/f</b> <b>CL-V/f</b> <b>OLV</b> <b>CLV</b> <b>AOLV</b> <b>OLV/PM</b> <b>AOLV/PM</b> <b>CLV/PM</b> <b>EZOLV</b></p> <p>Sets the function to detect LF2.</p> <p>0 : No<br/>1 : Yes</p>   | 1<br>(0, 1)                   | 487  |

## 1.11 L: Protection Functions

| No. (Hex.)          | Name                             | Description   | Default (Range)                                 | Ref. |
|---------------------|----------------------------------|---|---|------|
| L8-31 (04E1)        | LF2 Detection Time               | <input type="checkbox"/> V/f <input type="checkbox"/> CL-V/f <input type="checkbox"/> OLV <input type="checkbox"/> CLV <input type="checkbox"/> AOLV <input checked="" type="checkbox"/> OLV/PM <input type="checkbox"/> AOLV/PM <input type="checkbox"/> CLV/PM <input type="checkbox"/> EZOLV<br>Sets the LF2 [Output Current Imbalance] detection time.  | 3<br>(1 to 100)                                 | 488  |
| L8-35 (04EC)        | Installation Method Selection    | <input type="checkbox"/> V/f <input type="checkbox"/> CL-V/f <input type="checkbox"/> OLV <input type="checkbox"/> CLV <input type="checkbox"/> AOLV <input checked="" type="checkbox"/> OLV/PM <input type="checkbox"/> AOLV/PM <input type="checkbox"/> CLV/PM <input type="checkbox"/> EZOLV<br>Sets the type of drive installation.<br>0 : IP20/OpenChassis Enc/Ex Heatsink<br>1 : Side-by-Side Mounting<br>2 : IP21/NEMA Type 1/IP55<br>3 : Finless  | Determined by the drive<br>(0 - 3)              | 488  |
| L8-38 (04EF)        | Carrier Frequency Reduction      | <input type="checkbox"/> V/f <input type="checkbox"/> CL-V/f <input type="checkbox"/> OLV <input type="checkbox"/> CLV <input type="checkbox"/> AOLV <input checked="" type="checkbox"/> OLV/PM <input type="checkbox"/> AOLV/PM <input type="checkbox"/> CLV/PM <input type="checkbox"/> EZOLV<br>Sets the carrier frequency reduction function. The drive reduces the carrier frequency when the output current is more than a specified level.<br>0 : Disabled<br>1 : Enabled below 6 Hz<br>2 : Enabled for All Speeds   | Determined by A1-02, C6-01 and o2-04<br>(0 - 2) | 488  |
| L8-40 (04F1)        | Carrier Freq Reduction Off-Delay | <input type="checkbox"/> V/f <input type="checkbox"/> CL-V/f <input type="checkbox"/> OLV <input type="checkbox"/> CLV <input type="checkbox"/> AOLV <input checked="" type="checkbox"/> OLV/PM <input type="checkbox"/> AOLV/PM <input type="checkbox"/> CLV/PM <input type="checkbox"/> EZOLV<br>Sets the length of time until the automatically reduced carrier frequency returns to the condition before the reduction.   | Determined by A1-02<br>(0.00 - 2.00 s)          | 489  |
| L8-41 (04F2)        | High Current Alarm Selection     | <input type="checkbox"/> V/f <input type="checkbox"/> CL-V/f <input type="checkbox"/> OLV <input type="checkbox"/> CLV <input type="checkbox"/> AOLV <input checked="" type="checkbox"/> OLV/PM <input type="checkbox"/> AOLV/PM <input type="checkbox"/> CLV/PM <input type="checkbox"/> EZOLV<br>Sets the function to cause an HCA [Current Alarm] when the output current is more than 150% of the drive rated current.<br>0 : No<br>1 : Yes   | 0<br>(0, 1)                                     | 489  |
| L8-51 (0471) Expert | STPo I Detection Level           | <input type="checkbox"/> V/f <input type="checkbox"/> CL-V/f <input type="checkbox"/> OLV <input type="checkbox"/> CLV <input type="checkbox"/> AOLV <input checked="" type="checkbox"/> OLV/PM <input type="checkbox"/> AOLV/PM <input type="checkbox"/> CLV/PM <input type="checkbox"/> EZOLV<br>Sets the STPo [Desynchronization Error] detection level as a percentage of the motor rated current.<br><b>Note:</b><br>Parameter A1-02 [Control Method Selection] selects which parameter is the motor rated current.<br>• A1-02 = 5 [OLV/PM]: E5-03 [Motor Rated Current (FLA)]<br>• A1-02 = 8 [EZOLV]: E9-06 [Motor Rated Current (FLA)] | 0.0%<br>(0.0 - 300.0%)                          | 489  |
| L8-52 (0472) Expert | STPo Integration Level           | <input type="checkbox"/> V/f <input type="checkbox"/> CL-V/f <input type="checkbox"/> OLV <input type="checkbox"/> CLV <input type="checkbox"/> AOLV <input checked="" type="checkbox"/> OLV/PM <input type="checkbox"/> AOLV/PM <input type="checkbox"/> CLV/PM <input type="checkbox"/> EZOLV<br>Sets the detection level for STPo [Motor Step-Out Detected] related to the ACR integral value.   | 1.0<br>(0.1 - 2.0)                              | 489  |
| L8-53 (0473) Expert | STPo Integration Time            | <input type="checkbox"/> V/f <input type="checkbox"/> CL-V/f <input type="checkbox"/> OLV <input type="checkbox"/> CLV <input type="checkbox"/> AOLV <input checked="" type="checkbox"/> OLV/PM <input type="checkbox"/> AOLV/PM <input type="checkbox"/> CLV/PM <input type="checkbox"/> EZOLV<br>Sets the length of time until the drive detects STPo after exceeding the value of L8-51 [STPo I Detection Level].  | 1.0 s<br>(1.0 - 10.0 s)                         | 490  |
| L8-54 (0474) Expert | STPo Id Diff Detection           | <input type="checkbox"/> V/f <input type="checkbox"/> CL-V/f <input type="checkbox"/> OLV <input type="checkbox"/> CLV <input type="checkbox"/> AOLV <input checked="" type="checkbox"/> OLV/PM <input type="checkbox"/> AOLV/PM <input type="checkbox"/> CLV/PM <input type="checkbox"/> EZOLV<br>Sets the Id deviation detection function for STPo [Motor Step-Out Detected].<br>0 : No<br>1 : Yes  | 1<br>(0, 1)                                     | 490  |
| L8-55 (045F)        | Internal DB TransistorProtection | <input type="checkbox"/> V/f <input type="checkbox"/> CL-V/f <input type="checkbox"/> OLV <input type="checkbox"/> CLV <input type="checkbox"/> AOLV <input checked="" type="checkbox"/> OLV/PM <input type="checkbox"/> AOLV/PM <input type="checkbox"/> CLV/PM <input type="checkbox"/> EZOLV<br>Sets the protection function for the internal braking transistor.<br>0 : Disable<br>1 : Protection Enabled   | 1<br>(0, 1)                                     | 490  |
| L8-56 (047D) Expert | Stall P @ Accel Activation Time  | <input type="checkbox"/> V/f <input type="checkbox"/> CL-V/f <input type="checkbox"/> OLV <input type="checkbox"/> CLV <input type="checkbox"/> AOLV <input checked="" type="checkbox"/> OLV/PM <input type="checkbox"/> AOLV/PM <input type="checkbox"/> CLV/PM <input type="checkbox"/> EZOLV<br>Sets the length time that the acceleration stall prevention function can continue to operate before the drive detects an STPo [Desynchronization Error].   | 5000 ms<br>(100 - 5000 ms)                      | 490  |
| L8-57 (047E) Expert | Stall Prevention Retry Counts    | <input type="checkbox"/> V/f <input type="checkbox"/> CL-V/f <input type="checkbox"/> OLV <input type="checkbox"/> CLV <input type="checkbox"/> AOLV <input checked="" type="checkbox"/> OLV/PM <input type="checkbox"/> AOLV/PM <input type="checkbox"/> CLV/PM <input type="checkbox"/> EZOLV<br>Sets the number of times the acceleration stall prevention function can operate until speeds match before the drive detects an STPo [Desynchronization Error].   | 10<br>(1 - 10 times)                            | 490  |
| L8-90 (0175) Expert | STPo Detection Level (Low Speed) | <input type="checkbox"/> V/f <input type="checkbox"/> CL-V/f <input type="checkbox"/> OLV <input type="checkbox"/> CLV <input type="checkbox"/> AOLV <input checked="" type="checkbox"/> OLV/PM <input type="checkbox"/> AOLV/PM <input type="checkbox"/> CLV/PM <input type="checkbox"/> EZOLV<br>Sets the detection level that the control fault must be equal to or more than to cause an STPo [Desynchronization Error].  | Determined by A1-02<br>(0 - 5000 times)         | 491  |
| L8-93 (073C) Expert | Low Speed Pull-out DetectionTime | <input type="checkbox"/> V/f <input type="checkbox"/> CL-V/f <input type="checkbox"/> OLV <input type="checkbox"/> CLV <input type="checkbox"/> AOLV <input checked="" type="checkbox"/> OLV/PM <input type="checkbox"/> AOLV/PM <input type="checkbox"/> CLV/PM <input type="checkbox"/> EZOLV<br>Sets the length of time the drive will wait to start baseblock after detecting LSo [Low Speed Motor Step-Out].   | 1.0 s<br>(0.0 - 10.0 s)                         | 491  |

| No. (Hex.)                | Name                            | Description   | Default (Range)      | Ref. |
|---------------------------|---------------------------------|---|----------------------|------|
| L8-94<br>(073D)<br>Expert | Low Speed Pull-out Detect Level | <b>V/f</b> <b>CL-V/f</b> <b>OLV</b> <b>CLV</b> <b>AOLV</b> <b>OLV/IPM</b> <b>AOLV/IPM</b> <b>CLV/IPM</b> <b>EZOLV</b><br>Sets the detection level for <i>LSo</i> [Low Speed Motor Step-Out] as a percentage of <i>E1-04</i> [Maximum Output Frequency]. | 3%<br>(0 - 10%)      | 491  |
| L8-95<br>(077F)<br>Expert | Low Speed Pull-out Amount       | <b>V/f</b> <b>CL-V/f</b> <b>OLV</b> <b>CLV</b> <b>AOLV</b> <b>OLV/IPM</b> <b>AOLV/IPM</b> <b>CLV/IPM</b> <b>EZOLV</b><br>Sets the average count of <i>LSo</i> [Low Speed Motor Step-Out] detections.  | 10<br>(1 - 50 times) | 491  |

## ◆ L9: Drive Protection 2

| No. (Hex.)                | Name             | Description   | Default (Range)         | Ref. |
|---------------------------|------------------|---|-------------------------|------|
| L9-16<br>(11DC)<br>Expert | FAn1 Detect Time | <b>V/f</b> <b>CL-V/f</b> <b>OLV</b> <b>CLV</b> <b>AOLV</b> <b>OLV/IPM</b> <b>AOLV/IPM</b> <b>CLV/IPM</b> <b>EZOLV</b><br>Sets the detection time for <i>FAn1</i> [Drive Cooling Fan Fault]. Yaskawa recommends that you do not change this parameter value. | 4.0 s<br>(0.0 - 30.0 s) | 491  |

## 1.12 n: Special Adjustment

### ◆ n1: Hunting Prevention

| No.<br>(Hex.)             | Name                                | Description  | Default<br>(Range)                   | Ref. |
|---------------------------|-------------------------------------|--|--------------------------------------|------|
| n1-01<br>(0580)           | Hunting Prevention Selection        | <p><input checked="" type="checkbox"/> V/f <input checked="" type="checkbox"/> CL-V/f <input type="checkbox"/> OLV <input type="checkbox"/> CLV <input type="checkbox"/> AOLV <input type="checkbox"/> OLV/PM <input type="checkbox"/> AOLV/PM <input type="checkbox"/> CLV/PM <input type="checkbox"/> EZOLV</p> <p>Sets the function to prevent hunting.<br/>0 : No<br/>1 : Yes<br/>2 : Enabled (High Carrier Frequency)</p>   | Determined by o2-04<br>(0 to 2)      | 492  |
| n1-02<br>(0581)<br>Expert | Hunting Prevention Gain Setting     | <p><input checked="" type="checkbox"/> V/f <input checked="" type="checkbox"/> CL-V/f <input type="checkbox"/> OLV <input type="checkbox"/> CLV <input type="checkbox"/> AOLV <input type="checkbox"/> OLV/PM <input type="checkbox"/> AOLV/PM <input type="checkbox"/> CLV/PM <input type="checkbox"/> EZOLV</p> <p>Sets the performance of the hunting prevention function. Usually it is not necessary to change this parameter.</p>  | 1.00<br>(0.00 - 2.50)                | 492  |
| n1-03<br>(0582)<br>Expert | Hunting Prevention Time Constant    | <p><input checked="" type="checkbox"/> V/f <input checked="" type="checkbox"/> CL-V/f <input type="checkbox"/> OLV <input type="checkbox"/> CLV <input type="checkbox"/> AOLV <input type="checkbox"/> OLV/PM <input type="checkbox"/> AOLV/PM <input type="checkbox"/> CLV/PM <input type="checkbox"/> EZOLV</p> <p>Sets the primary delay time constant of the hunting prevention function. Usually it is not necessary to change this parameter.</p>  | Determined by o2-04<br>(0 - 500 ms)  | 492  |
| n1-05<br>(0530)<br>Expert | Hunting Prevent Gain in Reverse     | <p><input checked="" type="checkbox"/> V/f <input checked="" type="checkbox"/> CL-V/f <input type="checkbox"/> OLV <input type="checkbox"/> CLV <input type="checkbox"/> AOLV <input type="checkbox"/> OLV/PM <input type="checkbox"/> AOLV/PM <input type="checkbox"/> CLV/PM <input type="checkbox"/> EZOLV</p> <p>Sets the performance of the hunting prevention function. This parameter adjusts Reverse run. Usually it is not necessary to change this parameter.</p>  | 0.00<br>(0.00 - 2.50)                | 493  |
| n1-08<br>(1105)<br>Expert | Current Detection Method            | <p><input checked="" type="checkbox"/> V/f <input checked="" type="checkbox"/> CL-V/f <input checked="" type="checkbox"/> OLV <input checked="" type="checkbox"/> CLV <input type="checkbox"/> AOLV <input type="checkbox"/> OLV/PM <input type="checkbox"/> AOLV/PM <input type="checkbox"/> CLV/PM <input type="checkbox"/> EZOLV</p> <p>Sets how the drive decreases the motor vibration that is caused by leakage current. Usually it is not necessary to change this parameter.<br/>0 : 2-Phases<br/>1 : 3-Phases</p> | 0<br>(0, 1)                          | 493  |
| n1-13<br>(1B59)<br>Expert | DC Bus Stabilization Control        | <p><input checked="" type="checkbox"/> V/f <input checked="" type="checkbox"/> CL-V/f <input type="checkbox"/> OLV <input type="checkbox"/> CLV <input type="checkbox"/> AOLV <input type="checkbox"/> OLV/PM <input type="checkbox"/> AOLV/PM <input type="checkbox"/> CLV/PM <input type="checkbox"/> EZOLV</p> <p>Sets the oscillation suppression function for the DC bus voltage.<br/>0 : No<br/>1 : Yes</p>  | 0<br>(0, 1)                          | 493  |
| n1-14<br>(1B5A)<br>Expert | DC Bus Stabilization Time           | <p><input checked="" type="checkbox"/> V/f <input checked="" type="checkbox"/> CL-V/f <input type="checkbox"/> OLV <input type="checkbox"/> CLV <input type="checkbox"/> AOLV <input type="checkbox"/> OLV/PM <input type="checkbox"/> AOLV/PM <input type="checkbox"/> CLV/PM <input type="checkbox"/> EZOLV</p> <p>Adjusts the responsiveness of the oscillation suppression function for the DC bus voltage. Set <i>n1-13 = 1 [DC Bus Stabilization Control = Enabled]</i> to enable this parameter.</p>                | 100.0 ms<br>(50.0 - 500.0 ms)        | 493  |
| n1-15<br>(0BF8)<br>Expert | PWM Voltage Offset Calibration      | <p><input checked="" type="checkbox"/> V/f <input checked="" type="checkbox"/> CL-V/f <input type="checkbox"/> OLV <input checked="" type="checkbox"/> CLV <input type="checkbox"/> AOLV <input type="checkbox"/> OLV/PM <input type="checkbox"/> AOLV/PM <input type="checkbox"/> CLV/PM <input type="checkbox"/> EZOLV</p> <p>Sets the calibration method that the drive uses to decrease torque/current ripple.<br/>0 : No<br/>1 : One Time Calibrate at Next Start<br/>2 : Calibrate Every Time at Start</p>           | Determined by A1-02<br>(0 - 2)       | 493  |
| n1-16<br>(0BFB)<br>Expert | Hunting Prevention High Fc Gain     | <p><input checked="" type="checkbox"/> V/f <input checked="" type="checkbox"/> CL-V/f <input type="checkbox"/> OLV <input type="checkbox"/> CLV <input type="checkbox"/> AOLV <input type="checkbox"/> OLV/PM <input type="checkbox"/> AOLV/PM <input type="checkbox"/> CLV/PM <input type="checkbox"/> EZOLV</p> <p>Sets the gain for the hunting prevention function. This parameter functions best with a high carrier frequency. Usually it is not necessary to change this parameter.</p>                             | Determined by o2-04<br>(0.00 - 2.50) | 494  |
| n1-17<br>(0BFC)<br>Expert | Hunting Prevent High Fc Filter      | <p><input checked="" type="checkbox"/> V/f <input checked="" type="checkbox"/> CL-V/f <input type="checkbox"/> OLV <input type="checkbox"/> CLV <input type="checkbox"/> AOLV <input type="checkbox"/> OLV/PM <input type="checkbox"/> AOLV/PM <input type="checkbox"/> CLV/PM <input type="checkbox"/> EZOLV</p> <p>Sets the responsiveness of the hunting prevention function. Usually it is not necessary to change this parameter.</p>   | 500 ms<br>(0 - 1000 ms)              | 494  |
| n1-20<br>(1588)<br>Expert | PWM Voltage Offset Calibration Time | <p><input checked="" type="checkbox"/> V/f <input checked="" type="checkbox"/> CL-V/f <input type="checkbox"/> OLV <input checked="" type="checkbox"/> CLV <input type="checkbox"/> AOLV <input type="checkbox"/> OLV/PM <input type="checkbox"/> AOLV/PM <input type="checkbox"/> CLV/PM <input type="checkbox"/> EZOLV</p> <p>Sets the calibration time at start. Usually it is not necessary to change this parameter.</p>  | 50 ms<br>(10 - 500 ms)               | 494  |



### ◆ n2: Auto Freq Regulator (AFR)

| No. (Hex.)   | Name                            | Description  | Default (Range)         | Ref. |
|--------------|---------------------------------|--|-------------------------|------|
| n2-01 (0584) | Automatic Freq Regulator Gain   | <input type="checkbox"/> V/f <input type="checkbox"/> CL-V/f <input checked="" type="checkbox"/> OLV <input type="checkbox"/> CLV <input type="checkbox"/> AOLV <input type="checkbox"/> OLV/PM <input type="checkbox"/> AOLV/PM <input type="checkbox"/> CLV/PM <input type="checkbox"/> EZOLV<br>Sets the gain of the AFR function as a magnification value. Usually it is not necessary to change this setting.   | 1.00<br>(0.00 - 10.00)  | 494  |
| n2-02 (0585) | Automatic Freq Regulator Time 1 | <input type="checkbox"/> V/f <input type="checkbox"/> CL-V/f <input checked="" type="checkbox"/> OLV <input type="checkbox"/> CLV <input type="checkbox"/> AOLV <input type="checkbox"/> OLV/PM <input type="checkbox"/> AOLV/PM <input type="checkbox"/> CLV/PM <input type="checkbox"/> EZOLV<br>Sets the time constant that sets the rate of change for the AFR function. Usually it is not necessary to change this setting.   | 50 ms<br>(0 - 2000 ms)  | 495  |
| n2-03 (0586) | Automatic Freq Regulator Time 2 | <input type="checkbox"/> V/f <input type="checkbox"/> CL-V/f <input checked="" type="checkbox"/> OLV <input type="checkbox"/> CLV <input type="checkbox"/> AOLV <input type="checkbox"/> OLV/PM <input type="checkbox"/> AOLV/PM <input type="checkbox"/> CLV/PM <input type="checkbox"/> EZOLV<br>Sets the time constant that sets the speed difference of the AFR function. Use this parameter for speed searches or regeneration. Usually it is not necessary to change this setting. | 750 ms<br>(0 - 2000 ms) | 495  |

### ◆ n3: High Slip/Overexcite Braking

| No. (Hex.)             | Name                             | Description  | Default (Range)                          | Ref. |
|------------------------|----------------------------------|--|--|------|
| n3-01 (0588)<br>Expert | HSB Deceleration Frequency Width | <input checked="" type="checkbox"/> V/f <input type="checkbox"/> CL-V/f <input type="checkbox"/> OLV <input type="checkbox"/> CLV <input type="checkbox"/> AOLV <input type="checkbox"/> OLV/PM <input type="checkbox"/> AOLV/PM <input type="checkbox"/> CLV/PM <input type="checkbox"/> EZOLV<br>Sets the amount by which the output frequency is to be lowered during high-slip braking, as a percentage of E1-04 [Maximum Output Frequency], which represents the 100% value.  | 5%<br>(1 - 20%)                          | 497  |
| n3-02 (0589)<br>Expert | HSB Current Limit Level          | <input checked="" type="checkbox"/> V/f <input type="checkbox"/> CL-V/f <input type="checkbox"/> OLV <input type="checkbox"/> CLV <input type="checkbox"/> AOLV <input type="checkbox"/> OLV/PM <input type="checkbox"/> AOLV/PM <input type="checkbox"/> CLV/PM <input type="checkbox"/> EZOLV<br>Sets the maximum current output during high-slip braking as a percentage of E2-01 [Motor Rated Current (FLA)]. Also set the current suppression to prevent exceeding drive overload tolerance.<br><b>Note:</b><br>The upper limit of the setting range changes when the setting for C6-01 [Normal / Heavy Duty Selection] changes.<br>• 150% when C6-01 = 0 [Heavy Duty Rating 1 (HD1) for Constant Torque Applications].<br>• 110% when C6-01 = 1 [Normal Duty Rating 1 (ND1) for Variable Torque Applications]. | Determined by C6-01, L8-38<br>(0 - 150%) | 497  |
| n3-03 (058A)<br>Expert | HSB Dwell Time at Stop           | <input checked="" type="checkbox"/> V/f <input type="checkbox"/> CL-V/f <input type="checkbox"/> OLV <input type="checkbox"/> CLV <input type="checkbox"/> AOLV <input type="checkbox"/> OLV/PM <input type="checkbox"/> AOLV/PM <input type="checkbox"/> CLV/PM <input type="checkbox"/> EZOLV<br>Sets the dwell time, a length of time when high-slip braking is ending and during which the motor speed decreases and runs at a stable speed. For a set length of time, the drive will hold the actual output frequency at the minimum output frequency set in E1-09.   | 1.0 s<br>(0.0 - 10.0 s)                  | 497  |
| n3-04 (058B)<br>Expert | HSB Overload Time                | <input checked="" type="checkbox"/> V/f <input type="checkbox"/> CL-V/f <input type="checkbox"/> OLV <input type="checkbox"/> CLV <input type="checkbox"/> AOLV <input type="checkbox"/> OLV/PM <input type="checkbox"/> AOLV/PM <input type="checkbox"/> CLV/PM <input type="checkbox"/> EZOLV<br>Sets the time used to detect oL7 [High Slip Braking Overload], which occurs when the output frequency does not change during high-slip braking. Usually it is not necessary to change this parameter.   | 40 s<br>(30 - 1200 s)                    | 497  |
| n3-13 (0531)           | OverexcitationBraking (OEB) Gain | <input checked="" type="checkbox"/> V/f <input type="checkbox"/> CL-V/f <input type="checkbox"/> OLV <input type="checkbox"/> CLV <input type="checkbox"/> AOLV <input type="checkbox"/> OLV/PM <input type="checkbox"/> AOLV/PM <input type="checkbox"/> CLV/PM <input type="checkbox"/> EZOLV<br>Sets the gain value that the drive multiplies by the V/f pattern output value during overexcitation deceleration to calculate the overexcitation level.   | 1.10<br>(1.00 - 1.40)                    | 498  |
| n3-14 (0532)<br>Expert | OEB High Frequency Injection     | <input checked="" type="checkbox"/> V/f <input type="checkbox"/> CL-V/f <input type="checkbox"/> OLV <input type="checkbox"/> CLV <input type="checkbox"/> AOLV <input type="checkbox"/> OLV/PM <input type="checkbox"/> AOLV/PM <input type="checkbox"/> CLV/PM <input type="checkbox"/> EZOLV<br>Sets the function that injects harmonic signals during overexcitation deceleration.<br>0 : No<br>1 : Yes  | 0<br>(0, 1)                              | 498  |
| n3-21 (0579)           | HSB Current Suppression Level    | <input checked="" type="checkbox"/> V/f <input type="checkbox"/> CL-V/f <input type="checkbox"/> OLV <input type="checkbox"/> CLV <input type="checkbox"/> AOLV <input type="checkbox"/> OLV/PM <input type="checkbox"/> AOLV/PM <input type="checkbox"/> CLV/PM <input type="checkbox"/> EZOLV<br>Sets the upper limit of the current that is suppressed at the time of overexcitation deceleration as a percentage of the drive rated current.   | 100%<br>(0 - 150%)                       | 498  |
| n3-23 (057B)           | Overexcitation Braking Operation | <input checked="" type="checkbox"/> V/f <input type="checkbox"/> CL-V/f <input type="checkbox"/> OLV <input type="checkbox"/> CLV <input type="checkbox"/> AOLV <input type="checkbox"/> OLV/PM <input type="checkbox"/> AOLV/PM <input type="checkbox"/> CLV/PM <input type="checkbox"/> EZOLV<br>Sets the direction of motor rotation where the drive will enable overexcitation.<br>0 : No<br>1 : Enabled Only when Rotating FWD<br>2 : Enabled Only when Rotating REV  | 0<br>(0 - 2)                             | 498  |

◆ n4: Adv Open Loop Vector Tune

| No. (Hex.)          | Name                             | Description  | Default (Range)                   | Ref. |
|---------------------|----------------------------------|--|-----------------------------------|------|
| n4-60 (1B80)        | Motoring Low Speed Comp Gain     | <input type="checkbox"/> V/f <input type="checkbox"/> CL-V/f <input type="checkbox"/> OLV <input type="checkbox"/> CLV <input checked="" type="checkbox"/> AOLV <input type="checkbox"/> OL/PM <input type="checkbox"/> AOLV/PM <input type="checkbox"/> CLV/PM <input type="checkbox"/> EZOLV<br>Sets a compensation gain to improve the control qualities for motoring loads in the low speed range.   | 100.0%<br>(50.0 - 200.0%)         | 499  |
| n4-61 (1B81)        | Low Speed Comp Frequency Level   | <input type="checkbox"/> V/f <input type="checkbox"/> CL-V/f <input type="checkbox"/> OLV <input type="checkbox"/> CLV <input checked="" type="checkbox"/> AOLV <input type="checkbox"/> OL/PM <input type="checkbox"/> AOLV/PM <input type="checkbox"/> CLV/PM <input type="checkbox"/> EZOLV<br>Sets a frequency at which the settings n4-60 [Motoring Low Speed Comp Gain] and n4-62 [Regen Low Speed Comp Gain] are enabled. When the output frequency < n4-61, the drive adjusts the torque to agree with the settings for n4-60 and n4-62. Usually it is not necessary to change this setting.                       | 6.00 Hz<br>(0.50 - 12.00 Hz)      | 499  |
| n4-62 (1B82)        | Regen Low Speed Comp Gain        | <input type="checkbox"/> V/f <input type="checkbox"/> CL-V/f <input type="checkbox"/> OLV <input type="checkbox"/> CLV <input checked="" type="checkbox"/> AOLV <input type="checkbox"/> OL/PM <input type="checkbox"/> AOLV/PM <input type="checkbox"/> CLV/PM <input type="checkbox"/> EZOLV<br>Sets a compensation gain to improve the control qualities for regenerative loads in the low speed range.   | 100.0<br>(50.0 - 500.0)           | 499  |
| n4-63 (1B83)        | Speed EstimateResponse@High Freq | <input type="checkbox"/> V/f <input type="checkbox"/> CL-V/f <input type="checkbox"/> OLV <input type="checkbox"/> CLV <input checked="" type="checkbox"/> AOLV <input type="checkbox"/> OL/PM <input type="checkbox"/> AOLV/PM <input type="checkbox"/> CLV/PM <input type="checkbox"/> EZOLV<br>Sets the responsiveness of the speed estimation in high speed ranges, where the output frequency is ≥ n4-67 [Estimate Gain Switchover Freq].   | 60.0<br>(0.1 - 300.0)             | 499  |
| n4-64 (1B84)        | Speed Estimate Response@Low Freq | <input type="checkbox"/> V/f <input type="checkbox"/> CL-V/f <input type="checkbox"/> OLV <input type="checkbox"/> CLV <input checked="" type="checkbox"/> AOLV <input type="checkbox"/> OL/PM <input type="checkbox"/> AOLV/PM <input type="checkbox"/> CLV/PM <input type="checkbox"/> EZOLV<br>Sets the responsiveness of the speed estimation in low speed ranges, where 0 ≤ the output frequency, which is < n4-67 [Estimate Gain Switchover Freq].   | 60.0<br>(0.1 - 300.0)             | 500  |
| n4-65 (1B85)        | Flux Estimate Response@High Freq | <input type="checkbox"/> V/f <input type="checkbox"/> CL-V/f <input type="checkbox"/> OLV <input checked="" type="checkbox"/> CLV <input checked="" type="checkbox"/> AOLV <input type="checkbox"/> OL/PM <input type="checkbox"/> AOLV/PM <input type="checkbox"/> CLV/PM <input type="checkbox"/> EZOLV<br>Sets the responsiveness of the magnetic flux estimation in high speed ranges, where the output frequency is ≥ n4-67 [Estimate Gain Switchover Freq]. Usually it is not necessary to change this setting.  | 1.00<br>(0.50 - 3.00)             | 500  |
| n4-66 (1B86)        | Flux Estimate Response @Low Freq | <input type="checkbox"/> V/f <input type="checkbox"/> CL-V/f <input type="checkbox"/> OLV <input checked="" type="checkbox"/> CLV <input checked="" type="checkbox"/> AOLV <input type="checkbox"/> OL/PM <input type="checkbox"/> AOLV/PM <input type="checkbox"/> CLV/PM <input type="checkbox"/> EZOLV<br>Sets the responsiveness of the magnetic flux estimation in low speed ranges, where 0 ≤ the output frequency, which is < n4-67 [Estimate Gain Switchover Freq]. Usually it is not necessary to change this setting.  | 1.50<br>(0.50 - 3.00)             | 500  |
| n4-67 (1B87)        | Estimate Gain Switchover Freq    | <input type="checkbox"/> V/f <input type="checkbox"/> CL-V/f <input type="checkbox"/> OLV <input checked="" type="checkbox"/> CLV <input checked="" type="checkbox"/> AOLV <input type="checkbox"/> OL/PM <input type="checkbox"/> AOLV/PM <input type="checkbox"/> CLV/PM <input type="checkbox"/> EZOLV<br>Sets the switching frequency for estimation gain for these parameters:<br>n4-63 [Speed EstimateResponse@High Freq]<br>n4-64 [Speed Estimate Response@Low Freq]<br>n4-65 [Flux Estimate Response@High Freq]<br>n4-66 [Flux Estimate Response @Low Freq]<br>Usually it is not necessary to change this setting. | 6.00 Hz<br>(0.00 - E1-04 setting) | 500  |
| n4-68 (1B88)        | Speed Estimation Filter Time     | <input type="checkbox"/> V/f <input type="checkbox"/> CL-V/f <input type="checkbox"/> OLV <input type="checkbox"/> CLV <input checked="" type="checkbox"/> AOLV <input type="checkbox"/> OL/PM <input type="checkbox"/> AOLV/PM <input type="checkbox"/> CLV/PM <input type="checkbox"/> EZOLV<br>Sets the primary delay time constant for the speed estimation value. Usually it is not necessary to change this setting.   | 0.001 s<br>(0.001 - 0.010 s)      | 500  |
| n4-69 (1B89)        | Flux Control Response            | <input type="checkbox"/> V/f <input type="checkbox"/> CL-V/f <input type="checkbox"/> OLV <input type="checkbox"/> CLV <input checked="" type="checkbox"/> AOLV <input type="checkbox"/> OL/PM <input type="checkbox"/> AOLV/PM <input type="checkbox"/> CLV/PM <input type="checkbox"/> EZOLV<br>Unifies control of magnetic flux to make motor vibrations more stable.   | 1.00<br>(0.00 - 60.00)            | 501  |
| n4-70 (1B8A)        | Speed Command Comp @ Low Freq    | <input type="checkbox"/> V/f <input type="checkbox"/> CL-V/f <input type="checkbox"/> OLV <input type="checkbox"/> CLV <input checked="" type="checkbox"/> AOLV <input type="checkbox"/> OL/PM <input type="checkbox"/> AOLV/PM <input type="checkbox"/> CLV/PM <input type="checkbox"/> EZOLV<br>Sets the function to make the drive more stable when operating at low speeds. Usually it is not necessary to change this setting.  | 1.00 Hz<br>(0.00 - 6.00 Hz)       | 501  |
| n4-71 (1B8B) Expert | Flux Estimation Method           | <input type="checkbox"/> V/f <input type="checkbox"/> CL-V/f <input type="checkbox"/> OLV <input type="checkbox"/> CLV <input checked="" type="checkbox"/> AOLV <input type="checkbox"/> OL/PM <input type="checkbox"/> AOLV/PM <input type="checkbox"/> CLV/PM <input type="checkbox"/> EZOLV<br>Sets the flux estimation method. Usually it is not necessary to change this setting.<br>0 : Method 1<br>1 : Method 2   | 0<br>(0, 1)                       | 501  |
| n4-72 (1B8C)        | Speed Feedback Mode              | <input type="checkbox"/> V/f <input type="checkbox"/> CL-V/f <input type="checkbox"/> OLV <input type="checkbox"/> CLV <input checked="" type="checkbox"/> AOLV <input type="checkbox"/> OL/PM <input type="checkbox"/> AOLV/PM <input type="checkbox"/> CLV/PM <input type="checkbox"/> EZOLV<br>Sets the requirement for an encoder option when A1-02 = 4 [Control Method Selection = Advanced Open Loop Vector].<br>0 : Without Encoder<br>1 : With Encoder   | 0<br>(0, 1)                       | 501  |
| n4-73 (1B8D)        | PGo Recovery Selection           | <input type="checkbox"/> V/f <input type="checkbox"/> CL-V/f <input type="checkbox"/> OLV <input type="checkbox"/> CLV <input checked="" type="checkbox"/> AOLV <input type="checkbox"/> OL/PM <input type="checkbox"/> AOLV/PM <input type="checkbox"/> CLV/PM <input type="checkbox"/> EZOLV<br>Sets the restart mode to Without Encoder Mode or the With Encoder Mode when an encoder is disconnected.<br>0 : Without Encoder<br>1 : With Encoder   | 0<br>(0, 1)                       | 501  |
| n4-74 (1B8E)        | Limit of Flux Loop               | <input type="checkbox"/> V/f <input type="checkbox"/> CL-V/f <input type="checkbox"/> OLV <input type="checkbox"/> CLV <input checked="" type="checkbox"/> AOLV <input type="checkbox"/> OL/PM <input type="checkbox"/> AOLV/PM <input type="checkbox"/> CLV/PM <input type="checkbox"/> EZOLV<br>Sets the control level for flux loop control output.   | 250%<br>(100 - 500%)              | 502  |

### ◆ n5: Feed Forward Control

| No. (Hex.)                       | Name                            | Description  | Default (Range)   | Ref. |
|----------------------------------|---------------------------------|--|---|------|
| n5-01<br>(05B0)                  | Feed Forward Control Selection  | <input type="checkbox"/> V/f <input type="checkbox"/> CL-V/f <input type="checkbox"/> OLV <input checked="" type="checkbox"/> CLV <input type="checkbox"/> AOLV <input type="checkbox"/> OLV/PM <input type="checkbox"/> AOLV/PM <input type="checkbox"/> CLV/PM <input type="checkbox"/> EZOLV<br>Sets the feed forward function.<br>0 : No<br>1 : Yes  | 0<br>(0, 1)   | 503  |
| n5-02<br>(05B1)                  | Motor Inertia Acceleration Time | <input type="checkbox"/> V/f <input type="checkbox"/> CL-V/f <input type="checkbox"/> OLV <input checked="" type="checkbox"/> CLV <input type="checkbox"/> AOLV <input type="checkbox"/> OLV/PM <input type="checkbox"/> AOLV/PM <input type="checkbox"/> CLV/PM <input type="checkbox"/> EZOLV<br>Sets the length of time for the motor to accelerate from the stopped to the maximum frequency with a single motor at the rated torque. Inertia Tuning automatically sets the motor acceleration time. | Determined by C6-01, E5-01, and o2-04<br>(0.001 - 10.000 s) | 503  |
| n5-03<br>(05B2)                  | Feed Forward Control Gain       | <input type="checkbox"/> V/f <input type="checkbox"/> CL-V/f <input type="checkbox"/> OLV <input checked="" type="checkbox"/> CLV <input type="checkbox"/> AOLV <input type="checkbox"/> OLV/PM <input type="checkbox"/> AOLV/PM <input type="checkbox"/> CLV/PM <input type="checkbox"/> EZOLV<br>Sets the ratio between load inertia and motor inertia. Inertia Tuning automatically sets the Feedforward Control Gain value.  | 1.00<br>(0.00 - 100.00)                                     | 504  |
| n5-04<br>(05B3)<br>RUN<br>Expert | Speed Response Frequency        | <input type="checkbox"/> V/f <input type="checkbox"/> CL-V/f <input type="checkbox"/> OLV <input checked="" type="checkbox"/> CLV <input type="checkbox"/> AOLV <input type="checkbox"/> OLV/PM <input type="checkbox"/> AOLV/PM <input type="checkbox"/> CLV/PM <input type="checkbox"/> EZOLV<br>Sets the response frequency for the speed reference. Usually it is not necessary to change this parameter.  | Determined by A1-02<br>(0.00 - 500.00 Hz)                   | 505  |

### ◆ n6: Online Tuning

| No. (Hex.)                | Name                     | Description  | Default (Range)          | Ref. |
|---------------------------|--------------------------|--|--------------------------|------|
| n6-01<br>(0570)           | Online Tuning Selection  | <input type="checkbox"/> V/f <input type="checkbox"/> CL-V/f <input checked="" type="checkbox"/> OLV <input type="checkbox"/> CLV <input type="checkbox"/> AOLV <input type="checkbox"/> OLV/PM <input type="checkbox"/> AOLV/PM <input type="checkbox"/> CLV/PM <input type="checkbox"/> EZOLV<br>Sets the type of motor data that Online Tuning uses for OLV control.<br>0 : No<br>1 : Line-to-Line Resistance Tuning<br>2 : Voltage Correction Tuning                   | 0<br>(0 - 2)             | 505  |
| n6-05<br>(05C7)<br>Expert | Online Tuning Gain       | <input type="checkbox"/> V/f <input type="checkbox"/> CL-V/f <input checked="" type="checkbox"/> OLV <input type="checkbox"/> CLV <input type="checkbox"/> AOLV <input type="checkbox"/> OLV/PM <input type="checkbox"/> AOLV/PM <input type="checkbox"/> CLV/PM <input type="checkbox"/> EZOLV<br>Sets the compensation gain when $n6-01 = 2$ [Online Tuning Selection = Voltage Correction Tuning]. Usually it is not necessary to change this parameter.                | 1.0<br>(0.1 - 50.0)      | 505  |
| n6-11<br>(1B56)<br>Expert | Online Resistance Tuning | <input type="checkbox"/> V/f <input type="checkbox"/> CL-V/f <input type="checkbox"/> OLV <input checked="" type="checkbox"/> CLV <input type="checkbox"/> AOLV <input type="checkbox"/> OLV/PM <input type="checkbox"/> AOLV/PM <input type="checkbox"/> CLV/PM <input type="checkbox"/> EZOLV<br>Sets the responsiveness for online resistor tuning. Set this parameter to approximately 1.000 to enable the function. The function is disabled when the value is 0.000. | 0.000<br>(0.000 - 1.000) | 505  |

### ◆ n7: EZ Drive

| No. (Hex.)                | Name                             | Description   | Default (Range)            | Ref. |
|---------------------------|----------------------------------|---|----------------------------|------|
| n7-01<br>(3111)<br>Expert | Damping Gain for Low Frequency   | <input type="checkbox"/> V/f <input type="checkbox"/> CL-V/f <input type="checkbox"/> OLV <input type="checkbox"/> CLV <input type="checkbox"/> AOLV <input type="checkbox"/> OLV/PM <input type="checkbox"/> AOLV/PM <input type="checkbox"/> CLV/PM <input checked="" type="checkbox"/> EZOLV<br>Sets the oscillation suppression gain for the low speed range.   | 1.0<br>(0.1 - 10.0)        | 506  |
| n7-05<br>(3115)<br>Expert | Response Gain for Load Changes   | <input type="checkbox"/> V/f <input type="checkbox"/> CL-V/f <input type="checkbox"/> OLV <input type="checkbox"/> CLV <input type="checkbox"/> AOLV <input type="checkbox"/> OLV/PM <input type="checkbox"/> AOLV/PM <input type="checkbox"/> CLV/PM <input checked="" type="checkbox"/> EZOLV<br>Sets the response gain related to changes in the load.   | 100<br>(10 - 1000)         | 506  |
| n7-07<br>(3117)<br>Expert | Speed Calculation Gain1          | <input type="checkbox"/> V/f <input type="checkbox"/> CL-V/f <input type="checkbox"/> OLV <input type="checkbox"/> CLV <input type="checkbox"/> AOLV <input type="checkbox"/> OLV/PM <input type="checkbox"/> AOLV/PM <input type="checkbox"/> CLV/PM <input checked="" type="checkbox"/> EZOLV<br>Sets the speed calculation gain during usual operation. Usually it is not necessary to change this setting.  | 15.0 Hz<br>(1.0 - 50.0 Hz) | 506  |
| n7-08<br>(3118)<br>Expert | Speed Calculation Gain2          | <input type="checkbox"/> V/f <input type="checkbox"/> CL-V/f <input type="checkbox"/> OLV <input type="checkbox"/> CLV <input type="checkbox"/> AOLV <input type="checkbox"/> OLV/PM <input type="checkbox"/> AOLV/PM <input type="checkbox"/> CLV/PM <input checked="" type="checkbox"/> EZOLV<br>Sets the speed calculation gain during a speed search.   | 25.0 Hz<br>(1.0 - 50.0 Hz) | 506  |
| n7-10<br>(311A)<br>Expert | Pull-in Current Switching Speed  | <input type="checkbox"/> V/f <input type="checkbox"/> CL-V/f <input type="checkbox"/> OLV <input type="checkbox"/> CLV <input type="checkbox"/> AOLV <input type="checkbox"/> OLV/PM <input type="checkbox"/> AOLV/PM <input type="checkbox"/> CLV/PM <input checked="" type="checkbox"/> EZOLV<br>Sets a speed range proportional to the rated frequency that enables pull-in current commands.  | 10.0%<br>(0.0 - 100.0%)    | 506  |
| n7-17<br>(3122)           | Resistance TemperatureCorrection | <input type="checkbox"/> V/f <input type="checkbox"/> CL-V/f <input type="checkbox"/> OLV <input type="checkbox"/> CLV <input type="checkbox"/> AOLV <input type="checkbox"/> OLV/PM <input type="checkbox"/> AOLV/PM <input type="checkbox"/> CLV/PM <input checked="" type="checkbox"/> EZOLV<br>Sets the function to adjust for changes in the motor resistance value caused by changes in the temperature.<br>0 : No<br>1 : Valid (Only 1 time)<br>2 : Valid (Every time) | 1<br>(0 to 2)              | 507  |

◆ n8: PM Motor Control Tuning

| No. (Hex.)          | Name                             | Description  | Default (Range)                       | Ref. |
|---------------------|----------------------------------|--|---------------------------------------|------|
| n8-01 (0540) Expert | Pole Position Detection Current  | <span>V/f</span> <span>CL-V/f</span> <span>OLV</span> <span>CLV</span> <span>AOLV</span> <span>OLV/PM</span> <span>AOLV/PM</span> <span>CLV/PM</span> <span>EZOLV</span><br>Sets, as a percentage, the Initial Rotor Position Estimated Current, taking the E5-03 [Motor Rated Current (FLA)] as the 100% value. Usually it is not necessary to change this setting.   | 50%<br>(0 - 100%)                     | 507  |
| n8-02 (0541) Expert | Pole Alignment Current Level     | <span>V/f</span> <span>CL-V/f</span> <span>OLV</span> <span>CLV</span> <span>AOLV</span> <span>OLV/PM</span> <span>AOLV/PM</span> <span>CLV/PM</span> <span>EZOLV</span><br>Sets the current at the time of polar attraction as a percentage of E5-03 [Motor Rated Current (FLA)]. Usually it is not necessary to change this setting.   | 80%<br>(0 - 150%)                     | 507  |
| n8-03 (0542)        | Pole Position Detection Time     | <span>V/f</span> <span>CL-V/f</span> <span>OLV</span> <span>CLV</span> <span>AOLV</span> <span>OLV/PM</span> <span>AOLV/PM</span> <span>CLV/PM</span> <span>EZOLV</span><br>Sets the length of the Current Starting Time, which is used for Z Pulse Offset Tuning. Usually it is not necessary to change this setting.   | 1.5 s<br>(1.5 - 5.0 s)                | 507  |
| n8-04 (0543) Expert | Pole Alignment Time              | <span>V/f</span> <span>CL-V/f</span> <span>OLV</span> <span>CLV</span> <span>AOLV</span> <span>OLV/PM</span> <span>AOLV/PM</span> <span>CLV/PM</span> <span>EZOLV</span><br>Sets the length of the Polar Attraction Time, which is used for Z Pulse Offset Tuning. Usually it is not necessary to change this setting.   | 1.5 s<br>(1.5 - 5.0 s)                | 508  |
| n8-11 (054A)        | Observer Calculation Gain 2      | <span>V/f</span> <span>CL-V/f</span> <span>OLV</span> <span>CLV</span> <span>AOLV</span> <span>OLV/PM</span> <span>AOLV/PM</span> <span>CLV/PM</span> <span>EZOLV</span><br>Sets the gain for speed estimation. Usually it is not necessary to change this setting.  | Determined by n8-72<br>(0.0 - 1000.0) | 508  |
| n8-14 (054D) Expert | Polarity Compensation Gain 3     | <span>V/f</span> <span>CL-V/f</span> <span>OLV</span> <span>CLV</span> <span>AOLV</span> <span>OLV/PM</span> <span>AOLV/PM</span> <span>CLV/PM</span> <span>EZOLV</span><br>Sets the gain for speed estimation. Usually it is not necessary to change this setting.  | 1.000<br>(0.000 - 10.000)             | 508  |
| n8-15 (054E) Expert | Polarity Compensation Gain 4     | <span>V/f</span> <span>CL-V/f</span> <span>OLV</span> <span>CLV</span> <span>AOLV</span> <span>OLV/PM</span> <span>AOLV/PM</span> <span>CLV/PM</span> <span>EZOLV</span><br>Sets the gain for speed estimation. Usually it is not necessary to change this setting.  | 0.500<br>(0.000 - 10.000)             | 508  |
| n8-21 (0554) Expert | Motor Back-EMF (Ke) Gain         | <span>V/f</span> <span>CL-V/f</span> <span>OLV</span> <span>CLV</span> <span>AOLV</span> <span>OLV/PM</span> <span>AOLV/PM</span> <span>CLV/PM</span> <span>EZOLV</span><br>Sets the gain for speed estimation. Usually it is not necessary to change this setting.  | 0.90<br>(0.80 - 1.00)                 | 508  |
| n8-23 (0556) Expert | Polarity ACR q Gain              | <span>V/f</span> <span>CL-V/f</span> <span>OLV</span> <span>CLV</span> <span>AOLV</span> <span>OLV/PM</span> <span>AOLV/PM</span> <span>CLV/PM</span> <span>EZOLV</span><br>Sets the proportional gain for current regulator q-axis control when estimating initial pole. Usually it is not necessary to change this setting.  | 0<br>(0 - 2000)                       | 508  |
| n8-24 (0557) Expert | Polarity ACR qI Time             | <span>V/f</span> <span>CL-V/f</span> <span>OLV</span> <span>CLV</span> <span>AOLV</span> <span>OLV/PM</span> <span>AOLV/PM</span> <span>CLV/PM</span> <span>EZOLV</span><br>Sets the integral time for current regulator q-axis control when estimating initial pole. Usually it is not necessary to change this setting.  | 0.0 ms<br>(0.0 - 100.0)               | 509  |
| n8-25 (0558) Expert | Polarity ACR q Limit             | <span>V/f</span> <span>CL-V/f</span> <span>OLV</span> <span>CLV</span> <span>AOLV</span> <span>OLV/PM</span> <span>AOLV/PM</span> <span>CLV/PM</span> <span>EZOLV</span><br>Sets the q-axis limit of the current regulator when estimating initial pole. Usually it is not necessary to change this setting.   | 0%<br>(0 - 150)                       | 509  |
| n8-26 (0559) Expert | Polarity ACR d Gain              | <span>V/f</span> <span>CL-V/f</span> <span>OLV</span> <span>CLV</span> <span>AOLV</span> <span>OLV/PM</span> <span>AOLV/PM</span> <span>CLV/PM</span> <span>EZOLV</span><br>Sets the proportional gain for current regulator d-axis control when estimating initial pole. Usually it is not necessary to change this setting.  | 500<br>(0 - 2000)                     | 509  |
| n8-27 (055A) Expert | Polarity ACR dI Time             | <span>V/f</span> <span>CL-V/f</span> <span>OLV</span> <span>CLV</span> <span>AOLV</span> <span>OLV/PM</span> <span>AOLV/PM</span> <span>CLV/PM</span> <span>EZOLV</span><br>Sets the integral time for current regulator d-axis control when estimating initial pole. Usually it is not necessary to change this setting.  | 0.0 ms<br>(0.0 - 100.0)               | 509  |
| n8-28 (055B) Expert | Polarity ACR d Limit             | <span>V/f</span> <span>CL-V/f</span> <span>OLV</span> <span>CLV</span> <span>AOLV</span> <span>OLV/PM</span> <span>AOLV/PM</span> <span>CLV/PM</span> <span>EZOLV</span><br>Sets the d-axis limit of the current regulator when estimating initial pole. Usually it is not necessary to change this setting.   | 100%<br>(0 - 150)                     | 509  |
| n8-35 (0562)        | Initial Pole Detection Method    | <span>V/f</span> <span>CL-V/f</span> <span>OLV</span> <span>CLV</span> <span>AOLV</span> <span>OLV/PM</span> <span>AOLV/PM</span> <span>CLV/PM</span> <span>EZOLV</span><br>Sets how the drive detects the position of the rotor at start.<br><b>Note:</b><br>• When you operate an SPM motor, set n8-35 = 0. When you operate an IPM motor, you can set n8-35 = 0 to 2.<br>• When you want to set n8-35 = 1, perform High Frequency Injection Auto-Tuning.<br>0 : Pull-in<br>1 : High Frequency Injection<br>2 : Pulse Injection  | Determined by A1-02<br>(0 - 2)        | 509  |
| n8-36 (0563)        | HFI Frequency Level for L Tuning | <span>V/f</span> <span>CL-V/f</span> <span>OLV</span> <span>CLV</span> <span>AOLV</span> <span>OLV/PM</span> <span>AOLV/PM</span> <span>CLV/PM</span> <span>EZOLV</span><br>Sets the injection frequency for high frequency injection.<br><b>Note:</b><br>• Set n8-35 = 1 [Initial Pole Detection Method = High Frequency Injection] or n8-57 = 1 [HFI Overlap Selection = Enabled] to enable this parameter.<br>• The drive automatically calculates this value when High Frequency Injection Auto-Tuning completes successfully. | 500 Hz<br>(200 - 1000 Hz)             | 510  |

| No. (Hex.)          | Name   | Description  | Default (Range)                           | Ref. |
|---------------------|--|--|---|------|
| n8-37 (0564) Expert | HFI Voltage Amplitude Level  | <p>V/f CL-V/f OLV CLV AOLV <b>OLV/PM</b> AOLV/PM CLV/PM EZOLV</p> <p>Sets the high frequency injection amplitude as a percentage where 200 V = 100% for 200 V class drives and 400 V = 100% for a 400 V class drives. Usually it is not necessary to change this setting.</p> <p><b>Note:</b></p> <ul style="list-style-type: none"> <li>Set <math>n8-35 = 1</math> [Initial Pole Detection Method = High Frequency Injection] or <math>n8-57 = 1</math> [HFI Overlap Selection = Enabled] to enable this parameter.</li> <li>The drive automatically calculates this value when High Frequency Injection Auto-Tuning completes successfully.</li> </ul> | 20.0%<br>(0.0 - 50.0%)                    | 510  |
| n8-39 (0566)        | Low-Pass Filter Shut-Off Frequency for High Frequency Injection      | <p>V/f CL-V/f OLV CLV AOLV <b>OLV/PM</b> AOLV/PM CLV/PM EZOLV</p> <p>Sets the low-pass filter shut-off frequency for high frequency injection.</p> <p><b>Note:</b></p> <ul style="list-style-type: none"> <li>Set <math>n8-35 = 1</math> [Initial Pole Detection Method = High Frequency Injection] or <math>n8-57 = 1</math> [HFI Overlap Selection = Enabled] to enable this parameter.</li> <li>The drive automatically calculates this value when High Frequency Injection Auto-Tuning completes successfully.</li> </ul>  | 250 Hz<br>(0 - 1000 Hz)                   | 510  |
| n8-41 (0568) Expert | Response Gain for High Frequency Injection Speed Estimation          | <p>V/f CL-V/f OLV CLV AOLV <b>OLV/PM</b> AOLV/PM CLV/PM EZOLV</p> <p>Sets the response gain for the high frequency injection speed estimation.</p>   | 2.5<br>(-10.0 - +10.0)                    | 510  |
| n8-42 (0569) Expert | Integral Time Constant for High Frequency Injection Speed Estimation | <p>V/f CL-V/f OLV CLV AOLV <b>OLV/PM</b> AOLV/PM CLV/PM EZOLV</p> <p>Sets the integral time constant for the high frequency injection speed estimation. Usually it is not necessary to change this setting.</p>  | 0.10 s<br>(0.00 - 9.99 s)                 | 511  |
| n8-45 (0538)        | Speed Feedback Detection Gain  | <p>V/f CL-V/f OLV CLV AOLV <b>OLV/PM</b> AOLV/PM CLV/PM EZOLV</p> <p>Sets the internal speed feedback detection reduction unit gain as a magnification value. Usually it is not necessary to change this setting.</p>  | 0.80<br>(0.00 - 10.00)                    | 511  |
| n8-46 (0539) Expert | Phase Compensation Gain  | <p>V/f CL-V/f OLV CLV AOLV <b>OLV/PM</b> AOLV/PM CLV/PM EZOLV</p> <p>Sets the gain to compensate for phase differences. Usually it is not necessary to change this setting.</p>  | 0.3<br>(0.0 - 10.0)                       | 511  |
| n8-47 (053A)        | Pull-in Current Comp Filter Time                                     | <p>V/f CL-V/f OLV CLV AOLV <b>OLV/PM</b> AOLV/PM CLV/PM EZOLV</p> <p>Sets the time constant the drive uses to align the pull-in current reference value with the actual current value. Usually it is not necessary to change this setting.</p>   | 5.0 s<br>(0.0 - 100.0 s)                  | 511  |
| n8-48 (053B)        | Pull-in/Light Load Id Current  | <p>V/f CL-V/f OLV CLV AOLV <b>OLV/PM</b> AOLV/PM CLV/PM EZOLV</p> <p>On the basis that parameter <math>E5-03</math> [Motor Rated Current (FLA)] is the 100% value, this parameter sets the d-axis current that flows to the motor during run at constant speed as a percentage.</p>  | 30%<br>(0 - 200%)                         | 511  |
| n8-49 (053C)        | d-Axis Cur forHighEfficiencyCont                                     | <p>V/f CL-V/f OLV CLV AOLV <b>OLV/PM</b> AOLV/PM CLV/PM EZOLV</p> <p>Sets the d-axis current to that the drive will supply to the motor to run it at a constant speed with a heavy load. Considers <math>E5-03</math> [PM Motor Rated Current (FLA)] to be 100%. Usually it is not necessary to change this setting.</p>   | Determined by E5-01<br>(-200.0 - +200.0%) | 512  |
| n8-50 (053D)        | Heavy Duty I Level   | <p>V/f CL-V/f OLV CLV AOLV <b>OLV/PM</b> AOLV/PM CLV/PM EZOLV</p> <p>Sets the load current level to start high efficiency control as a percentage of <math>E5-03</math> [Motor Rated Current]. Usually it is not necessary to change this setting.</p>   | 80%<br>(50 - 255)                         | 512  |
| n8-51 (053E)        | Pull-in Current @ Acceleration                                       | <p>V/f CL-V/f OLV CLV AOLV <b>OLV/PM</b> AOLV/PM CLV/PM EZOLV</p> <p>Sets the pull-in current allowed to flow during acceleration/deceleration as a percentage of the motor rated current.</p> <p><b>Note:</b></p> <ul style="list-style-type: none"> <li>Parameter <math>A1-02</math> [Control Method Selection] selects which parameter is the motor rated current.</li> <li><math>A1-02 = 5</math> [OLV/PM]: <math>E5-03</math> [Motor Rated Current (FLA)]</li> <li><math>A1-02 = 8</math> [EZOLV]: <math>E9-06</math> [Motor Rated Current (FLA)]</li> </ul>  | Determined by A1-02<br>(0 - 200%)         | 512  |
| n8-52 (053F) Expert | ACR Proportional Gain  | <p>V/f CL-V/f OLV CLV AOLV <b>OLV/PM</b> AOLV/PM CLV/PM EZOLV</p> <p>Sets the proportional gain of the current regulator. Usually it is not necessary to change this setting.</p>  | 10.0<br>(-100.0 - 100.0)                  | 512  |
| n8-54 (056D) Expert | Voltage Error Compensation Time                                      | <p>V/f CL-V/f OLV CLV AOLV <b>OLV/PM</b> AOLV/PM CLV/PM EZOLV</p> <p>Sets the time constant that the drive uses when adjusting for voltage errors.</p>   | 1.00 s<br>(0.00 - 10.00 s)                | 512  |
| n8-55 (056E)        | Motor to Load Inertia Ratio  | <p>V/f CL-V/f OLV CLV AOLV <b>OLV/PM</b> AOLV/PM CLV/PM EZOLV</p> <p>Sets the ratio between motor inertia and machine inertia.</p> <p>0 : Below 1:10<br/>1 : Between 1:10 and 1:30<br/>2 : Between 1:30 and 1:50<br/>3 : Beyond 1:50</p>   | 0<br>(0 - 3)                              | 513  |

## 1.12 n: Special Adjustment

| No. (Hex.)          | Name                                    | Description   | Default (Range)  | Ref. |
|---------------------|---|---|--|------|
| n8-56 (056F) Expert | Voltage Compensation Control Selection  | <input type="checkbox"/> V/f <input type="checkbox"/> CL-V/f <input type="checkbox"/> OLV <input type="checkbox"/> CLV <input type="checkbox"/> AOLV <input checked="" type="checkbox"/> OLV/PM <input type="checkbox"/> AOLV/PM <input type="checkbox"/> CLV/PM <input type="checkbox"/> EZOLV<br>Sets the high efficiency control method for IPM motor. Usually it is not necessary to change this setting.<br>0 : No<br>1 : Enabled (Vd)<br>2 : Enabled (Vd&Vq)  | 1<br>(0 - 2)   | 513  |
| n8-57 (0574)        | HFI Overlap Selection                   | <input type="checkbox"/> V/f <input type="checkbox"/> CL-V/f <input type="checkbox"/> OLV <input type="checkbox"/> CLV <input type="checkbox"/> AOLV <input type="checkbox"/> OLV/PM <input checked="" type="checkbox"/> AOLV/PM <input type="checkbox"/> CLV/PM <input type="checkbox"/> EZOLV<br>Sets the function that detects motor speed with high frequency injection.<br><b>Note:</b><br>When you want to set <i>n8-57</i> = 1, perform High Frequency Injection Auto-Tuning.<br>0 : Disabled<br>1 : Enabled | 0<br>(0, 1)  | 513  |
| n8-62 (057D) Expert | Output Voltage Limit Level              | <input type="checkbox"/> V/f <input type="checkbox"/> CL-V/f <input type="checkbox"/> OLV <input type="checkbox"/> CLV <input type="checkbox"/> AOLV <input checked="" type="checkbox"/> OLV/PM <input checked="" type="checkbox"/> AOLV/PM <input type="checkbox"/> CLV/PM <input type="checkbox"/> EZOLV<br>Sets the output voltage limit to prevent saturation of the output voltage. Usually it is not necessary to change this parameter.  | 200 V Class: 200.0 V, 400 V: 400.0 V<br>(200 V Class: 0.0 to 240.0 V, 400 V Class: 0.0 to 480.0 V) | 514  |
| n8-63 (057E) Expert | Output V Proportional Gain              | <input type="checkbox"/> V/f <input type="checkbox"/> CL-V/f <input type="checkbox"/> OLV <input type="checkbox"/> CLV <input type="checkbox"/> AOLV <input checked="" type="checkbox"/> OLV/PM <input checked="" type="checkbox"/> AOLV/PM <input type="checkbox"/> CLV/PM <input type="checkbox"/> EZOLV<br>Sets the proportional gain for output voltage control. Usually it is not necessary to change this setting.  | 1.00<br>(0.00 - 100.00)  | 514  |
| n8-64 (057F) Expert | Output V Integral Time                  | <input type="checkbox"/> V/f <input type="checkbox"/> CL-V/f <input type="checkbox"/> OLV <input type="checkbox"/> CLV <input type="checkbox"/> AOLV <input checked="" type="checkbox"/> OLV/PM <input checked="" type="checkbox"/> AOLV/PM <input type="checkbox"/> CLV/PM <input type="checkbox"/> EZOLV<br>Sets the integral time for output voltage control. Usually it is not necessary to change this setting.  | 0.040 s<br>(0.000 - 5.000)   | 514  |
| n8-65 (065C) Expert | Speed Fdbk Gain @ oV Suppression        | <input type="checkbox"/> V/f <input type="checkbox"/> CL-V/f <input type="checkbox"/> OLV <input type="checkbox"/> CLV <input type="checkbox"/> AOLV <input checked="" type="checkbox"/> OLV/PM <input type="checkbox"/> AOLV/PM <input type="checkbox"/> CLV/PM <input type="checkbox"/> EZOLV<br>Sets the gain of internal speed feedback detection suppression while the overvoltage suppression function is operating as a magnification value. Usually it is not necessary to change this parameter.           | 1.50<br>(0.00 - 10.00)   | 514  |
| n8-66 (0235) Expert | V Limit Output Filter                   | <input type="checkbox"/> V/f <input type="checkbox"/> CL-V/f <input type="checkbox"/> OLV <input type="checkbox"/> CLV <input type="checkbox"/> AOLV <input checked="" type="checkbox"/> OLV/PM <input checked="" type="checkbox"/> AOLV/PM <input type="checkbox"/> CLV/PM <input type="checkbox"/> EZOLV<br>Sets the filter time constant for output voltage control. Usually it is not necessary to change this setting.   | 0.020 s<br>(0.000 - 5.000)   | 515  |
| n8-69 (065D) Expert | Speed Observer Control P Gain           | <input type="checkbox"/> V/f <input type="checkbox"/> CL-V/f <input type="checkbox"/> OLV <input type="checkbox"/> CLV <input type="checkbox"/> AOLV <input type="checkbox"/> OLV/PM <input checked="" type="checkbox"/> AOLV/PM <input type="checkbox"/> CLV/PM <input type="checkbox"/> EZOLV<br>Sets the gain that the drive uses for speed estimation. Usually it is not necessary to change this setting.  | 1.00<br>(0.00 - 20.00)   | 515  |
| n8-70 (065E) Expert | Speed Estimation Integral Time Constant | <input type="checkbox"/> V/f <input type="checkbox"/> CL-V/f <input type="checkbox"/> OLV <input type="checkbox"/> CLV <input type="checkbox"/> AOLV <input type="checkbox"/> OLV/PM <input checked="" type="checkbox"/> AOLV/PM <input type="checkbox"/> CLV/PM <input type="checkbox"/> EZOLV<br>Sets the speed estimator integral time constant. It is available when <i>n8-72</i> = 1 [Initial Pole Detection Method = Method 2]. Usually it is not necessary to change this setting.                           | 0.0 s<br>(0.0 - 100.0)   | 515  |
| n8-71 (065F) Expert | Speed Estimation Differential Gain      | <input type="checkbox"/> V/f <input type="checkbox"/> CL-V/f <input type="checkbox"/> OLV <input type="checkbox"/> CLV <input type="checkbox"/> AOLV <input type="checkbox"/> OLV/PM <input checked="" type="checkbox"/> AOLV/PM <input type="checkbox"/> CLV/PM <input type="checkbox"/> EZOLV<br>Set the speed estimator differential gain. It is available when <i>n8-72</i> = 1 [Initial Pole Detection Method = Method 2]. Usually it is not necessary to change this setting.                                 | 5.00<br>(0.00 - 50.00)   | 515  |
| n8-72 (0655) Expert | Speed Estimation Method Select          | <input type="checkbox"/> V/f <input type="checkbox"/> CL-V/f <input type="checkbox"/> OLV <input type="checkbox"/> CLV <input type="checkbox"/> AOLV <input type="checkbox"/> OLV/PM <input checked="" type="checkbox"/> AOLV/PM <input type="checkbox"/> CLV/PM <input type="checkbox"/> EZOLV<br>Selects the speed estimation method. Usually it is not necessary to change this setting.<br>0 : Method 1<br>1 : Method 2   | 1<br>(0, 1)  | 515  |
| n8-73 (0656) Expert | Pull-in Current Reduction Level         | <input type="checkbox"/> V/f <input type="checkbox"/> CL-V/f <input type="checkbox"/> OLV <input type="checkbox"/> CLV <input type="checkbox"/> AOLV <input type="checkbox"/> OLV/PM <input checked="" type="checkbox"/> AOLV/PM <input type="checkbox"/> CLV/PM <input type="checkbox"/> EZOLV<br>Sets the speed level for pull-in current control at motor start as a percentage of <i>E1-06</i> [Base Frequency]. Usually it is not necessary to change this setting.  | 10%<br>(0 - 100)   | 515  |
| n8-74 (05C3)        | Light Load Iq Level                     | <input type="checkbox"/> V/f <input type="checkbox"/> CL-V/f <input type="checkbox"/> OLV <input type="checkbox"/> CLV <input type="checkbox"/> AOLV <input checked="" type="checkbox"/> OLV/PM <input type="checkbox"/> AOLV/PM <input type="checkbox"/> CLV/PM <input type="checkbox"/> EZOLV<br>Set <i>n8-48</i> [Pull-in/Light Load Id Current] to the level of the load current (q-axis current) to be applied.  | 30%<br>(0 - 255%)  | 515  |
| n8-75 (05C4)        | Medium Load Iq Level (low)              | <input type="checkbox"/> V/f <input type="checkbox"/> CL-V/f <input type="checkbox"/> OLV <input type="checkbox"/> CLV <input type="checkbox"/> AOLV <input checked="" type="checkbox"/> OLV/PM <input type="checkbox"/> AOLV/PM <input type="checkbox"/> CLV/PM <input type="checkbox"/> EZOLV<br>Set <i>n8-78</i> [Medium Load Id Current] to the level of the load current (q-axis current) to be applied.   | 50%<br>(0 - 255%)  | 516  |
| n8-76 (05CD) Expert | d-axis I Switching Time Constant        | <input type="checkbox"/> V/f <input type="checkbox"/> CL-V/f <input type="checkbox"/> OLV <input type="checkbox"/> CLV <input type="checkbox"/> AOLV <input checked="" type="checkbox"/> OLV/PM <input type="checkbox"/> AOLV/PM <input type="checkbox"/> CLV/PM <input type="checkbox"/> EZOLV<br>Sets the filter time constant for d-axis current reference. Usually it is not necessary to change this setting.  | 200 ms<br>(0 - 5000)   | 516  |
| n8-77 (05CE)        | Heavy Load Iq Level                     | <input type="checkbox"/> V/f <input type="checkbox"/> CL-V/f <input type="checkbox"/> OLV <input type="checkbox"/> CLV <input type="checkbox"/> AOLV <input checked="" type="checkbox"/> OLV/PM <input type="checkbox"/> AOLV/PM <input type="checkbox"/> CLV/PM <input type="checkbox"/> EZOLV<br>Set <i>n8-49</i> [Heavy Load Id Current] to the level of the load current (q-axis current) to be applied.  | 90%<br>(0 - 255%)  | 516  |
| n8-78 (05F4)        | Medium Load Id Current                  | <input type="checkbox"/> V/f <input type="checkbox"/> CL-V/f <input type="checkbox"/> OLV <input type="checkbox"/> CLV <input type="checkbox"/> AOLV <input checked="" type="checkbox"/> OLV/PM <input type="checkbox"/> AOLV/PM <input type="checkbox"/> CLV/PM <input type="checkbox"/> EZOLV<br>Sets the level of the pull-in current for mid-range loads.   | 0%<br>(-200 - +200%)   | 516  |

| No. (Hex.)                | Name                            | Description  | Default (Range)               | Ref. |
|---------------------------|---------------------------------|--|-------------------------------|------|
| n8-79<br>(05FE)           | Pull-in Current @ Deceleration  | <p>V/f CL-V/f OLV CLV AOLV <b>OLV/PM</b> AOLV/PM CLV/PM EZOLV</p> <p>Sets the pull-in current allowed to flow during deceleration as a percentage of the E5-03 [PM Motor Rated Current (FLA)].</p> <p><b>Note:</b><br/>When n8-79 = 0, the drive will use the value set in n8-51 [Pull-in Current @ Acceleration].</p> | 50%<br>(0 - 200%)             | 516  |
| n8-84<br>(02D3)<br>Expert | Polarity Detection Current      | <p>V/f CL-V/f OLV CLV AOLV <b>OLV/PM</b> AOLV/PM CLV/PM EZOLV</p> <p>Sets, as a percentage, the current for processing an estimation of the initial motor magnetic pole, assuming that the E5-03 [PM Motor Rated Current] is the 100% value.</p>   | 100%<br>(0 - 150%)            | 516  |
| n8-94<br>(012D)<br>Expert | Flux Position Estimation Method | <p>V/f CL-V/f OLV CLV AOLV <b>OLV/PM</b> AOLV/PM CLV/PM EZOLV</p> <p>Sets the criteria that the drive uses to find changes in speed or load. Usually it is not necessary to change this setting.</p> <p>0 : Softstarter<br/>1 : Speed Feedback</p>   | Determined by d5-01<br>(0, 1) | 517  |
| n8-95<br>(012E)<br>Expert | Flux Position Est Filter Time   | <p>V/f CL-V/f OLV CLV AOLV <b>OLV/PM</b> AOLV/PM CLV/PM EZOLV</p> <p>Sets the time constant of the filter used for the recognition criteria value for speed and load changes. Usually it is not necessary to change this setting.</p>  | 30 ms<br>(0 - 100 ms)         | 517  |

## 1.13 o: Keypad-Related Settings

### ◆ o1: Keypad Display

| No. (Hex.)                              | Name                             | Description  | Default (Range)   | Ref. |
|---|----------------------------------|--|---|------|
| o1-01<br>(0500)<br>RUN                  | User Monitor Selection           | <p><b>V/f</b> <b>CL-V/f</b> <b>OLV</b> <b>CLV</b> <b>AOLV</b> <b>OLV/PM</b> <b>AOLV/PM</b> <b>CLV/PM</b> <b>EZOLV</b></p> <p>Sets the <i>U</i> monitor for the Drive Mode. This parameter is only available when you use an LED keypad.</p> <p><b>Note:</b><br/>You cannot select <i>U2</i> monitor [Fault Trace] or <i>U3</i> Monitor [Fault History].</p>  | 106<br>(104 - 855)  | 519  |
| o1-02<br>(0501)<br>RUN                  | Monitor Selection at Power-up    | <p><b>V/f</b> <b>CL-V/f</b> <b>OLV</b> <b>CLV</b> <b>AOLV</b> <b>OLV/PM</b> <b>AOLV/PM</b> <b>CLV/PM</b> <b>EZOLV</b></p> <p>Sets the monitor item that the keypad screen shows after energizing the drive. Refer to "U: Monitors" for information about the monitor items that the keypad screen can show. This parameter is only available when you use an LED keypad.</p> <p>1 : Frequency Reference (U1-01)<br/>2 : Direction<br/>3 : Output Frequency (U1-02)<br/>4 : Output Current (U1-03)<br/>5 : User Monitor (o1-01)</p> | 1<br>(1 - 5)  | 519  |
| o1-03<br>(0502)                         | Frequency Display Unit Selection | <p><b>V/f</b> <b>CL-V/f</b> <b>OLV</b> <b>CLV</b> <b>AOLV</b> <b>OLV/PM</b> <b>AOLV/PM</b> <b>CLV/PM</b> <b>EZOLV</b></p> <p>Sets the display units for the frequency reference and output frequency.</p> <p>0 : 0.01Hz units<br/>1 : 0.01% units<br/>2 : min<sup>-1</sup> (r/min) unit<br/>3 : User Units</p>   | Determined by A1-02<br>(0 - 3)  | 519  |
| o1-04<br>(0503)                         | V/f Pattern Display Unit         | <p><b>V/f</b> <b>CL-V/f</b> <b>OLV</b> <b>CLV</b> <b>AOLV</b> <b>OLV/PM</b> <b>AOLV/PM</b> <b>CLV/PM</b> <b>EZOLV</b></p> <p>Sets the setting unit for parameters that set the V/f pattern frequency.</p> <p>0 : Hz<br/>1 : min<sup>-1</sup> (r/min) unit</p>  | Determined by A1-02<br>(0, 1)   | 520  |
| o1-05<br>(0504)<br>RUN                  | LCD Contrast Adjustment          | <p><b>V/f</b> <b>CL-V/f</b> <b>OLV</b> <b>CLV</b> <b>AOLV</b> <b>OLV/PM</b> <b>AOLV/PM</b> <b>CLV/PM</b> <b>EZOLV</b></p> <p>Sets the contrast of the LCD display on the keypad.</p>   | 5<br>(0 - 10)   | 521  |
| o1-10<br>(0520)                         | User Units Maximum Value         | <p><b>V/f</b> <b>CL-V/f</b> <b>OLV</b> <b>CLV</b> <b>AOLV</b> <b>OLV/PM</b> <b>AOLV/PM</b> <b>CLV/PM</b> <b>EZOLV</b></p> <p>Sets the value that the drive shows as the maximum output frequency.</p>  | Determined by o1-03<br>(1 - 60000)  | 521  |
| o1-11<br>(0521)                         | User Units Decimal Position      | <p><b>V/f</b> <b>CL-V/f</b> <b>OLV</b> <b>CLV</b> <b>AOLV</b> <b>OLV/PM</b> <b>AOLV/PM</b> <b>CLV/PM</b> <b>EZOLV</b></p> <p>Sets the number of decimal places for frequency reference and monitor values.</p> <p>0 : No Decimal Places (XXXXXX)<br/>1 : One Decimal Places (XXXX.X)<br/>2 : Two Decimal Places (XXX.XX)<br/>3 : Three Decimal Places (XX.XXX)</p>   | Determined by o1-03<br>(0 - 3)  | 521  |
| o1-24 to o1-35:<br>(11AD - 11B8)<br>RUN | Custom Monitor 1 to 12           | <p><b>V/f</b> <b>CL-V/f</b> <b>OLV</b> <b>CLV</b> <b>AOLV</b> <b>OLV/PM</b> <b>AOLV/PM</b> <b>CLV/PM</b> <b>EZOLV</b></p> <p>Sets a maximum of 12 monitors as user monitors. This parameter is only available when using an LCD keypad.</p>  | o1-24: 101<br>o1-25: 102<br>o1-26: 103<br>o1-27 to o1-35: 0<br>(0, 101 - 999) | 521  |
| o1-36<br>(11B9)<br>RUN                  | LCD Backlight Brightness         | <p><b>V/f</b> <b>CL-V/f</b> <b>OLV</b> <b>CLV</b> <b>AOLV</b> <b>OLV/PM</b> <b>AOLV/PM</b> <b>CLV/PM</b> <b>EZOLV</b></p> <p>Sets the intensity of the LCD keypad backlight.</p>   | 5<br>(1 - 5)  | 522  |
| o1-37<br>(11BA)<br>RUN                  | LCD Backlight ON/OFF Selection   | <p><b>V/f</b> <b>CL-V/f</b> <b>OLV</b> <b>CLV</b> <b>AOLV</b> <b>OLV/PM</b> <b>AOLV/PM</b> <b>CLV/PM</b> <b>EZOLV</b></p> <p>Sets the automatic shut off function for the LCD backlight.</p> <p>0 : OFF<br/>1 : ON</p>   | 0<br>(0, 1)   | 522  |
| o1-38<br>(11BB)<br>RUN                  | LCD Backlight Off-Delay          | <p><b>V/f</b> <b>CL-V/f</b> <b>OLV</b> <b>CLV</b> <b>AOLV</b> <b>OLV/PM</b> <b>AOLV/PM</b> <b>CLV/PM</b> <b>EZOLV</b></p> <p>Sets the time until the LCD backlight automatically turns off.</p>  | 60 s<br>(10 - 300 s)  | 523  |
| o1-39<br>(11BC)<br>RUN                  | Show Initial Setup Screen        | <p><b>V/f</b> <b>CL-V/f</b> <b>OLV</b> <b>CLV</b> <b>AOLV</b> <b>OLV/PM</b> <b>AOLV/PM</b> <b>CLV/PM</b> <b>EZOLV</b></p> <p>Sets the function to show the LCD keypad initial setup screen each time the drive is energized. This parameter is only available when using an LCD keypad.</p> <p>0 : No<br/>1 : Yes</p>  | 1<br>(0, 1)   | 523  |





## 1.13 o: Keypad-Related Settings

| No. (Hex.)             | Name                             | Description   | Default (Range)               | Ref. |
|------------------------|----------------------------------|---|-------------------------------|------|
| o1-40<br>(11BD)<br>RUN | Home Screen Display Selection    | <b>V/f</b> <b>CL-V/f</b> <b>OLV</b> <b>CLV</b> <b>AOLV</b> <b>OLV/PM</b> <b>AOLV/PM</b> <b>CLV/PM</b> <b>EZOLV</b><br>Sets the monitor display mode for the Home screen. This parameter is only available when using an LCD keypad.<br>0 : Custom Monitor<br>1 : Bar Graph<br>2 : Analog Gauge<br>3 : Trend Plot  | 0<br>(0 - 3)                  | 523  |
| o1-41<br>(11C1)<br>RUN | 1st Monitor Area Selection       | <b>V/f</b> <b>CL-V/f</b> <b>OLV</b> <b>CLV</b> <b>AOLV</b> <b>OLV/PM</b> <b>AOLV/PM</b> <b>CLV/PM</b> <b>EZOLV</b><br>Sets the horizontal range used to display the monitor set in o1-24 [Custom Monitor 1] as a bar graph. This parameter is only available when using an LCD keypad.<br>0 : +/- Area ( - o1-42 ~ o1-42 )<br>1 : + Area ( 0 ~ o1-42 )<br>2 : - Area ( - o1-42 ~ 0 )    | 0<br>(0 - 2)                  | 523  |
| o1-42<br>(11C2)<br>RUN | 1st Monitor Area Setting         | <b>V/f</b> <b>CL-V/f</b> <b>OLV</b> <b>CLV</b> <b>AOLV</b> <b>OLV/PM</b> <b>AOLV/PM</b> <b>CLV/PM</b> <b>EZOLV</b><br>Sets the horizontal axis value used to display the monitor set in o1-24 [Custom Monitor 1] as a bar graph. This parameter is only available when using an LCD keypad.   | 100.0%<br>(0.0 - 100.0%)      | 524  |
| o1-43<br>(11C3)<br>RUN | 2nd Monitor Area Selection       | <b>V/f</b> <b>CL-V/f</b> <b>OLV</b> <b>CLV</b> <b>AOLV</b> <b>OLV/PM</b> <b>AOLV/PM</b> <b>CLV/PM</b> <b>EZOLV</b><br>Selects the horizontal range used to display the monitor set in o1-25 [Custom Monitor 2] as a bar graph. This parameter is only available when using an LCD keypad.<br>0 : +/- Area ( - o1-44 ~ o1-44 )<br>1 : + Area ( 0 ~ o1-44 )<br>2 : - Area ( - o1-44 ~ 0 ) | 0<br>(0 - 2)                  | 524  |
| o1-44<br>(11C4)<br>RUN | 2nd Monitor Area Setting         | <b>V/f</b> <b>CL-V/f</b> <b>OLV</b> <b>CLV</b> <b>AOLV</b> <b>OLV/PM</b> <b>AOLV/PM</b> <b>CLV/PM</b> <b>EZOLV</b><br>Sets the horizontal axis value used to display the monitor set in o1-25 [Custom Monitor 2] as a bar graph. This parameter is only available when using an LCD keypad.   | 100.0%<br>(0.0 - 100.0%)      | 524  |
| o1-45<br>(11C5)<br>RUN | 3rd Monitor Area Selection       | <b>V/f</b> <b>CL-V/f</b> <b>OLV</b> <b>CLV</b> <b>AOLV</b> <b>OLV/PM</b> <b>AOLV/PM</b> <b>CLV/PM</b> <b>EZOLV</b><br>Sets the horizontal range used to display the monitor set in o1-26 [Custom Monitor 3] as a bar graph. This parameter is only available when using an LCD keypad.<br>0 : +/- Area ( - o1-46 ~ o1-46 )<br>1 : + Area ( 0 ~ o1-46 )<br>2 : - Area ( - o1-46 ~ 0 )    | 0<br>(0 - 2)                  | 524  |
| o1-46<br>(11C6)<br>RUN | 3rd Monitor Area Setting         | <b>V/f</b> <b>CL-V/f</b> <b>OLV</b> <b>CLV</b> <b>AOLV</b> <b>OLV/PM</b> <b>AOLV/PM</b> <b>CLV/PM</b> <b>EZOLV</b><br>Sets the horizontal axis value used to display the monitor set in o1-26 [Custom Monitor 3] as a bar graph. This parameter is only available when using an LCD keypad.   | 100.0%<br>(0.0 - 100.0%)      | 524  |
| o1-47<br>(11C7)<br>RUN | Trend Plot 1 Scale Minimum Value | <b>V/f</b> <b>CL-V/f</b> <b>OLV</b> <b>CLV</b> <b>AOLV</b> <b>OLV/PM</b> <b>AOLV/PM</b> <b>CLV/PM</b> <b>EZOLV</b><br>Sets the horizontal axis minimum value used to display the monitor set in o1-24 [Custom Monitor 1] as a trend plot. This parameter is only available when using an LCD keypad.  | -100.0%<br>(-300.0 - +300.0%) | 524  |
| o1-48<br>(11C8)<br>RUN | Trend Plot 1 Scale Maximum Value | <b>V/f</b> <b>CL-V/f</b> <b>OLV</b> <b>CLV</b> <b>AOLV</b> <b>OLV/PM</b> <b>AOLV/PM</b> <b>CLV/PM</b> <b>EZOLV</b><br>Sets the horizontal axis maximum value used to display the monitor set in o1-24 [Custom Monitor 1] as a trend plot. This parameter is only available when using an LCD keypad.  | 100.0%<br>(-300.0 - +300.0%)  | 525  |
| o1-49<br>(11C9)<br>RUN | Trend Plot 2 Scale Minimum Value | <b>V/f</b> <b>CL-V/f</b> <b>OLV</b> <b>CLV</b> <b>AOLV</b> <b>OLV/PM</b> <b>AOLV/PM</b> <b>CLV/PM</b> <b>EZOLV</b><br>Sets the horizontal axis minimum value used to display the monitor set in o1-25 [Custom Monitor 2] as a trend plot. This parameter is only available when using an LCD keypad.  | -100.0%<br>(-300.0 - +300.0%) | 525  |
| o1-50<br>(11CA)<br>RUN | Trend Plot 2 Scale Maximum Value | <b>V/f</b> <b>CL-V/f</b> <b>OLV</b> <b>CLV</b> <b>AOLV</b> <b>OLV/PM</b> <b>AOLV/PM</b> <b>CLV/PM</b> <b>EZOLV</b><br>Sets the horizontal axis maximum value used to display the monitor set in o1-25 [Custom Monitor 2] as a trend plot. This parameter is only available when using an LCD keypad.  | 100.0%<br>(-300.0 - +300.0%)  | 525  |
| o1-51<br>(11CB)<br>RUN | Trend Plot Time Scale Setting    | <b>V/f</b> <b>CL-V/f</b> <b>OLV</b> <b>CLV</b> <b>AOLV</b> <b>OLV/PM</b> <b>AOLV/PM</b> <b>CLV/PM</b> <b>EZOLV</b><br>Sets the time scale (horizontal axis) to display the trend plot. When you change this setting, the drive automatically adjusts the data sampling time. This parameter is only available when using an LCD keypad.   | 300 s<br>(1 - 3600 s)         | 525  |
| o1-55<br>(11EE)<br>RUN | Analog Gauge Area Selection      | <b>V/f</b> <b>CL-V/f</b> <b>OLV</b> <b>CLV</b> <b>AOLV</b> <b>OLV/PM</b> <b>AOLV/PM</b> <b>CLV/PM</b> <b>EZOLV</b><br>Sets the range used to display the monitor set in o1-24 [Custom Monitor 1] as an analog gauge. This parameter is only available when using an LCD keypad.<br>0 : +/- Area ( - o1-56 ~ o1-56 )<br>1 : + Area ( 0 ~ o1-56 )   | 1<br>(0, 1)                   | 525  |

## 1.13 o: Keypad-Related Settings

| No. (Hex.)       | Name                       | Description   | Default (Range)          | Ref. |
|------------------|----------------------------|---|--------------------------|------|
| o1-56 (11EF) RUN | Analog Gauge Area Setting  | <b>V/f</b> <b>CL-V/f</b> <b>OLV</b> <b>CLV</b> <b>AOLV</b> <b>OLV/PM</b> <b>AOLV/PM</b> <b>CLV/PM</b> <b>EZOLV</b><br>Sets the value used to display the monitor set in o1-24 [Custom Monitor 1] as an analog meter. This parameter is only available when using an LCD keypad. | 100.0%<br>(0.0 - 100.0%) | 525  |
| o1-58 (3125)     | Motor Power Unit Selection | <b>V/f</b> <b>CL-V/f</b> <b>OLV</b> <b>CLV</b> <b>AOLV</b> <b>OLV/PM</b> <b>AOLV/PM</b> <b>CLV/PM</b> <b>EZOLV</b><br>Sets the setting unit for parameters that set the motor rated power.<br>0 : kW<br>1 : HP  | 1<br>(0, 1)              | 525  |

## ◆ o2: Keypad Operation

| No. (Hex.)       | Name                             | Description   | Default (Range)                | Ref. |
|------------------|----------------------------------|---|--------------------------------|------|
| o2-01 (0505)     | LO/RE Key Function Selection     | <b>V/f</b> <b>CL-V/f</b> <b>OLV</b> <b>CLV</b> <b>AOLV</b> <b>OLV/PM</b> <b>AOLV/PM</b> <b>CLV/PM</b> <b>EZOLV</b><br>Sets the function that lets the drive switch between LOCAL and REMOTE Modes using <b>LO/RE</b> .<br>0 : Disabled<br>1 : Enabled   | 1<br>(0, 1)                    | 526  |
| o2-02 (0506)     | STOP Key Function Selection      | <b>V/f</b> <b>CL-V/f</b> <b>OLV</b> <b>CLV</b> <b>AOLV</b> <b>OLV/PM</b> <b>AOLV/PM</b> <b>CLV/PM</b> <b>EZOLV</b><br>Sets the function to stop the drive with the  button on the keypad when the Run command source for the drive is REMOTE (external) and not assigned to the keypad.<br>0 : Disabled<br>1 : Enabled | 1<br>(0, 1)                    | 526  |
| o2-03 (0507)     | User Parameter Default Value     | <b>V/f</b> <b>CL-V/f</b> <b>OLV</b> <b>CLV</b> <b>AOLV</b> <b>OLV/PM</b> <b>AOLV/PM</b> <b>CLV/PM</b> <b>EZOLV</b><br>Sets the function to keep the settings of changed parameters as user parameter defaults to use during initialization.<br>0 : No change<br>1 : Set defaults<br>2 : Clear all   | 0<br>(0 - 2)                   | 527  |
| o2-04 (0508)     | Drive Model (KVA) Selection      | <b>V/f</b> <b>CL-V/f</b> <b>OLV</b> <b>CLV</b> <b>AOLV</b> <b>OLV/PM</b> <b>AOLV/PM</b> <b>CLV/PM</b> <b>EZOLV</b><br>Sets the Drive Model code. Set this parameter after replacing the control board.  | Determined by the drive<br>(-) | 527  |
| o2-05 (0509)     | Home Mode Freq Ref Entry Mode    | <b>V/f</b> <b>CL-V/f</b> <b>OLV</b> <b>CLV</b> <b>AOLV</b> <b>OLV/PM</b> <b>AOLV/PM</b> <b>CLV/PM</b> <b>EZOLV</b><br>Sets the function that makes it necessary to push the  to change the frequency reference value with the keypad when in Drive Mode.<br>0 : ENTER Key Required<br>1 : Immediate / MOP-style      | 0<br>(0, 1)                    | 528  |
| o2-06 (050A)     | Keypad Disconnect Detection      | <b>V/f</b> <b>CL-V/f</b> <b>OLV</b> <b>CLV</b> <b>AOLV</b> <b>OLV/PM</b> <b>AOLV/PM</b> <b>CLV/PM</b> <b>EZOLV</b><br>Sets the function that stops the drive if you disconnect the keypad connection cable from the drive or if you damage the cable while the keypad is the Run command source.<br>0 : Disabled<br>1 : Enabled   | 1<br>(0, 1)                    | 528  |
| o2-07 (0527)     | Keypad RUN Direction @ Power-up  | <b>V/f</b> <b>CL-V/f</b> <b>OLV</b> <b>CLV</b> <b>AOLV</b> <b>OLV/PM</b> <b>AOLV/PM</b> <b>CLV/PM</b> <b>EZOLV</b><br>Sets the direction of motor rotation when the drive is energized and the keypad is the Run command source.<br>0 : Forward run<br>1 : Reverse run  | 0<br>(0, 1)                    | 529  |
| o2-09 (050D)     | Region Code                      | -   | -                              | 529  |
| o2-23 (11F8) RUN | External 24V Powerloss Detection | <b>V/f</b> <b>CL-V/f</b> <b>OLV</b> <b>CLV</b> <b>AOLV</b> <b>OLV/PM</b> <b>AOLV/PM</b> <b>CLV/PM</b> <b>EZOLV</b><br>Sets the function to give a warning when the backup external 24 V power supply turns off when the main circuit power supply is in operation.<br>0 : Disabled<br>1 : Yes   | 0<br>(0, 1)                    | 529  |
| o2-24 (11FE)     | LED Light Function Selection     | <b>V/f</b> <b>CL-V/f</b> <b>OLV</b> <b>CLV</b> <b>AOLV</b> <b>OLV/PM</b> <b>AOLV/PM</b> <b>CLV/PM</b> <b>EZOLV</b><br>Sets the function to show the LED status rings and keypad LED lamps.<br>0 : Enable Status Ring & Keypad LED<br>1 : LED Status Ring Disable<br>2 : Keypad LED Light Disable  | 2<br>(0 - 2)                   | 529  |

| No. (Hex.)   | Name                            | Description  | Default (Range) | Ref. |
|--------------|---------------------------------|--|-----------------|------|
| o2-26 (1563) | Alarm display at ext. 24V power | <p><b>V/f</b> <b>CL-V/f</b> <b>OLV</b> <b>CLV</b> <b>AOLV</b> <b>OLV/PM</b> <b>AOLV/PM</b> <b>CLV/PM</b> <b>EZOLV</b></p> <p>When you connect a backup external 24 V power supply, this parameter sets the function to trigger an alarm when the main circuit power supply voltage decreases.</p> <p><b>Note:</b><br/>The drive will not run when it is operating from one 24-V external power supply.</p> <p>0 : No<br/>1 : Yes</p> | 1<br>(0, 1)     | 529  |
| o2-27 (1565) | bCE Detection Selection         | <p><b>V/f</b> <b>CL-V/f</b> <b>OLV</b> <b>CLV</b> <b>AOLV</b> <b>OLV/PM</b> <b>AOLV/PM</b> <b>CLV/PM</b> <b>EZOLV</b></p> <p>Sets drive operation if the Bluetooth device is disconnected when you operate the drive in Bluetooth Mode.</p> <p>0 : Ramp to Stop<br/>1 : Coast to Stop<br/>2 : Fast Stop (Use <i>CI-09</i>)<br/>3 : Alarm Only<br/>4 : No Alarm Display</p>   | 3<br>(0 - 4)    | 530  |

### ◆ o3: Copy Keypad Function

| No. (Hex.)   | Name                            | Description  | Default (Range) | Ref. |
|--------------|---------------------------------|--|-----------------|------|
| o3-01 (0515) | Copy Keypad Function Selection  | <p><b>V/f</b> <b>CL-V/f</b> <b>OLV</b> <b>CLV</b> <b>AOLV</b> <b>OLV/PM</b> <b>AOLV/PM</b> <b>CLV/PM</b> <b>EZOLV</b></p> <p>Sets the function that saves and copies drive parameters to a different drive with the keypad.</p> <p>0 : Copy Select<br/>1 : Backup (drive → keypad)<br/>2 : Restore (keypad → drive)<br/>3 : Verify (check for mismatch)<br/>4 : Erase (backup data of keypad)</p>  | 0<br>(0 - 4)    | 530  |
| o3-02 (0516) | Copy Allowed Selection          | <p><b>V/f</b> <b>CL-V/f</b> <b>OLV</b> <b>CLV</b> <b>AOLV</b> <b>OLV/PM</b> <b>AOLV/PM</b> <b>CLV/PM</b> <b>EZOLV</b></p> <p>Sets the copy function when <i>o3-01 = 1</i> [<i>Copy Keypad Function Selection = Backup (drive → keypad)</i>].</p> <p>0 : Disabled<br/>1 : Enabled</p>   | 0<br>(0, 1)     | 530  |
| o3-04 (0B3E) | Select Backup/Restore Location  | <p><b>V/f</b> <b>CL-V/f</b> <b>OLV</b> <b>CLV</b> <b>AOLV</b> <b>OLV/PM</b> <b>AOLV/PM</b> <b>CLV/PM</b> <b>EZOLV</b></p> <p>Sets the storage location for drive parameters when you back up and restore parameters. This parameter is only available when using an LCD keypad.</p> <p>0 : Memory Location 1<br/>1 : Memory Location 2<br/>2 : Memory Location 3<br/>3 : Memory Location 4</p>   | 0<br>(0 - 3)    | 531  |
| o3-05 (0BDA) | Select Items to Backup/Restore  | <p><b>V/f</b> <b>CL-V/f</b> <b>OLV</b> <b>CLV</b> <b>AOLV</b> <b>OLV/PM</b> <b>AOLV/PM</b> <b>CLV/PM</b> <b>EZOLV</b></p> <p>Sets which parameters are backed up, restored, and referenced. This parameter is only available when using an LCD keypad.</p> <p>0 : Standard Parameters<br/>1 : Standard + DWEZ Parameters</p>   | 1<br>(0, 1)     | 531  |
| o3-06 (0BDE) | Auto Parameter Backup Selection | <p><b>V/f</b> <b>CL-V/f</b> <b>OLV</b> <b>CLV</b> <b>AOLV</b> <b>OLV/PM</b> <b>AOLV/PM</b> <b>CLV/PM</b> <b>EZOLV</b></p> <p>Sets the function that automatically backs up parameters. This parameter is only available when using an LCD keypad.</p> <p>0 : Disabled<br/>1 : Enabled</p>  | 1<br>(0, 1)     | 531  |
| o3-07 (0BDF) | Auto Parameter Backup Interval  | <p><b>V/f</b> <b>CL-V/f</b> <b>OLV</b> <b>CLV</b> <b>AOLV</b> <b>OLV/PM</b> <b>AOLV/PM</b> <b>CLV/PM</b> <b>EZOLV</b></p> <p>Sets the interval at which the automatic parameter backup function saves parameters from the drive to the keypad.</p> <p><b>Note:</b><br/>This parameter is only available when using an LCD keypad.</p> <p>0 : Every 10 minutes<br/>1 : Every 30 minutes<br/>2 : Every 60 minutes<br/>3 : Every 12 hours</p> | 1<br>(0 - 3)    | 531  |

## 1.13 o: Keypad-Related Settings

### ◆ o4: Maintenance Monitors

| No. (Hex.)       | Name                             | Description   | Default (Range)     | Ref. |
|------------------|----------------------------------|---|---------------------|------|
| o4-01 (050B)     | Elapsed Operating Time Setting   | <b>V/f</b> <b>CL-V/f</b> <b>OLV</b> <b>CLV</b> <b>AOLV</b> <b>OLV/PM</b> <b>AOLV/PM</b> <b>CLV/PM</b> <b>EZOLV</b><br>Sets the initial value of the cumulative drive operation time in 10-hour units.   | 0 h<br>(0 - 9999 h) | 532  |
| o4-02 (050C)     | Elapsed Operating Time Selection | <b>V/f</b> <b>CL-V/f</b> <b>OLV</b> <b>CLV</b> <b>AOLV</b> <b>OLV/PM</b> <b>AOLV/PM</b> <b>CLV/PM</b> <b>EZOLV</b><br>Sets the condition that counts the cumulative operation time.<br>0 : U4-01 Shows Total Power-up Time<br>1 : U4-01 Shows Total RUN Time  | 0<br>(0, 1)         | 532  |
| o4-03 (050E)     | Fan Operation Time Setting       | <b>V/f</b> <b>CL-V/f</b> <b>OLV</b> <b>CLV</b> <b>AOLV</b> <b>OLV/PM</b> <b>AOLV/PM</b> <b>CLV/PM</b> <b>EZOLV</b><br>Sets the value from which to start the cumulative drive cooling fan operation time in 10-hour units.  | 0 h<br>(0 - 9999 h) | 532  |
| o4-05 (051D)     | Capacitor Maintenance Setting    | <b>V/f</b> <b>CL-V/f</b> <b>OLV</b> <b>CLV</b> <b>AOLV</b> <b>OLV/PM</b> <b>AOLV/PM</b> <b>CLV/PM</b> <b>EZOLV</b><br>Sets the U4-05 [CapacitorMaintenance] monitor value.  | 0%<br>(0 - 150%)    | 532  |
| o4-07 (0523)     | Softcharge Relay Maintenance Set | <b>V/f</b> <b>CL-V/f</b> <b>OLV</b> <b>CLV</b> <b>AOLV</b> <b>OLV/PM</b> <b>AOLV/PM</b> <b>CLV/PM</b> <b>EZOLV</b><br>Sets the U4-06 [PreChargeRelayMainte] monitor value.  | 0%<br>(0 - 150%)    | 533  |
| o4-09 (0525)     | IGBT Maintenance Setting         | <b>V/f</b> <b>CL-V/f</b> <b>OLV</b> <b>CLV</b> <b>AOLV</b> <b>OLV/PM</b> <b>AOLV/PM</b> <b>CLV/PM</b> <b>EZOLV</b><br>Sets the U4-07 [IGBT Maintenance] monitor value.  | 0%<br>(0 - 150%)    | 533  |
| o4-11 (0510)     | Fault Trace/History Init (U2/U3) | <b>V/f</b> <b>CL-V/f</b> <b>OLV</b> <b>CLV</b> <b>AOLV</b> <b>OLV/PM</b> <b>AOLV/PM</b> <b>CLV/PM</b> <b>EZOLV</b><br>Resets the records of Monitors U2-xx [Fault Trace] and U3-xx [Fault History].<br>0 : Disabled<br>1 : Enabled  | 0<br>(0, 1)         | 533  |
| o4-12 (0512)     | kWh Monitor Initialization       | <b>V/f</b> <b>CL-V/f</b> <b>OLV</b> <b>CLV</b> <b>AOLV</b> <b>OLV/PM</b> <b>AOLV/PM</b> <b>CLV/PM</b> <b>EZOLV</b><br>Resets the monitor values for U4-10 [kWh, Lower 4 Digits] and U4-11 [kWh, Upper 5 Digits].<br>0 : No Reset<br>1 : Reset   | 0<br>(0, 1)         | 533  |
| o4-13 (0528)     | RUN Command Counter @ Initialize | <b>V/f</b> <b>CL-V/f</b> <b>OLV</b> <b>CLV</b> <b>AOLV</b> <b>OLV/PM</b> <b>AOLV/PM</b> <b>CLV/PM</b> <b>EZOLV</b><br>Resets the monitor values for U4-02 [Num of Run Commands], U4-24 [Number of Runs (Low)], and U4-25 [Number of Runs (High)].<br>0 : No Reset<br>1 : Reset                      | 0<br>(0, 1)         | 534  |
| o4-22 (154F) RUN | Time Format                      | <b>V/f</b> <b>CL-V/f</b> <b>OLV</b> <b>CLV</b> <b>AOLV</b> <b>OLV/PM</b> <b>AOLV/PM</b> <b>CLV/PM</b> <b>EZOLV</b><br>Sets the time display format. This parameter is only available when using an LCD keypad.<br>0 : 24 Hour Clock<br>1 : 12 Hour Clock<br>2 : 12 Hour JP Clock                    | 1<br>(0 - 2)        | 534  |
| o4-23 (1550) RUN | Date Format                      | <b>V/f</b> <b>CL-V/f</b> <b>OLV</b> <b>CLV</b> <b>AOLV</b> <b>OLV/PM</b> <b>AOLV/PM</b> <b>CLV/PM</b> <b>EZOLV</b><br>Sets the date display format. This parameter is only available when using an LCD keypad.<br>0 : YYYY/MM/DD(2016/01/31)<br>1 : DD/MM/YYYY(31/01/2016)<br>2 : MM/DD/YYYY        | 2<br>(0 - 2)        | 534  |
| o4-24 (310F) RUN | bAT Detection Selection          | <b>V/f</b> <b>CL-V/f</b> <b>OLV</b> <b>CLV</b> <b>AOLV</b> <b>OLV/PM</b> <b>AOLV/PM</b> <b>CLV/PM</b> <b>EZOLV</b><br>Sets operation when the drive detects bAT [Keypad Battery Low Voltage] and TiM [Keypad Time Not Set].<br>0 : No<br>1 : Enable (Alarm Detected)<br>2 : Enable (Fault Detected) | 0<br>(0 - 2)        | 534  |

### ◆ o5: Log Function

| No. (Hex.)       | Name                     | Description   | Default (Range)            | Ref. |
|------------------|--------------------------|---|----------------------------|------|
| o5-01 (1551) RUN | Log Start/Stop Selection | <b>V/f</b> <b>CL-V/f</b> <b>OLV</b> <b>CLV</b> <b>AOLV</b> <b>OLV/PM</b> <b>AOLV/PM</b> <b>CLV/PM</b> <b>EZOLV</b><br>Sets the data log function. This parameter is only available when using an LCD keypad.<br>0 : OFF<br>1 : ON | 0<br>(0 - 1)               | 537  |
| o5-02 (1552) RUN | Log Sampling Interval    | <b>V/f</b> <b>CL-V/f</b> <b>OLV</b> <b>CLV</b> <b>AOLV</b> <b>OLV/PM</b> <b>AOLV/PM</b> <b>CLV/PM</b> <b>EZOLV</b><br>Sets the data log sampling cycle. This parameter is only available when using an LCD keypad.                | 100 ms<br>(100 - 60000 ms) | 537  |

## 1.13 o: Keypad-Related Settings

| No. (Hex.)             | Name                | Description   | Default (Range)  | Ref. |
|------------------------|---------------------|---|--|------|
| o5-03<br>(1553)<br>RUN | Log Monitor Data 1  | <b>V/f</b> <b>CL-V/f</b> <b>OLV</b> <b>CLV</b> <b>AOLV</b> <b>OLV/PM</b> <b>AOLV/PM</b> <b>CLV/PM</b> <b>EZOLV</b><br>Sets the data log monitor. This parameter is only available when using an LCD keypad. | 101<br>(000, 101 - 999)  | 538  |
| o5-04<br>(1554)<br>RUN | Log Monitor Data 2  | <b>V/f</b> <b>CL-V/f</b> <b>OLV</b> <b>CLV</b> <b>AOLV</b> <b>OLV/PM</b> <b>AOLV/PM</b> <b>CLV/PM</b> <b>EZOLV</b><br>Sets the data log monitor. This parameter is only available when using an LCD keypad. | 102<br>(000, 101 - 999)  | 538  |
| o5-05<br>(1555)<br>RUN | Log Monitor Data 3  | <b>V/f</b> <b>CL-V/f</b> <b>OLV</b> <b>CLV</b> <b>AOLV</b> <b>OLV/PM</b> <b>AOLV/PM</b> <b>CLV/PM</b> <b>EZOLV</b><br>Sets the data log monitor. This parameter is only available when using an LCD keypad. | 103<br>(000, 101 - 999)  | 538  |
| o5-06<br>(1556)<br>RUN | Log Monitor Data 4  | <b>V/f</b> <b>CL-V/f</b> <b>OLV</b> <b>CLV</b> <b>AOLV</b> <b>OLV/PM</b> <b>AOLV/PM</b> <b>CLV/PM</b> <b>EZOLV</b><br>Sets the data log monitor. This parameter is only available when using an LCD keypad. | 107<br>(000, 101 - 999)  | 538  |
| o5-07<br>(1557)<br>RUN | Log Monitor Data 5  | <b>V/f</b> <b>CL-V/f</b> <b>OLV</b> <b>CLV</b> <b>AOLV</b> <b>OLV/PM</b> <b>AOLV/PM</b> <b>CLV/PM</b> <b>EZOLV</b><br>Sets the data log monitor. This parameter is only available when using an LCD keypad. | 108<br>(000, 101 - 999)  | 538  |
| o5-08<br>(1558)<br>RUN | Log Monitor Data 6  | <b>V/f</b> <b>CL-V/f</b> <b>OLV</b> <b>CLV</b> <b>AOLV</b> <b>OLV/PM</b> <b>AOLV/PM</b> <b>CLV/PM</b> <b>EZOLV</b><br>Sets the data log monitor. This parameter is only available when using an LCD keypad. | V/f, OLV/PM: 0, CL-V/f,<br>OLV, CLV, AOLV,<br>AOLV/PM, CLV/PM,<br>EZOLV: 105<br>(000, 101 - 999) | 539  |
| o5-09<br>(1559)<br>RUN | Log Monitor Data 7  | <b>V/f</b> <b>CL-V/f</b> <b>OLV</b> <b>CLV</b> <b>AOLV</b> <b>OLV/PM</b> <b>AOLV/PM</b> <b>CLV/PM</b> <b>EZOLV</b><br>Sets the data log monitor. This parameter is only available when using an LCD keypad. | 110<br>(000, 101 - 999)  | 539  |
| o5-10<br>(155A)<br>RUN | Log Monitor Data 8  | <b>V/f</b> <b>CL-V/f</b> <b>OLV</b> <b>CLV</b> <b>AOLV</b> <b>OLV/PM</b> <b>AOLV/PM</b> <b>CLV/PM</b> <b>EZOLV</b><br>Sets the data log monitor. This parameter is only available when using an LCD keypad. | 112<br>(000, 101 - 999)  | 539  |
| o5-11<br>(155B)<br>RUN | Log Monitor Data 9  | <b>V/f</b> <b>CL-V/f</b> <b>OLV</b> <b>CLV</b> <b>AOLV</b> <b>OLV/PM</b> <b>AOLV/PM</b> <b>CLV/PM</b> <b>EZOLV</b><br>Sets the data log monitor. This parameter is only available when using an LCD keypad. | 000<br>(000, 101 - 999)  | 539  |
| o5-12<br>(155C)<br>RUN | Log Monitor Data 10 | <b>V/f</b> <b>CL-V/f</b> <b>OLV</b> <b>CLV</b> <b>AOLV</b> <b>OLV/PM</b> <b>AOLV/PM</b> <b>CLV/PM</b> <b>EZOLV</b><br>Sets the data log monitor. This parameter is only available when using an LCD keypad. | 000<br>(000, 101 - 999)  | 539  |

## 1.14 q: DriveWorksEZ Parameters

### ◆ q1-01 to q8-40: Reserved for DriveWorksEZ

| No.<br>(Hex.)                   | Name                      | Description   | Default<br>(Range)                                       |
|---------------------------------|---------------------------|---|--|
| q1-01 to q8-40<br>(1600 - 17E7) | Reserved for DriveWorksEZ | <span>V/f</span> <span>CL-V/f</span> <span>OLV</span> <span>CLV</span> <span>AOLV</span> <span>OLV/PM</span> <span>AOLV/PM</span> <span>CLV/PM</span> <span>EZOLV</span><br>Refer to "DriveWorksEZ Operation Manual". | These parameters are reserved for use with DriveWorksEZ. |

## 1.15 r: DWEZ Connection 1-20

### ◆ r1-01 to r1-40: DriveWorksEZ Connection Parameters 1 to 20 (Upper / Lower)

| No.<br>(Hex.)                    | Name   | Description  | Default<br>(Range) |
|----------------------------------|--|--|--------------------|
| r1-01 to r1-40:<br>(1840 - 1867) | DriveWorksEZ Connection<br>Parameters 1 to 20 (Upper /<br>Lower) | <div style="display: flex; justify-content: space-between; align-items: center;"> <span>V/f</span> <span>CL-V/f</span> <span>OLV</span> <span>CLV</span> <span>AOLV</span> <span>OLV/PM</span> <span>AOLV/PM</span> <span>CLV/PM</span> <span>EZOLV</span> </div> DriveWorksEZ Connection Parameters 1 to 20 (Upper / Lower) | 0<br>(0 - FFFFH)   |

## 1.16 T: Motor Tuning

### ◆ T0: Tuning Mode Selection

| No. (Hex.)   | Name                  | Description  | Default (Range) | Ref. |
|--------------|-----------------------|--|-----------------|------|
| T0-00 (1197) | Tuning Mode Selection | <p><b>V/f</b> <b>CL-V/f</b> <b>OLV</b> <b>CLV</b> <b>AOLV</b> <b>OLV/PM</b> <b>AOLV/PM</b> <b>CLV/PM</b> <b>EZOLV</b></p> <p>Sets the type of Auto-Tuning.<br/>0 : Motor Parameter Tuning<br/>1 : Control Tuning</p> | 0<br>(0, 1)     | 540  |

### ◆ T1: Induction Motor Auto-Tuning

| No. (Hex.)   | Name                       | Description   | Default (Range)  | Ref. |
|--------------|----------------------------|---|--|------|
| T1-00 (0700) | Motor 1/Motor 2 Selection  | <p><b>V/f</b> <b>CL-V/f</b> <b>OLV</b> <b>CLV</b> <b>AOLV</b> <b>OLV/PM</b> <b>AOLV/PM</b> <b>CLV/PM</b> <b>EZOLV</b></p> <p>Sets which motor to tune when motor 1/2 switching is enabled.<br/>You can only use the keypad to set this parameter. You cannot use external input terminals to set it.</p> <p><b>Note:</b><br/>This parameter is available when <math>H1-xx = 16</math> [Motor 2 Selection]. The keypad will not show this parameter when <math>H1-xx \neq 16</math>.<br/>1 : Motor 1<br/>2 : Motor 2</p> | 1<br>(1, 2)  | 540  |
| T1-01 (0701) | Tuning Mode Selection      | <p><b>V/f</b> <b>CL-V/f</b> <b>OLV</b> <b>CLV</b> <b>AOLV</b> <b>OLV/PM</b> <b>AOLV/PM</b> <b>CLV/PM</b> <b>EZOLV</b></p> <p>Sets the type of Auto-Tuning.<br/>0 : Rotational Auto-Tuning<br/>1 : Stationary Auto-Tuning 1<br/>2 : Line-to-Line Resistance</p>  | Determined by A1-02<br>(Determined by A1-02)   | 541  |
| T1-02 (0702) | Motor Rated Power          | <p><b>V/f</b> <b>CL-V/f</b> <b>OLV</b> <b>CLV</b> <b>AOLV</b> <b>OLV/PM</b> <b>AOLV/PM</b> <b>CLV/PM</b> <b>EZOLV</b></p> <p>Sets the motor rated output power in the unit set by <math>o1-58</math> [Motor Power Unit Selection].</p>  | Determined by o2-04, C6-01<br>(0.00 – 650.00 kW)                                       | 541  |
| T1-03 (0703) | Motor Rated Voltage        | <p><b>V/f</b> <b>CL-V/f</b> <b>OLV</b> <b>CLV</b> <b>AOLV</b> <b>OLV/PM</b> <b>AOLV/PM</b> <b>CLV/PM</b> <b>EZOLV</b></p> <p>Sets the rated voltage (V) of the motor. Enter the base speed voltage for constant output motors.</p>  | Determined by o2-04, C6-01<br>(200 V Class: 0.0 - 255.5 V, 400 V Class: 0.0 - 511.0 V) | 541  |
| T1-04 (0704) | Motor Rated Current        | <p><b>V/f</b> <b>CL-V/f</b> <b>OLV</b> <b>CLV</b> <b>AOLV</b> <b>OLV/PM</b> <b>AOLV/PM</b> <b>CLV/PM</b> <b>EZOLV</b></p> <p>Sets the rated current (A) of the motor.</p>   | Determined by o2-04<br>(10% to 200% of the drive rated current)                        | 541  |
| T1-05 (0705) | Motor Base Frequency       | <p><b>V/f</b> <b>CL-V/f</b> <b>OLV</b> <b>CLV</b> <b>AOLV</b> <b>OLV/PM</b> <b>AOLV/PM</b> <b>CLV/PM</b> <b>EZOLV</b></p> <p>Sets the base frequency (Hz) of the motor.</p>   | 60.0 Hz<br>(0.0 - 590.0 Hz)  | 541  |
| T1-06 (0706) | Number of Motor Poles      | <p><b>V/f</b> <b>CL-V/f</b> <b>OLV</b> <b>CLV</b> <b>AOLV</b> <b>OLV/PM</b> <b>AOLV/PM</b> <b>CLV/PM</b> <b>EZOLV</b></p> <p>Sets the number of motor poles.</p>  | 4<br>(2 to 120)  | 542  |
| T1-07 (0707) | Motor Base Speed           | <p><b>V/f</b> <b>CL-V/f</b> <b>OLV</b> <b>CLV</b> <b>AOLV</b> <b>OLV/PM</b> <b>AOLV/PM</b> <b>CLV/PM</b> <b>EZOLV</b></p> <p>Sets the motor base speed for Auto-Tuning (<math>\text{min}^{-1}</math> (r/min)).</p>  | 1750 $\text{min}^{-1}$ (r/min)<br>(0 - 35400 $\text{min}^{-1}$ (r/min))                | 542  |
| T1-08 (0708) | Encoder Pulse Count (PPR)  | <p><b>V/f</b> <b>CL-V/f</b> <b>OLV</b> <b>CLV</b> <b>AOLV</b> <b>OLV/PM</b> <b>AOLV/PM</b> <b>CLV/PM</b> <b>EZOLV</b></p> <p>Sets the number of PG (pulse generator, encoder) pulses.</p>   | 1024 ppr<br>(0 - 60,000 ppr)   | 542  |
| T1-09 (0709) | Motor No-Load Current      | <p><b>V/f</b> <b>CL-V/f</b> <b>OLV</b> <b>CLV</b> <b>AOLV</b> <b>OLV/PM</b> <b>AOLV/PM</b> <b>CLV/PM</b> <b>EZOLV</b></p> <p>Sets the no-load current of the motor.</p>   | -<br>(0A - T1-04; max. of 2999.9)  | 542  |
| T1-10 (070A) | Motor Rated Slip Frequency | <p><b>V/f</b> <b>CL-V/f</b> <b>OLV</b> <b>CLV</b> <b>AOLV</b> <b>OLV/PM</b> <b>AOLV/PM</b> <b>CLV/PM</b> <b>EZOLV</b></p> <p>Sets motor rated slip.</p>   | -<br>(0.000 - 20.000 Hz)   | 542  |
| T1-11 (070B) | Motor Iron Loss            | <p><b>V/f</b> <b>CL-V/f</b> <b>OLV</b> <b>CLV</b> <b>AOLV</b> <b>OLV/PM</b> <b>AOLV/PM</b> <b>CLV/PM</b> <b>EZOLV</b></p> <p>Sets the iron loss for calculating the energy-saving coefficient.</p>  | Determined by E2-11 or E4-11<br>(0 - 65535 W)  | 542  |



| No. (Hex.)   | Name                | Description   | Default (Range)   | Ref. |
|--------------|---------------------|---|---|------|
| T1-12 (0BDB) | Test Mode Selection | <p><input type="checkbox"/> V/f <input type="checkbox"/> CL-V/f <input checked="" type="checkbox"/> OLV <input checked="" type="checkbox"/> CLV <input type="checkbox"/> AOLV <input type="checkbox"/> OLV/PM <input type="checkbox"/> AOLV/PM <input type="checkbox"/> CLV/PM <input type="checkbox"/> EZOLV</p> <p>Sets the function to enable Test Mode after Stationary Auto-Tuning. When you can operate the motor with a light load attached after Stationary Auto-Tuning is complete, enable this parameter.</p> <p><b>Note:</b><br/>You must first set T1-10 [Motor Rated Slip Frequency] = 0 Hz to enable this parameter.</p> <p>0 : No<br/>1 : Yes</p>                                      | 0<br>(0, 1)   | 543  |
| T1-13 (0BDC) | No-load voltage     | <p><input type="checkbox"/> V/f <input type="checkbox"/> CL-V/f <input checked="" type="checkbox"/> OLV <input checked="" type="checkbox"/> CLV <input type="checkbox"/> AOLV <input type="checkbox"/> OLV/PM <input type="checkbox"/> AOLV/PM <input type="checkbox"/> CLV/PM <input type="checkbox"/> EZOLV</p> <p>Sets the no-load voltage of the motor. If no-load voltage is known at rated speed for the motor test report, set the voltage in this parameter. If no-load voltage is unknown, do not change the default value.</p> <p><b>Note:</b><br/>To get the same qualities as a Yaskawa 1000-series drive or previous models, set this parameter = T1-03 [Motor Rated Voltage] value.</p> | T1-03×E1-21<br>(200 V Class: 0.0 - 255.0 V, 400 V Class: 0.0 - 510.0 V) | 543  |

## ◆ T2: PM Motor Auto-Tuning

| No. (Hex.)   | Name                       | Description   | Default (Range)  | Ref. |
|--------------|----------------------------|---|--|------|
| T2-01 (0750) | PM Auto-Tuning Selection   | <p><input type="checkbox"/> V/f <input type="checkbox"/> CL-V/f <input type="checkbox"/> OLV <input type="checkbox"/> CLV <input type="checkbox"/> AOLV <input checked="" type="checkbox"/> OLV/PM <input checked="" type="checkbox"/> AOLV/PM <input checked="" type="checkbox"/> CLV/PM <input type="checkbox"/> EZOLV</p> <p>Sets the type of Auto-Tuning for PM motors.</p> <p>0 : PM Motor Parameter Settings<br/>1 : Stationary (Ld, Lq, R)<br/>2 : PM StaTun for Stator Resistance<br/>3 : Z-Pulse Offset (Pole Position)<br/>4 : PM Rotational Auto-Tuning<br/>5 : High Frequency Injection Auto-Tuning</p> | 0<br>(Determined by A1-02)   | 543  |
| T2-02 (0751) | PM Motor Code Selection    | <p><input type="checkbox"/> V/f <input type="checkbox"/> CL-V/f <input type="checkbox"/> OLV <input type="checkbox"/> CLV <input type="checkbox"/> AOLV <input checked="" type="checkbox"/> OLV/PM <input checked="" type="checkbox"/> AOLV/PM <input checked="" type="checkbox"/> CLV/PM <input type="checkbox"/> EZOLV</p> <p>If the drive is operating a Yaskawa PM motor from the SMRA, SSR1, or SST4 series, enter the PM motor code in accordance with the rotation speed and motor output.</p>   | FFFF<br>(0000 - FFFF)  | 544  |
| T2-03 (0752) | PM Motor Type              | <p><input type="checkbox"/> V/f <input type="checkbox"/> CL-V/f <input type="checkbox"/> OLV <input type="checkbox"/> CLV <input type="checkbox"/> AOLV <input checked="" type="checkbox"/> OLV/PM <input checked="" type="checkbox"/> AOLV/PM <input checked="" type="checkbox"/> CLV/PM <input type="checkbox"/> EZOLV</p> <p>Sets the type of PM motor the drive will operate.</p> <p>0 : IPM motor<br/>1 : SPM motor</p>  | 1<br>(0, 1)  | 544  |
| T2-04 (0730) | PM Motor Rated Power       | <p><input type="checkbox"/> V/f <input type="checkbox"/> CL-V/f <input type="checkbox"/> OLV <input type="checkbox"/> CLV <input type="checkbox"/> AOLV <input checked="" type="checkbox"/> OLV/PM <input checked="" type="checkbox"/> AOLV/PM <input checked="" type="checkbox"/> CLV/PM <input type="checkbox"/> EZOLV</p> <p>Sets the PM motor rated output power in the unit set by o1-58 [Motor Power Unit Selection].</p>   | Determined by o2-04, C6-01<br>(0.00 - 650.00 kW)   | 544  |
| T2-05 (0732) | PM Motor Rated Voltage     | <p><input type="checkbox"/> V/f <input type="checkbox"/> CL-V/f <input type="checkbox"/> OLV <input type="checkbox"/> CLV <input type="checkbox"/> AOLV <input checked="" type="checkbox"/> OLV/PM <input checked="" type="checkbox"/> AOLV/PM <input checked="" type="checkbox"/> CLV/PM <input type="checkbox"/> EZOLV</p> <p>Sets the rated voltage (V) of the motor.</p>  | 200 V Class: 230.0 V, 400 V: 460.0 V<br>(200 V Class: 0.0 - 255.0 V, 400 V Class: 0.0 - 510.0 V) | 544  |
| T2-06 (0733) | PM Motor Rated Current     | <p><input type="checkbox"/> V/f <input type="checkbox"/> CL-V/f <input type="checkbox"/> OLV <input type="checkbox"/> CLV <input type="checkbox"/> AOLV <input checked="" type="checkbox"/> OLV/PM <input checked="" type="checkbox"/> AOLV/PM <input checked="" type="checkbox"/> CLV/PM <input type="checkbox"/> EZOLV</p> <p>Sets the rated current (A) of the motor.</p>  | Determined by o2-04<br>(10% to 200% of the drive rated current)                                  | 544  |
| T2-07 (0753) | PM Motor Base Frequency    | <p><input type="checkbox"/> V/f <input type="checkbox"/> CL-V/f <input type="checkbox"/> OLV <input type="checkbox"/> CLV <input type="checkbox"/> AOLV <input checked="" type="checkbox"/> OLV/PM <input checked="" type="checkbox"/> AOLV/PM <input checked="" type="checkbox"/> CLV/PM <input type="checkbox"/> EZOLV</p> <p>Sets the base frequency (Hz) of the motor.</p>  | 60.0 Hz<br>(0.0 - 590.0 Hz)  | 544  |
| T2-08 (0734) | Number of PM Motor Poles   | <p><input type="checkbox"/> V/f <input type="checkbox"/> CL-V/f <input type="checkbox"/> OLV <input type="checkbox"/> CLV <input type="checkbox"/> AOLV <input checked="" type="checkbox"/> OLV/PM <input checked="" type="checkbox"/> AOLV/PM <input checked="" type="checkbox"/> CLV/PM <input type="checkbox"/> EZOLV</p> <p>Sets the number of motor poles.</p>   | 4<br>(2 - 48)  | 545  |
| T2-09 (0731) | PM Motor Base Speed        | <p><input type="checkbox"/> V/f <input type="checkbox"/> CL-V/f <input type="checkbox"/> OLV <input type="checkbox"/> CLV <input type="checkbox"/> AOLV <input checked="" type="checkbox"/> OLV/PM <input checked="" type="checkbox"/> AOLV/PM <input checked="" type="checkbox"/> CLV/PM <input type="checkbox"/> EZOLV</p> <p>Sets the motor base speed (min<sup>-1</sup> (r/min)).</p>   | 1750 min <sup>-1</sup> (r/min)<br>(0 - 34500 min <sup>-1</sup> (r/min))                          | 545  |
| T2-10 (0754) | PM Motor Stator Resistance | <p><input type="checkbox"/> V/f <input type="checkbox"/> CL-V/f <input type="checkbox"/> OLV <input type="checkbox"/> CLV <input type="checkbox"/> AOLV <input checked="" type="checkbox"/> OLV/PM <input checked="" type="checkbox"/> AOLV/PM <input checked="" type="checkbox"/> CLV/PM <input type="checkbox"/> EZOLV</p> <p>Sets the stator resistance for each motor phase.</p> <p><b>Note:</b><br/>This parameter does not set line-to-line resistance.</p>   | Determined by T2-02<br>(0.000 - 65.000 Ω)  | 545  |
| T2-11 (0735) | PM Motor d-Axis Inductance | <p><input type="checkbox"/> V/f <input type="checkbox"/> CL-V/f <input type="checkbox"/> OLV <input type="checkbox"/> CLV <input type="checkbox"/> AOLV <input checked="" type="checkbox"/> OLV/PM <input checked="" type="checkbox"/> AOLV/PM <input checked="" type="checkbox"/> CLV/PM <input type="checkbox"/> EZOLV</p> <p>Sets the d-axis inductance of the motor on a per phase basis.</p>   | Determined by T2-02<br>(0.00 - 600.00 mH)  | 545  |
| T2-12 (0736) | PM Motor q-Axis Inductance | <p><input type="checkbox"/> V/f <input type="checkbox"/> CL-V/f <input type="checkbox"/> OLV <input type="checkbox"/> CLV <input type="checkbox"/> AOLV <input checked="" type="checkbox"/> OLV/PM <input checked="" type="checkbox"/> AOLV/PM <input checked="" type="checkbox"/> CLV/PM <input type="checkbox"/> EZOLV</p> <p>Sets the q-Axis inductance of the motor on a per phase basis.</p>   | Determined by T2-02<br>(0.00 - 600.00 mH)  | 545  |

## 1.16 T: Motor Tuning

| No. (Hex.)   | Name                           | Description  | Default (Range)                       | Ref. |
|--------------|--------------------------------|--|---------------------------------------|------|
| T2-13 (0755) | Back-EMF Units Selection       | <div style="display: flex; justify-content: space-between; font-size: 0.8em;"> <span>V/f</span> <span>CL-V/f</span> <span>OLV</span> <span>CLV</span> <span>AOLV</span> <span><b>OLV/PM</b></span> <span>AOLV/PM</span> <span>CLV/PM</span> <span>EZOLV</span> </div> <p>Sets the units that the drive uses to set the induced voltage constant.<br/>           0 : mV/min<sup>-1</sup><br/>           1 : mV/(rad/sec)</p>            | 0<br>(0, 1)                           | 545  |
| T2-14 (0737) | Back-EMF Voltage Constant (Ke) | <div style="display: flex; justify-content: space-between; font-size: 0.8em;"> <span>V/f</span> <span>CL-V/f</span> <span>OLV</span> <span>CLV</span> <span>AOLV</span> <span><b>OLV/PM</b></span> <span>AOLV/PM</span> <span>CLV/PM</span> <span>EZOLV</span> </div> <p>Sets the motor induced voltage constant (Ke).</p>   | Determined by T2-13<br>(0.0 - 2000.0) | 545  |
| T2-15 (0756) | Pull-In Current Level          | <div style="display: flex; justify-content: space-between; font-size: 0.8em;"> <span>V/f</span> <span>CL-V/f</span> <span>OLV</span> <span>CLV</span> <span>AOLV</span> <span><b>OLV/PM</b></span> <span>AOLV/PM</span> <span>CLV/PM</span> <span>EZOLV</span> </div> <p>Sets the level of the pull-in current as a percentage of <i>E5-03 [PM Motor Rated Current (FLA)]</i>. Usually it is not necessary to change this setting.</p> | 30%<br>(0 - 120%)                     | 546  |
| T2-16 (0738) | Encoder Pulse Count (PPR)      | <div style="display: flex; justify-content: space-between; font-size: 0.8em;"> <span>V/f</span> <span>CL-V/f</span> <span>OLV</span> <span>CLV</span> <span>AOLV</span> <span>OLV/PM</span> <span>AOLV/PM</span> <span><b>CLV/PM</b></span> <span>EZOLV</span> </div> <p>Sets the number of PG (pulse generator, encoder) pulses.</p>  | 1024 ppr<br>(1 - 15000 ppr)           | 546  |
| T2-17 (0757) | Encoder Z-Pulse Offset         | <div style="display: flex; justify-content: space-between; font-size: 0.8em;"> <span>V/f</span> <span>CL-V/f</span> <span>OLV</span> <span>CLV</span> <span>AOLV</span> <span>OLV/PM</span> <span>AOLV/PM</span> <span>CLV/PM</span> <span>EZOLV</span> </div> <p>Sets the encoder Z-pulse offset (<math>\Delta\theta</math>) (pulse generator, encoder) that is listed on the motor nameplate.</p>                                    | 0.0°<br>(-180.0 - +180.0°)            | 546  |

## ◆ T3: ASR and Inertia Tuning

| No. (Hex.)   | Name                          | Description   | Default (Range)  | Ref. |
|--------------|-------------------------------|---|--|------|
| T3-00 (1198) | Control Loop Tuning Selection | <div style="display: flex; justify-content: space-between; font-size: 0.8em;"> <span>V/f</span> <span>CL-V/f</span> <span>OLV</span> <span>CLV</span> <span>AOLV</span> <span>OLV/PM</span> <span>AOLV/PM</span> <span>CLV/PM</span> <span>EZOLV</span> </div> <p>Sets the type of Control Auto-Tuning.<br/>           0 : Inertia Tuning<br/>           1 : ASR (Speed Regulator)<br/>           2 : Deceleration Rate Tuning<br/>           3 : KEB Tuning<br/> <b>Note:</b><br/>           Settings 0 and 1 are available only when <i>A1-02 = 3, 7 [Control Method Selection = CLV, CLV/PM]</i>.</p>  | 0<br>(0 - 3)   | 546  |
| T3-01 (0760) | Test Signal Frequency         | <div style="display: flex; justify-content: space-between; font-size: 0.8em;"> <span>V/f</span> <span>CL-V/f</span> <span>OLV</span> <span>CLV</span> <span>AOLV</span> <span>OLV/PM</span> <span>AOLV/PM</span> <span>CLV/PM</span> <span>EZOLV</span> </div> <p>Sets the frequency of the test signal applied to the motor during Inertia Tuning. Usually it is not necessary to change this setting.</p>   | 3.0 Hz<br>(0.1 - 20.0 Hz)  | 546  |
| T3-02 (0761) | Test Signal Amplitude         | <div style="display: flex; justify-content: space-between; font-size: 0.8em;"> <span>V/f</span> <span>CL-V/f</span> <span>OLV</span> <span>CLV</span> <span>AOLV</span> <span>OLV/PM</span> <span>AOLV/PM</span> <span>CLV/PM</span> <span>EZOLV</span> </div> <p>Sets the amplitude of the test signal applied to the motor during Inertia Tuning. Usually it is not necessary to change this setting.</p>   | 0.5 rad<br>(0.1 - 10.0 rad)  | 546  |
| T3-03 (0762) | Motor Inertia                 | <div style="display: flex; justify-content: space-between; font-size: 0.8em;"> <span>V/f</span> <span>CL-V/f</span> <span>OLV</span> <span>CLV</span> <span>AOLV</span> <span>OLV/PM</span> <span>AOLV/PM</span> <span>CLV/PM</span> <span>EZOLV</span> </div> <p>Sets the inertia of the motor. This value uses the test signal response to calculate the load inertia.<br/> <b>Note:</b><br/>           The display units for the default setting and setting range are different for different models:<br/>           • 0.0001 kgm<sup>2</sup> units (setting range: 0.0001 kgm<sup>2</sup> to 6.0000 kgm<sup>2</sup>): 2004 to 2021, 4002 to 4012<br/>           • 0.001 kgm<sup>2</sup> units (setting range: 0.001 kgm<sup>2</sup> to 60.000 kgm<sup>2</sup>): 2030 to 2211, 4018 to 4103<br/>           • 0.01 kgm<sup>2</sup> units (setting range: 0.01 kgm<sup>2</sup> to 600.00 kgm<sup>2</sup>): 2257 to 2415, 4140 to 4720</p> | Determined by o2-04, C6-01, and E5-01<br>(0.0001 - 600.00 kgm <sup>2</sup> ) | 547  |
| T3-04 (0763) | System Response Frequency     | <div style="display: flex; justify-content: space-between; font-size: 0.8em;"> <span>V/f</span> <span>CL-V/f</span> <span>OLV</span> <span>CLV</span> <span>AOLV</span> <span>OLV/PM</span> <span>AOLV/PM</span> <span>CLV/PM</span> <span>EZOLV</span> </div> <p>This parameter uses the load inertia value from the Inertia Tuning process to automatically calculate and set <i>C5-01 [ASR Proportional Gain I]</i>.</p>   | 10.0 Hz<br>(0.1 - 50.0 Hz)   | 547  |

## ◆ T4: EZ Tuning

| No. (Hex.)      | Name                         | Description   | Default (Range)  | Ref. |
|-----------------|------------------------------|---|--|------|
| T4-01<br>(3130) | EZ Tuning Mode Selection     | <div style="display: flex; justify-content: space-between; font-size: 0.8em; margin-bottom: 5px;"> <span>V/f</span> <span>CL-V/f</span> <span>OLV</span> <span>CLV</span> <span>AOLV</span> <span>OLV/PM</span> <span>AOLV/PM</span> <span>CLV/PM</span> <span style="background-color: #333; color: white; padding: 2px;">EZOLV</span> </div> Sets the type of Auto-Tuning for EZOLV control.<br>0 : Motor Parameter Setting<br>1 : Line-to-Line Resistance    | 0<br>(0, 1)  | 547  |
| T4-02<br>(3131) | Motor Type Selection         | <div style="display: flex; justify-content: space-between; font-size: 0.8em; margin-bottom: 5px;"> <span>V/f</span> <span>CL-V/f</span> <span>OLV</span> <span>CLV</span> <span>AOLV</span> <span>OLV/PM</span> <span>AOLV/PM</span> <span>CLV/PM</span> <span style="background-color: #333; color: white; padding: 2px;">EZOLV</span> </div> Sets the type of motor.<br>0 : Induction (IM)<br>1 : Permanent Magnet (PM)<br>2 : Synchronous Reluctance (SynRM) | 0<br>(0, 1, 2)   | 548  |
| T4-04<br>(3133) | Motor Rated Revolutions      | <div style="display: flex; justify-content: space-between; font-size: 0.8em; margin-bottom: 5px;"> <span>V/f</span> <span>CL-V/f</span> <span>OLV</span> <span>CLV</span> <span>AOLV</span> <span>OLV/PM</span> <span>AOLV/PM</span> <span>CLV/PM</span> <span style="background-color: #333; color: white; padding: 2px;">EZOLV</span> </div> Sets rated rotation speed (min <sup>-1</sup> ) of the motor.   | -<br>((40 Hz to 120 Hz) × 60 × 2/E9-08)  | 548  |
| T4-05<br>(3134) | Motor Rated Frequency        | <div style="display: flex; justify-content: space-between; font-size: 0.8em; margin-bottom: 5px;"> <span>V/f</span> <span>CL-V/f</span> <span>OLV</span> <span>CLV</span> <span>AOLV</span> <span>OLV/PM</span> <span>AOLV/PM</span> <span>CLV/PM</span> <span style="background-color: #333; color: white; padding: 2px;">EZOLV</span> </div> Sets the rated frequency (Hz) of the motor.  | Determined by E9-01 and o2-04<br>(40.0 - 120.0 Hz)   | 548  |
| T4-06<br>(3135) | Motor Rated Voltage          | <div style="display: flex; justify-content: space-between; font-size: 0.8em; margin-bottom: 5px;"> <span>V/f</span> <span>CL-V/f</span> <span>OLV</span> <span>CLV</span> <span>AOLV</span> <span>OLV/PM</span> <span>AOLV/PM</span> <span>CLV/PM</span> <span style="background-color: #333; color: white; padding: 2px;">EZOLV</span> </div> Sets the rated voltage (V) of the motor.   | 200 V Class: 230.0 V, 400 V: 460.0 V<br>(200 V Class: 0.0 - 255.0 V, 400 V Class: 0.0 - 510.0 V) | 548  |
| T4-07<br>(3136) | PM Motor Rated Current (FLA) | <div style="display: flex; justify-content: space-between; font-size: 0.8em; margin-bottom: 5px;"> <span>V/f</span> <span>CL-V/f</span> <span>OLV</span> <span>CLV</span> <span>AOLV</span> <span>OLV/PM</span> <span>AOLV/PM</span> <span>CLV/PM</span> <span style="background-color: #333; color: white; padding: 2px;">EZOLV</span> </div> Sets the rated current (A) of the motor.   | Determined by o2-04, C6-01<br>(10% to 200% of the drive rated current)                           | 548  |
| T4-08<br>(3137) | PM Motor Rated Power (kW)    | <div style="display: flex; justify-content: space-between; font-size: 0.8em; margin-bottom: 5px;"> <span>V/f</span> <span>CL-V/f</span> <span>OLV</span> <span>CLV</span> <span>AOLV</span> <span>OLV/PM</span> <span>AOLV/PM</span> <span>CLV/PM</span> <span style="background-color: #333; color: white; padding: 2px;">EZOLV</span> </div> Sets the motor rated power in the unit set by o1-58 [Motor Power Unit Selection].                                | Determined by E9-10<br>(0.10 - 650.00 kW)  | 548  |
| T4-09<br>(3138) | Number of Motor Poles        | <div style="display: flex; justify-content: space-between; font-size: 0.8em; margin-bottom: 5px;"> <span>V/f</span> <span>CL-V/f</span> <span>OLV</span> <span>CLV</span> <span>AOLV</span> <span>OLV/PM</span> <span>AOLV/PM</span> <span>CLV/PM</span> <span style="background-color: #333; color: white; padding: 2px;">EZOLV</span> </div> Sets the number of motor poles.  | Determined by E9-01<br>(2 - 48)  | 548  |

## 1.17 U: Monitors

### ◆ U1: Operation Status Monitors

| No. (Hex.)      | Name                | Description  | MFAO Signal Level  |
|-----------------|---------------------|--|--|
| U1-01<br>(0040) | Frequency reference | <p><b>V/f</b> <b>CL-V/f</b> <b>OLV</b> <b>CLV</b> <b>AOLV</b> <b>OLV/PM</b> <b>AOLV/PM</b> <b>CLV/PM</b> <b>EZOLV</b></p> <p>Shows the actual frequency reference value. Parameter <i>o1-03</i> [Keypad Display Unit Selection] sets the display units.<br/>Unit: 0.01 Hz</p>  | 10 V = Maximum frequency (-10 V to +10 V)                    |
| U1-02<br>(0041) | Output Frequency    | <p><b>V/f</b> <b>CL-V/f</b> <b>OLV</b> <b>CLV</b> <b>AOLV</b> <b>OLV/PM</b> <b>AOLV/PM</b> <b>CLV/PM</b> <b>EZOLV</b></p> <p>Shows the actual output frequency. Parameter <i>o1-03</i> [Keypad Display Unit Selection] sets the display units.<br/>Unit: 0.01 Hz</p>   | 10 V = Maximum frequency (-10 V to +10 V)                    |
| U1-03<br>(0042) | Output Current      | <p><b>V/f</b> <b>CL-V/f</b> <b>OLV</b> <b>CLV</b> <b>AOLV</b> <b>OLV/PM</b> <b>AOLV/PM</b> <b>CLV/PM</b> <b>EZOLV</b></p> <p>Shows the actual output current.<br/>The keypad shows the value of <i>U1-03</i> in amperes (A). When looking at the monitor through MEMOBUS/Modbus communications, the current is "8192 = drive rated current (A)." Calculate the current from the monitor value that is in at MEMOBUS/Modbus communications using "Numerals being displayed / 8192 × drive rated current (A)."<br/>Unit: Determined by the drive model.<br/>• 0.01 A: 2004 to 2042, 4002 to 4023<br/>• 0.1 A: 2056 to 2415, 4031 to 4720</p>   | 10 V = Drive rated current                                   |
| U1-04<br>(0043) | Control Method      | <p><b>V/f</b> <b>CL-V/f</b> <b>OLV</b> <b>CLV</b> <b>AOLV</b> <b>OLV/PM</b> <b>AOLV/PM</b> <b>CLV/PM</b> <b>EZOLV</b></p> <p>Shows the drive control method.<br/>0 : V/f Control<br/>1 : V/f Control with Encoder<br/>2 : Open Loop Vector<br/>3 : Closed Loop Vector<br/>4 : Advanced Open Loop Vector<br/>5 : PM Open Loop Vector<br/>6 : PM Advanced Open Loop Vector<br/>7 : PM Closed Loop Vector<br/>8 : EZ Vector Control</p>   | No signal output available                                   |
| U1-05<br>(0044) | Motor Speed         | <p><b>V/f</b> <b>CL-V/f</b> <b>OLV</b> <b>CLV</b> <b>AOLV</b> <b>OLV/PM</b> <b>AOLV/PM</b> <b>CLV/PM</b> <b>EZOLV</b></p> <p>Shows the actual detected motor speed. Parameter <i>o1-03</i> [Keypad Display Unit Selection] sets the display units.<br/>Unit: 0.01 Hz</p>   | 10 V = Maximum frequency (-10 V to +10 V)                    |
| U1-06<br>(0045) | Output Voltage Ref  | <p><b>V/f</b> <b>CL-V/f</b> <b>OLV</b> <b>CLV</b> <b>AOLV</b> <b>OLV/PM</b> <b>AOLV/PM</b> <b>CLV/PM</b> <b>EZOLV</b></p> <p>Shows the output voltage reference.<br/>Unit: 0.1 V</p>   | 200 V class: 10 V = 200 Vrms<br>400 V class: 10 V = 400 Vrms |
| U1-07<br>(0046) | DC Bus Voltage      | <p><b>V/f</b> <b>CL-V/f</b> <b>OLV</b> <b>CLV</b> <b>AOLV</b> <b>OLV/PM</b> <b>AOLV/PM</b> <b>CLV/PM</b> <b>EZOLV</b></p> <p>Shows the DC bus voltage.<br/>Unit: 1 V</p>   | 200 V class: 10 V = 400 V<br>400 V class: 10 V = 800 V       |
| U1-08<br>(0047) | Output Power        | <p><b>V/f</b> <b>CL-V/f</b> <b>OLV</b> <b>CLV</b> <b>AOLV</b> <b>OLV/PM</b> <b>AOLV/PM</b> <b>CLV/PM</b> <b>EZOLV</b></p> <p>Shows the internally-calculated output power.<br/>Changing the setting of <i>A1-02</i> [Control Method Selection] also changes the signal level of the analog output.<br/>• <i>A1-02</i> = 0, 1: Drive capacity (kW)<br/>• <i>A1-02</i> = 2, 3, 4: Motor Rated Power [E2-11] (kW)<br/>• <i>A1-02</i> = 5, 6, 7: PM Motor Rated Power [E5-02] (kW)<br/>• <i>A1-02</i> = 8: Motor Rated Power [E9-07] (kW)<br/>Unit: The display units are different for different models:<br/>• 0.01 kW: 2004 to 2042, 4002 to 4023<br/>• 0.1 kW: 2056 to 2415, 4031 to 4720</p> | 10 V: Drive capacity (motor rated power) kW (-10 V to +10 V) |
| U1-09<br>(0048) | Torque Reference    | <p><b>V/f</b> <b>CL-V/f</b> <b>OLV</b> <b>CLV</b> <b>AOLV</b> <b>OLV/PM</b> <b>AOLV/PM</b> <b>CLV/PM</b> <b>EZOLV</b></p> <p>Shows the internal torque reference value.<br/>Unit: 0.1%</p>   | 10 V = Motor rated torque (-10 V to +10 V)                   |

| No. (Hex.)      | Name                   | Description  | MFAO Signal Level                         |
|-----------------|------------------------|--|---|
| U1-10<br>(0049) | Input Terminal Status  | <p><b>V/f</b> <b>CL-V/f</b> <b>OLV</b> <b>CLV</b> <b>AOLV</b> <b>OLV/PM</b> <b>AOLV/PM</b> <b>CLV/PM</b> <b>EZOLV</b></p> <p>Shows the status of the MFDI terminal where 1 = (ON) and 0 = (OFF).<br/>For example, <i>U1-10</i> shows "00000011" when terminals S1 and S2 are ON.<br/>bit 0 : Terminal S1 (MFDI 1)<br/>bit 1 : Terminal S2 (MFDI 2)<br/>bit 2 : Terminal S3 (MFDI 3)<br/>bit 3 : Terminal S4 (MFDI 4)<br/>bit 4 : Terminal S5 (MFDI 5)<br/>bit 5 : Terminal S6 (MFDI 6)<br/>bit 6 : Terminal S7 (MFDI 7)<br/>bit 7 : Terminal S8 (MFDI 8)</p>   | No signal output available                |
| U1-11<br>(004A) | Output Terminal Status | <p><b>V/f</b> <b>CL-V/f</b> <b>OLV</b> <b>CLV</b> <b>AOLV</b> <b>OLV/PM</b> <b>AOLV/PM</b> <b>CLV/PM</b> <b>EZOLV</b></p> <p>Shows the status of the MFDO terminal where 1 = (ON) and 0 = (OFF).<br/>For example, <i>U1-11</i> shows "00000011" when terminals M1 and M3 are ON.<br/><b>Note:</b><br/>When <i>H2-xx = 100 to 19F</i> [Inverse Output of Function], the value before inversion is displayed.<br/>bit 0 : Terminals M1-M2<br/>bit 1 : Terminals M3-M4<br/>bit 2 : Terminals M5-M6<br/>bit 3 : Not used (normal value of 0).<br/>bit 4 : Not used (normal value of 0).<br/>bit 5 : Not used (normal value of 0).<br/>bit 6 : Not used (normal value of 0).<br/>bit 7 : Fault relay MA/MB-MC</p> | No signal output available                |
| U1-12<br>(004B) | Drive Status           | <p><b>V/f</b> <b>CL-V/f</b> <b>OLV</b> <b>CLV</b> <b>AOLV</b> <b>OLV/PM</b> <b>AOLV/PM</b> <b>CLV/PM</b> <b>EZOLV</b></p> <p>Shows drive status where 1 = (ON) and 0 = (OFF).<br/>For example, <i>U1-12</i> shows "00000101" during run with the Reverse Run command.<br/>bit 0 : During Run<br/>bit 1 : During zero-speed<br/>bit 2 : During reverse<br/>bit 3 : During fault reset signal input<br/>bit 4 : During speed agreement<br/>bit 5 : Drive ready<br/>bit 6 : During minor fault detection<br/>bit 7 : During fault detection</p>   | No signal output available                |
| U1-13<br>(004E) | Terminal A1 Level      | <p><b>V/f</b> <b>CL-V/f</b> <b>OLV</b> <b>CLV</b> <b>AOLV</b> <b>OLV/PM</b> <b>AOLV/PM</b> <b>CLV/PM</b> <b>EZOLV</b></p> <p>Shows the signal level of terminal A1.<br/>Unit: 0.1%</p>   | 10 V = 100% (-10 V to +10 V)              |
| U1-14<br>(004F) | Terminal A2 Level      | <p><b>V/f</b> <b>CL-V/f</b> <b>OLV</b> <b>CLV</b> <b>AOLV</b> <b>OLV/PM</b> <b>AOLV/PM</b> <b>CLV/PM</b> <b>EZOLV</b></p> <p>Shows the signal level of terminal A2.<br/>Unit: 0.1%</p>   | 10 V = 100% (-10 V to +10 V)              |
| U1-15<br>(0050) | Terminal A3 Level      | <p><b>V/f</b> <b>CL-V/f</b> <b>OLV</b> <b>CLV</b> <b>AOLV</b> <b>OLV/PM</b> <b>AOLV/PM</b> <b>CLV/PM</b> <b>EZOLV</b></p> <p>Shows the signal level of terminal A3.<br/>Unit: 0.1%</p>   | 0 V = 100% (-10 V to +10 V)               |
| U1-16<br>(0053) | SFS Output Frequency   | <p><b>V/f</b> <b>CL-V/f</b> <b>OLV</b> <b>CLV</b> <b>AOLV</b> <b>OLV/PM</b> <b>AOLV/PM</b> <b>CLV/PM</b> <b>EZOLV</b></p> <p>Shows the output frequency after soft start. Shows the frequency with acceleration and deceleration times and S-curves. Parameter <i>o1-03</i> [Keypad Display Unit Selection] sets the display units.<br/>Unit: 0.01 Hz</p>  | 10 V = Maximum frequency (-10 V to +10 V) |
| U1-17<br>(0058) | DI-A3 Input Status     | <p><b>V/f</b> <b>CL-V/f</b> <b>OLV</b> <b>CLV</b> <b>AOLV</b> <b>OLV/PM</b> <b>AOLV/PM</b> <b>CLV/PM</b> <b>EZOLV</b></p> <p>Shows the reference value input from DI-A3 option.<br/>Shows the input signal for DI-A3 in hexadecimal as set in <i>F3-01</i> [Digital Input Function Selection].<br/>3FFFF: Set (1 bit) + Sign (1 bit) + 16 bit</p>  | No signal output available                |
| U1-18<br>(0061) | oPE Fault Parameter    | <p><b>V/f</b> <b>CL-V/f</b> <b>OLV</b> <b>CLV</b> <b>AOLV</b> <b>OLV/PM</b> <b>AOLV/PM</b> <b>CLV/PM</b> <b>EZOLV</b></p> <p>Shows the parameter number that caused the <i>oPE02</i> [Parameter Range Setting Error] or <i>oPE08</i> [Parameter Selection Error].</p>  | No signal output available                |

## 1.17 U: Monitors

| No. (Hex.)          | Name                      | Description  | MFAO Signal Level  |
|---------------------|---------------------------|--|--|
| U1-19 (0066)        | MEMOBUS/Modbus Error Code | <p><b>V/f</b> <b>CL-V/f</b> <b>OLV</b> <b>CLV</b> <b>AOLV</b> <b>OLV/PM</b> <b>AOLV/PM</b> <b>CLV/PM</b> <b>EZOLV</b></p> <p>Shows the contents of the MEMOBUS/Modbus communication error where 1 = (error) and 0 = (no error).<br/>For example, <i>U1-19</i> shows "00000001" when a CRC error occurs.<br/>bit 0 : CRC Error<br/>bit 1 : Data Length Error<br/>bit 2 : Not used (normal value of 0).<br/>bit 3 : Parity Error<br/>bit 4 : Overrun Error<br/>bit 5 : Framing Error<br/>bit 6 : Timed Out<br/>bit 7 : Not used (normal value of 0).</p> | No signal output available                                   |
| U1-21 (0077)        | AI-A3 Term V1 Level       | <p><b>V/f</b> <b>CL-V/f</b> <b>OLV</b> <b>CLV</b> <b>AOLV</b> <b>OLV/PM</b> <b>AOLV/PM</b> <b>CLV/PM</b> <b>EZOLV</b></p> <p>Shows the analog reference of terminal V1 on analog input option card AI-A3.<br/>Unit: 0.1%</p>   | 10 V = 100% (-10 V to +10 V)                                 |
| U1-22 (072A)        | AI-A3 Term V2 Level       | <p><b>V/f</b> <b>CL-V/f</b> <b>OLV</b> <b>CLV</b> <b>AOLV</b> <b>OLV/PM</b> <b>AOLV/PM</b> <b>CLV/PM</b> <b>EZOLV</b></p> <p>Shows the analog reference of terminal V2 on analog input option card AI-A3.<br/>Unit: 0.1%</p>   | 10 V = 100% (-10 V to +10 V)                                 |
| U1-23 (072B)        | AI-A3 Term V3 Level       | <p><b>V/f</b> <b>CL-V/f</b> <b>OLV</b> <b>CLV</b> <b>AOLV</b> <b>OLV/PM</b> <b>AOLV/PM</b> <b>CLV/PM</b> <b>EZOLV</b></p> <p>Shows the analog reference of terminal V3 on analog input option card AI-A3.<br/>Unit: 0.1%</p>   | 10 V = 100% (-10 V to +10 V)                                 |
| U1-24 (007D)        | Input Pulse Monitor       | <p><b>V/f</b> <b>CL-V/f</b> <b>OLV</b> <b>CLV</b> <b>AOLV</b> <b>OLV/PM</b> <b>AOLV/PM</b> <b>CLV/PM</b> <b>EZOLV</b></p> <p>Shows the frequency to pulse train input terminal RP.<br/>Unit: 1 Hz</p>  | Determined by H6-02  |
| U1-25 (004D)        | SoftwareNumber Flash      | <p><b>V/f</b> <b>CL-V/f</b> <b>OLV</b> <b>CLV</b> <b>AOLV</b> <b>OLV/PM</b> <b>AOLV/PM</b> <b>CLV/PM</b> <b>EZOLV</b></p> <p>Shows the FLASH ID.</p>   | No signal output available                                   |
| U1-26 (005B)        | SoftwareNumber ROM        | <p><b>V/f</b> <b>CL-V/f</b> <b>OLV</b> <b>CLV</b> <b>AOLV</b> <b>OLV/PM</b> <b>AOLV/PM</b> <b>CLV/PM</b> <b>EZOLV</b></p> <p>Shows the ROM ID.</p>   | No signal output available                                   |
| U1-50 (1199) Expert | Virtual Analog Input      | <p><b>V/f</b> <b>CL-V/f</b> <b>OLV</b> <b>CLV</b> <b>AOLV</b> <b>OLV/PM</b> <b>AOLV/PM</b> <b>CLV/PM</b> <b>EZOLV</b></p> <p>Shows the virtual analog input value.</p>   | Determined by H7-40  |
| U1-91 (154E) Expert | Output Voltage            | <p><b>V/f</b> <b>CL-V/f</b> <b>OLV</b> <b>CLV</b> <b>AOLV</b> <b>OLV/PM</b> <b>AOLV/PM</b> <b>CLV/PM</b> <b>EZOLV</b></p> <p>Shows the drive internal output voltage reference.<br/>Unit: 0.1 V</p>  | 200 V class: 10 V = 200 Vrms<br>400 V class: 10 V = 400 Vrms |

## ◆ U2: Fault Trace

| No. (Hex.)   | Name                 | Description  | MFAO Signal Level          |
|--------------|----------------------|--|----------------------------|
| U2-01 (0080) | Current Fault        | <p><b>V/f</b> <b>CL-V/f</b> <b>OLV</b> <b>CLV</b> <b>AOLV</b> <b>OLV/PM</b> <b>AOLV/PM</b> <b>CLV/PM</b> <b>EZOLV</b></p> <p>Shows the fault that the drive has when viewing the monitor.</p>  | No signal output available |
| U2-02 (0081) | Previous Fault       | <p><b>V/f</b> <b>CL-V/f</b> <b>OLV</b> <b>CLV</b> <b>AOLV</b> <b>OLV/PM</b> <b>AOLV/PM</b> <b>CLV/PM</b> <b>EZOLV</b></p> <p>Shows the fault that occurred most recently.</p>  | No signal output available |
| U2-03 (0082) | Freq Reference@Fault | <p><b>V/f</b> <b>CL-V/f</b> <b>OLV</b> <b>CLV</b> <b>AOLV</b> <b>OLV/PM</b> <b>AOLV/PM</b> <b>CLV/PM</b> <b>EZOLV</b></p> <p>Shows the frequency reference at the fault that occurred most recently.<br/>Use <i>U1-01 [Frequency Reference]</i> to monitor the actual frequency reference value.<br/>Unit: 0.01 Hz</p> | No signal output available |
| U2-04 (0083) | Output Freq @ Fault  | <p><b>V/f</b> <b>CL-V/f</b> <b>OLV</b> <b>CLV</b> <b>AOLV</b> <b>OLV/PM</b> <b>AOLV/PM</b> <b>CLV/PM</b> <b>EZOLV</b></p> <p>Shows the output frequency at the fault that occurred most recently.<br/>Use <i>U1-02 [Output Frequency]</i> to monitor the actual output frequency.<br/>Unit: 0.01 Hz</p>                | No signal output available |

| No. (Hex.)      | Name                           | Description  | MFAO Signal Level          |
|-----------------|--------------------------------|--|----------------------------|
| U2-05<br>(0084) | Output Current@Fault           | <p><b>V/f</b> <b>CL-V/f</b> <b>OLV</b> <b>CLV</b> <b>AOLV</b> <b>OLV/PM</b> <b>AOLV/PM</b> <b>CLV/PM</b> <b>EZOLV</b></p> <p>Shows the output current at the fault that occurred most recently.<br/>Use <i>U1-03 [Output Current]</i> to monitor the actual output current. The keypad shows the value of <i>U1-03</i> in amperes (A).<br/>When looking at the monitor through MEMOBUS/Modbus communications, the current is "8192 = drive rated current (A)". Calculate the current from the monitor value that is in at MEMOBUS/Modbus communications using "Numerals being displayed / 8192 × drive rated current (A)".<br/>Unit: Determined by the drive model.<br/>• 0.01 A: 2004 to 2042, 4002 to 4023<br/>• 0.1 A: 2056 to 2415, 4031 to 4720</p> | No signal output available |
| U2-06<br>(0085) | Motor Speed @ Fault            | <p><b>V/f</b> <b>CL-V/f</b> <b>OLV</b> <b>CLV</b> <b>AOLV</b> <b>OLV/PM</b> <b>AOLV/PM</b> <b>CLV/PM</b> <b>EZOLV</b></p> <p>Shows the motor speed at the fault that occurred most recently.<br/>Use <i>U1-05 [Motor Speed]</i> to monitor the actual motor speed.<br/>Unit: 0.01 Hz</p>   | No signal output available |
| U2-07<br>(0086) | Output Voltage@Fault           | <p><b>V/f</b> <b>CL-V/f</b> <b>OLV</b> <b>CLV</b> <b>AOLV</b> <b>OLV/PM</b> <b>AOLV/PM</b> <b>CLV/PM</b> <b>EZOLV</b></p> <p>Shows the output voltage reference at the fault that occurred most recently.<br/>Use <i>U1-06 [Output Voltage Ref]</i> to monitor the actual output voltage reference.<br/>Unit: 0.1 V</p>  | No signal output available |
| U2-08<br>(0087) | DC Bus Voltage@Fault           | <p><b>V/f</b> <b>CL-V/f</b> <b>OLV</b> <b>CLV</b> <b>AOLV</b> <b>OLV/PM</b> <b>AOLV/PM</b> <b>CLV/PM</b> <b>EZOLV</b></p> <p>Shows the DC bus voltage at the fault that occurred most recently.<br/>Use <i>U1-07 [DC Bus Voltage]</i> to monitor the actual DC bus voltage.<br/>Unit: 1 V</p>  | No signal output available |
| U2-09<br>(0088) | Output Power @ Fault           | <p><b>V/f</b> <b>CL-V/f</b> <b>OLV</b> <b>CLV</b> <b>AOLV</b> <b>OLV/PM</b> <b>AOLV/PM</b> <b>CLV/PM</b> <b>EZOLV</b></p> <p>Shows the output power at the fault that occurred most recently.<br/>Use <i>U1-08 [Output Power]</i> to monitor the actual output power.<br/>Unit: 0.1 kW</p>   | No signal output available |
| U2-10<br>(0089) | Torque Ref @ Fault             | <p><b>V/f</b> <b>CL-V/f</b> <b>OLV</b> <b>CLV</b> <b>AOLV</b> <b>OLV/PM</b> <b>AOLV/PM</b> <b>CLV/PM</b> <b>EZOLV</b></p> <p>Shows the torque reference at the fault that occurred most recently as a percentage of the motor rated torque.<br/>Use <i>U1-09 [Torque Reference]</i> to monitor the actual torque reference.<br/>Unit: 0.1%</p>   | No signal output available |
| U2-11<br>(008A) | Input Terminal Status @ Fault  | <p><b>V/f</b> <b>CL-V/f</b> <b>OLV</b> <b>CLV</b> <b>AOLV</b> <b>OLV/PM</b> <b>AOLV/PM</b> <b>CLV/PM</b> <b>EZOLV</b></p> <p>Shows the status of the MFDI terminals at the most recent fault where 1 = (ON) and 0 = (OFF).<br/>For example, <i>U2-11</i> shows "00000011" when terminals S1 and S2 are ON.<br/>Use <i>U1-10 [Input Terminal Status]</i> to monitor the actual MFDI terminal status.<br/>bit 0 : Terminal S1<br/>bit 1 : Terminal S2<br/>bit 2 : Terminal S3<br/>bit 3 : Terminal S4<br/>bit 4 : Terminal S5<br/>bit 5 : Terminal S6<br/>bit 6 : Terminal S7<br/>bit 7 : Terminal S8</p>  | No signal output available |
| U2-12<br>(008B) | Output Terminal Status @ Fault | <p><b>V/f</b> <b>CL-V/f</b> <b>OLV</b> <b>CLV</b> <b>AOLV</b> <b>OLV/PM</b> <b>AOLV/PM</b> <b>CLV/PM</b> <b>EZOLV</b></p> <p>Shows the status of the MFDO terminals at the most recent fault where 1 = (ON) and 0 = (OFF).<br/>For example, <i>U2-12</i> shows "00000011" when terminals M1 and M3 are ON.<br/>Use <i>U1-11 [Output Terminal Status]</i> to monitor the actual MFDO terminal status.<br/>bit 0 : Terminals M1-M2<br/>bit 1 : Terminals M3-M4<br/>bit 2 : Terminals M5-M6<br/>bit 3 : Not used (normal value of 0).<br/>bit 4 : Not used (normal value of 0).<br/>bit 5 : Not used (normal value of 0).<br/>bit 6 : Not used (normal value of 0).<br/>bit 7 : Fault relay MA/MB-MC</p>  | No signal output available |

## 1.17 U: Monitors

| No. (Hex.)                | Name                     | Description   | MFAO Signal Level          |
|---------------------------|--------------------------|---|----------------------------|
| U2-13<br>(008C)           | Operation Status @ Fault | <p><b>V/f</b> <b>CL-V/f</b> <b>OLV</b> <b>CLV</b> <b>AOLV</b> <b>OLV/PM</b> <b>AOLV/PM</b> <b>CLV/PM</b> <b>EZOLV</b></p> <p>Shows the status of the MFDO terminals at the most recent fault where 1 = (ON) and 0 = (OFF).<br/>For example, U2-13 shows "00000001" during run.<br/>Use U1-12 [Drive Status] to monitor the actual MFDO terminal status.</p> <p>bit 0 : During Run<br/>bit 1 : During zero-speed<br/>bit 2 : During reverse<br/>bit 3 : During fault reset signal input<br/>bit 4 : During speed agreement<br/>bit 5 : Drive ready<br/>bit 6 : During minor fault detection<br/>bit 7 : During fault detection</p> | No signal output available |
| U2-14<br>(008D)           | Elapsed Time @ Fault     | <p><b>V/f</b> <b>CL-V/f</b> <b>OLV</b> <b>CLV</b> <b>AOLV</b> <b>OLV/PM</b> <b>AOLV/PM</b> <b>CLV/PM</b> <b>EZOLV</b></p> <p>Shows the cumulative operation time of the drive at the fault that occurred most recently.<br/>Use U4-01 [Cumulative Ope Time] to monitor the actual cumulative operation time.<br/>Unit: 1 h</p>  | No signal output available |
| U2-15<br>(07E0)           | SFS Output @ Fault       | <p><b>V/f</b> <b>CL-V/f</b> <b>OLV</b> <b>CLV</b> <b>AOLV</b> <b>OLV/PM</b> <b>AOLV/PM</b> <b>CLV/PM</b> <b>EZOLV</b></p> <p>Shows the output frequency after soft start at the fault that occurred most recently.<br/>Use U1-16 [SFS Output Frequency] to monitor the actual output frequency after soft start.<br/>Unit: 0.01 Hz</p>  | No signal output available |
| U2-16<br>(07E1)           | q-Axis Current@Fault     | <p><b>V/f</b> <b>CL-V/f</b> <b>OLV</b> <b>CLV</b> <b>AOLV</b> <b>OLV/PM</b> <b>AOLV/PM</b> <b>CLV/PM</b> <b>EZOLV</b></p> <p>Shows the q-axis current of the motor at the fault that occurred most recently.<br/>Use U6-01 [Iq Secondary Current] to monitor the actual q-Axis current of the motor.<br/>Unit: 0.1 %</p>  | No signal output available |
| U2-17<br>(07E2)           | d-Axis Current@Fault     | <p><b>V/f</b> <b>CL-V/f</b> <b>OLV</b> <b>CLV</b> <b>AOLV</b> <b>OLV/PM</b> <b>AOLV/PM</b> <b>CLV/PM</b> <b>EZOLV</b></p> <p>Shows the d-axis current of the motor at the fault that occurred most recently.<br/>Use U6-02 [Id ExcitationCurrent] to monitor the actual d-Axis current of the motor.<br/>Unit: 0.1 %</p>  | No signal output available |
| U2-19<br>(07E4)           | ControlDeviation@Flt     | <p><b>V/f</b> <b>CL-V/f</b> <b>OLV</b> <b>CLV</b> <b>AOLV</b> <b>OLV/PM</b> <b>AOLV/PM</b> <b>CLV/PM</b> <b>EZOLV</b></p> <p>Shows the amount of control axis deviation (<math>\Delta\theta</math>) at the fault that occurred most recently.<br/>Use U6-10 [ContAxisDeviation <math>\Delta\theta</math>] to monitor the actual amount of control axis deviation (<math>\Delta\theta</math>).<br/>Unit: 0.1 °</p>   | No signal output available |
| U2-20<br>(008E)           | Heatsink Temp @Fault     | <p><b>V/f</b> <b>CL-V/f</b> <b>OLV</b> <b>CLV</b> <b>AOLV</b> <b>OLV/PM</b> <b>AOLV/PM</b> <b>CLV/PM</b> <b>EZOLV</b></p> <p>Shows the heatsink temperature at the fault that occurred most recently.<br/>Use U4-08 [Heatsink Temperature] to monitor the actual temperature of the heatsink.<br/>Unit: 1 °C</p>  | No signal output available |
| U2-21<br>(1166)<br>Expert | STPo Detect @ Fault      | <p><b>V/f</b> <b>CL-V/f</b> <b>OLV</b> <b>CLV</b> <b>AOLV</b> <b>OLV/PM</b> <b>AOLV/PM</b> <b>CLV/PM</b> <b>EZOLV</b></p> <p>Monitors conditions to detect STPo [Motor Step-Out Detected] faults. The bit for each condition is displayed as ON or OFF.</p> <p>bit 0 : Excessive current<br/>bit 1 : Induced voltage deviation<br/>bit 2 : d-axis current deviation<br/>bit 3 : Motor lock at startup<br/>bit 4 : Acceleration stall continue<br/>bit 5 : Acceleration stall repeat<br/>bit 6 : Not used (normal value of 0).<br/>bit 7 : Not used (normal value of 0).</p>   | No signal output available |

## ◆ U3: Fault History

| No. (Hex.)                                       | Name                         | Description  | MFAO Signal Level          |
|--|------------------------------|--|----------------------------|
| U3-01 to U3-04<br>(0090 - 0093)<br>(0800 - 0803) | 1st to 4th MostRecent Fault  | <p><b>V/f</b> <b>CL-V/f</b> <b>OLV</b> <b>CLV</b> <b>AOLV</b> <b>OLV/PM</b> <b>AOLV/PM</b> <b>CLV/PM</b> <b>EZOLV</b></p> <p>Shows the fault history of the first to fourth most recent faults.</p> <p><b>Note:</b><br/>The drive saves the U3-01 to U3-04 [1st to 4th MostRecent Fault] fault histories to two types of registers at the same time for the MEMOBUS/Modbus communications.</p> | No signal output available |
| U3-05 to U3-10<br>(0804 - 0809)                  | 5th to 10th MostRecent Fault | <p><b>V/f</b> <b>CL-V/f</b> <b>OLV</b> <b>CLV</b> <b>AOLV</b> <b>OLV/PM</b> <b>AOLV/PM</b> <b>CLV/PM</b> <b>EZOLV</b></p> <p>Shows the fault history of the fifth to tenth most recent faults.</p>   | No signal output available |




| No. (Hex.)                                       | Name                         | Description   | MFAO Signal Level          |
|--|------------------------------|---|----------------------------|
| U3-11 to U3-14<br>(0094 - 0097)<br>(080A - 080D) | ElapsedTime@1st to 4thFault  | <p><b>V/f</b> <b>CL-V/f</b> <b>OLV</b> <b>CLV</b> <b>AOLV</b> <b>OLV/PM</b> <b>AOLV/PM</b> <b>CLV/PM</b> <b>EZOLV</b></p> <p>Shows the cumulative operation time when the first to fourth most recent faults occurred.<br/>Unit: 1 h</p> <p><b>Note:</b><br/>The drive saves the U3-11 to U3-14 [ElapsedTime@1st to 4thFault] the cumulative operation time to two types of registers at the same time for the MEMOBUS/Modbus communications.</p> | No signal output available |
| U3-15 to U3-20<br>(080E - 0813)                  | ElapsedTime@5th to 10thFault | <p><b>V/f</b> <b>CL-V/f</b> <b>OLV</b> <b>CLV</b> <b>AOLV</b> <b>OLV/PM</b> <b>AOLV/PM</b> <b>CLV/PM</b> <b>EZOLV</b></p> <p>Shows the cumulative operation time when the fifth to tenth most recent faults occurred.<br/>Unit: 1 h</p>   | No signal output available |

## ◆ U4: Maintenance Monitors

| No. (Hex.)      | Name                 | Description  | MFAO Signal Level |
|-----------------|----------------------|--|-------------------|
| U4-01<br>(004C) | Cumulative Ope Time  | <p><b>V/f</b> <b>CL-V/f</b> <b>OLV</b> <b>CLV</b> <b>AOLV</b> <b>OLV/PM</b> <b>AOLV/PM</b> <b>CLV/PM</b> <b>EZOLV</b></p> <p>Shows the cumulative operation time of the drive.<br/>Use parameter o4-01 [Elapsed Operating Time Setting] to reset this monitor. Use parameter o4-02 [Elapsed Operating Time Selection] to select the cumulative operation times from:</p> <ul style="list-style-type: none"> <li>The time from when the drive is energized until it is de-energized.</li> <li>The time at which the Run command is turned ON.</li> </ul> <p>The maximum value that the monitor will show is 99999. After this value is more than 99999, the drive automatically resets it and starts to count from 0 again.<br/>Unit: 1 h</p> <p><b>Note:</b><br/>The MEMOBUS/Modbus communication data is shown in 10 h units. Use register 0099H for data in 1 h units.</p> | 10 V: 99999 h     |
| U4-02<br>(0075) | Num of Run Commands  | <p><b>V/f</b> <b>CL-V/f</b> <b>OLV</b> <b>CLV</b> <b>AOLV</b> <b>OLV/PM</b> <b>AOLV/PM</b> <b>CLV/PM</b> <b>EZOLV</b></p> <p>Shows how many times that the drive has received a Run command.<br/>Use parameter o4-13 [RUN Command Counter @ Initialize] to reset this monitor. The maximum value that the monitor will show is 65535. After this value is more than 65535, the drive automatically resets it and starts to count from 0 again.<br/>Unit: 1</p>   | 10 V: 65535 times |
| U4-03<br>(0067) | Cooling Fan Ope Time | <p><b>V/f</b> <b>CL-V/f</b> <b>OLV</b> <b>CLV</b> <b>AOLV</b> <b>OLV/PM</b> <b>AOLV/PM</b> <b>CLV/PM</b> <b>EZOLV</b></p> <p>Shows the cumulative operation time of the cooling fans.<br/>Use parameter o4-03 [Fan Operation Time Setting] to reset this monitor. The maximum value that the monitor will show is 99999. After this value is more than 99999, the drive automatically resets it and starts to count from 0 again.<br/>Unit: 1 h</p> <p><b>Note:</b><br/>The MEMOBUS/Modbus communication data is shown in 10 h units. Use register 009BH for data in 1 h units.</p>  | 10 V: 99999 h     |
| U4-04<br>(007E) | Cool Fan Maintenance | <p><b>V/f</b> <b>CL-V/f</b> <b>OLV</b> <b>CLV</b> <b>AOLV</b> <b>OLV/PM</b> <b>AOLV/PM</b> <b>CLV/PM</b> <b>EZOLV</b></p> <p>Shows the cumulative operation time of the cooling fans as a percentage of the replacement life of the cooling fans.<br/>Use parameter o4-03 [Fan Operation Time Setting] to reset this monitor.<br/>Unit: 1%</p> <p><b>Note:</b><br/>Replace the cooling fans when this monitor is 90%.</p>  | 10 V: 100%        |
| U4-05<br>(007C) | CapacitorMaintenance | <p><b>V/f</b> <b>CL-V/f</b> <b>OLV</b> <b>CLV</b> <b>AOLV</b> <b>OLV/PM</b> <b>AOLV/PM</b> <b>CLV/PM</b> <b>EZOLV</b></p> <p>Shows the operation time of the electrolytic capacitors for the main circuit and control circuit as a percentage of the replacement life of the electrolytic capacitors.<br/>Use parameter o4-05 [Capacitor Maintenance Setting] to reset this monitor.<br/>Unit: 1%</p> <p><b>Note:</b><br/>Replace the electrolytic capacitor when this monitor is 90%.</p>   | 10 V: 100%        |
| U4-06<br>(07D6) | PreChargeRelayMainte | <p><b>V/f</b> <b>CL-V/f</b> <b>OLV</b> <b>CLV</b> <b>AOLV</b> <b>OLV/PM</b> <b>AOLV/PM</b> <b>CLV/PM</b> <b>EZOLV</b></p> <p>Shows the operation time of the soft charge bypass relay as a percentage of the replacement life of the soft charge bypass relay.<br/>Use parameter o4-07 [Softcharge Relay Maintenance Set] to reset this monitor.<br/>Unit: 1%</p> <p><b>Note:</b><br/>Replace the drive when this monitor is 90%.</p>  | 10 V: 100%        |

## 1.17 U: Monitors

| No. (Hex.)      | Name                 | Description   | MFAO Signal Level          |
|-----------------|----------------------|---|----------------------------|
| U4-07<br>(07D7) | IGBT Maintenance     | <p><b>V/f</b> <b>CL-V/f</b> <b>OLV</b> <b>CLV</b> <b>AOLV</b> <b>OLV/PM</b> <b>AOLV/PM</b> <b>CLV/PM</b> <b>EZOLV</b></p> <p>Shows the operation time of the IGBTs as a percentage of the replacement life of the IGBTs. Set parameter <i>o4-09</i> [IGBT Maintenance Setting] to reset this monitor.<br/>Unit: 1%<br/><b>Note:</b><br/>Replace the drive when this monitor is 90%.</p>   | 10 V: 100%                 |
| U4-08<br>(0068) | Heatsink Temperature | <p><b>V/f</b> <b>CL-V/f</b> <b>OLV</b> <b>CLV</b> <b>AOLV</b> <b>OLV/PM</b> <b>AOLV/PM</b> <b>CLV/PM</b> <b>EZOLV</b></p> <p>Shows the heatsink temperature of the drive.<br/>Unit: 1 °C</p>  | 10 V: 100 °C               |
| U4-09<br>(005E) | LED Check            | <p><b>V/f</b> <b>CL-V/f</b> <b>OLV</b> <b>CLV</b> <b>AOLV</b> <b>OLV/PM</b> <b>AOLV/PM</b> <b>CLV/PM</b> <b>EZOLV</b></p> <p>Turns on the LED Status Ring and all of the keypad LEDs to make sure that the LEDs operate correctly.<br/><b>Note:</b><br/>A damaged LED Status Ring board will prevent an accurate estimate of the internal status of the drive. Do not use only the LED Status Ring to estimate the status of the drive and motors.<br/>1. Set <i>o2-24</i> = 0 [LED Light Function Selection = Enable Status Ring &amp; Keypad LED].<br/>2. Push  with <i>U4-09</i> shown on the keypad. All LEDs on the keypad and LED Status Ring will turn on.<br/><b>Note:</b><br/>When Safety input 2 CH is open (STo), READY will flash.</p>   | No signal output available |
| U4-10<br>(005C) | kWh, Lower 4 Digits  | <p><b>V/f</b> <b>CL-V/f</b> <b>OLV</b> <b>CLV</b> <b>AOLV</b> <b>OLV/PM</b> <b>AOLV/PM</b> <b>CLV/PM</b> <b>EZOLV</b></p> <p>Displays the lower 4 digits of the watt hour value for the drive.<br/>Unit: 1 kWh<br/><b>Note:</b><br/>The watt hour is displayed in 9 digits. Monitor <i>U4-11</i> [kWh, Upper 5 Digits] shows the upper 5 digits and <i>U4-10</i> shows the lower 4 digits.<br/>Example for 12345678.9 kWh:<br/><i>U4-10</i>: 678.9 kWh<br/><i>U4-11</i>: 12345 MWh</p>  | No signal output available |
| U4-11<br>(005D) | kWh, Upper 5 Digits  | <p><b>V/f</b> <b>CL-V/f</b> <b>OLV</b> <b>CLV</b> <b>AOLV</b> <b>OLV/PM</b> <b>AOLV/PM</b> <b>CLV/PM</b> <b>EZOLV</b></p> <p>Shows the upper 5 digits of the watt hour value for the drive.<br/>Unit: 1 MWh<br/><b>Note:</b><br/>Monitor <i>U4-11</i> shows the upper 5 digits and <i>U4-10</i> [kWh, Lower 4 Digits] shows the lower 4 digits.<br/>Example for 12345678.9 kWh:<br/><i>U4-10</i>: 678.9 kWh<br/><i>U4-11</i>: 12345 MWh</p>   | No signal output available |
| U4-13<br>(07CF) | Peak Hold Current    | <p><b>V/f</b> <b>CL-V/f</b> <b>OLV</b> <b>CLV</b> <b>AOLV</b> <b>OLV/PM</b> <b>AOLV/PM</b> <b>CLV/PM</b> <b>EZOLV</b></p> <p>Shows the hold value of the peak value (rms) for the drive output current.<br/>Use <i>U4-14</i> [PeakHold Output Freq] to show the drive output frequency at the time that the drive holds the output current.<br/>The drive will hold the peak hold current at the next start up and restart of the power supply.<br/>The drive keeps the held value during baseblock (during stop).<br/>The keypad shows the value of <i>U4-13</i> in amperes (A). When looking at the monitor through MEMOBUS/Modbus communications, the current is "8192 = drive rated current (A)." Calculate the current from the monitor value that is in at MEMOBUS/Modbus communications using "Numerals being displayed / 8192 × drive rated current (A)."<br/>Unit: Determined by the drive model.<br/>• 0.01 A: 2004 to 2042, 4002 to 4023<br/>• 0.1 A: 2056 to 2415, 4031 to 4720</p> | No signal output available |
| U4-14<br>(07D0) | PeakHold Output Freq | <p><b>V/f</b> <b>CL-V/f</b> <b>OLV</b> <b>CLV</b> <b>AOLV</b> <b>OLV/PM</b> <b>AOLV/PM</b> <b>CLV/PM</b> <b>EZOLV</b></p> <p>Displays the output frequency at which the peak value (rms) of the drive output current is held.<br/>The peak hold current can be monitored by <i>U4-13</i> [Peak Hold Current].<br/>The peak hold output frequency will be cleared at the next startup and restart of the power supply.<br/>The drive keeps the value that was under hold during baseblock (during stop).<br/>Unit: 0.01 Hz</p>   | No signal output available |
| U4-16<br>(07D8) | Motor oL1 Level      | <p><b>V/f</b> <b>CL-V/f</b> <b>OLV</b> <b>CLV</b> <b>AOLV</b> <b>OLV/PM</b> <b>AOLV/PM</b> <b>CLV/PM</b> <b>EZOLV</b></p> <p>Shows the integrated value of <i>oL1</i> [Motor Overload] as a percentage of <i>oL1</i> detection level.<br/>Unit: 0.1%</p>  | 10 V: 100%                 |

| No. (Hex.)      | Name                 | Description   | MFAO Signal Level  |
|-----------------|----------------------|---|--|
| U4-18<br>(07DA) | Reference Source     | <p><b>V/f</b> <b>CL-V/f</b> <b>OLV</b> <b>CLV</b> <b>AOLV</b> <b>OLV/PM</b> <b>AOLV/PM</b> <b>CLV/PM</b> <b>EZOLV</b></p> <p>Shows the selected frequency reference source.<br/>The keypad shows the frequency reference source as "XY-nn" as specified by these rules:<br/>X: <i>External Reference 1/2 Selection [H1-xx = 2]</i> selection status</p> <ul style="list-style-type: none"> <li>• 1: <i>b1-01 [Frequency Reference Selection 1]</i></li> <li>• 2: <i>b1-15 [Frequency Reference Selection 2]</i></li> </ul> <p>Y-nn: Frequency reference source</p> <ul style="list-style-type: none"> <li>• 0-01: Keypad (<i>d1-01 [Reference 1]</i>)</li> <li>• 1-00: Analog input (unassigned)</li> <li>• 1-01: MFAI terminal A1</li> <li>• 1-02: MFAI terminal A2</li> <li>• 1-03: MFAI terminal A3</li> <li>• 2-02 to 2-17: Multi-step speed reference (<i>d1-02 to d1-17 [Reference 2 to 16, Jog Reference]</i>)</li> <li>• 3-01: MEMOBUS/Modbus communications</li> <li>• 4-01: Communication option card</li> <li>• 5-01: Pulse train input</li> <li>• 7-01: DriveWorksEZ</li> <li>• 9-01: Up/Down command</li> </ul>  | No signal output available   |
| U4-19<br>(07DB) | Modbus FreqRef (dec) | <p><b>V/f</b> <b>CL-V/f</b> <b>OLV</b> <b>CLV</b> <b>AOLV</b> <b>OLV/PM</b> <b>AOLV/PM</b> <b>CLV/PM</b> <b>EZOLV</b></p> <p>Shows the frequency reference sent to the drive from the MEMOBUS/Modbus communications as a decimal.<br/>Unit: 0.01%</p>   | 10 V = Maximum frequency (-10 V to +10 V)  |
| U4-20<br>(07DC) | Option Freq Ref(dec) | <p><b>V/f</b> <b>CL-V/f</b> <b>OLV</b> <b>CLV</b> <b>AOLV</b> <b>OLV/PM</b> <b>AOLV/PM</b> <b>CLV/PM</b> <b>EZOLV</b></p> <p>Shows the frequency reference sent to the drive from the communication option as a decimal.</p>  | 10 V = Maximum frequency (-10 V to +10 V)  |
| U4-21<br>(07DD) | Run Command Source   | <p><b>V/f</b> <b>CL-V/f</b> <b>OLV</b> <b>CLV</b> <b>AOLV</b> <b>OLV/PM</b> <b>AOLV/PM</b> <b>CLV/PM</b> <b>EZOLV</b></p> <p>Shows the selected Run command source.<br/>The keypad shows the Run command source as "XY-nn" as specified by these rules:<br/>X: <i>External Reference 1/2 Selection [H1-xx = 2]</i> selection status</p> <ul style="list-style-type: none"> <li>• 1: <i>b1-02 [Run Command Selection 1]</i></li> <li>• 2: <i>b1-16 [Run Command Selection 2]</i></li> </ul> <p>Y: Run command source</p> <ul style="list-style-type: none"> <li>• 0: Keypad</li> <li>• 1: Control circuit terminal</li> <li>• 3: MEMOBUS/Modbus communications</li> <li>• 4: Communication option card</li> <li>• 7: DriveWorksEZ</li> </ul> <p>nn: Run command limit status data</p> <ul style="list-style-type: none"> <li>• 00: No limit status.</li> <li>• 01: The Run command was left ON when the drive stopped in the Programming Mode.</li> <li>• 02: The Run command was left ON when switching from LOCAL Mode to REMOTE Mode.</li> <li>• 03: The Run command is in standby after the drive was energized until the soft charge bypass contactor turns ON.</li> </ul> <p><b>Note:</b><br/>The drive will detect <i>Uv1 [DC Bus Undervoltage]</i> or <i>Uv [Undervoltage]</i> if the soft charge bypass contactor does not turn ON after 10 s.</p> <ul style="list-style-type: none"> <li>• 04: Restart after run stop is prohibited.</li> <li>• 05: Fast stop has been executed using the MFDI terminal. Or, the motor has ramped to stop by pressing the STOP key on the keypad.</li> <li>• 06: <i>b1-17 = 0 [Run Command at Power Up = Disregard Existing RUN Command]</i> is set.</li> <li>• 07: During baseblock while coast to stop with timer.</li> <li>• 08: Frequency reference is below <i>E1-09 [Minimum Output Frequency]</i> during baseblock.</li> <li>• 09: Waiting for the Enter command from PLC.</li> </ul> | No signal output The keypad shows the Run command source as "XY-nn" as specified by these rules: available |

## 1.17 U: Monitors

| No. (Hex.)      | Name                 | Description  | MFAO Signal Level            |
|-----------------|----------------------|--|------------------------------|
| U4-22<br>(07DE) | Modbus CmdData (hex) | <p><b>V/f</b> <b>CL-V/f</b> <b>OLV</b> <b>CLV</b> <b>AOLV</b> <b>OLV/PM</b> <b>AOLV/PM</b> <b>CLV/PM</b> <b>EZOLV</b></p> <p>Shows the operation signal (register 0001H) sent to the drive from MEMOBUS/Modbus communications as a 4-digit hexadecimal number (zero suppress). The keypad shows the operation signal as specified by these rules:</p> <p>bit 0 : Forward run/Stop<br/> bit 1 : Reverse run/Stop<br/> bit 2 : External fault<br/> bit 3 : Fault Reset<br/> bit 4 : Multi-function input 1<br/> bit 5 : Multi-function input 2<br/> bit 6 : Multi-function input 3<br/> bit 7 : Multi-function input 4<br/> bit 8 : Multi-function input 5<br/> bit 9 : Multi-function input 6<br/> bit A : Multi-function input 7<br/> bit B : Multi-function input 8<br/> bit C : Not used (normal value of 0).<br/> bit D : Not used (normal value of 0).<br/> bit E : Not used (normal value of 0).<br/> bit F : Not used (normal value of 0).</p> | No signal output available   |
| U4-23<br>(07DF) | Option CmdData (hex) | <p><b>V/f</b> <b>CL-V/f</b> <b>OLV</b> <b>CLV</b> <b>AOLV</b> <b>OLV/PM</b> <b>AOLV/PM</b> <b>CLV/PM</b> <b>EZOLV</b></p> <p>Shows the operation signal (register 0001H) sent to the drive from MEMOBUS/Modbus communications as a 4-digit hexadecimal number. The keypad shows the operation signal as specified by these rules:</p> <p>bit 0 : Forward run/Stop<br/> bit 1 : Reverse run/Stop<br/> bit 2 : External fault<br/> bit 3 : Fault Reset<br/> bit 4 : Multi-function input 1<br/> bit 5 : Multi-function input 2<br/> bit 6 : Multi-function input 3<br/> bit 7 : Multi-function input 4<br/> bit 8 : Multi-function input 5<br/> bit 9 : Multi-function input 6<br/> bit A : Multi-function input 7<br/> bit B : Multi-function input 8<br/> bit C : Not used (normal value of 0).<br/> bit D : Not used (normal value of 0).<br/> bit E : Not used (normal value of 0).<br/> bit F : Not used (normal value of 0).</p>                 | No signal output available   |
| U4-24<br>(07E6) | Number of Runs (Low) | <p><b>V/f</b> <b>CL-V/f</b> <b>OLV</b> <b>CLV</b> <b>AOLV</b> <b>OLV/PM</b> <b>AOLV/PM</b> <b>CLV/PM</b> <b>EZOLV</b></p> <p>Shows the lower 4 digits of the drive run count.</p> <p><b>Note:</b><br/> The drive run count appears as an 8-digit number. Monitor <i>U4-25 [Number of Runs(High)]</i> shows the upper 4 digits and <i>U4-24</i> shows the lower 4 digits.</p>   | No signal output available   |
| U4-25<br>(07E7) | Number of Runs(High) | <p><b>V/f</b> <b>CL-V/f</b> <b>OLV</b> <b>CLV</b> <b>AOLV</b> <b>OLV/PM</b> <b>AOLV/PM</b> <b>CLV/PM</b> <b>EZOLV</b></p> <p>Shows the lower 4 digits of the drive run count.</p> <p><b>Note:</b><br/> The drive run count appears as an 8-digit number. Monitor <i>U4-25</i> shows the upper 4 digits and <i>U4-24 [Number of Runs (Low)]</i> shows the lower 4 digits.</p>   | No signal output available   |
| U4-52<br>(1592) | Torque Ref from Comm | <p><b>V/f</b> <b>CL-V/f</b> <b>OLV</b> <b>CLV</b> <b>AOLV</b> <b>OLV/PM</b> <b>AOLV/PM</b> <b>CLV/PM</b> <b>EZOLV</b></p> <p>Displays the torque reference given to the drive via a serial communication option card or via MEMOBUS/Modbus communications as a decimal number.</p> <p>Unit: 0.1%</p>   | 10 V = 100% (-10 V to +10 V) |

## ◆ U5: PID Monitors

| No. (Hex.)                | Name                   | Description  | MFAO Signal Level                            |
|---------------------------|------------------------|--|--|
| U5-01<br>(0057)           | PID Feedback           | <b>V/f</b> <b>CL-V/f</b> <b>OLV</b> <b>CLV</b> <b>AOLV</b> <b>OLV/PM</b> <b>AOLV/PM</b> <b>CLV/PM</b> <b>EZOLV</b><br>Shows the PID control feedback value. Parameter <i>b5-20 [PID Unit Selection]</i> sets the display units.<br>Unit: 0.01%   | 10 V = Maximum frequency<br>(-10 V to +10 V) |
| U5-02<br>(0063)           | PID Input              | <b>V/f</b> <b>CL-V/f</b> <b>OLV</b> <b>CLV</b> <b>AOLV</b> <b>OLV/PM</b> <b>AOLV/PM</b> <b>CLV/PM</b> <b>EZOLV</b><br>Shows the change between the PID setpoint and PID feedback (the quantity of PID input) as a percentage of the maximum output frequency.<br>Unit: 0.01%   | 10 V = Maximum frequency<br>(-10 V to +10 V) |
| U5-03<br>(0064)           | PID Output             | <b>V/f</b> <b>CL-V/f</b> <b>OLV</b> <b>CLV</b> <b>AOLV</b> <b>OLV/PM</b> <b>AOLV/PM</b> <b>CLV/PM</b> <b>EZOLV</b><br>Shows the PID control output as a percentage of the maximum output frequency.<br>Unit: 0.01%   | 10 V = Maximum frequency<br>(-10 V to +10 V) |
| U5-04<br>(0065)           | PID Setpoint           | <b>V/f</b> <b>CL-V/f</b> <b>OLV</b> <b>CLV</b> <b>AOLV</b> <b>OLV/PM</b> <b>AOLV/PM</b> <b>CLV/PM</b> <b>EZOLV</b><br>Shows the PID setpoint. Parameter <i>b5-20 [PID Unit Selection]</i> sets the display units.<br>Unit: 0.01%   | 10 V = Maximum frequency<br>(-10 V to +10 V) |
| U5-05<br>(07D2)           | PID DifferentialFdbk   | <b>V/f</b> <b>CL-V/f</b> <b>OLV</b> <b>CLV</b> <b>AOLV</b> <b>OLV/PM</b> <b>AOLV/PM</b> <b>CLV/PM</b> <b>EZOLV</b><br>Shows the PID differential feedback value as a percentage of the maximum output frequency.<br>This monitor is available after you set <i>H3-02, H3-10, or H3-06 = 16 [MFAI Function Selection = Differential PID Feedback]</i> .<br>Unit: 0.01%                            | 10 V = Maximum frequency<br>(-10 V to +10 V) |
| U5-06<br>(07D3)           | PID Fdbk-Diff PID Fdbk | <b>V/f</b> <b>CL-V/f</b> <b>OLV</b> <b>CLV</b> <b>AOLV</b> <b>OLV/PM</b> <b>AOLV/PM</b> <b>CLV/PM</b> <b>EZOLV</b><br>Shows the difference from calculating <i>U5-05 - U5-01 [PID DifferentialFdbk] - [PID Feedback]</i> .<br>Unit: 0.01%<br><b>Note:</b><br><i>U5-01 [PID Feedback] = U5-06</i> when <i>H3-02, H3-10, or H3-06 ≠ 16 [MFAI Function Selection ≠ Differential PID Feedback]</i> . | 10 V = Maximum frequency<br>(-10 V to +10 V) |
| U5-21<br>(0872)<br>Expert | Energy Save Coeff Ki   | <b>V/f</b> <b>CL-V/f</b> <b>OLV</b> <b>CLV</b> <b>AOLV</b> <b>OLV/PM</b> <b>AOLV/PM</b> <b>CLV/PM</b> <b>EZOLV</b><br>Shows the energy-saving coefficient Ki value for PM.<br>Unit: 0.01   | No signal output available                   |
| U5-22<br>(0873)<br>Expert | Energy Save Coeff Kt   | <b>V/f</b> <b>CL-V/f</b> <b>OLV</b> <b>CLV</b> <b>AOLV</b> <b>OLV/PM</b> <b>AOLV/PM</b> <b>CLV/PM</b> <b>EZOLV</b><br>Shows the energy-saving coefficient Kt value for PM.<br>Unit: 0.01   | No signal output available                   |
| U5-99<br>(1599)           | PID Setpoint Command   | <b>V/f</b> <b>CL-V/f</b> <b>OLV</b> <b>CLV</b> <b>AOLV</b> <b>OLV/PM</b> <b>AOLV/PM</b> <b>CLV/PM</b> <b>EZOLV</b><br>Shows the PID setpoint command. Parameter <i>b5-20 [PID Unit Selection]</i> sets the display units.<br>Unit: 0.01%   | 10 V = Maximum frequency<br>(-10 V to +10 V) |

## ◆ U6: Operation Status Monitors

| No. (Hex.)      | Name                 | Description  | MFAO Signal Level  |
|-----------------|----------------------|--|--|
| U6-01<br>(0051) | Iq Secondary Current | <b>V/f</b> <b>CL-V/f</b> <b>OLV</b> <b>CLV</b> <b>AOLV</b> <b>OLV/PM</b> <b>AOLV/PM</b> <b>CLV/PM</b> <b>EZOLV</b><br>Shows the value calculated for the motor secondary current (q axis) as a percentage of the motor rated secondary current.<br>Unit: 0.1%  | 10 V = Motor secondary rated current<br>(-10 V to +10 V)                         |
| U6-02<br>(0052) | Id ExcitationCurrent | <b>V/f</b> <b>CL-V/f</b> <b>OLV</b> <b>CLV</b> <b>AOLV</b> <b>OLV/PM</b> <b>AOLV/PM</b> <b>CLV/PM</b> <b>EZOLV</b><br>Shows the value calculated for the motor excitation current (d axis) as a percentage of the motor rated secondary current.<br>Unit: 0.1% | 10 V = Motor secondary rated current<br>(-10 V to +10 V)                         |
| U6-03<br>(0054) | ASR Input            | <b>V/f</b> <b>CL-V/f</b> <b>OLV</b> <b>CLV</b> <b>AOLV</b> <b>OLV/PM</b> <b>AOLV/PM</b> <b>CLV/PM</b> <b>EZOLV</b><br>Shows the ASR input value as a percentage of the maximum frequency.<br>Unit: 0.01%   | 10 V = Maximum frequency<br>(-10 V to +10 V)                                     |
| U6-04<br>(0055) | ASR Output           | <b>V/f</b> <b>CL-V/f</b> <b>OLV</b> <b>CLV</b> <b>AOLV</b> <b>OLV/PM</b> <b>AOLV/PM</b> <b>CLV/PM</b> <b>EZOLV</b><br>Shows the ASR output value as a percentage of the motor rated secondary current.<br>Unit: 0.01%  | 10 V = Motor secondary rated current<br>(-10 V to +10 V)                         |
| U6-05<br>(0059) | OutputVoltageRef: Vq | <b>V/f</b> <b>CL-V/f</b> <b>OLV</b> <b>CLV</b> <b>AOLV</b> <b>OLV/PM</b> <b>AOLV/PM</b> <b>CLV/PM</b> <b>EZOLV</b><br>Shows the drive internal voltage reference for motor secondary current control (q axis).<br>Unit: 0.1 V                                  | 200 V class: 10 V = 200 Vrms<br>400 V class: 10 V = 400 Vrms<br>(-10 V to +10 V) |

## 1.17 U: Monitors

| No. (Hex.)                | Name                 | Description   | MFAO Signal Level  |
|---------------------------|----------------------|---|--|
| U6-06<br>(005A)           | OutputVoltageRef: Vd | <input type="checkbox"/> V/f <input type="checkbox"/> CL-V/f <input type="checkbox"/> OLV <input type="checkbox"/> CLV <input type="checkbox"/> AOLV <input type="checkbox"/> OLV/PM <input type="checkbox"/> AOLV/PM <input type="checkbox"/> CLV/PM <input type="checkbox"/> EZOLV<br>Shows the drive internal voltage reference for motor excitation current control (d axis).<br>Unit: 0.1 V  | 200 V class: 10 V = 200 Vrms<br>400 V class: 10 V = 400 Vrms<br>(-10 V to +10 V) |
| U6-07<br>(005F)<br>Expert | q-Axis ACR Output    | <input type="checkbox"/> V/f <input type="checkbox"/> CL-V/f <input type="checkbox"/> OLV <input type="checkbox"/> CLV <input type="checkbox"/> AOLV <input type="checkbox"/> OLV/PM <input type="checkbox"/> AOLV/PM <input type="checkbox"/> CLV/PM <input type="checkbox"/> EZOLV<br>Shows the output value for current control related to motor secondary current (q axis).<br>Unit: 0.1%   | 200 V class: 10 V = 200 Vrms<br>400 V class: 10 V = 400 Vrms<br>(-10 V to +10 V) |
| U6-08<br>(0060)<br>Expert | d-Axis ACR Output    | <input type="checkbox"/> V/f <input type="checkbox"/> CL-V/f <input type="checkbox"/> OLV <input type="checkbox"/> CLV <input type="checkbox"/> AOLV <input type="checkbox"/> OLV/PM <input type="checkbox"/> AOLV/PM <input type="checkbox"/> CLV/PM <input type="checkbox"/> EZOLV<br>Shows the output value for current control related to motor excitation current (d axis).<br>Unit: 0.1%  | 200 V class: 10 V = 200 Vrms<br>400 V class: 10 V = 400 Vrms<br>(-10 V to +10 V) |
| U6-09<br>(07C0)<br>Expert | AdvPhase Compen Δθ   | <input type="checkbox"/> V/f <input type="checkbox"/> CL-V/f <input type="checkbox"/> OLV <input type="checkbox"/> CLV <input type="checkbox"/> AOLV <input type="checkbox"/> OLV/PM <input type="checkbox"/> AOLV/PM <input type="checkbox"/> CLV/PM <input type="checkbox"/> EZOLV<br>Displays the data on forward phase compensation for the calculation results of the amount of control axis deviation.<br>Unit: 1 °   | 10 V: 180° (-10 V to +10 V)  |
| U6-10<br>(07C1)<br>Expert | ContAxisDeviation Δθ | <input type="checkbox"/> V/f <input type="checkbox"/> CL-V/f <input type="checkbox"/> OLV <input type="checkbox"/> CLV <input type="checkbox"/> AOLV <input type="checkbox"/> OLV/PM <input type="checkbox"/> AOLV/PM <input type="checkbox"/> CLV/PM <input type="checkbox"/> EZOLV<br>Shows the deviation between the γδ-Axis used for motor control and the dq-Axis.<br>Unit: 0.1 °  | 10 V: 180° (-10 V to +10 V)  |
| U6-13<br>(07CA)<br>Expert | MagPolePosition(Enc) | <input type="checkbox"/> V/f <input type="checkbox"/> CL-V/f <input type="checkbox"/> OLV <input type="checkbox"/> CLV <input type="checkbox"/> AOLV <input type="checkbox"/> OLV/PM <input type="checkbox"/> AOLV/PM <input type="checkbox"/> CLV/PM <input type="checkbox"/> EZOLV<br>Shows the value of the flux position detection.<br>Unit: 0.1 °  | 10 V: 180° (-10 V to +10 V)  |
| U6-14<br>(07CB)<br>Expert | MagPolePosition(Obs) | <input type="checkbox"/> V/f <input type="checkbox"/> CL-V/f <input type="checkbox"/> OLV <input type="checkbox"/> CLV <input type="checkbox"/> AOLV <input type="checkbox"/> OLV/PM <input type="checkbox"/> AOLV/PM <input type="checkbox"/> CLV/PM <input type="checkbox"/> EZOLV<br>Shows the value of the flux position estimation.<br>Unit: 0.1 °   | 10 V: 180° (-10 V to +10 V)  |
| U6-17<br>(07D1)<br>Expert | Energy Save Coeff    | <input type="checkbox"/> V/f <input type="checkbox"/> CL-V/f <input type="checkbox"/> OLV <input type="checkbox"/> CLV <input type="checkbox"/> AOLV <input type="checkbox"/> OLV/PM <input type="checkbox"/> AOLV/PM <input type="checkbox"/> CLV/PM <input type="checkbox"/> EZOLV<br>Shows the total time of direction of motor rotation detections for Speed Estimation Speed Searches. This value adjusts b3-26 [Direction Determination Level].<br><b>Note:</b><br>Upper limit is +32767 and lower limit is -32767. | No signal output available   |
| U6-18<br>(07CD)           | Enc 1 Pulse Counter  | <input type="checkbox"/> V/f <input type="checkbox"/> CL-V/f <input type="checkbox"/> OLV <input type="checkbox"/> CLV <input type="checkbox"/> AOLV <input type="checkbox"/> OLV/PM <input type="checkbox"/> AOLV/PM <input type="checkbox"/> CLV/PM <input type="checkbox"/> EZOLV<br>Shows the number of pulses for speed detection (PG1).<br>Unit: 1 pulse  | 10 V: 65536  |
| U6-19<br>(07E5)           | Enc 2 Pulse Counter  | <input type="checkbox"/> V/f <input type="checkbox"/> CL-V/f <input type="checkbox"/> OLV <input type="checkbox"/> CLV <input type="checkbox"/> AOLV <input type="checkbox"/> OLV/PM <input type="checkbox"/> AOLV/PM <input type="checkbox"/> CLV/PM <input type="checkbox"/> EZOLV<br>Shows the number of pulses for speed detection (PG2).<br>Unit: 1 pulse  | 10 V: 65536  |
| U6-20<br>(07D4)           | UP/DOWN 2 Bias Value | <input type="checkbox"/> V/f <input type="checkbox"/> CL-V/f <input type="checkbox"/> OLV <input type="checkbox"/> CLV <input type="checkbox"/> AOLV <input type="checkbox"/> OLV/PM <input type="checkbox"/> AOLV/PM <input type="checkbox"/> CLV/PM <input type="checkbox"/> EZOLV<br>Shows the bias value used to adjust the frequency reference.<br>Unit: 0.1%  | 10 V: Maximum Frequency  |
| U6-21<br>(07D5)           | Offset Frequency     | <input type="checkbox"/> V/f <input type="checkbox"/> CL-V/f <input type="checkbox"/> OLV <input type="checkbox"/> CLV <input type="checkbox"/> AOLV <input type="checkbox"/> OLV/PM <input type="checkbox"/> AOLV/PM <input type="checkbox"/> CLV/PM <input type="checkbox"/> EZOLV<br>Shows the total value of d7-01 to d7-03 [Offset Frequency 1 to 3] selected with Add Offset Frequency 1 to 3 [HI-xx = 44 to 46].<br>Unit: 0.1%   | 10 V: Maximum Frequency  |
| U6-22<br>(0062)           | ZeroServo Pulse Move | <input type="checkbox"/> V/f <input type="checkbox"/> CL-V/f <input type="checkbox"/> OLV <input type="checkbox"/> CLV <input type="checkbox"/> AOLV <input type="checkbox"/> OLV/PM <input type="checkbox"/> AOLV/PM <input type="checkbox"/> CLV/PM <input type="checkbox"/> EZOLV<br>Shows the distance that the rotor moved from its last position when Zero Servo is available. The value shown in this monitor = 4 X [No. of PG pulses].<br>Unit: 1 pulse   | 10 V = Number of pulses per revolution (-10 V to +10 V)                          |
| U6-25<br>(006B)<br>Expert | ASR Output Level     | <input type="checkbox"/> V/f <input type="checkbox"/> CL-V/f <input type="checkbox"/> OLV <input type="checkbox"/> CLV <input type="checkbox"/> AOLV <input type="checkbox"/> OLV/PM <input type="checkbox"/> AOLV/PM <input type="checkbox"/> CLV/PM <input type="checkbox"/> EZOLV<br>Shows the primary delay filter input value of the ASR (speed control loop).<br>Unit: 0.01%  | 10 V = Motor secondary rated current (-10 V to +10 V)                            |
| U6-26<br>(006C)<br>Expert | Feed Fwd Cont Output | <input type="checkbox"/> V/f <input type="checkbox"/> CL-V/f <input type="checkbox"/> OLV <input type="checkbox"/> CLV <input type="checkbox"/> AOLV <input type="checkbox"/> OLV/PM <input type="checkbox"/> AOLV/PM <input type="checkbox"/> CLV/PM <input type="checkbox"/> EZOLV<br>Shows the Feed Forward control output.<br>Unit: 0.01%   | 10 V = Motor secondary rated current (-10 V to +10 V)                            |
| U6-27<br>(006D)<br>Expert | FeedFwd Estimate Spd | <input type="checkbox"/> V/f <input type="checkbox"/> CL-V/f <input type="checkbox"/> OLV <input type="checkbox"/> CLV <input type="checkbox"/> AOLV <input type="checkbox"/> OLV/PM <input type="checkbox"/> AOLV/PM <input type="checkbox"/> CLV/PM <input type="checkbox"/> EZOLV<br>Shows the feed forward estimated speed.<br>Unit: 0.01%  | 10 V = Maximum frequency (-10 V to +10 V)  |

| No. (Hex.)                              | Name                     | Description   | MFAO Signal Level          |
|---|--------------------------|---|----------------------------|
| U6-31 (007B)                            | TorqueDetect Monitor     | <b>V/f</b> <b>CL-V/f</b> <b>OLV</b> <b>CLV</b> <b>AOLV</b> <b>OLV/PM</b> <b>AOLV/PM</b> <b>CLV/PM</b> <b>EZOLV</b><br>Monitors the torque reference or the output current after applying the filter set to L6-07 [Torque Detection Filter Time].<br>Unit: 0.1%  | 10 V:100%                  |
| U6-36 (0720) Expert                     | Comm Errors-Host         | <b>V/f</b> <b>CL-V/f</b> <b>OLV</b> <b>CLV</b> <b>AOLV</b> <b>OLV/PM</b> <b>AOLV/PM</b> <b>CLV/PM</b> <b>EZOLV</b><br>Shows the number of inter-CPU communication errors. De-energizing the drive sets this number to 0.  | No signal output available |
| U6-37 (0721) Expert                     | Comm Errors-Sensor       | <b>V/f</b> <b>CL-V/f</b> <b>OLV</b> <b>CLV</b> <b>AOLV</b> <b>OLV/PM</b> <b>AOLV/PM</b> <b>CLV/PM</b> <b>EZOLV</b><br>Shows the number of inter-CPU communication errors. De-energizing the drive sets this number to 0.  | No signal output available |
| U6-48 (072E) Expert                     | ASIC Comm Errors         | <b>V/f</b> <b>CL-V/f</b> <b>OLV</b> <b>CLV</b> <b>AOLV</b> <b>OLV/PM</b> <b>AOLV/PM</b> <b>CLV/PM</b> <b>EZOLV</b><br>Counts the number of inter-ASIC communication errors detected by the ASIC. This count is reset to 0 when the power to the drive is turned off.  | No signal output available |
| U6-57 (07C4)                            | PolePolarityDeterVal     | <b>V/f</b> <b>CL-V/f</b> <b>OLV</b> <b>CLV</b> <b>AOLV</b> <b>OLV/PM</b> <b>AOLV/PM</b> <b>CLV/PM</b> <b>EZOLV</b><br>Shows the change from the integrated current when finding the polarity.<br>Unit: 1<br><b>Note:</b><br>If the change from the integrated current is less than 819, increase n8-84 [Polarity Detection Current]. U6-57 = 8192 is equivalent to the motor rated current. | No signal output available |
| U6-80 to U6-83 (07B0 - 07B3)            | Option IP Address 1 to 4 | <b>V/f</b> <b>CL-V/f</b> <b>OLV</b> <b>CLV</b> <b>AOLV</b> <b>OLV/PM</b> <b>AOLV/PM</b> <b>CLV/PM</b> <b>EZOLV</b><br>Shows the currently available local IP Address.<br>• U6-80: 1st octet<br>• U6-81: 2nd octet<br>• U6-82: 3rd octet<br>• U6-83: 4th octet   | No signal output available |
| U6-84 to U6-87 (07B4 - 07B7)            | Online Subnets 1 to 4    | <b>V/f</b> <b>CL-V/f</b> <b>OLV</b> <b>CLV</b> <b>AOLV</b> <b>OLV/PM</b> <b>AOLV/PM</b> <b>CLV/PM</b> <b>EZOLV</b><br>Shows the currently available subnet mask.<br>• U6-84: 1st octet<br>• U6-85: 2nd octet<br>• U6-86: 3rd octet<br>• U6-87: 4th octet  | No signal output available |
| U6-88 to U6-91 (07B8, 07B9, 07F0, 07F1) | Online Gateways 1 to 4   | <b>V/f</b> <b>CL-V/f</b> <b>OLV</b> <b>CLV</b> <b>AOLV</b> <b>OLV/PM</b> <b>AOLV/PM</b> <b>CLV/PM</b> <b>EZOLV</b><br>Shows the currently available gateway address.<br>• U6-88: 1st octet<br>• U6-89: 2nd octet<br>• U6-90: 3rd octet<br>• U6-91: 4th octet  | No signal output available |
| U6-92 (07F2)                            | Online Speed             | <b>V/f</b> <b>CL-V/f</b> <b>OLV</b> <b>CLV</b> <b>AOLV</b> <b>OLV/PM</b> <b>AOLV/PM</b> <b>CLV/PM</b> <b>EZOLV</b><br>Shows the currently available communications speed.<br>10: 10 Mbps<br>100: 100 Mbps   | No signal output available |
| U6-93 (07F3)                            | Online Duplex            | <b>V/f</b> <b>CL-V/f</b> <b>OLV</b> <b>CLV</b> <b>AOLV</b> <b>OLV/PM</b> <b>AOLV/PM</b> <b>CLV/PM</b> <b>EZOLV</b><br>Shows the currently available Duplex setting.   | No signal output available |
| U6-98 (07F8)                            | First Fault              | <b>V/f</b> <b>CL-V/f</b> <b>OLV</b> <b>CLV</b> <b>AOLV</b> <b>OLV/PM</b> <b>AOLV/PM</b> <b>CLV/PM</b> <b>EZOLV</b><br>Shows the contents of the most recent communication options fault (DeviceNet, Modbus TCP/IP, EtherNet/IP).  | No signal output available |
| U6-99 (07F9)                            | Current Fault            | <b>V/f</b> <b>CL-V/f</b> <b>OLV</b> <b>CLV</b> <b>AOLV</b> <b>OLV/PM</b> <b>AOLV/PM</b> <b>CLV/PM</b> <b>EZOLV</b><br>Shows the contents of current fault from communication options (DeviceNet, Modbus TCP/IP, EtherNet/IP).   | No signal output available |

◆ U8: DriveWorksEZ Monitors

| No.<br>(Hex.)                   | Name                   | Description   | MFAO Signal Level          |
|---------------------------------|------------------------|---|----------------------------|
| U8-01 to U8-10<br>(1950 - 1959) | DWEZ Monitors 1 to 10  | <b>V/f</b> <b>CL-V/f</b> <b>OLV</b> <b>CLV</b> <b>AOLV</b> <b>OLV/PM</b> <b>AOLV/PM</b> <b>CLV/PM</b> <b>EZOLV</b><br>Shows DriveWorks EZ Monitors 1 to 10.<br>Unit: 0.01%  | 10 V = 100%                |
| U8-11<br>(195A)                 | DWEZ Version 1         | <b>V/f</b> <b>CL-V/f</b> <b>OLV</b> <b>CLV</b> <b>AOLV</b> <b>OLV/PM</b> <b>AOLV/PM</b> <b>CLV/PM</b> <b>EZOLV</b><br>Displays the upper three digits of the user ID. When you open the setting screen by clicking the setting button on the PC tool title bar, the user ID can be confirmed with the ID display of the primary user. | No signal output available |
| U8-12<br>(195B)                 | DWEZ Version 2         | <b>V/f</b> <b>CL-V/f</b> <b>OLV</b> <b>CLV</b> <b>AOLV</b> <b>OLV/PM</b> <b>AOLV/PM</b> <b>CLV/PM</b> <b>EZOLV</b><br>Displays the lower five digits of the user ID. When you open the setting screen by clicking the setting button on the PC tool title bar, the user ID can be confirmed with the ID display of the primary user.  | No signal output available |
| U8-13<br>(195C)                 | DWEZ Version 3         | <b>V/f</b> <b>CL-V/f</b> <b>OLV</b> <b>CLV</b> <b>AOLV</b> <b>OLV/PM</b> <b>AOLV/PM</b> <b>CLV/PM</b> <b>EZOLV</b><br>Displays the software ID.   | No signal output available |
| U8-18<br>(1961)                 | DWEZ Platform Ver      | <b>V/f</b> <b>CL-V/f</b> <b>OLV</b> <b>CLV</b> <b>AOLV</b> <b>OLV/PM</b> <b>AOLV/PM</b> <b>CLV/PM</b> <b>EZOLV</b><br>Shows the DriveWorksEZ platform version.  | No signal output available |
| U8-21 to U8-25<br>(1964 - 1968) | DWEZ Monitors 21 to 25 | <b>V/f</b> <b>CL-V/f</b> <b>OLV</b> <b>CLV</b> <b>AOLV</b> <b>OLV/PM</b> <b>AOLV/PM</b> <b>CLV/PM</b> <b>EZOLV</b><br>Shows DriveWorks EZ Monitors 21 to 25.<br>Unit: 0.01%   | 10 V = 100%                |
| U8-31 to U8-40<br>(196E - 1977) | DWEZ Monitors 31 to 40 | <b>V/f</b> <b>CL-V/f</b> <b>OLV</b> <b>CLV</b> <b>AOLV</b> <b>OLV/PM</b> <b>AOLV/PM</b> <b>CLV/PM</b> <b>EZOLV</b><br>Shows DriveWorks EZ Monitors 31 to 40.<br>Unit: 0.01%   | 10 V = 100%                |
| U8-51 to U8-55<br>(1982 - 1986) | DWEZ Monitors 51 to 55 | <b>V/f</b> <b>CL-V/f</b> <b>OLV</b> <b>CLV</b> <b>AOLV</b> <b>OLV/PM</b> <b>AOLV/PM</b> <b>CLV/PM</b> <b>EZOLV</b><br>Shows DriveWorks EZ Monitors 51 to 55.<br>Unit: 0.01%   | 10 V = 100%                |



## 1.18 Parameters that Change from the Default Settings with A1-02 [Control Method Selection]

The values for the parameters in these tables depend on the values for parameter A1-02. Changing the setting for A1-02 will change the default settings.

### ◆ A1-02 = 0 to 4 [Induction Motor Control Methods]

| No.   | Name                                 | Range          | Unit    | Control Method (A1-02 Setting) |               |            |            |             |
|-------|--------------------------------------|----------------|---------|--------------------------------|---------------|------------|------------|-------------|
|       |                                      |                |         | V/f<br>(0)                     | CL-V/f<br>(1) | OLV<br>(2) | CLV<br>(3) | AOLV<br>(4) |
| b2-01 | DC Injection/Zero SpeedThreshold     | 0.0 - 10.0     | 0.1 Hz  | 0.5                            | 0.5           | 0.5        | 0.5        | 0.5         |
| b2-04 | DC Inject Braking Time at Stop       | 0.00 - 10.00   | 0.01 s  | 0.50                           | 0.50          | 0.50       | 0.50       | 0.50        |
| b3-01 | Speed Search at Start Selection      | 0 - 1          | 1       | 0                              | 1             | 0          | -          | 0           |
| b3-02 | SpeedSearch Deactivation Current     | 0 - 200        | 1%      | 120                            | -             | 100        | -          | -           |
| b3-08 | Speed Estimation ACR P Gain          | 0.00 - 6.00    | 0.01    | 0.50 *1                        | 0.50 *1       | 0.50 *1    | 0.50 *1    | 0.50 *1     |
| b3-09 | Speed Estimation ACR I Time          | 0.0 - 1000.0   | 0.1 ms  | 2.0                            | 2.0           | 2.0        | 2.0        | 2.0         |
| b3-14 | Bi-directional Speed Search          | 0 - 1          | 1       | 1                              | 0             | 1          | -          | 1           |
| b5-15 | PID Sleep Function Start Level       | 0.0 - 400.0    | 0.1 Hz  | 0.0                            | 0.0           | 0.0        | 0.0        | 0.0         |
| b6-01 | Dwell Reference at Start             | 0.0 - 400.0    | 0.1 Hz  | 0.0                            | 0.0           | 0.0        | 0.0        | 0.0         |
| b6-03 | Dwell Reference at Stop              | 0.0 - 400.0    | 0.1 Hz  | 0.0                            | 0.0           | 0.0        | 0.0        | 0.0         |
| b8-02 | Energy Saving Gain                   | 0.0 - 10.0     | 0.1     | -                              | -             | 0.7        | 1.0        | 1.0         |
| b8-03 | Energy Saving Filter Time            | 0.00 - 10.00   | 0.01 s  | -                              | -             | 0.50 *2    | 0.01 *2    | 0.01 *2     |
| b8-19 | E-Save Search Injection Freq         | 10 - 300       | 1 Hz    | -                              | -             | -          | -          | -           |
| C1-11 | Accel/Decel Time Switching Frequency | 0.0 - 400.0    | 0.1 Hz  | 0.0                            | 0.0           | 0.0        | 0.0        | 0.0         |
| C2-01 | S-Curve Time @ Start of Accel        | 0.00 - 10.00   | 0.01 s  | 0.20                           | 0.20          | 0.20       | 0.20       | 0.20        |
| C3-01 | Slip Compensation Gain               | 0.0 - 2.5      | 0.1     | 0.0                            | -             | 1.0        | 1.0        | 0.1         |
| C3-02 | Slip Compensation Delay Time         | 0 - 10000      | 1 ms    | 2000                           | -             | 200        | -          | -           |
| C4-01 | Torque Compensation Gain             | 0.00 - 2.50    | 0.01    | 1.00                           | 1.00          | 1.00       | -          | -           |
| C4-02 | Torque Compensation Delay Time       | 0 - 10000      | 1 ms    | 200                            | 200           | 20         | -          | -           |
| C5-01 | ASR Proportional Gain 1              | 0.00 - 300.00  | 0.01    | -                              | 0.20          | -          | 20.00      | 10.00       |
| C5-02 | ASR Integral Time 1                  | 0.000 - 60.000 | 0.001 s | -                              | 0.200         | -          | 0.500      | 0.500       |
| C5-03 | ASR Proportional Gain 2              | 0.00 - 300.00  | 0.01    | -                              | 0.02          | -          | 20.00      | 20.00       |

## 1.18 Parameters that Change from the Default Settings with A1-02 [Control Method Selection]

| No.   | Name                             | Range              | Unit    | Control Method (A1-02 Setting) |                        |                     |                     |                     |
|-------|----------------------------------|--------------------|---------|--------------------------------|------------------------|---------------------|---------------------|---------------------|
|       |                                  |                    |         | V/f<br>(0)                     | CL-V/f<br>(1)          | OLV<br>(2)          | CLV<br>(3)          | AOLV<br>(4)         |
| C5-04 | ASR Integral Time 2              | 0.000 - 10.000     | 0.001 s | -                              | 0.050                  | -                   | 0.500               | 0.500               |
| C5-06 | ASR Delay Time                   | 0.000 - 0.500      | 0.001 s | -                              | -                      | -                   | 0.004               | 0.004               |
| C5-07 | ASR Gain Switchover Frequency    | 0.0 - 400.0        | 0.1 Hz  | -                              | -                      | -                   | 0.0                 | 0.0                 |
| C6-02 | Carrier Frequency Selection      | 1 - F              | 1       | 1 *3                           | 1 *3                   | 1 *3                | 1                   | 1                   |
| d3-01 | Jump Frequency 1                 | 0.0 - 400.0        | 0.1 Hz  | 0.0                            | 0.0                    | 0.0                 | 0.0                 | 0.0                 |
| d3-02 | Jump Frequency 2                 | 0.0 - 400.0        | 0.1 Hz  | 0.0                            | 0.0                    | 0.0                 | 0.0                 | 0.0                 |
| d3-03 | Jump Frequency 3                 | 0.0 - 400.0        | 0.1 Hz  | 0.0                            | 0.0                    | 0.0                 | 0.0                 | 0.0                 |
| d3-04 | Jump Frequency Width             | 0.0 - 20.0         | 0.1 Hz  | 1.0                            | 1.0                    | 1.0                 | 1.0                 | 1.0                 |
| d5-02 | Torque Reference Delay Time      | 0 - 1000           | 1 ms    | -                              | -                      | -                   | 0                   | 0                   |
| E1-04 | Maximum Output Frequency         | 40.0 - 400.0 *3 *4 | 0.1 Hz  | 60.0 *5                        | 60.0 *5                | 60.0                | 60.0                | 60.0                |
| E1-05 | Maximum Output Voltage           | 0.0 - 255.0 *6     | 0.1 V   | 200.0 *5                       | 200.0 *5               | 200.0               | 200.0               | 200.0               |
| E1-06 | Base Frequency                   | 0.0 - 400.0 *4     | 0.1 Hz  | 60.0 *5                        | 60.0 *5                | 60.0                | 60.0                | 60.0                |
| E1-07 | Mid Point A Frequency            | 0.0 - 400.0 *4     | 0.1 Hz  | 3.0 *5                         | 3.0 *5                 | 3.0                 | -                   | 3.0                 |
| E1-08 | Mid Point A Voltage              | 0.0 - 255.0 *6     | 0.1 V   | 15.0 *5                        | 15.0 *5                | 11.0                | -                   | 10.0                |
| E1-09 | Minimum Output Frequency         | 0.0 - 400.0 *4     | 0.1 Hz  | 1.5 *5                         | 1.5 *5                 | 0.5                 | 0.0                 | 0.6                 |
| E1-10 | Minimum Output Voltage           | 0.0 - 255.0 *6     | 0.1 V   | 9.0 *5                         | 9.0 *5                 | 2.0                 | -                   | 2.0                 |
| F1-01 | Encoder 1 Pulse Count (PPR)      | 0 - 60000          | 1 ppr   | -                              | 600                    | -                   | 600                 | 600                 |
| F1-05 | Encoder 1 Rotation Selection     | 0 - 1              | 1       | -                              | 0                      | -                   | 0                   | 0                   |
| F1-09 | Overspeed Detection Delay Time   | 0.0 - 2.0          | 0.1 s   | -                              | 1.0                    | -                   | 0.0                 | 0.1                 |
| H4-20 | Analog Power Monitor 100% Level  | 0.00 - 650.00      | 0.01    | Default value of E2-11         | Default value of E2-11 | Determined by E2-11 | Determined by E2-11 | Determined by E2-11 |
| L1-01 | Motor Overload (oL1) Protection  | 0 - 4              | 1       | 1                              | 1                      | 1                   | 1                   | 1                   |
| L2-31 | KEB Start Voltage Offset Level   | 0 - 100 *6         | 1 V     | 0                              | 0                      | 0                   | 0                   | 0                   |
| L3-05 | Stall Prevention during RUN      | 0 - 3              | 1       | 2                              | 2                      | -                   | -                   | -                   |
| L3-20 | DC Bus Voltage Adjustment Gain   | 0.00 - 5.00        | 0.01    | 1.00                           | 1.00                   | 0.30                | 0.30                | 0.30                |
| L3-21 | OVSUPPRESSION Accel/Decel P Gain | 0.10 - 10.00       | 0.01    | 1.00                           | 1.00                   | 1.00                | 1.00                | 1.00                |
| L3-36 | Current Suppression Gain@Accel   | 0.0 - 100.0        | 0.1     | 10.0                           | 10.0                   | 20.0                | -                   | -                   |
| L4-01 | Speed Agree Detection Level      | 0.0 - 400.0 *7     | 0.1     | 0.0 Hz                         | 0.0 Hz                 | 0.0 Hz              | 0.0 Hz              | 0.0 Hz              |
| L4-02 | Speed Agree Detection Width      | 0.0 - 20.0         | 0.1     | 2.0 Hz                         | 2.0 Hz                 | 2.0 Hz              | 2.0 Hz              | 2.0 Hz              |

## 1.18 Parameters that Change from the Default Settings with A1-02 [Control Method Selection]

| No.   | Name                              | Range              | Unit    | Control Method (A1-02 Setting) |            |         |         |          |
|-------|-----------------------------------|--------------------|---------|--------------------------------|------------|---------|---------|----------|
|       |                                   |                    |         | V/f (0)                        | CL-V/f (1) | OLV (2) | CLV (3) | AOLV (4) |
| L4-03 | Speed Agree Detection Level (+/-) | -400.0 - +400.0 *8 | 0.1     | 0.0 Hz                         | 0.0 Hz     | 0.0 Hz  | 0.0 Hz  | 0.0 Hz   |
| L4-04 | Speed Agree Detection Width (+/-) | 0.0 - 20.0         | 0.1     | 2.0 Hz                         | 2.0 Hz     | 2.0 Hz  | 2.0 Hz  | 2.0 Hz   |
| L8-38 | Carrier Frequency Reduction       | 0 - 2              | 1       | *3                             | *3         | *3      | *3      | -        |
| L8-40 | Carrier Freq Reduction Off-Delay  | 0.00 - 2.00        | 0.01 s  | 0.50                           | 0.50       | 0.50    | 0.50    | -        |
| L8-90 | STPo Detection Level (Low Speed)  | 0 - 5000           | 1       | -                              | -          | -       | -       | -        |
| n1-15 | PWM Voltage Offset Calibration    | 0 - 2              | 1       | 1                              | 1          | 1       | 1       | 2        |
| n5-04 | Speed Response Frequency          | 0.00 - 500.00      | 0.00 Hz | -                              | -          | -       | 50.00   | 50.00    |
| n8-35 | Initial Pole Detection Method     | 0 - 2              | 1       | -                              | -          | -       | -       | -        |
| n8-51 | Pull-in Current @ Acceleration    | 0 - 200            | 1%      | -                              | -          | -       | -       | -        |
| o1-03 | Frequency Display Unit Selection  | 0 - 3              | 1       | 0                              | 0          | 0       | 0       | 0        |
| o1-04 | V/f Pattern Display Unit          | 0 - 1              | 1       | -                              | -          | -       | 0       | 0        |

\*1 Depends on the setting of o2-04 [Drive Model (KVA) Selection].

\*2 Drive models 2211 to 2415 and 4103 to 4720 use these default settings when C6-01 = 1 [Normal / Heavy Duty Selection = Normal Duty Rating]. Drive models 2257 to 2415, 4140 to 4720 use these default settings when C6-01 = 0 [Heavy Duty Rating].

- A1-02 = 2 [Open Loop Vector]: 2.00
- A1-02 = 3, 4 [Closed Loop Vector, Advanced Open Loop Vector]: 0.05

\*3 The default setting varies depending on the setting of C6-01 [Normal / Heavy Duty Selection].

\*4 The setting range varies depending on the setting of E5-01 [PM Motor Code Selection] when A1-02 = 5 [Control Method Selection = PM Open Loop Vector].

\*5 The default setting changes when the drive model and setting for E1-03 [V/f Pattern Selection] change.

\*6 This is the value for 200 V class drives. Double the value for 400 V class drives.

\*7 The maximum value within the setting range is 100.0 when A1-02 = 5 or 7 [Control Method Selection = PM Open Loop Vector or PM Closed Loop Vector].

\*8 The setting range is -100.0 to 100.0 when A1-02 = 5 or 7 [Control Method Selection = PM Open Loop Vector or PM Closed Loop Vector].

### ◆ A1-02 = 5 to 8 [Control Method for PM Motors and EZ Vector Control]

| No.   | Name                             | Range        | Unit   | Control Method (A1-02 Setting) |             |            |           |
|-------|----------------------------------|--------------|--------|--------------------------------|-------------|------------|-----------|
|       |                                  |              |        | OLV/PM (5)                     | AOLV/PM (6) | CLV/PM (7) | EZOLV (8) |
| b2-01 | DC Injection/Zero SpeedThreshold | 0.0 - 10.0   | 0.1    | 0.5 Hz                         | 1.0%        | 0.5%       | 1.0%      |
| b2-04 | DC Inject Braking Time at Stop   | 0.00 - 10.00 | 0.01 s | 0.00                           | 0.00        | 0.00       | 0.00      |
| b3-01 | Speed Search at Start Selection  | 0 - 1        | 1      | 0                              | 0           | -          | 0         |
| b3-02 | SpeedSearch Deactivation Current | 0 - 200      | 1%     | -                              | -           | -          | -         |
| b3-08 | Speed Estimation ACR P Gain      | 0.00 - 6.00  | 0.01   | 0.50 *I                        | 0.50 *I     | -          | 0.30 *I   |
| b3-09 | Speed Estimation ACR I Time      | 0.0 - 1000.0 | 0.1 ms | 2.0                            | 4.0         | -          | 4.0       |

## 1.18 Parameters that Change from the Default Settings with A1-02 [Control Method Selection]

| No.   | Name                                 | Range           | Unit    | Control Method (A1-02 Setting) |                     |                     |                     |
|-------|--------------------------------------|-----------------|---------|--------------------------------|---------------------|---------------------|---------------------|
|       |                                      |                 |         | OLV/PM (5)                     | AOLV/PM (6)         | CLV/PM (7)          | EZOLV (8)           |
| b3-14 | Bi-directional Speed Search          | 0 - 1           | 1       | -                              | -                   | -                   | 0                   |
| b5-15 | PID Sleep Function Start Level       | 0.0 - 400.0 *2  | 0.1     | 0.0 Hz                         | 0.0 %               | 0.0 %               | 0.0 %               |
| b6-01 | Dwell Reference at Start             | 0.0 - 400.0 *2  | 0.1     | 0.0 Hz                         | 0.0 %               | 0.0 %               | 0.0 %               |
| b6-03 | Dwell Reference at Stop              | 0.0 - 400.0 *2  | 0.1     | 0.0 Hz                         | 0.0 %               | 0.0 %               | 0.0 %               |
| b8-02 | Energy Saving Gain                   | 0.0 - 10.0      | 0.1     | -                              | -                   | -                   | -                   |
| b8-03 | Energy Saving Filter Time            | 0.00 - 10.00    | 0.01 s  | -                              | -                   | -                   | -                   |
| b8-19 | E-Save Search Injection Freq         | 10 - 300        | 1 Hz    | -                              | 100                 | 100                 | 20                  |
| C1-11 | Accel/Decel Time Switching Frequency | 0.0 - 400.0 *2  | 0.1     | 0.0 Hz                         | 0.0 %               | 0.0 %               | 0.0 %               |
| C2-01 | S-Curve Time @ Start of Accel        | 0.00 - 10.00    | 0.01 s  | 1.00                           | 0.20                | 0.20                | 1.00                |
| C3-01 | Slip Compensation Gain               | 0.0 - 2.5       | 0.1     | -                              | -                   | -                   | Determined by E9-01 |
| C3-02 | Slip Compensation Delay Time         | 0 - 10000       | 1 ms    | -                              | -                   | -                   | 200                 |
| C4-01 | Torque Compensation Gain             | 0.00 - 2.50     | 0.01    | 0.00                           | -                   | -                   | 0.00                |
| C4-02 | Torque Compensation Delay Time       | 0 - 10000       | 1 ms    | 100                            | -                   | -                   | 100                 |
| C5-01 | ASR Proportional Gain 1              | 0.00 - 300.00   | 0.01    | -                              | 10.00               | 20.00               | 10.00               |
| C5-02 | ASR Integral Time 1                  | 0.000 - 60.000  | 0.001 s | -                              | 0.500               | 0.500               | 0.500               |
| C5-03 | ASR Proportional Gain 2              | 0.00 - 300.00   | 0.01    | -                              | 10.00               | 20.00               | 10.00               |
| C5-04 | ASR Integral Time 2                  | 0.000 - 10.000  | 0.001 s | -                              | 0.500               | 0.500               | 0.500               |
| C5-06 | ASR Delay Time                       | 0.000 - 0.500   | 0.001 s | -                              | 0.016               | 0.004               | 0.004               |
| C5-07 | ASR Gain Switchover Frequency        | 0.0 - 400.0 *2  | 0.1     | -                              | 0.0 %               | 0.0 %               | 0.0 %               |
| C6-02 | Carrier Frequency Selection          | 1 - F           | 1       | 2                              | 2                   | 2                   | 2                   |
| d3-01 | Jump Frequency 1                     | 0.0 - 400.0 *2  | 0.1     | 0.0 Hz                         | 0.0 %               | 0.0 %               | 0.0 %               |
| d3-02 | Jump Frequency 2                     | 0.0 - 400.0 *2  | 0.1     | 0.0 Hz                         | 0.0 %               | 0.0 %               | 0.0 %               |
| d3-03 | Jump Frequency 3                     | 0.0 - 400.0 *2  | 0.1     | 0.0 Hz                         | 0.0 %               | 0.0 %               | 0.0 %               |
| d3-04 | Jump Frequency Width                 | 0.0 - 20.0 *3   | 0.1     | 1.0 Hz                         | 1.0 %               | 1.0 %               | 1.0 %               |
| d5-02 | Torque Reference Delay Time          | 0 - 1000        | 1 ms    | -                              | 0                   | 0                   | -                   |
| E1-04 | Maximum Output Frequency             | 40.0 - 400.0 *4 | 0.1 Hz  | Determined by E5-01            | Determined by E5-01 | Determined by E5-01 | -                   |
| E1-05 | Maximum Output Voltage               | 0.0 - 255.0 *5  | 0.1 V   | Determined by E5-01            | Determined by E5-01 | Determined by E5-01 | -                   |
| E1-06 | Base Frequency                       | 0.0 - 400.0     | 0.1 Hz  | Determined by E5-01            | Determined by E5-01 | Determined by E5-01 | -                   |
| E1-07 | Mid Point A Frequency                | 0.0 - 400.0     | 0.1 Hz  | -                              | -                   | -                   | -                   |
| E1-08 | Mid Point A Voltage                  | 0.0 - 255.0 *5  | 0.1 V   | -                              | -                   | -                   | -                   |
| E1-09 | Minimum Output Frequency             | 0.0 - 400.0     | 0.1 Hz  | Determined by E5-01            | Determined by E5-01 | Determined by E5-01 | -                   |
| E1-10 | Minimum Output Voltage               | 0.0 - 255.0 *5  | 0.1 V   | -                              | -                   | -                   | -                   |
| F1-01 | Encoder 1 Pulse Count (PPR)          | 0 - 60000       | 1 ppr   | -                              | -                   | 1024                | -                   |

## 1.18 Parameters that Change from the Default Settings with A1-02 [Control Method Selection]

| No.   | Name                             | Range              | Unit    | Control Method (A1-02 Setting) |                     |                     |                     |
|-------|----------------------------------|--------------------|---------|--------------------------------|---------------------|---------------------|---------------------|
|       |                                  |                    |         | OLV/PM<br>(5)                  | AOLV/PM<br>(6)      | CLV/PM<br>(7)       | EZOLV<br>(8)        |
| F1-05 | Encoder 1 Rotation Selection     | 0 - 1              | 1       | -                              | -                   | 1                   | -                   |
| F1-09 | Overspeed Detection Delay Time   | 0.0 - 2.0          | 0.1 s   | -                              | 0.0                 | 0.0                 | 0.0                 |
| H4-20 | Analog Power Monitor 100% Level  | 0.00 - 650.00      | 0.01    | Determined by E5-01            | Determined by E5-01 | Determined by E5-01 | Determined by E9-07 |
| L1-01 | Motor Overload (oL1) Protection  | 0 - 4              | 1       | 4                              | 4                   | 5                   | Determined by E9-01 |
| L2-31 | KEB Start Voltage Offset Level   | 0 - 100 *5         | 1 V     | 50                             | 50                  | 50                  | 50                  |
| L3-05 | Stall Prevention during RUN      | 0 - 3              | 1       | 1                              | -                   | -                   | 3                   |
| L3-20 | DC Bus Voltage Adjustment Gain   | 0.00 - 5.00        | 0.01    | 0.65                           | 0.65                | 0.65                | 0.65                |
| L3-21 | OVSUPPRESSION Accel/Decel P Gain | 0.10 - 10.00       | 0.01    | 1.00                           | 1.00                | 1.00                | 1.00                |
| L3-36 | Current Suppression Gain@Accel   | 0.0 - 100.0        | 0.1     | -                              | -                   | -                   | -                   |
| L4-01 | Speed Agree Detection Level      | 0.0 - 400.0 *2     | 0.1     | 0.0 Hz                         | 0.0 %               | 0.0 %               | 0.0 %               |
| L4-02 | Speed Agree Detection Width      | 0.0 - 20.0 *3      | 0.1     | 2.0 Hz                         | 4.0%                | 4.0%                | 4.0%                |
| L4-03 | Speed Agree Detection Level(+/-) | -400.0 - +400.0 *6 | 0.1     | 0.0 Hz                         | 0.0 %               | 0.0 %               | 0.0 %               |
| L4-04 | Speed Agree Detection Width(+/-) | 0.0 - 20.0 *3      | 0.1     | 2.0 Hz                         | 4.0%                | 4.0%                | 4.0%                |
| L8-38 | Carrier Frequency Reduction      | 0 - 2              | 1       | 0                              | -                   | 0                   | 0                   |
| L8-40 | Carrier Freq Reduction Off-Delay | 0.00 - 2.00        | 0.01 s  | 0.00                           | -                   | 0.00                | 0.00                |
| L8-90 | STPo Detection Level (Low Speed) | 0 - 5000           | 1       | 0                              | 80                  | -                   | 0                   |
| n1-15 | PWM Voltage Offset Calibration   | 0 - 2              | 1       | 1                              | 1                   | 1                   | 1                   |
| n5-04 | Speed Response Frequency         | 0.00 - 500.00      | 0.00 Hz | -                              | 20.00               | 50.00               | -                   |
| n8-35 | Initial Pole Detection Method    | 0 - 2              | 1       | 0                              | 1                   | 1                   | -                   |
| n8-51 | Pull-in Current @ Acceleration   | 0 - 200            | 1%      | 50%                            | -                   | -                   | 80%                 |
| o1-03 | Frequency Display Unit Selection | 0 - 3              | 1       | 2                              | 2                   | 2                   | 0                   |
| o1-04 | V/f Pattern Display Unit         | 0 - 1              | 1       | -                              | 1                   | 1                   | 0                   |

\*1 Depends on the setting of o2-04.

\*2 The setting range is 0.0 to 100.0 when A1-02 = 6 or 7 [PM Advanced Open Loop Vector or PM Closed Loop Vector].

\*3 The setting range is 0.0 to 40.0 when A1-02 = 6 or 7 [PM Advanced Open Loop Vector or PM Closed Loop Vector].

\*4 The default setting changes when the setting for C6-01 [Normal / Heavy Duty Selection] changes.

\*5 This is the value for 200 V class drives. Double the value for 400 V class drives.

\*6 The setting range is -100.0 to +100.0 when A1-02 = 6 or 7 [PM Advanced Open Loop Vector or PM Closed Loop Vector].

## 1.19 Parameters that Change from the Default Settings with E3-01 [Motor 2 Control Mode Selection]

### 1.19 Parameters that Change from the Default Settings with E3-01 [Motor 2 Control Mode Selection]

The values for the parameters in these tables depend on the values for parameter *E3-01*. When you change the setting for *E3-01*, the default settings will change.

| No.   | Name                                | Range             | Unit                   | Motor 2 Control Method (setting value of E3-01) |            |         |         |
|-------|-------------------------------------|-------------------|------------------------|---|------------|---------|---------|
|       |                                     |                   |                        | V/f (0)   | CL-V/f (1) | OLV (2) | CLV (3) |
| C3-21 | Motor 2 Slip Compensation Gain      | 0.0 - 2.50        | 0.1                    | 0.0   | -          | 1.0     | 1.0     |
| C3-22 | Motor 2 Slip Comp Delay Time        | 0 - 10000         | 1 ms                   | 2000  | -          | 200     | -       |
| C5-21 | Motor 2 ASR Proportional Gain 1 (P) | 0.00 - 300.00     | 0.01                   | -   | 0.20       | -       | 20.00   |
| C5-22 | Motor 2 ASR Integral Time 1 (I)     | 0.000 - 10.000    | 0.001 s                | -   | 0.200      | -       | 0.500   |
| C5-23 | Motor 2 ASR Proportional Gain 2 (P) | 0.00 - 300.00     | 0.01                   | -   | 0.02       | -       | 20.00   |
| C5-24 | Motor 2 ASR Integral Time 2 (I)     | 0.000 - 10.000    | 0.001 s                | -   | 0.050      | -       | 0.500   |
| C5-26 | Motor 2 ASR Delay Time              | 0.000 - 0.500     | 0.001 s                | -   | -          | -       | 0.004   |
| E3-04 | Motor 2 Maximum Output Frequency    | 40.0 - 590.0      | 0.1 Hz                 | 60.0  | 60.0       | 60.0    | 60.0    |
| E3-05 | Motor 2 Maximum Output Voltage      | 0.0 - 255.0<br>*1 | 0.1 V                  | 200.0   | 200.0      | 200.0   | 200.0   |
| E3-06 | Motor 2 Base Frequency              | 0.0 - 590.0       | 0.1 Hz                 | 60.0  | 60.0       | 60.0    | 60.0    |
| E3-07 | Motor 2 Mid Point A Frequency       | 0.0 - 590.0       | 0.1 Hz                 | 3.0   | 3.0        | 3.0     | -       |
| E3-08 | Motor 2 Mid Point A Voltage         | 0.0 - 255.0<br>*1 | 0.1 V                  | 15.0  | 15.0       | 11.0    | -       |
| E3-09 | Motor 2 Minimum Output Frequency    | 0.0 - 590.0       | 0.1 Hz                 | 1.5   | 1.5        | 0.5     | 0.0     |
| E3-10 | Motor 2 Minimum Output Voltage      | 0.0 - 255.0<br>*1 | 0.1 V                  | 9.0   | 9.0        | 2.0     | -       |
| E3-11 | Motor 2 Mid Point B Frequency       | 0.0 - 590.0       | Determined by<br>o1-04 | 0.0   | 0.0        | 0.0     | 0.0     |
| E3-12 | Motor 2 Mid Point B Voltage         | 0.0 - 255.0<br>*1 | 0.1 V                  | 0.0   | 0.0        | 0.0     | 0.0     |
| E3-13 | Motor 2 Base Voltage                | 0.0 - 255.0<br>*1 | 0.1 V                  | 0.0   | 0.0        | 0.0     | 0.0     |

\*1 This is the value for 200 V class drives. Double the value for 400 V class drives.

## 1.20 Parameters Changed by E1-03 [V/f Pattern Selection]

The values for parameters *A1-02* [Control Method Selection] and *E1-03* [V/f Pattern Selection] changes the default settings for the parameters in these tables:

Table 1.1 Parameters Changed by E1-03 (2004 to 2021 and 4002 to 4012)

| No.         | Unit | Setting Value |       |       |       |       |       |       |       |       |       |       |       |       |       |       | Control Method (A1-02 Setting) |         |         |            |              |            |
|-------------|------|---------------|-------|-------|-------|-------|-------|-------|-------|-------|-------|-------|-------|-------|-------|-------|--------------------------------|---------|---------|------------|--------------|------------|
|             |      | 0             | 1     | 2     | 3     | 4     | 5     | 6     | 7     | 8     | 9     | A     | B     | C     | D     | E     | F                              | OLV (2) | CLV (3) | OLV/PM (5) | AOL V/PM (6) | CLV/PM (7) |
| E1-04       | Hz   | 50.0          | 60.0  | 60.0  | 72.0  | 50.0  | 50.0  | 60.0  | 60.0  | 50.0  | 50.0  | 60.0  | 60.0  | 90.0  | 120.0 | 180.0 | 60.0<br>*1                     | 60.0    | 60.0    | *2         | *2           | *2         |
| E1-05<br>*3 | V    | 200.0         | 200.0 | 200.0 | 200.0 | 200.0 | 200.0 | 200.0 | 200.0 | 200.0 | 200.0 | 200.0 | 200.0 | 200.0 | 200.0 | 200.0 | 230.0<br>*1                    | 230.0   | 230.0   | *2         | *2           | *2         |
| E1-06       | Hz   | 50.0          | 60.0  | 50.0  | 60.0  | 50.0  | 50.0  | 60.0  | 60.0  | 50.0  | 50.0  | 60.0  | 60.0  | 60.0  | 60.0  | 60.0  | 60.0<br>*1                     | 60.0    | 60.0    | *2         | *2           | *2         |
| E1-07       | Hz   | 2.5           | 3.0   | 3.0   | 3.0   | 25.0  | 25.0  | 30.0  | 30.0  | 2.5   | 2.5   | 3.0   | 3.0   | 3.0   | 3.0   | 3.0   | 3.0<br>*1                      | 3.0     | -       | -          | -            | -          |
| E1-08<br>*3 | V    | 15.0          | 15.0  | 15.0  | 15.0  | 35.0  | 50.0  | 35.0  | 50.0  | 19.0  | 24.0  | 19.0  | 24.0  | 15.0  | 15.0  | 15.0  | 17.3<br>*1                     | 13.8    | -       | -          | -            | -          |
| E1-09       | Hz   | 1.3           | 1.5   | 1.5   | 1.5   | 1.3   | 1.3   | 1.5   | 1.5   | 1.3   | 1.3   | 1.5   | 1.5   | 1.5   | 1.5   | 1.5   | 1.5<br>*1                      | 0.5     | 0.0     | *2         | *2           | 0.0        |
| E1-10<br>*3 | V    | 9.0           | 9.0   | 9.0   | 9.0   | 8.0   | 9.0   | 8.0   | 9.0   | 11.0  | 13.0  | 11.0  | 15.0  | 9.0   | 9.0   | 9.0   | 10.2<br>*1                     | 2.9     | -       | -          | -            | -          |

\*1 These values are the default settings for *E1-04* to *E1-10* and *E3-04* to *E3-10* [V/f Pattern for Motor 2]. These settings are the same as those for the V/f pattern when *E1-03* = 1 [Const Trq, 60Hz base, 60Hz max].

\*2 The default setting varies depending on the setting of *E5-01* [PM Motor Code Selection].

\*3 This is the value for 200 V class drives. Double the value for 400 V class drives.

Table 1.2 Parameters Changed by E1-03 (2030 to 2211 and 4018 to 4103)

| No.         | Unit | Setting Value |       |       |       |       |       |       |       |       |       |       |       |       |       |       | Control Method (A1-02 Setting) |         |         |            |              |            |
|-------------|------|---------------|-------|-------|-------|-------|-------|-------|-------|-------|-------|-------|-------|-------|-------|-------|--------------------------------|---------|---------|------------|--------------|------------|
|             |      | 0             | 1     | 2     | 3     | 4     | 5     | 6     | 7     | 8     | 9     | A     | B     | C     | D     | E     | F                              | OLV (2) | CLV (3) | OLV/PM (5) | AOL V/PM (6) | CLV/PM (7) |
| E1-04       | Hz   | 50.0          | 60.0  | 60.0  | 72.0  | 50.0  | 50.0  | 60.0  | 60.0  | 50.0  | 50.0  | 60.0  | 60.0  | 90.0  | 120.0 | 180.0 | 60.0<br>*1                     | 60.0    | 60.0    | *2         | *2           | *2         |
| E1-05<br>*3 | V    | 200.0         | 200.0 | 200.0 | 200.0 | 200.0 | 200.0 | 200.0 | 200.0 | 200.0 | 200.0 | 200.0 | 200.0 | 200.0 | 200.0 | 200.0 | 230.0<br>*1                    | 230.0   | 230.0   | *2         | *2           | *2         |
| E1-06       | Hz   | 50.0          | 60.0  | 50.0  | 60.0  | 50.0  | 50.0  | 60.0  | 60.0  | 50.0  | 50.0  | 60.0  | 60.0  | 60.0  | 60.0  | 60.0  | 60.0<br>*1                     | 60.0    | 60.0    | *2         | *2           | *2         |
| E1-07       | Hz   | 2.5           | 3.0   | 3.0   | 3.0   | 25.0  | 25.0  | 30.0  | 30.0  | 2.5   | 2.5   | 3.0   | 3.0   | 3.0   | 3.0   | 3.0   | 3.0<br>*1                      | 3.0     | -       | -          | -            | -          |
| E1-08<br>*3 | V    | 14.0          | 14.0  | 14.0  | 14.0  | 35.0  | 50.0  | 35.0  | 50.0  | 18.0  | 23.0  | 18.0  | 23.0  | 14.0  | 14.0  | 14.0  | 16.1<br>*1                     | 12.7    | -       | -          | -            | -          |
| E1-09       | Hz   | 1.3           | 1.5   | 1.5   | 1.5   | 1.3   | 1.3   | 1.5   | 1.5   | 1.3   | 1.3   | 1.5   | 1.5   | 1.5   | 1.5   | 1.5   | 1.5<br>*1                      | 0.5     | 0.0     | *2         | *2           | 0.0        |
| E1-10<br>*3 | V    | 7.0           | 7.0   | 7.0   | 7.0   | 6.0   | 7.0   | 6.0   | 7.0   | 9.0   | 11.0  | 9.0   | 13.0  | 7.0   | 7.0   | 7.0   | 8.1<br>*1                      | 2.3     | -       | -          | -            | -          |

\*1 These values are the default settings for *E1-04* to *E1-10* and *E3-04* to *E3-10* [V/f Pattern for Motor 2]. These settings are the same as those for the V/f pattern when *E1-03* = 1 [Const Trq, 60Hz base, 60Hz max].

\*2 The default setting varies depending on the setting of *E5-01* [PM Motor Code Selection].

\*3 This is the value for 200 V class drives. Double the value for 400 V class drives.

## 1.20 Parameters Changed by E1-03 [V/f Pattern Selection]

**Table 1.3 Parameters Changed by E1-03 (2257 to 2415 and 4140 to 4720)**

| No.         | Unit | Setting Value |       |       |       |       |       |       |       |       |       |       |       |       |       |       | Control Method (A1-02 Setting) |            |            |                   |                    |                   |
|-------------|------|---------------|-------|-------|-------|-------|-------|-------|-------|-------|-------|-------|-------|-------|-------|-------|--------------------------------|------------|------------|-------------------|--------------------|-------------------|
|             |      | 0             | 1     | 2     | 3     | 4     | 5     | 6     | 7     | 8     | 9     | A     | B     | C     | D     | E     | F                              | OLV<br>(2) | CLV<br>(3) | OLV/<br>PM<br>(5) | AOL<br>V/PM<br>(6) | CLV/<br>PM<br>(7) |
| E1-04       | Hz   | 50.0          | 60.0  | 60.0  | 72.0  | 50.0  | 50.0  | 60.0  | 60.0  | 50.0  | 50.0  | 60.0  | 60.0  | 90.0  | 120.0 | 180.0 | 60.0<br>*1                     | 60.0       | 60.0       | *2                | *2                 | *2                |
| E1-05<br>*3 | V    | 200.0         | 200.0 | 200.0 | 200.0 | 200.0 | 200.0 | 200.0 | 200.0 | 200.0 | 200.0 | 200.0 | 200.0 | 200.0 | 200.0 | 200.0 | 230.0<br>*1                    | 230.0      | 230.0      | *2                | *2                 | *2                |
| E1-06       | Hz   | 50.0          | 60.0  | 50.0  | 60.0  | 50.0  | 50.0  | 60.0  | 60.0  | 50.0  | 50.0  | 60.0  | 60.0  | 60.0  | 60.0  | 60.0  | 60.0<br>*1                     | 60.0       | 60.0       | *2                | *2                 | *2                |
| E1-07       | Hz   | 2.5           | 3.0   | 3.0   | 3.0   | 25.0  | 25.0  | 30.0  | 30.0  | 2.5   | 2.5   | 3.0   | 3.0   | 3.0   | 3.0   | 3.0   | 3.0<br>*1                      | 3.0        | -          | -                 | -                  | -                 |
| E1-08<br>*3 | V    | 12.0          | 12.0  | 12.0  | 12.0  | 35.0  | 50.0  | 35.0  | 50.0  | 15.0  | 20.0  | 15.0  | 20.0  | 12.0  | 12.0  | 12.0  | 13.8<br>*1                     | 12.7       | -          | -                 | -                  | -                 |
| E1-09       | Hz   | 1.3           | 1.5   | 1.5   | 1.5   | 1.3   | 1.3   | 1.5   | 1.5   | 1.3   | 1.3   | 1.5   | 1.5   | 1.5   | 1.5   | 1.5   | 1.5<br>*1                      | 0.5        | 0.0        | *2                | *2                 | 0.0               |
| E1-10<br>*3 | V    | 6.0           | 6.0   | 6.0   | 6.0   | 5.0   | 6.0   | 5.0   | 6.0   | 7.0   | 9.0   | 7.0   | 11.0  | 6.0   | 6.0   | 6.0   | 6.9<br>*1                      | 2.3        | -          | -                 | -                  | -                 |

\*1 These values are the default settings for E1-04 to E1-10 and E3-04 to E3-10 [V/f Pattern for Motor 2]. These settings are the same as those for the V/f pattern when E1-03 = 1 [Const Trq, 60Hz base, 60Hz max].

\*2 The default setting varies depending on the setting of E5-01 [PM Motor Code Selection].

\*3 This is the value for 200 V class drives. Double the value for 400 V class drives.



## 1.21 Defaults by Drive Model and Duty Rating ND/HD

The values for the parameters in these tables depend on the values for parameters *o2-04* and *C6-01*. Changing the settings for *o2-04* and *C6-01* will change the default settings.

### ◆ 200 V class

| No. */        | Name                             | Unit             | Default |        |        |        |        |        |        |        |
|---------------|----------------------------------|------------------|---------|--------|--------|--------|--------|--------|--------|--------|
|               |                                  |                  | 2004    |        | 2006   |        | 2008   |        | 2010   |        |
| -             | Drive Model                      | -                | HD      | ND     | HD     | ND     | HD     | ND     | HD     | ND     |
| C6-01         | Normal / Heavy Duty Selection    | -                | 0       | 1      | 0      | 1      | 0      | 1      | 0      | 1      |
| o2-04         | Drive Model (KVA) Selection      | Hex.             | 62      |        | 63     |        | 64     |        | 65     |        |
| E2-11 (E4-11) | Motor Rated Power (kW)           | kW               | 0.55    | 0.75   | 0.75   | 1.1    | 1.1    | 1.5    | 1.5    | 2.2    |
| b3-04         | V/f Gain during Speed Search     | %                | 100     | 100    | 100    | 100    | 100    | 100    | 100    | 100    |
| b3-06         | Speed Estimation Current Level 1 | -                | 1       | 1      | 0.5    | 0.5    | 0.5    | 0.5    | 0.5    | 0.5    |
| b3-08         | Speed Estimation ACR P Gain      | -                | 0.5     | 0.5    | 0.5    | 0.5    | 0.5    | 0.5    | 0.5    | 0.5    |
| b3-26         | Direction Determination Level    | -                | 1000    | 1000   | 1000   | 1000   | 1000   | 1000   | 1000   | 1000   |
| b8-03         | Energy Saving Filter Time        | s                | 0.50    | 0.50   | 0.50   | 0.50   | 0.50   | 0.50   | 0.50   | 0.50   |
| b8-04         | Energy Saving Coefficient Value  | -                | 288.2   | 223.7  | 223.7  | 196.6  | 196.6  | 169.4  | 169.4  | 156.8  |
| C5-17 (C5-37) | Motor Inertia                    | kgm <sup>2</sup> | 0.0015  | 0.0028 | 0.0028 | 0.0068 | 0.0068 | 0.0068 | 0.0068 | 0.0088 |
| C6-02         | Carrier Frequency Selection      | -                | 1       | 7      | 1      | 7      | 1      | 7      | 1      | 7      |
| E2-01 (E4-01) | Motor Rated Current (FLA)        | A                | 1.9     | 3.3    | 3.3    | 4.9    | 4.9    | 6.2    | 6.2    | 8.5    |
| E2-02 (E4-02) | Motor Rated Slip                 | Hz               | 2.9     | 2.5    | 2.5    | 2.6    | 2.6    | 2.6    | 2.6    | 2.9    |
| E2-03 (E4-03) | Motor No-Load Current            | A                | 1.2     | 1.8    | 1.8    | 2.3    | 2.3    | 2.8    | 2.8    | 3      |
| E2-05 (E4-05) | Motor Line-to-Line Resistance    | Ω                | 9.842   | 5.156  | 5.156  | 3.577  | 3.577  | 1.997  | 1.997  | 1.601  |
| E2-06 (E4-06) | Motor Leakage Inductance         | %                | 18.2    | 13.8   | 13.8   | 18.5   | 18.5   | 18.5   | 18.5   | 18.4   |
| E2-10 (E4-10) | Motor Iron Loss                  | W                | 14      | 26     | 26     | 38     | 38     | 53     | 53     | 77     |
| E5-01         | PM Motor Code Selection          | -                | 1202    | 1202   | 1203   | 1203   | FFFF   | FFFF   | 1205   | 1205   |
| L2-02         | Power Loss Ride Through Time     | s                | 0.1     | 0.1    | 0.2    | 0.2    | 0.3    | 0.3    | 0.3    | 0.3    |
| L2-03         | Minimum Baseblock Time           | s                | 0.2     | 0.3    | 0.3    | 0.4    | 0.4    | 0.4    | 0.4    | 0.5    |

## 1.21 Defaults by Drive Model and Duty Rating ND/HD

| No. */        | Name                             | Unit | Default |       |       |       |       |       |       |       |
|---------------|----------------------------------|------|---------|-------|-------|-------|-------|-------|-------|-------|
|               |                                  |      | 2004    |       | 2006  |       | 2008  |       | 2010  |       |
| -             | Drive Model                      | -    | HD      | ND    | HD    | ND    | HD    | ND    | HD    | ND    |
| C6-01         | Normal / Heavy Duty Selection    | -    | 0       | 1     | 0     | 1     | 0     | 1     | 0     | 1     |
| o2-04         | Drive Model (KVA) Selection      | Hex. | 62      |       | 63    |       | 64    |       | 65    |       |
| E2-11 (E4-11) | Motor Rated Power (kW)           | kW   | 0.55    | 0.75  | 0.75  | 1.1   | 1.1   | 1.5   | 1.5   | 2.2   |
| L2-04         | Powerloss V/f Recovery Ramp Time | s    | 0.3     | 0.3   | 0.3   | 0.3   | 0.3   | 0.3   | 0.3   | 0.3   |
| L2-05         | Undervoltage Detection Lvl (Uv1) | -    | 190     | 190   | 190   | 190   | 190   | 190   | 190   | 190   |
| L3-24         | Motor Accel Time for Inertia Cal | s    | 0.178   | 0.142 | 0.142 | 0.142 | 0.142 | 0.166 | 0.166 | 0.145 |
| L8-02         | Overheat Alarm Level             | °C   | 115     | 115   | 115   | 115   | 115   | 115   | 115   | 115   |
| L8-09         | Output Ground Fault Detection    | -    | 1       | 1     | 1     | 1     | 1     | 1     | 1     | 1     |
| L8-38         | Carrier Frequency Reduction      | -    | 2       | 2     | 2     | 2     | 2     | 2     | 2     | 2     |
| n1-01         | Hunting Prevention Selection     | -    | 1       | 1     | 1     | 1     | 1     | 1     | 1     | 1     |
| n1-03         | Hunting Prevention Time Constant | ms   | 10      | 10    | 10    | 10    | 10    | 10    | 10    | 10    |
| n5-02         | Motor Inertia Acceleration Time  | s    | 0.178   | 0.142 | 0.142 | 0.142 | 0.142 | 0.166 | 0.166 | 0.145 |

\*1 Parameters within parentheses are for motor 2.

| No. */        | Name                             | Unit | Default |       |       |       |       |       |       |       |
|---------------|----------------------------------|------|---------|-------|-------|-------|-------|-------|-------|-------|
|               |                                  |      | 2012    |       | 2018  |       | 2021  |       | 2030  |       |
| -             | Drive Model                      | -    | HD      | ND    | HD1   | ND1   | HD1   | ND1   | HD    | ND    |
| C6-01         | Normal / Heavy Duty Selection    | -    | 0       | 1     | 0     | 1     | 0     | 1     | 0     | 1     |
| o2-04         | Drive Model (KVA) Selection      | Hex. | 66      |       | 67    |       | 68    |       | 6A    |       |
| E2-11 (E4-11) | Motor Rated Power (kW)           | kW   | 2.2     | 3.0   | 3.0   | 3.7   | 3.7   | 5.5   | 5.5   | 7.5   |
| b3-04         | V/f Gain during Speed Search     | %    | 100     | 100   | 100   | 100   | 100   | 100   | 100   | 100   |
| b3-06         | Speed Estimation Current Level 1 | -    | 0.5     | 0.5   | 0.5   | 0.5   | 0.5   | 0.5   | 0.5   | 0.5   |
| b3-08         | Speed Estimation ACR P Gain      | -    | 0.5     | 0.5   | 0.5   | 0.5   | 0.5   | 0.5   | 0.5   | 0.5   |
| b3-26         | Direction Determination Level    | -    | 1000    | 1000  | 1000  | 1000  | 1000  | 1000  | 1000  | 1000  |
| b8-03         | Energy Saving Filter Time        | s    | 0.50    | 0.50  | 0.50  | 0.50  | 0.50  | 0.50  | 0.50  | 0.50  |
| b8-04         | Energy Saving Coefficient Value  | -    | 156.8   | 136.4 | 136.4 | 122.9 | 122.9 | 94.75 | 94.75 | 72.69 |

## 1.21 Defaults by Drive Model and Duty Rating ND/HD

| No. <sup>*1</sup> | Name                             | Unit             | Default |        |        |        |        |        |       |       |
|-------------------|----------------------------------|------------------|---------|--------|--------|--------|--------|--------|-------|-------|
|                   |                                  |                  | 2012    |        | 2018   |        | 2021   |        | 2030  |       |
| -                 | Drive Model                      | -                | HD      | ND     | HD1    | ND1    | HD1    | ND1    | HD    | ND    |
| C6-01             | Normal / Heavy Duty Selection    | -                | 0       | 1      | 0      | 1      | 0      | 1      | 0     | 1     |
| o2-04             | Drive Model (KVA) Selection      | Hex.             | 66      |        | 67     |        | 68     |        | 6A    |       |
| E2-11 (E4-11)     | Motor Rated Power (kW)           | kW               | 2.2     | 3.0    | 3.0    | 3.7    | 3.7    | 5.5    | 5.5   | 7.5   |
| C5-17 (C5-37)     | Motor Inertia                    | kgm <sup>2</sup> | 0.0088  | 0.0158 | 0.0158 | 0.0158 | 0.0158 | 0.0255 | 0.026 | 0.037 |
| C6-02             | Carrier Frequency Selection      | -                | 1       | 7      | 1      | 7      | 1      | 7      | 1     | 7     |
| E2-01 (E4-01)     | Motor Rated Current (FLA)        | A                | 8.5     | 11.4   | 11.4   | 14     | 14     | 19.6   | 19.6  | 26.6  |
| E2-02 (E4-02)     | Motor Rated Slip                 | Hz               | 2.9     | 2.7    | 2.7    | 2.73   | 2.73   | 1.5    | 1.5   | 1.3   |
| E2-03 (E4-03)     | Motor No-Load Current            | A                | 3       | 3.7    | 3.7    | 4.5    | 4.5    | 5.1    | 5.1   | 8     |
| E2-05 (E4-05)     | Motor Line-to-Line Resistance    | Ω                | 1.601   | 1.034  | 1.034  | 0.771  | 0.771  | 0.399  | 0.399 | 0.288 |
| E2-06 (E4-06)     | Motor Leakage Inductance         | %                | 18.4    | 19     | 19     | 19.6   | 19.6   | 18.2   | 18.2  | 15.5  |
| E2-10 (E4-10)     | Motor Iron Loss                  | W                | 77      | 91     | 91     | 112    | 112    | 172    | 172   | 262   |
| E5-01             | PM Motor Code Selection          | -                | 1206    | 1206   | FFFF   | FFFF   | 1208   | 1208   | 120A  | 120A  |
| L2-02             | Power Loss Ride Through Time     | s                | 0.5     | 0.5    | 1      | 1      | 1      | 1      | 1     | 1     |
| L2-03             | Minimum Baseblock Time           | s                | 0.5     | 0.5    | 0.5    | 0.6    | 0.6    | 0.7    | 0.7   | 0.8   |
| L2-04             | Powerloss V/f Recovery Ramp Time | s                | 0.3     | 0.3    | 0.3    | 0.3    | 0.3    | 0.3    | 0.3   | 0.3   |
| L2-05             | Undervoltage Detection Lvl (Uv1) | -                | 190     | 190    | 190    | 190    | 190    | 190    | 190   | 190   |
| L3-24             | Motor Accel Time for Inertia Cal | s                | 0.145   | 0.145  | 0.145  | 0.154  | 0.154  | 0.168  | 0.168 | 0.175 |
| L8-02             | Overheat Alarm Level             | °C               | 124     | 124    | 110    | 110    | 110    | 110    | 110   | 110   |
| L8-09             | Output Ground Fault Detection    | -                | 1       | 1      | 1      | 1      | 1      | 1      | 1     | 1     |
| L8-38             | Carrier Frequency Reduction      | -                | 2       | 2      | 2      | 2      | 2      | 2      | 2     | 2     |
| n1-01             | Hunting Prevention Selection     | -                | 1       | 1      | 1      | 1      | 1      | 1      | 1     | 1     |
| n1-03             | Hunting Prevention Time Constant | ms               | 10      | 10     | 10     | 10     | 10     | 10     | 10    | 10    |
| n5-02             | Motor Inertia Acceleration Time  | s                | 0.145   | 0.145  | 0.145  | 0.154  | 0.154  | 0.168  | 0.168 | 0.175 |

\*1 Parameters within parentheses are for motor 2.

Parameter List

1

## 1.21 Defaults by Drive Model and Duty Rating ND/HD

| No.           | Name                             | Unit             | Default |       |       |       |       |       |       |       |
|---------------|----------------------------------|------------------|---------|-------|-------|-------|-------|-------|-------|-------|
|               |                                  |                  | 2042    |       | 2056  |       | 2070  |       | 2082  |       |
| -             | Drive Model                      | -                | HD      | ND    | HD    | ND    | HD    | ND    | HD    | ND    |
| C6-01         | Normal / Heavy Duty Selection    | -                | 0       | 1     | 0     | 1     | 0     | 1     | 0     | 1     |
| o2-04         | Drive Model (KVA) Selection      | Hex.             | 6B      |       | 6D    |       | 6E    |       | 6F    |       |
| E2-11 (E4-11) | Motor Rated Power (kW)           | kW               | 7.5     | 11    | 11    | 15    | 15    | 18.5  | 18.5  | 22    |
| b3-04         | V/f Gain during Speed Search     | %                | 100     | 100   | 100   | 100   | 100   | 100   | 100   | 100   |
| b3-06         | Speed Estimation Current Level 1 | -                | 0.5     | 0.5   | 0.5   | 0.5   | 0.5   | 0.5   | 0.5   | 0.5   |
| b3-08         | Speed Estimation ACR P Gain      | -                | 0.5     | 0.5   | 0.5   | 0.5   | 0.5   | 0.5   | 0.5   | 0.5   |
| b3-26         | Direction Determination Level    | -                | 1000    | 1000  | 1000  | 1000  | 1000  | 1000  | 1000  | 1000  |
| b8-03         | Energy Saving Filter Time        | s                | 0.50    | 0.50  | 0.50  | 0.50  | 0.50  | 0.50  | 0.50  | 0.50  |
| b8-04         | Energy Saving Coefficient Value  | -                | 72.69   | 70.44 | 70.44 | 63.13 | 63.13 | 57.87 | 57.87 | 51.79 |
| C5-17 (C5-37) | Motor Inertia                    | kgm <sup>2</sup> | 0.037   | 0.053 | 0.053 | 0.076 | 0.076 | 0.138 | 0.138 | 0.165 |
| C6-02         | Carrier Frequency Selection      | -                | 1       | 7     | 1     | 7     | 1     | 7     | 1     | 7     |
| E2-01 (E4-01) | Motor Rated Current (FLA)        | A                | 26.6    | 39.7  | 39.7  | 53    | 53    | 65.8  | 65.8  | 77.2  |
| E2-02 (E4-02) | Motor Rated Slip                 | Hz               | 1.3     | 1.7   | 1.7   | 1.6   | 1.6   | 1.67  | 1.67  | 1.7   |
| E2-03 (E4-03) | Motor No-Load Current            | A                | 8       | 11.2  | 11.2  | 15.2  | 15.2  | 15.7  | 15.7  | 18.5  |
| E2-05 (E4-05) | Motor Line-to-Line Resistance    | Ω                | 0.288   | 0.23  | 0.23  | 0.138 | 0.138 | 0.101 | 0.101 | 0.079 |
| E2-06 (E4-06) | Motor Leakage Inductance         | %                | 15.5    | 19.5  | 19.5  | 17.2  | 17.2  | 15.7  | 20.1  | 19.5  |
| E2-10 (E4-10) | Motor Iron Loss                  | W                | 262     | 245   | 245   | 272   | 272   | 505   | 505   | 538   |
| E5-01         | PM Motor Code Selection          | -                | 120B    | 120B  | 120D  | 120D  | 120E  | 120E  | 120F  | 120F  |
| L2-02         | Power Loss Ride Through Time     | s                | 1       | 1     | 2     | 2     | 2     | 2     | 2     | 2     |
| L2-03         | Minimum Baseblock Time           | s                | 0.8     | 0.9   | 0.9   | 1     | 1     | 1     | 1     | 1     |
| L2-04         | Powerloss V/f Recovery Ramp Time | s                | 0.3     | 0.3   | 0.3   | 0.6   | 0.6   | 0.6   | 0.6   | 0.6   |
| L2-05         | Undervoltage Detection Lvl (Uv1) | -                | 190     | 190   | 190   | 190   | 190   | 190   | 190   | 190   |
| L3-24         | Motor Accel Time for Inertia Cal | s                | 0.175   | 0.265 | 0.265 | 0.244 | 0.244 | 0.317 | 0.317 | 0.355 |
| L8-02         | Overheat Alarm Level             | °C               | 110     | 110   | 115   | 115   | 120   | 120   | 133   | 130   |

## 1.21 Defaults by Drive Model and Duty Rating ND/HD

| No.           | Name                             | Unit | Default |       |       |       |       |       |       |       |
|---------------|----------------------------------|------|---------|-------|-------|-------|-------|-------|-------|-------|
|               |                                  |      | 2042    |       | 2056  |       | 2070  |       | 2082  |       |
| -             | Drive Model                      | -    | HD      | ND    | HD    | ND    | HD    | ND    | HD    | ND    |
| C6-01         | Normal / Heavy Duty Selection    | -    | 0       | 1     | 0     | 1     | 0     | 1     | 0     | 1     |
| o2-04         | Drive Model (KVA) Selection      | Hex. | 6B      |       | 6D    |       | 6E    |       | 6F    |       |
| E2-11 (E4-11) | Motor Rated Power (kW)           | kW   | 7.5     | 11    | 11    | 15    | 15    | 18.5  | 18.5  | 22    |
| L8-09         | Output Ground Fault Detection    | -    | 1       | 1     | 1     | 1     | 1     | 1     | 1     | 1     |
| L8-38         | Carrier Frequency Reduction      | -    | 2       | 2     | 2     | 2     | 2     | 2     | 2     | 2     |
| n1-01         | Hunting Prevention Selection     | -    | 1       | 1     | 2     | 2     | 2     | 2     | 2     | 2     |
| n1-03         | Hunting Prevention Time Constant | ms   | 10      | 10    | 10    | 10    | 10    | 10    | 10    | 10    |
| n5-02         | Motor Inertia Acceleration Time  | s    | 0.175   | 0.265 | 0.265 | 0.244 | 0.244 | 0.317 | 0.317 | 0.355 |

\*1 Parameters within parentheses are for motor 2.

| No. */        | Name                             | Unit             | Default |       |       |       |       |       |       |       |
|---------------|----------------------------------|------------------|---------|-------|-------|-------|-------|-------|-------|-------|
|               |                                  |                  | 2110    |       | 2138  |       | 2169  |       | 2211  |       |
| -             | Drive Model                      | -                | HD      | ND    | HD    | ND    | HD    | ND    | HD    | ND    |
| C6-01         | Normal / Heavy Duty Selection    | -                | 0       | 1     | 0     | 1     | 0     | 1     | 0     | 1     |
| o2-04         | Drive Model (KVA) Selection      | Hex.             | 70      |       | 72    |       | 73    |       | 74    |       |
| E2-11 (E4-11) | Motor Rated Power (kW)           | kW               | 22      | 30    | 30    | 37    | 37    | 45    | 45    | 55    |
| b3-04         | V/f Gain during Speed Search     | %                | 100     | 80    | 80    | 80    | 80    | 80    | 80    | 80    |
| b3-06         | Speed Estimation Current Level 1 | -                | 0.5     | 0.5   | 0.5   | 0.5   | 0.5   | 0.5   | 0.5   | 0.5   |
| b3-08         | Speed Estimation ACR P Gain      | -                | 0.5     | 0.5   | 0.5   | 0.5   | 0.5   | 0.5   | 0.5   | 0.5   |
| b3-26         | Direction Determination Level    | -                | 1000    | 1000  | 1000  | 1000  | 1000  | 1000  | 1000  | 1000  |
| b8-03         | Energy Saving Filter Time        | s                | 0.50    | 0.50  | 0.50  | 0.50  | 0.50  | 0.50  | 0.50  | 2.00  |
| b8-04         | Energy Saving Coefficient Value  | -                | 51.79   | 46.27 | 46.27 | 38.16 | 38.16 | 35.78 | 35.78 | 31.35 |
| C5-17 (C5-37) | Motor Inertia                    | kgm <sup>2</sup> | 0.165   | 0.220 | 0.220 | 0.273 | 0.273 | 0.333 | 0.333 | 0.490 |
| C6-02         | Carrier Frequency Selection      | -                | 1       | 7     | 1     | 7     | 1     | 7     | 1     | 7     |
| E2-01 (E4-01) | Motor Rated Current (FLA)        | A                | 77.2    | 105   | 105   | 131   | 131   | 160   | 160   | 190   |
| E2-02 (E4-02) | Motor Rated Slip                 | Hz               | 1.7     | 1.8   | 1.8   | 1.33  | 1.33  | 1.6   | 1.6   | 1.43  |

Parameter List

1

## 1.21 Defaults by Drive Model and Duty Rating ND/HD

| No. */        | Name                             | Unit | Default |       |       |       |       |       |       |       |
|---------------|----------------------------------|------|---------|-------|-------|-------|-------|-------|-------|-------|
|               |                                  |      | 2110    |       | 2138  |       | 2169  |       | 2211  |       |
| -             | Drive Model                      | -    | HD      | ND    | HD    | ND    | HD    | ND    | HD    | ND    |
| C6-01         | Normal / Heavy Duty Selection    | -    | 0       | 1     | 0     | 1     | 0     | 1     | 0     | 1     |
| o2-04         | Drive Model (KVA) Selection      | Hex. | 70      |       | 72    |       | 73    |       | 74    |       |
| E2-11 (E4-11) | Motor Rated Power (kW)           | kW   | 22      | 30    | 30    | 37    | 37    | 45    | 45    | 55    |
| E2-03 (E4-03) | Motor No-Load Current            | A    | 18.5    | 21.9  | 21.9  | 38.2  | 38.2  | 44    | 44    | 45.6  |
| E2-05 (E4-05) | Motor Line-to-Line Resistance    | Ω    | 0.079   | 0.064 | 0.064 | 0.039 | 0.039 | 0.03  | 0.03  | 0.022 |
| E2-06 (E4-06) | Motor Leakage Inductance         | %    | 19.5    | 20.8  | 20.8  | 18.8  | 18.8  | 20.2  | 20.2  | 20.5  |
| E2-10 (E4-10) | Motor Iron Loss                  | W    | 538     | 699   | 699   | 823   | 823   | 852   | 852   | 960   |
| E5-01         | PM Motor Code Selection          | -    | 1210    | 1210  | 1212  | 1212  | 1213  | 1213  | 1214  | 1214  |
| L2-02         | Power Loss Ride Through Time     | s    | 2       | 2     | 2     | 2     | 2     | 2     | 2     | 2     |
| L2-03         | Minimum Baseblock Time           | s    | 1       | 1.1   | 1.1   | 1.1   | 1.1   | 1.2   | 1.2   | 1.3   |
| L2-04         | Powerloss V/f Recovery Ramp Time | s    | 0.6     | 0.6   | 0.6   | 0.6   | 0.6   | 1     | 1     | 1     |
| L2-05         | Undervoltage Detection Lvl (Uv1) | -    | 190     | 190   | 190   | 190   | 190   | 190   | 190   | 190   |
| L3-24         | Motor Accel Time for Inertia Cal | s    | 0.355   | 0.323 | 0.323 | 0.32  | 0.32  | 0.387 | 0.387 | 0.317 |
| L8-02         | Overheat Alarm Level             | °C   | 105     | 105   | 115   | 115   | 105   | 105   | 105   | 105   |
| L8-09         | Output Ground Fault Detection    | -    | 1       | 1     | 1     | 1     | 1     | 1     | 1     | 1     |
| L8-38         | Carrier Frequency Reduction      | -    | 2       | 2     | 2     | 2     | 2     | 2     | 2     | 2     |
| n1-01         | Hunting Prevention Selection     | -    | 2       | 2     | 2     | 2     | 2     | 2     | 2     | 2     |
| n1-03         | Hunting Prevention Time Constant | ms   | 10      | 10    | 10    | 10    | 10    | 10    | 10    | 10    |
| n5-02         | Motor Inertia Acceleration Time  | s    | 0.355   | 0.323 | 0.323 | 0.32  | 0.32  | 0.387 | 0.387 | 0.317 |

\*1 Parameters within parentheses are for motor 2.

## 1.21 Defaults by Drive Model and Duty Rating ND/HD

| No.           | Name                             | Unit             | Default |       |       |       |       |       |
|---------------|----------------------------------|------------------|---------|-------|-------|-------|-------|-------|
|               |                                  |                  | 2257    |       | 2313  |       | 2360  |       |
| -             | Drive Model                      | -                | HD      | ND    | HD    | ND    | HD    | ND    |
| C6-01         | Normal / Heavy Duty Selection    | -                | 0       | 1     | 0     | 1     | 0     | 1     |
| o2-04         | Drive Model (KVA) Selection      | Hex.             | 75      |       | 76    |       | 77    |       |
| E2-11 (E4-11) | Motor Rated Power (kW)           | kW               | 55      | 75    | 75    | 90    | 90    | 110   |
| b3-04         | V/f Gain during Speed Search     | %                | 80      | 80    | 80    | 80    | 80    | 80    |
| b3-06         | Speed Estimation Current Level 1 | -                | 0.5     | 0.7   | 0.7   | 0.7   | 0.7   | 0.7   |
| b3-08         | Speed Estimation ACR P Gain      | -                | 0.5     | 0.5   | 0.5   | 0.5   | 0.5   | 0.5   |
| b3-26         | Direction Determination Level    | -                | 1000    | 1000  | 1000  | 1000  | 1000  | 1000  |
| b8-03         | Energy Saving Filter Time        | s                | 2.00    | 2.00  | 2.00  | 2.00  | 2.00  | 2.00  |
| b8-04         | Energy Saving Coefficient Value  | -                | 31.35   | 23.1  | 23.1  | 20.65 | 20.65 | 18.12 |
| C5-17 (C5-37) | Motor Inertia                    | kgm <sup>2</sup> | 0.49    | 0.90  | 0.90  | 1.10  | 1.10  | 1.90  |
| C6-02         | Carrier Frequency Selection      | -                | 1       | 7     | 1     | 7     | 1     | 7     |
| E2-01 (E4-01) | Motor Rated Current (FLA)        | A                | 190     | 260   | 260   | 260   | 260   | 260   |
| E2-02 (E4-02) | Motor Rated Slip                 | Hz               | 1.43    | 1.39  | 1.39  | 1.39  | 1.39  | 1.39  |
| E2-03 (E4-03) | Motor No-Load Current            | A                | 45.6    | 72    | 72    | 72    | 72    | 72    |
| E2-05 (E4-05) | Motor Line-to-Line Resistance    | Ω                | 0.022   | 0.023 | 0.023 | 0.023 | 0.023 | 0.023 |
| E2-06 (E4-06) | Motor Leakage Inductance         | %                | 20.5    | 20    | 20    | 20    | 20    | 20    |
| E2-10 (E4-10) | Motor Iron Loss                  | W                | 960     | 1200  | 1200  | 1200  | 1200  | 1200  |
| E5-01         | PM Motor Code Selection          | -                | 1215    | 1215  | 1216  | 1216  | FFFF  | FFFF  |
| L2-02         | Power Loss Ride Through Time     | s                | 2       | 2     | 2     | 2     | 2     | 2     |
| L2-03         | Minimum Baseblock Time           | s                | 1.3     | 1.5   | 1.5   | 1.5   | 1.5   | 1.7   |
| L2-04         | Powerloss V/f Recovery Ramp Time | s                | 1       | 1     | 1     | 1     | 1     | 1     |
| L2-05         | Undervoltage Detection Lvl (Uv1) | -                | 190     | 190   | 190   | 190   | 190   | 190   |
| L3-24         | Motor Accel Time for Inertia Cal | s                | 0.317   | 0.533 | 0.533 | 0.592 | 0.592 | 0.646 |
| L8-02         | Overheat Alarm Level             | °C               | 105     | 105   | 105   | 105   | 105   | 105   |
| L8-09         | Output Ground Fault Detection    | -                | 1       | 1     | 1     | 1     | 1     | 1     |
| L8-38         | Carrier Frequency Reduction      | -                | 2       | 2     | 2     | 2     | 2     | 2     |
| n1-01         | Hunting Prevention Selection     | -                | 2       | 2     | 2     | 2     | 2     | 2     |

Parameter List

1

## 1.21 Defaults by Drive Model and Duty Rating ND/HD

| No.           | Name                             | Unit | Default |       |       |       |       |       |
|---------------|----------------------------------|------|---------|-------|-------|-------|-------|-------|
|               |                                  |      | 2257    |       | 2313  |       | 2360  |       |
| -             | Drive Model                      | -    |         |       |       |       |       |       |
| C6-01         | Normal / Heavy Duty Selection    | -    | HD      | ND    | HD    | ND    | HD    | ND    |
|               |                                  |      | 0       | 1     | 0     | 1     | 0     | 1     |
| o2-04         | Drive Model (KVA) Selection      | Hex. | 75      |       | 76    |       | 77    |       |
| E2-11 (E4-11) | Motor Rated Power (kW)           | kW   | 55      | 75    | 75    | 90    | 90    | 110   |
| n1-03         | Hunting Prevention Time Constant | ms   | 10      | 10    | 10    | 10    | 100   | 100   |
| n5-02         | Motor Inertia Acceleration Time  | s    | 0.317   | 0.533 | 0.533 | 0.592 | 0.592 | 0.646 |

\*1 Parameters within parentheses are for motor 2.

### ◆ 400 V class

| No.           | Name                             | Unit             | Default |        |        |        |        |        |        |        |
|---------------|----------------------------------|------------------|---------|--------|--------|--------|--------|--------|--------|--------|
|               |                                  |                  | 4002    |        | 4004   |        | 4005   |        | 4007   |        |
| -             | Drive Model                      | -                |         |        |        |        |        |        |        |        |
| C6-01         | Normal / Heavy Duty Selection    | -                | HD1     | ND1    | HD1    | ND1    | HD1    | ND1    | HD1    | ND1    |
|               |                                  |                  | 0       | 1      | 0      | 1      | 0      | 1      | 0      | 1      |
| o2-04         | Drive Model (KVA) Selection      | Hex.             | 92      |        | 93     |        | 94     |        | 95     |        |
| E2-11 (E4-11) | Motor Rated Power (kW)           | kW               | 0.4     | 0.75   | 1.1    | 1.5    | 1.5    | 2.2    | 2.2    | 3.0    |
| b3-04         | V/f Gain during Speed Search     | %                | 100     | 100    | 100    | 100    | 100    | 100    | 100    | 100    |
| b3-06         | Speed Estimation Current Level 1 | -                | 0.5     | 0.5    | 0.5    | 0.5    | 0.5    | 0.5    | 0.5    | 0.5    |
| b3-08         | Speed Estimation ACR P Gain      | -                | 0.5     | 0.5    | 0.5    | 0.5    | 0.5    | 0.5    | 0.5    | 0.5    |
| b3-26         | Direction Determination Level    | -                | 1000    | 1000   | 1000   | 1000   | 1000   | 1000   | 1000   | 1000   |
| b8-03         | Energy Saving Filter Time        | s                | 0.50    | 0.50   | 0.50   | 0.50   | 0.50   | 0.50   | 0.50   | 0.50   |
| b8-04         | Energy Saving Coefficient Value  | -                | 576.4   | 447.4  | 447.4  | 338.8  | 338.8  | 313.6  | 313.6  | 265.7  |
| C5-17 (C5-37) | Motor Inertia                    | kgm <sup>2</sup> | 0.0015  | 0.0028 | 0.0028 | 0.0068 | 0.0068 | 0.0088 | 0.0088 | 0.0158 |
| C6-02         | Carrier Frequency Selection      | -                | 1       | 7      | 1      | 7      | 1      | 7      | 1      | 7      |
| E2-01 (E4-01) | Motor Rated Current (FLA)        | A                | 1       | 1.6    | 1.6    | 3.1    | 3.1    | 4.2    | 4.2    | 5.7    |
| E2-02 (E4-02) | Motor Rated Slip                 | Hz               | 2.9     | 2.6    | 2.6    | 2.5    | 2.5    | 3      | 3      | 2.7    |
| E2-03 (E4-03) | Motor No-Load Current            | A                | 0.6     | 0.8    | 0.8    | 1.4    | 1.4    | 1.5    | 1.5    | 1.9    |
| E2-05 (E4-05) | Motor Line-to-Line Resistance    | Ω                | 38.198  | 22.459 | 22.459 | 10.1   | 10.1   | 6.495  | 6.495  | 4.360  |
| E2-06 (E4-06) | Motor Leakage Inductance         | %                | 18.2    | 14.3   | 14.3   | 18.3   | 18.3   | 18.7   | 18.7   | 19     |



## 1.21 Defaults by Drive Model and Duty Rating ND/HD

| No.           | Name                             | Unit | Default |       |       |       |       |       |       |       |
|---------------|----------------------------------|------|---------|-------|-------|-------|-------|-------|-------|-------|
|               |                                  |      | 4002    |       | 4004  |       | 4005  |       | 4007  |       |
| -             | Drive Model                      | -    | HD1     | ND1   | HD1   | ND1   | HD1   | ND1   | HD1   | ND1   |
| C6-01         | Normal / Heavy Duty Selection    | -    | 0       | 1     | 0     | 1     | 0     | 1     | 0     | 1     |
| o2-04         | Drive Model (KVA) Selection      | Hex. | 92      |       | 93    |       | 94    |       | 95    |       |
| E2-11 (E4-11) | Motor Rated Power (kW)           | kW   | 0.4     | 0.75  | 1.1   | 1.5   | 1.5   | 2.2   | 2.2   | 3.0   |
| E2-10 (E4-10) | Motor Iron Loss                  | W    | 14      | 26    | 26    | 53    | 53    | 77    | 77    | 105   |
| E5-01         | PM Motor Code Selection          | -    | 1232    | 1232  | 1233  | 1233  | 1235  | 1235  | 1236  | 1236  |
| L2-02         | Power Loss Ride Through Time     | s    | 0.1     | 0.1   | 0.2   | 0.2   | 0.3   | 0.3   | 0.5   | 0.5   |
| L2-03         | Minimum Baseblock Time           | s    | 0.2     | 0.3   | 0.3   | 0.4   | 0.4   | 0.5   | 0.5   | 0.5   |
| L2-04         | Powerloss V/f Recovery Ramp Time | s    | 0.3     | 0.3   | 0.3   | 0.3   | 0.3   | 0.3   | 0.3   | 0.3   |
| L2-05         | Undervoltage Detection Lvl (Uv1) | -    | 380     | 380   | 380   | 380   | 380   | 380   | 380   | 380   |
| L3-24         | Motor Accel Time for Inertia Cal | s    | 0.178   | 0.142 | 0.142 | 0.166 | 0.166 | 0.145 | 0.145 | 0.145 |
| L8-02         | Overheat Alarm Level             | °C   | 100     | 100   | 105   | 105   | 112   | 112   | 100   | 100   |
| L8-09         | Output Ground Fault Detection    | -    | 1       | 1     | 1     | 1     | 1     | 1     | 1     | 1     |
| L8-38         | Carrier Frequency Reduction      | -    | 2       | 2     | 2     | 2     | 2     | 2     | 2     | 2     |
| n1-01         | Hunting Prevention Selection     | -    | 1       | 1     | 1     | 1     | 1     | 1     | 1     | 1     |
| n1-03         | Hunting Prevention Time Constant | ms   | 10      | 10    | 10    | 10    | 10    | 10    | 10    | 10    |
| n5-02         | Motor Inertia Acceleration Time  | s    | 0.178   | 0.142 | 0.142 | 0.166 | 0.166 | 0.145 | 0.145 | 0.145 |

\*1 Parameters within parentheses are for motor 2.

| No.           | Name                             | Unit | Default |     |      |     |      |     |      |     |
|---------------|----------------------------------|------|---------|-----|------|-----|------|-----|------|-----|
|               |                                  |      | 4009    |     | 4012 |     | 4018 |     | 4023 |     |
| -             | Drive Model                      | -    | HD1     | ND1 | HD1  | ND1 | HD1  | ND1 | HD1  | ND1 |
| C6-01         | Normal / Heavy Duty Selection    | -    | 0       | 1   | 0    | 1   | 0    | 1   | 0    | 1   |
| o2-04         | Drive Model (KVA) Selection      | Hex. | 96      |     | 97   |     | 99   |     | 9A   |     |
| E2-11 (E4-11) | Motor Rated Power (kW)           | kW   | 3.0     | 4.0 | 4.0  | 5.5 | 5.5  | 7.5 | 7.5  | 11  |
| b3-04         | V/f Gain during Speed Search     | %    | 100     | 100 | 100  | 100 | 100  | 100 | 100  | 100 |
| b3-06         | Speed Estimation Current Level 1 | -    | 0.5     | 0.5 | 0.5  | 0.5 | 0.5  | 0.5 | 0.5  | 0.5 |

Parameter List

1

## 1.21 Defaults by Drive Model and Duty Rating ND/HD

| No.           | Name                             | Unit             | Default |        |        |        |       |        |        |        |
|---------------|----------------------------------|------------------|---------|--------|--------|--------|-------|--------|--------|--------|
|               |                                  |                  | 4009    |        | 4012   |        | 4018  |        | 4023   |        |
| -             | Drive Model                      | -                | HD1     | ND1    | HD1    | ND1    | HD1   | ND1    | HD1    | ND1    |
| C6-01         | Normal / Heavy Duty Selection    | -                | 0       | 1      | 0      | 1      | 0     | 1      | 0      | 1      |
| o2-04         | Drive Model (KVA) Selection      | Hex.             | 96      |        | 97     |        | 99    |        | 9A     |        |
| E2-11 (E4-11) | Motor Rated Power (kW)           | kW               | 3.0     | 4.0    | 4.0    | 5.5    | 5.5   | 7.5    | 7.5    | 11     |
| b3-08         | Speed Estimation ACR P Gain      | -                | 0.5     | 0.5    | 0.5    | 0.5    | 0.5   | 0.5    | 0.5    | 0.5    |
| b3-26         | Direction Determination Level    | -                | 1000    | 1000   | 1000   | 1000   | 1000  | 1000   | 1000   | 1000   |
| b8-03         | Energy Saving Filter Time        | s                | 0.50    | 0.50   | 0.50   | 0.50   | 0.50  | 0.50   | 0.50   | 0.50   |
| b8-04         | Energy Saving Coefficient Value  | -                | 265.7   | 245.8  | 245.8  | 189.5  | 189.5 | 145.38 | 145.38 | 140.88 |
| C5-17 (C5-37) | Motor Inertia                    | kgm <sup>2</sup> | 0.0158  | 0.0158 | 0.0158 | 0.0255 | 0.026 | 0.037  | 0.037  | 0.053  |
| C6-02         | Carrier Frequency Selection      | -                | 1       | 7      | 1      | 7      | 1     | 7      | 1      | 7      |
| E2-01 (E4-01) | Motor Rated Current (FLA)        | A                | 5.7     | 7      | 7      | 9.8    | 9.8   | 13.3   | 13.3   | 19.9   |
| E2-02 (E4-02) | Motor Rated Slip                 | Hz               | 2.7     | 2.7    | 2.7    | 1.5    | 1.5   | 1.3    | 1.3    | 1.7    |
| E2-03 (E4-03) | Motor No-Load Current            | A                | 1.9     | 2.3    | 2.3    | 2.6    | 2.6   | 4      | 4      | 5.6    |
| E2-05 (E4-05) | Motor Line-to-Line Resistance    | Ω                | 4.360   | 3.333  | 3.333  | 1.595  | 1.595 | 1.152  | 1.152  | 0.922  |
| E2-06 (E4-06) | Motor Leakage Inductance         | %                | 19      | 19.3   | 19.3   | 18.2   | 18.2  | 15.5   | 15.5   | 19.6   |
| E2-10 (E4-10) | Motor Iron Loss                  | W                | 105     | 130    | 130    | 193    | 193   | 263    | 263    | 385    |
| E5-01         | PM Motor Code Selection          | -                | FFFF    | FFFF   | 1238   | 1238   | 123A  | 123A   | 123B   | 123B   |
| L2-02         | Power Loss Ride Through Time     | s                | 0.5     | 0.5    | 0.5    | 0.5    | 0.8   | 0.8    | 1      | 1      |
| L2-03         | Minimum Baseblock Time           | s                | 0.5     | 0.6    | 0.6    | 0.7    | 0.7   | 0.8    | 0.8    | 0.9    |
| L2-04         | Powerloss V/f Recovery Ramp Time | s                | 0.3     | 0.3    | 0.3    | 0.3    | 0.3   | 0.3    | 0.3    | 0.3    |
| L2-05         | Undervoltage Detection Lvl (Uv1) | -                | 380     | 380    | 380    | 380    | 380   | 380    | 380    | 380    |
| L3-24         | Motor Accel Time for Inertia Cal | s                | 0.145   | 0.154  | 0.154  | 0.168  | 0.168 | 0.175  | 0.175  | 0.265  |
| L8-02         | Overheat Alarm Level             | °C               | 100     | 100    | 100    | 100    | 105   | 105    | 105    | 105    |
| L8-09         | Output Ground Fault Detection    | -                | 1       | 1      | 1      | 1      | 1     | 1      | 1      | 1      |
| L8-38         | Carrier Frequency Reduction      | -                | 2       | 2      | 2      | 2      | 2     | 2      | 2      | 2      |

## 1.21 Defaults by Drive Model and Duty Rating ND/HD

| No.           | Name                             | Unit | Default |       |       |       |       |       |       |       |
|---------------|----------------------------------|------|---------|-------|-------|-------|-------|-------|-------|-------|
|               |                                  |      | 4009    |       | 4012  |       | 4018  |       | 4023  |       |
| -             | Drive Model                      | -    | HD1     | ND1   | HD1   | ND1   | HD1   | ND1   | HD1   | ND1   |
| C6-01         | Normal / Heavy Duty Selection    | -    | 0       | 1     | 0     | 1     | 0     | 1     | 0     | 1     |
| o2-04         | Drive Model (KVA) Selection      | Hex. | 96      |       | 97    |       | 99    |       | 9A    |       |
| E2-11 (E4-11) | Motor Rated Power (kW)           | kW   | 3.0     | 4.0   | 4.0   | 5.5   | 5.5   | 7.5   | 7.5   | 11    |
| n1-01         | Hunting Prevention Selection     | -    | 1       | 1     | 1     | 1     | 1     | 1     | 1     | 1     |
| n1-03         | Hunting Prevention Time Constant | ms   | 10      | 10    | 10    | 10    | 10    | 10    | 10    | 10    |
| n5-02         | Motor Inertia Acceleration Time  | s    | 0.145   | 0.154 | 0.154 | 0.168 | 0.168 | 0.175 | 0.175 | 0.265 |

\*1 Parameters within parentheses are for motor 2.

| No.           | Name                             | Unit             | Default |        |        |        |        |        |        |       |
|---------------|----------------------------------|------------------|---------|--------|--------|--------|--------|--------|--------|-------|
|               |                                  |                  | 4031    |        | 4038   |        | 4044   |        | 4060   |       |
| -             | Drive Model                      | -                | HD1     | ND1    | HD1    | ND1    | HD1    | ND1    | HD1    | ND1   |
| C6-01         | Normal / Heavy Duty Selection    | -                | 0       | 1      | 0      | 1      | 0      | 1      | 0      | 1     |
| o2-04         | Drive Model (KVA) Selection      | Hex.             | 9C      |        | 9D     |        | 9E     |        |        |       |
| E2-11 (E4-11) | Motor Rated Power (kW)           | kW               | 11      | 15     | 15     | 18.5   | 18.5   | 22     | 22     | 30    |
| b3-04         | V/f Gain during Speed Search     | %                | 100     | 100    | 100    | 100    | 100    | 100    | 100    | 100   |
| b3-06         | Speed Estimation Current Level 1 | -                | 0.5     | 0.5    | 0.5    | 0.5    | 0.5    | 0.5    | 0.5    | 0.5   |
| b3-08         | Speed Estimation ACR P Gain      | -                | 0.5     | 0.5    | 0.5    | 0.5    | 0.5    | 0.5    | 0.5    | 0.5   |
| b3-26         | Direction Determination Level    | -                | 1000    | 1000   | 1000   | 1000   | 1000   | 1000   | 1000   | 1000  |
| b8-03         | Energy Saving Filter Time        | s                | 0.50    | 0.50   | 0.50   | 0.50   | 0.50   | 0.50   | 0.50   | 0.50  |
| b8-04         | Energy Saving Coefficient Value  | -                | 140.88  | 126.26 | 126.26 | 115.74 | 115.74 | 103.58 | 103.58 | 92.54 |
| C5-17 (C5-37) | Motor Inertia                    | kgm <sup>2</sup> | 0.053   | 0.076  | 0.076  | 0.138  | 0.138  | 0.165  | 0.165  | 0.220 |
| C6-02         | Carrier Frequency Selection      | -                | 1       | 7      | 1      | 7      | 1      | 7      | 1      | 7     |
| E2-01 (E4-01) | Motor Rated Current (FLA)        | A                | 19.9    | 26.5   | 26.5   | 32.9   | 32.9   | 38.6   | 38.6   | 52.3  |
| E2-02 (E4-02) | Motor Rated Slip                 | Hz               | 1.7     | 1.6    | 1.6    | 1.67   | 1.67   | 1.7    | 1.7    | 1.8   |
| E2-03 (E4-03) | Motor No-Load Current            | A                | 5.6     | 7.6    | 7.6    | 7.8    | 7.8    | 9.2    | 9.2    | 10.9  |
| E2-05 (E4-05) | Motor Line-to-Line Resistance    | Ω                | 0.922   | 0.55   | 0.55   | 0.403  | 0.403  | 0.316  | 0.316  | 0.269 |

Parameter List

1

## 1.21 Defaults by Drive Model and Duty Rating ND/HD

| No.           | Name                             | Unit | Default |       |       |       |       |       |       |       |
|---------------|----------------------------------|------|---------|-------|-------|-------|-------|-------|-------|-------|
|               |                                  |      | 4031    |       | 4038  |       | 4044  |       | 4060  |       |
| -             | Drive Model                      | -    | HD1     | ND1   | HD1   | ND1   | HD1   | ND1   | HD1   | ND1   |
| C6-01         | Normal / Heavy Duty Selection    | -    | 0       | 1     | 0     | 1     | 0     | 1     | 0     | 1     |
| o2-04         | Drive Model (KVA) Selection      | Hex. | 9C      |       | 9D    |       | 9E    |       |       |       |
| E2-11 (E4-11) | Motor Rated Power (kW)           | kW   | 11      | 15    | 15    | 18.5  | 18.5  | 22    | 22    | 30    |
| E2-06 (E4-06) | Motor Leakage Inductance         | %    | 19.6    | 17.2  | 17.2  | 20.1  | 20.1  | 23.5  | 23.5  | 20.7  |
| E2-10 (E4-10) | Motor Iron Loss                  | W    | 385     | 440   | 440   | 508   | 508   | 586   | 586   | 750   |
| E5-01         | PM Motor Code Selection          | -    | 123D    | 123D  | 123E  | 123E  | 123F  | 123F  | 1240  | 1240  |
| L2-02         | Power Loss Ride Through Time     | s    | 2       | 2     | 2     | 2     | 2     | 2     | 2     | 2     |
| L2-03         | Minimum Baseblock Time           | s    | 0.9     | 1     | 1     | 1     | 1     | 1     | 1     | 1.1   |
| L2-04         | Powerloss V/f Recovery Ramp Time | s    | 0.3     | 0.6   | 0.6   | 0.6   | 0.6   | 0.6   | 0.6   | 0.6   |
| L2-05         | Undervoltage Detection Lvl (Uv1) | -    | 380     | 380   | 380   | 380   | 380   | 380   | 380   | 380   |
| L3-24         | Motor Accel Time for Inertia Cal | s    | 0.265   | 0.244 | 0.244 | 0.317 | 0.317 | 0.355 | 0.355 | 0.323 |
| L8-02         | Overheat Alarm Level             | °C   | 115     | 115   | 120   | 120   | 120   | 120   | 130   | 137   |
| L8-09         | Output Ground Fault Detection    | -    | 1       | 1     | 1     | 1     | 1     | 1     | 1     | 1     |
| L8-38         | Carrier Frequency Reduction      | -    | 2       | 2     | 2     | 2     | 2     | 2     | 2     | 2     |
| n1-01         | Hunting Prevention Selection     | -    | 2       | 2     | 2     | 2     | 2     | 2     | 2     | 2     |
| n1-03         | Hunting Prevention Time Constant | ms   | 10      | 10    | 10    | 10    | 10    | 10    | 10    | 10    |
| n5-02         | Motor Inertia Acceleration Time  | s    | 0.265   | 0.244 | 0.244 | 0.317 | 0.317 | 0.355 | 0.355 | 0.323 |

\*1 Parameters within parentheses are for motor 2.

## 1.21 Defaults by Drive Model and Duty Rating ND/HD

| No.           | Name                             | Unit             | Default |       |       |       |       |       |       |       |
|---------------|----------------------------------|------------------|---------|-------|-------|-------|-------|-------|-------|-------|
|               |                                  |                  | 4075    |       | 4089  |       | 4103  |       | 4140  |       |
| -             | Drive Model                      | -                | HD1     | ND1   | HD1   | ND1   | HD1   | ND1   | HD1   | ND1   |
| C6-01         | Normal / Heavy Duty Selection    | -                | 0       | 1     | 0     | 1     | 0     | 1     | 0     | 1     |
| o2-04         | Drive Model (KVA) Selection      | Hex.             | A1      |       | A2    |       | A3    |       | A4    |       |
| E2-11 (E4-11) | Motor Rated Power (kW)           | kW               | 30      | 37    | 37    | 45    | 45    | 55    | 55    | 75    |
| b3-04         | V/f Gain during Speed Search     | %                | 100     | 100   | 100   | 100   | 100   | 80    | 80    | 60    |
| b3-06         | Speed Estimation Current Level 1 | -                | 0.5     | 0.5   | 0.5   | 0.5   | 0.5   | 0.5   | 0.5   | 0.7   |
| b3-08         | Speed Estimation ACR P Gain      | -                | 0.5     | 0.5   | 0.5   | 0.5   | 0.5   | 0.5   | 0.5   | 0.8   |
| b3-26         | Direction Determination Level    | -                | 1000    | 1000  | 1000  | 1000  | 1000  | 1000  | 1000  | 1000  |
| b8-03         | Energy Saving Filter Time        | s                | 0.50    | 0.50  | 0.50  | 0.50  | 0.50  | 2.00  | 2.00  | 2.00  |
| b8-04         | Energy Saving Coefficient Value  | -                | 92.54   | 76.32 | 76.32 | 71.56 | 71.56 | 67.2  | 67.2  | 46.2  |
| C5-17 (C5-37) | Motor Inertia                    | kgm <sup>2</sup> | 0.220   | 0.273 | 0.273 | 0.333 | 0.333 | 0.490 | 0.49  | 0.90  |
| C6-02         | Carrier Frequency Selection      | -                | 1       | 7     | 1     | 7     | 1     | 7     | 1     | 7     |
| E2-01 (E4-01) | Motor Rated Current (FLA)        | A                | 52.3    | 65.6  | 65.6  | 79.7  | 79.7  | 95    | 95    | 130   |
| E2-02 (E4-02) | Motor Rated Slip                 | Hz               | 1.8     | 1.33  | 1.33  | 1.6   | 1.6   | 1.46  | 1.46  | 1.39  |
| E2-03 (E4-03) | Motor No-Load Current            | A                | 10.9    | 19.1  | 19.1  | 22    | 22    | 24    | 24    | 36    |
| E2-05 (E4-05) | Motor Line-to-Line Resistance    | Ω                | 0.269   | 0.155 | 0.155 | 0.122 | 0.122 | 0.088 | 0.088 | 0.092 |
| E2-06 (E4-06) | Motor Leakage Inductance         | %                | 20.7    | 18.8  | 18.8  | 19.9  | 19.9  | 20    | 20    | 20    |
| E2-10 (E4-10) | Motor Iron Loss                  | W                | 750     | 925   | 925   | 1125  | 1125  | 1260  | 1260  | 1600  |
| E5-01         | PM Motor Code Selection          | -                | 1242    | 1242  | 1243  | 1243  | 1244  | 1244  | 1245  | 1245  |
| L2-02         | Power Loss Ride Through Time     | s                | 2       | 2     | 2     | 2     | 2     | 2     | 2     | 2     |
| L2-03         | Minimum Baseblock Time           | s                | 1.1     | 1.1   | 1.1   | 1.2   | 1.2   | 1.2   | 1.2   | 1.3   |
| L2-04         | Powerloss V/f Recovery Ramp Time | s                | 0.6     | 0.6   | 0.6   | 0.6   | 0.6   | 1     | 1     | 1     |
| L2-05         | Undervoltage Detection Lvl (Uv1) | -                | 380     | 380   | 380   | 380   | 380   | 380   | 380   | 380   |
| L3-24         | Motor Accel Time for Inertia Cal | s                | 0.323   | 0.32  | 0.32  | 0.387 | 0.387 | 0.317 | 0.317 | 0.533 |
| L8-02         | Overheat Alarm Level             | °C               | 120     | 120   | 115   | 115   | 126   | 120   | 120   | 120   |

Parameter List

## 1.21 Defaults by Drive Model and Duty Rating ND/HD

| No.           | Name                             | Unit | Default |      |      |       |       |       |       |       |
|---------------|----------------------------------|------|---------|------|------|-------|-------|-------|-------|-------|
|               |                                  |      | 4075    |      | 4089 |       | 4103  |       | 4140  |       |
| -             | Drive Model                      | -    | HD1     | ND1  | HD1  | ND1   | HD1   | ND1   | HD1   | ND1   |
| C6-01         | Normal / Heavy Duty Selection    | -    | 0       | 1    | 0    | 1     | 0     | 1     | 0     | 1     |
| o2-04         | Drive Model (KVA) Selection      | Hex. | A1      |      | A2   |       | A3    |       | A4    |       |
| E2-11 (E4-11) | Motor Rated Power (kW)           | kW   | 30      | 37   | 37   | 45    | 45    | 55    | 55    | 75    |
| L8-09         | Output Ground Fault Detection    | -    | 1       | 1    | 1    | 1     | 1     | 1     | 1     | 1     |
| L8-38         | Carrier Frequency Reduction      | -    | 2       | 2    | 2    | 2     | 2     | 2     | 2     | 2     |
| n1-01         | Hunting Prevention Selection     | -    | 2       | 2    | 2    | 2     | 2     | 2     | 2     | 2     |
| n1-03         | Hunting Prevention Time Constant | ms   | 10      | 10   | 10   | 10    | 10    | 10    | 30    | 30    |
| n5-02         | Motor Inertia Acceleration Time  | s    | 0.323   | 0.32 | 0.32 | 0.387 | 0.387 | 0.317 | 0.317 | 0.533 |

\*1 Parameters within parentheses are for motor 2.

| No.           | Name                             | Unit             | Default |       |       |       |       |       |       |       |
|---------------|----------------------------------|------------------|---------|-------|-------|-------|-------|-------|-------|-------|
|               |                                  |                  | 4168    |       | 4208  |       | 4250  |       | 4302  |       |
| -             | Drive Model                      | -                | HD1     | ND1   | HD1   | ND1   | HD1   | ND1   | HD1   | ND1   |
| C6-01         | Normal / Heavy Duty Selection    | -                | 0       | 1     | 0     | 1     | 0     | 1     | 0     | 1     |
| o2-04         | Drive Model (KVA) Selection      | Hex.             | A5      |       | A6    |       | A7    |       | A8    |       |
| E2-11 (E4-11) | Motor Rated Power (kW)           | kW               | 75      | 90    | 90    | 110   | 110   | 132   | 132   | 160   |
| b3-04         | V/f Gain during Speed Search     | %                | 60      | 60    | 60    | 60    | 60    | 60    | 60    | 60    |
| b3-06         | Speed Estimation Current Level 1 | -                | 0.7     | 0.7   | 0.7   | 0.7   | 0.7   | 0.7   | 0.7   | 0.7   |
| b3-08         | Speed Estimation ACR P Gain      | -                | 0.8     | 0.8   | 0.8   | 0.8   | 0.8   | 0.8   | 0.8   | 0.8   |
| b3-26         | Direction Determination Level    | -                | 1000    | 1000  | 1000  | 1000  | 1000  | 1000  | 1000  | 1000  |
| b8-03         | Energy Saving Filter Time        | s                | 2.00    | 2.00  | 2.00  | 2.00  | 2.00  | 2.00  | 2.00  | 2.00  |
| b8-04         | Energy Saving Coefficient Value  | -                | 46.2    | 38.91 | 38.91 | 36.23 | 36.23 | 32.79 | 32.79 | 30.13 |
| C5-17 (C5-37) | Motor Inertia                    | kgm <sup>2</sup> | 0.90    | 1.10  | 1.10  | 1.90  | 1.90  | 2.10  | 2.10  | 3.30  |
| C6-02         | Carrier Frequency Selection      | -                | 1       | 7     | 1     | 7     | 1     | 7     | 1     | 7     |
| E2-01 (E4-01) | Motor Rated Current (FLA)        | A                | 130     | 156   | 156   | 190   | 190   | 223   | 223   | 270   |
| E2-02 (E4-02) | Motor Rated Slip                 | Hz               | 1.39    | 1.4   | 1.4   | 1.4   | 1.4   | 1.38  | 1.38  | 1.35  |

## 1.21 Defaults by Drive Model and Duty Rating ND/HD

| No.           | Name                             | Unit | Default |       |       |       |       |       |       |       |
|---------------|----------------------------------|------|---------|-------|-------|-------|-------|-------|-------|-------|
|               |                                  |      | 4168    |       | 4208  |       | 4250  |       | 4302  |       |
| -             | Drive Model                      | -    | HD1     | ND1   | HD1   | ND1   | HD1   | ND1   | HD1   | ND1   |
| C6-01         | Normal / Heavy Duty Selection    | -    | 0       | 1     | 0     | 1     | 0     | 1     | 0     | 1     |
| o2-04         | Drive Model (KVA) Selection      | Hex. | A5      |       | A6    |       | A7    |       | A8    |       |
| E2-11 (E4-11) | Motor Rated Power (kW)           | kW   | 75      | 90    | 90    | 110   | 110   | 132   | 132   | 160   |
| E2-03 (E4-03) | Motor No-Load Current            | A    | 36      | 40    | 40    | 49    | 49    | 58    | 58    | 70    |
| E2-05 (E4-05) | Motor Line-to-Line Resistance    | Ω    | 0.092   | 0.056 | 0.056 | 0.046 | 0.046 | 0.035 | 0.035 | 0.029 |
| E2-06 (E4-06) | Motor Leakage Inductance         | %    | 20      | 20    | 20    | 20    | 20    | 20    | 20    | 20    |
| E2-10 (E4-10) | Motor Iron Loss                  | W    | 1600    | 1760  | 1760  | 2150  | 2150  | 2350  | 2350  | 2850  |
| E5-01         | PM Motor Code Selection          | -    | 1246    | 1246  | 1247  | 1247  | 1248  | 1248  | 1249  | 1249  |
| L2-02         | Power Loss Ride Through Time     | s    | 2       | 2     | 2     | 2     | 2     | 2     | 2     | 2     |
| L2-03         | Minimum Baseblock Time           | s    | 1.3     | 1.5   | 1.5   | 1.7   | 1.7   | 1.7   | 1.7   | 1.8   |
| L2-04         | Powerloss V/f Recovery Ramp Time | s    | 1       | 1     | 1     | 1     | 1     | 1     | 1     | 1     |
| L2-05         | Undervoltage Detection Lvl (Uv1) | -    | 380     | 380   | 380   | 380   | 380   | 380   | 380   | 380   |
| L3-24         | Motor Accel Time for Inertia Cal | s    | 0.533   | 0.592 | 0.592 | 0.646 | 0.646 | 0.673 | 0.673 | 0.777 |
| L8-02         | Overheat Alarm Level             | °C   | 110     | 110   | 105   | 105   | 120   | 120   | 120   | 120   |
| L8-09         | Output Ground Fault Detection    | -    | 1       | 1     | 1     | 1     | 1     | 1     | 1     | 1     |
| L8-38         | Carrier Frequency Reduction      | -    | 2       | 2     | 2     | 2     | 2     | 2     | 2     | 2     |
| n1-01         | Hunting Prevention Selection     | -    | 2       | 2     | 2     | 2     | 2     | 2     | 2     | 2     |
| n1-03         | Hunting Prevention Time Constant | ms   | 30      | 30    | 30    | 30    | 30    | 30    | 30    | 30    |
| n5-02         | Motor Inertia Acceleration Time  | s    | 0.533   | 0.592 | 0.592 | 0.646 | 0.646 | 0.673 | 0.673 | 0.777 |

\*1 Parameters within parentheses are for motor 2.

Parameter List

## 1.21 Defaults by Drive Model and Duty Rating ND/HD

| No.           | Name                             | Unit             | Default |       |       |       |       |       |       |       |
|---------------|----------------------------------|------------------|---------|-------|-------|-------|-------|-------|-------|-------|
|               |                                  |                  | 4371    |       | 4414  |       | 4477  |       | 4568  |       |
| -             | Drive Model                      | -                | HD1     | ND1   | HD1   | ND1   | HD1   | ND1   | HD1   | ND1   |
| C6-01         | Normal / Heavy Duty Selection    | -                | 0       | 1     | 0     | 1     | 0     | 1     | 0     | 1     |
| o2-04         | Drive Model (KVA) Selection      | Hex.             | A9      |       | AA    |       | AC    |       | AD    |       |
| E2-11 (E4-11) | Motor Rated Power (kW)           | kW               | 160     | 200   | 200   | 220   | 220   | 250   | 250   | 315   |
| b3-04         | V/f Gain during Speed Search     | %                | 60      | 60    | 60    | 60    | 60    | 60    | 60    | 60    |
| b3-06         | Speed Estimation Current Level 1 | -                | 0.7     | 0.7   | 0.7   | 0.7   | 0.7   | 0.7   | 0.7   | 0.7   |
| b3-08         | Speed Estimation ACR P Gain      | -                | 0.8     | 0.8   | 0.8   | 0.8   | 0.8   | 0.8   | 0.8   | 0.8   |
| b3-26         | Direction Determination Level    | -                | 1000    | 1000  | 1000  | 1000  | 1000  | 1000  | 1000  | 1000  |
| b8-03         | Energy Saving Filter Time        | s                | 2.00    | 2.00  | 2.00  | 2.00  | 2.00  | 2.00  | 2.00  | 2.00  |
| b8-04         | Energy Saving Coefficient Value  | -                | 30.13   | 30.57 | 30.57 | 27.13 | 27.13 | 21.76 | 21.76 | 21.76 |
| C5-17 (C5-37) | Motor Inertia                    | kgm <sup>2</sup> | 3.30    | 3.60  | 3.60  | 4.10  | 4.10  | 6.50  | 6.50  | 11.00 |
| C6-02         | Carrier Frequency Selection      | -                | 1       | 7     | 1     | 7     | 1     | 7     | 1     | 7     |
| E2-01 (E4-01) | Motor Rated Current (FLA)        | A                | 270     | 310   | 310   | 370   | 370   | 500   | 500   | 500   |
| E2-02 (E4-02) | Motor Rated Slip                 | Hz               | 1.35    | 1.3   | 1.3   | 1.3   | 1.3   | 1.25  | 1.25  | 1.25  |
| E2-03 (E4-03) | Motor No-Load Current            | A                | 70      | 81    | 81    | 96    | 96    | 130   | 130   | 130   |
| E2-05 (E4-05) | Motor Line-to-Line Resistance    | Ω                | 0.029   | 0.025 | 0.025 | 0.02  | 0.02  | 0.014 | 0.014 | 0.014 |
| E2-06 (E4-06) | Motor Leakage Inductance         | %                | 20      | 20    | 20    | 20    | 20    | 20    | 20    | 20    |
| E2-10 (E4-10) | Motor Iron Loss                  | W                | 2850    | 3200  | 3200  | 3700  | 3700  | 4700  | 4700  | 4700  |
| E5-01         | PM Motor Code Selection          | -                | 124A    | 124A  | 124A  | 124A  | 124A  | 124A  | 124A  | 124A  |
| L2-02         | Power Loss Ride Through Time     | s                | 2       | 2     | 2     | 2     | 2     | 2     | 2     | 2     |
| L2-03         | Minimum Baseblock Time           | s                | 1.8     | 1.9   | 1.9   | 2     | 2     | 2.1   | 2.1   | 2.1   |
| L2-04         | Powerloss V/f Recovery Ramp Time | s                | 1       | 1     | 1.8   | 1.8   | 1.8   | 2     | 2     | 2     |
| L2-05         | Undervoltage Detection Lvl (Uv1) | -                | 380     | 380   | 380   | 380   | 380   | 380   | 380   | 380   |
| L3-24         | Motor Accel Time for Inertia Cal | s                | 0.777   | 0.864 | 0.864 | 0.91  | 0.91  | 1.392 | 1.392 | 1.392 |
| L8-02         | Overheat Alarm Level             | °C               | 125     | 125   | 125   | 125   | 110   | 110   | 125   | 115   |



## 1.21 Defaults by Drive Model and Duty Rating ND/HD

| No.           | Name                             | Unit | Default |       |       |      |      |       |       |       |
|---------------|----------------------------------|------|---------|-------|-------|------|------|-------|-------|-------|
|               |                                  |      | 4371    |       | 4414  |      | 4477 |       | 4568  |       |
| -             | Drive Model                      | -    | HD1     | ND1   | HD1   | ND1  | HD1  | ND1   | HD1   | ND1   |
| C6-01         | Normal / Heavy Duty Selection    | -    | 0       | 1     | 0     | 1    | 0    | 1     | 0     | 1     |
| o2-04         | Drive Model (KVA) Selection      | Hex. | A9      |       | AA    |      | AC   |       | AD    |       |
| E2-11 (E4-11) | Motor Rated Power (kW)           | kW   | 160     | 200   | 200   | 220  | 220  | 250   | 250   | 315   |
| L8-09         | Output Ground Fault Detection    | -    | 1       | 1     | 1     | 1    | 1    | 1     | 1     | 1     |
| L8-38         | Carrier Frequency Reduction      | -    | 2       | 2     | 2     | 2    | 2    | 2     | 2     | 2     |
| n1-01         | Hunting Prevention Selection     | -    | 2       | 2     | 2     | 2    | 2    | 2     | 2     | 2     |
| n1-03         | Hunting Prevention Time Constant | ms   | 30      | 30    | 100   | 100  | 100  | 100   | 100   | 100   |
| n5-02         | Motor Inertia Acceleration Time  | s    | 0.777   | 0.864 | 0.864 | 0.91 | 0.91 | 1.392 | 1.392 | 1.392 |

\*1 Parameters within parentheses are for motor 2.

| No.           | Name                             | Unit             | Default |       |       |       |
|---------------|----------------------------------|------------------|---------|-------|-------|-------|
|               |                                  |                  | 4605    |       | 4720  |       |
| -             | Drive Model                      | -                | HD1     | ND1   | HD1   | ND1   |
| C6-01         | Normal / Heavy Duty Selection    | -                | 0       | 1     | 0     | 1     |
| o2-04         | Drive Model (KVA) Selection      | Hex.             | AE      |       | AF    |       |
| E2-11 (E4-11) | Motor Rated Power (kW)           | kW               | 315     | 355   | 315   | 370   |
| b3-04         | V/f Gain during Speed Search     | %                | 60      | 60    | 60    | 60    |
| b3-06         | Speed Estimation Current Level 1 | -                | 0.7     | 0.7   | 0.7   | 0.7   |
| b3-08         | Speed Estimation ACR P Gain      | -                | 0.8     | 0.8   | 0.8   | 0.8   |
| b3-26         | Direction Determination Level    | -                | 1000    | 1000  | 1000  | 1000  |
| b8-03         | Energy Saving Filter Time        | s                | 2.00    | 2.00  | 2.00  | 2.00  |
| b8-04         | Energy Saving Coefficient Value  | -                | 21.76   | 23.84 | 21.76 | 23.84 |
| C5-17 (C5-37) | Motor Inertia                    | kgm <sup>2</sup> | 11.00   | 12.00 | 11.00 | 12.00 |
| C6-02         | Carrier Frequency Selection      | -                | 1       | 7     | 1     | 7     |
| E2-01 (E4-01) | Motor Rated Current (FLA)        | A                | 500     | 650   | 500   | 650   |
| E2-02 (E4-02) | Motor Rated Slip                 | Hz               | 1.25    | 1     | 1.25  | 1     |
| E2-03 (E4-03) | Motor No-Load Current            | A                | 130     | 130   | 130   | 130   |
| E2-05 (E4-05) | Motor Line-to-Line Resistance    | Ω                | 0.014   | 0.012 | 0.014 | 0.012 |
| E2-06 (E4-06) | Motor Leakage Inductance         | %                | 20      | 20    | 20    | 20    |

Parameter List

1

## 1.21 Defaults by Drive Model and Duty Rating ND/HD

| No.           | Name                             | Unit | Default |       |       |       |
|---------------|----------------------------------|------|---------|-------|-------|-------|
|               |                                  |      | 4605    |       | 4720  |       |
| -             | Drive Model                      | -    |         |       |       |       |
| C6-01         | Normal / Heavy Duty Selection    | -    | HD1     | ND1   | HD1   | ND1   |
|               |                                  |      | 0       | 1     | 0     | 1     |
| o2-04         | Drive Model (KVA) Selection      | Hex. | AE      |       | AF    |       |
| E2-11 (E4-11) | Motor Rated Power (kW)           | kW   | 315     | 355   | 315   | 370   |
| E2-10 (E4-10) | Motor Iron Loss                  | W    | 4700    | 5560  | 4700  | 5560  |
| E5-01         | PM Motor Code Selection          | -    | FFFF    | FFFF  | FFFF  | FFFF  |
| L2-02         | Power Loss Ride Through Time     | s    | 2       | 2     | 2     | 2     |
| L2-03         | Minimum Baseblock Time           | s    | 2.1     | 2.3   | 2.1   | 2.3   |
| L2-04         | Powerloss V/f Recovery Ramp Time | s    | 2       | 2.2   | 2     | 2.2   |
| L2-05         | Undervoltage Detection Lvl (Uv1) | -    | 380     | 380   | 380   | 380   |
| L3-24         | Motor Accel Time for Inertia Cal | s    | 1.392   | 1.667 | 1.392 | 1.667 |
| L8-02         | Overheat Alarm Level             | °C   | 133     | 133   | 125   | 125   |
| L8-09         | Output Ground Fault Detection    | -    | 1       | 1     | 1     | 1     |
| L8-38         | Carrier Frequency Reduction      | -    | 2       | 2     | 2     | 2     |
| n1-01         | Hunting Prevention Selection     | -    | 2       | 2     | 2     | 2     |
| n1-03         | Hunting Prevention Time Constant | ms   | 100     | 100   | 100   | 100   |
| n5-02         | Motor Inertia Acceleration Time  | s    | 1.392   | 1.667 | 1.392 | 1.667 |

\*1 Parameters within parentheses are for motor 2.

### ◆ 400 V class

| No. */        | Name                             | Unit | Default |      |      |      |      |      |      |      |
|---------------|----------------------------------|------|---------|------|------|------|------|------|------|------|
|               |                                  |      | 4002    |      | 4004 |      | 4005 |      | 4007 |      |
| -             | Drive Model                      | -    |         |      |      |      |      |      |      |      |
| C6-01         | Normal / Heavy Duty Selection    | -    | HD2     | ND2  | HD2  | ND2  | HD2  | ND2  | HD2  | ND2  |
|               |                                  |      | 0       | 1    | 0    | 1    | 0    | 1    | 0    | 1    |
| o2-04         | Drive Model (KVA) Selection      | Hex. | 92      |      | 93   |      | 94   |      | 95   |      |
| E2-11 (E4-11) | Motor Rated Power (kW)           | kW   | 0.4     | 0.75 | 1.1  | 1.5  | 1.5  | 2.2  | 2.2  | 3.0  |
| b3-04         | V/f Gain during Speed Search     | %    | 100     | 100  | 100  | 100  | 100  | 100  | 100  | 100  |
| b3-06         | Speed Estimation Current Level 1 | -    | 0.5     | 0.5  | 0.5  | 0.5  | 0.5  | 0.5  | 0.5  | 0.5  |
| b3-08         | Speed Estimation ACR P Gain      | -    | 0.5     | 0.5  | 0.5  | 0.5  | 0.5  | 0.5  | 0.5  | 0.5  |
| b3-26         | Direction Determination Level    | -    | 1000    | 1000 | 1000 | 1000 | 1000 | 1000 | 1000 | 1000 |

## 1.21 Defaults by Drive Model and Duty Rating ND/HD

| No. */        | Name                             | Unit             | Default |        |        |        |        |        |        |        |
|---------------|----------------------------------|------------------|---------|--------|--------|--------|--------|--------|--------|--------|
|               |                                  |                  | 4002    |        | 4004   |        | 4005   |        | 4007   |        |
| -             | Drive Model                      | -                | HD2     | ND2    | HD2    | ND2    | HD2    | ND2    | HD2    | ND2    |
| C6-01         | Normal / Heavy Duty Selection    | -                | 0       | 1      | 0      | 1      | 0      | 1      | 0      | 1      |
| o2-04         | Drive Model (KVA) Selection      | Hex.             | 92      |        | 93     |        | 94     |        | 95     |        |
| E2-11 (E4-11) | Motor Rated Power (kW)           | kW               | 0.4     | 0.75   | 1.1    | 1.5    | 1.5    | 2.2    | 2.2    | 3.0    |
| b8-03         | Energy Saving Filter Time        | s                | 0.50    | 0.50   | 0.50   | 0.50   | 0.50   | 0.50   | 0.50   | 0.50   |
| b8-04         | Energy Saving Coefficient Value  | -                | 576.4   | 447.4  | 447.4  | 338.8  | 338.8  | 313.6  | 313.6  | 265.7  |
| C5-17 (C5-37) | Motor Inertia                    | kgm <sup>2</sup> | 0.0015  | 0.0028 | 0.0028 | 0.0068 | 0.0068 | 0.0088 | 0.0088 | 0.0158 |
| C6-02         | Carrier Frequency Selection      | -                | 1       | 7      | 1      | 7      | 1      | 7      | 1      | 7      |
| E2-01 (E4-01) | Motor Rated Current (FLA)        | A                | 1       | 1.6    | 1.6    | 3.1    | 3.1    | 4.2    | 4.2    | 5.7    |
| E2-02 (E4-02) | Motor Rated Slip                 | Hz               | 2.9     | 2.6    | 2.6    | 2.5    | 2.5    | 3      | 3      | 2.7    |
| E2-03 (E4-03) | Motor No-Load Current            | A                | 0.6     | 0.8    | 0.8    | 1.4    | 1.4    | 1.5    | 1.5    | 1.9    |
| E2-05 (E4-05) | Motor Line-to-Line Resistance    | Ω                | 38.198  | 22.459 | 22.459 | 10.1   | 10.1   | 6.495  | 6.495  | 4.360  |
| E2-06 (E4-06) | Motor Leakage Inductance         | %                | 18.2    | 14.3   | 14.3   | 18.3   | 18.3   | 18.7   | 18.7   | 19     |
| E2-10 (E4-10) | Motor Iron Loss                  | W                | 14      | 26     | 26     | 53     | 53     | 77     | 77     | 105    |
| E5-01         | PM Motor Code Selection          | -                | 1232    | 1232   | 1233   | 1233   | 1235   | 1235   | 1236   | 1236   |
| L2-02         | Power Loss Ride Through Time     | s                | 0.1     | 0.1    | 0.2    | 0.2    | 0.3    | 0.3    | 0.5    | 0.5    |
| L2-03         | Minimum Baseblock Time           | s                | 0.2     | 0.3    | 0.3    | 0.4    | 0.4    | 0.5    | 0.5    | 0.5    |
| L2-04         | Powerloss V/f Recovery Ramp Time | s                | 0.3     | 0.3    | 0.3    | 0.3    | 0.3    | 0.3    | 0.3    | 0.3    |
| L2-05         | Undervoltage Detection Lvl (Uv1) | -                | 380     | 380    | 380    | 380    | 380    | 380    | 380    | 380    |
| L3-24         | Motor Accel Time for Inertia Cal | s                | 0.178   | 0.142  | 0.142  | 0.166  | 0.166  | 0.145  | 0.145  | 0.145  |
| L8-02         | Overheat Alarm Level             | °C               | 100     | 100    | 105    | 105    | 112    | 112    | 100    | 100    |
| L8-09         | Output Ground Fault Detection    | -                | 1       | 1      | 1      | 1      | 1      | 1      | 1      | 1      |
| L8-38         | Carrier Frequency Reduction      | -                | 2       | 2      | 2      | 2      | 2      | 2      | 2      | 2      |
| n1-01         | Hunting Prevention Selection     | -                | 1       | 1      | 1      | 1      | 1      | 1      | 1      | 1      |

Parameter List

1

## 1.21 Defaults by Drive Model and Duty Rating ND/HD

| No. */        | Name                             | Unit | Default |       |       |       |       |       |       |       |
|---------------|----------------------------------|------|---------|-------|-------|-------|-------|-------|-------|-------|
|               |                                  |      | 4002    |       | 4004  |       | 4005  |       | 4007  |       |
| -             | Drive Model                      | -    | HD2     | ND2   | HD2   | ND2   | HD2   | ND2   | HD2   | ND2   |
| C6-01         | Normal / Heavy Duty Selection    | -    | 0       | 1     | 0     | 1     | 0     | 1     | 0     | 1     |
| o2-04         | Drive Model (KVA) Selection      | Hex. | 92      |       | 93    |       | 94    |       | 95    |       |
| E2-11 (E4-11) | Motor Rated Power (kW)           | kW   | 0.4     | 0.75  | 1.1   | 1.5   | 1.5   | 2.2   | 2.2   | 3.0   |
| n1-03         | Hunting Prevention Time Constant | ms   | 10      | 10    | 10    | 10    | 10    | 10    | 10    | 10    |
| n5-02         | Motor Inertia Acceleration Time  | s    | 0.178   | 0.142 | 0.142 | 0.166 | 0.166 | 0.145 | 0.145 | 0.145 |

\*1 Parameters within parentheses are for motor 2.

| No. */        | Name                             | Unit             | Default |        |        |        |       |        |        |        |
|---------------|----------------------------------|------------------|---------|--------|--------|--------|-------|--------|--------|--------|
|               |                                  |                  | 4009    |        | 4012   |        | 4018  |        | 4023   |        |
| -             | Drive Model                      | -                | HD2     | ND2    | HD2    | ND2    | HD2   | ND2    | HD2    | ND2    |
| C6-01         | Normal / Heavy Duty Selection    | -                | 0       | 1      | 0      | 1      | 0     | 1      | 0      | 1      |
| o2-04         | Drive Model (KVA) Selection      | Hex.             | 96      |        | 97     |        | 99    |        | 9A     |        |
| E2-11 (E4-11) | Motor Rated Power (kW)           | kW               | 3.0     | 4.0    | 4.0    | 5.5    | 5.5   | 7.5    | 7.5    | 11     |
| b3-04         | V/f Gain during Speed Search     | %                | 100     | 100    | 100    | 100    | 100   | 100    | 100    | 100    |
| b3-06         | Speed Estimation Current Level 1 | -                | 0.5     | 0.5    | 0.5    | 0.5    | 0.5   | 0.5    | 0.5    | 0.5    |
| b3-08         | Speed Estimation ACR P Gain      | -                | 0.5     | 0.5    | 0.5    | 0.5    | 0.5   | 0.5    | 0.5    | 0.5    |
| b3-26         | Direction Determination Level    | -                | 1000    | 1000   | 1000   | 1000   | 1000  | 1000   | 1000   | 1000   |
| b8-03         | Energy Saving Filter Time        | s                | 0.50    | 0.50   | 0.50   | 0.50   | 0.50  | 0.50   | 0.50   | 0.50   |
| b8-04         | Energy Saving Coefficient Value  | -                | 265.7   | 245.8  | 245.8  | 189.5  | 189.5 | 145.38 | 145.38 | 140.88 |
| C5-17 (C5-37) | Motor Inertia                    | kgm <sup>2</sup> | 0.0158  | 0.0158 | 0.0158 | 0.0255 | 0.026 | 0.037  | 0.037  | 0.053  |
| C6-02         | Carrier Frequency Selection      | -                | 1       | 7      | 1      | 7      | 1     | 7      | 1      | 7      |
| E2-01 (E4-01) | Motor Rated Current (FLA)        | A                | 5.7     | 7      | 7      | 9.8    | 9.8   | 13.3   | 13.3   | 19.9   |
| E2-02 (E4-02) | Motor Rated Slip                 | Hz               | 2.7     | 2.7    | 2.7    | 1.5    | 1.5   | 1.3    | 1.3    | 1.7    |
| E2-03 (E4-03) | Motor No-Load Current            | A                | 1.9     | 2.3    | 2.3    | 2.6    | 2.6   | 4      | 4      | 5.6    |
| E2-05 (E4-05) | Motor Line-to-Line Resistance    | Ω                | 4.360   | 3.333  | 3.333  | 1.595  | 1.595 | 1.152  | 1.152  | 0.922  |
| E2-06 (E4-06) | Motor Leakage Inductance         | %                | 19      | 19.3   | 19.3   | 18.2   | 18.2  | 15.5   | 15.5   | 19.6   |
| E2-10 (E4-10) | Motor Iron Loss                  | W                | 105     | 130    | 130    | 193    | 193   | 263    | 263    | 385    |

## 1.21 Defaults by Drive Model and Duty Rating ND/HD

| No. */        | Name                             | Unit | Default |       |       |       |       |       |       |       |
|---------------|----------------------------------|------|---------|-------|-------|-------|-------|-------|-------|-------|
|               |                                  |      | 4009    |       | 4012  |       | 4018  |       | 4023  |       |
| -             | Drive Model                      | -    | HD2     | ND2   | HD2   | ND2   | HD2   | ND2   | HD2   | ND2   |
| C6-01         | Normal / Heavy Duty Selection    | -    | 0       | 1     | 0     | 1     | 0     | 1     | 0     | 1     |
| o2-04         | Drive Model (KVA) Selection      | Hex. | 96      |       | 97    |       | 99    |       | 9A    |       |
| E2-11 (E4-11) | Motor Rated Power (kW)           | kW   | 3.0     | 4.0   | 4.0   | 5.5   | 5.5   | 7.5   | 7.5   | 11    |
| E5-01         | PM Motor Code Selection          | -    | FFFF    | FFFF  | 1238  | 1238  | 123A  | 123A  | 123B  | 123B  |
| L2-02         | Power Loss Ride Through Time     | s    | 0.5     | 0.5   | 0.5   | 0.5   | 0.8   | 0.8   | 1     | 1     |
| L2-03         | Minimum Baseblock Time           | s    | 0.5     | 0.6   | 0.6   | 0.7   | 0.7   | 0.8   | 0.8   | 0.9   |
| L2-04         | Powerloss V/f Recovery Ramp Time | s    | 0.3     | 0.3   | 0.3   | 0.3   | 0.3   | 0.3   | 0.3   | 0.3   |
| L2-05         | Undervoltage Detection Lvl (Uv1) | -    | 380     | 380   | 380   | 380   | 380   | 380   | 380   | 380   |
| L3-24         | Motor Accel Time for Inertia Cal | s    | 0.145   | 0.154 | 0.154 | 0.168 | 0.168 | 0.175 | 0.175 | 0.265 |
| L8-02         | Overheat Alarm Level             | °C   | 100     | 100   | 100   | 100   | 105   | 105   | 105   | 105   |
| L8-09         | Output Ground Fault Detection    | -    | 1       | 1     | 1     | 1     | 1     | 1     | 1     | 1     |
| L8-38         | Carrier Frequency Reduction      | -    | 2       | 2     | 2     | 2     | 2     | 2     | 2     | 2     |
| n1-01         | Hunting Prevention Selection     | -    | 1       | 1     | 1     | 1     | 1     | 1     | 1     | 1     |
| n1-03         | Hunting Prevention Time Constant | ms   | 10      | 10    | 10    | 10    | 10    | 10    | 10    | 10    |
| n5-02         | Motor Inertia Acceleration Time  | s    | 0.145   | 0.154 | 0.154 | 0.168 | 0.168 | 0.175 | 0.175 | 0.265 |

\*1 Parameters within parentheses are for motor 2.

| No.           | Name                             | Unit | Default |     |      |      |      |     |      |     |
|---------------|----------------------------------|------|---------|-----|------|------|------|-----|------|-----|
|               |                                  |      | 4031    |     | 4038 |      | 4044 |     | 4060 |     |
| -             | Drive Model                      | -    | HD2     | ND2 | HD2  | ND2  | HD2  | ND2 | HD2  | ND2 |
| C6-01         | Normal / Heavy Duty Selection    | -    | 0       | 1   | 0    | 1    | 0    | 1   | 0    | 1   |
| o2-04         | Drive Model (KVA) Selection      | Hex. | 9C      |     | 9D   |      | 9E   |     | 9F   |     |
| E2-11 (E4-11) | Motor Rated Power (kW)           | kW   | 11      | 15  | 15   | 18.5 | 18.5 | 22  | 22   | 30  |
| b3-04         | V/f Gain during Speed Search     | %    | 100     | 100 | 100  | 100  | 100  | 100 | 100  | 100 |
| b3-06         | Speed Estimation Current Level 1 | -    | 0.5     | 0.5 | 0.5  | 0.5  | 0.5  | 0.5 | 0.5  | 0.5 |
| b3-08         | Speed Estimation ACR P Gain      | -    | 0.5     | 0.5 | 0.5  | 0.5  | 0.5  | 0.5 | 0.5  | 0.5 |

Parameter List

1

## 1.21 Defaults by Drive Model and Duty Rating ND/HD

| No.           | Name                             | Unit             | Default |        |        |        |        |        |        |       |
|---------------|----------------------------------|------------------|---------|--------|--------|--------|--------|--------|--------|-------|
|               |                                  |                  | 4031    |        | 4038   |        | 4044   |        | 4060   |       |
| -             | Drive Model                      | -                | HD2     | ND2    | HD2    | ND2    | HD2    | ND2    | HD2    | ND2   |
| C6-01         | Normal / Heavy Duty Selection    | -                | 0       | 1      | 0      | 1      | 0      | 1      | 0      | 1     |
| o2-04         | Drive Model (KVA) Selection      | Hex.             | 9C      |        | 9D     |        | 9E     |        | 9F     |       |
| E2-11 (E4-11) | Motor Rated Power (kW)           | kW               | 11      | 15     | 15     | 18.5   | 18.5   | 22     | 22     | 30    |
| b3-26         | Direction Determination Level    | -                | 1000    | 1000   | 1000   | 1000   | 1000   | 1000   | 1000   | 1000  |
| b8-03         | Energy Saving Filter Time        | s                | 0.50    | 0.50   | 0.50   | 0.50   | 0.50   | 0.50   | 0.50   | 0.50  |
| b8-04         | Energy Saving Coefficient Value  | -                | 140.88  | 126.26 | 126.26 | 115.74 | 115.74 | 103.58 | 103.58 | 92.54 |
| C5-17 (C5-37) | Motor Inertia                    | kgm <sup>2</sup> | 0.053   | 0.076  | 0.076  | 0.138  | 0.138  | 0.165  | 0.165  | 0.220 |
| C6-02         | Carrier Frequency Selection      | -                | 1       | 7      | 1      | 7      | 1      | 7      | 1      | 7     |
| E2-01 (E4-01) | Motor Rated Current (FLA)        | A                | 19.9    | 26.5   | 26.5   | 32.9   | 32.9   | 38.6   | 38.6   | 52.3  |
| E2-02 (E4-02) | Motor Rated Slip                 | Hz               | 1.7     | 1.6    | 1.6    | 1.67   | 1.67   | 1.7    | 1.7    | 1.8   |
| E2-03 (E4-03) | Motor No-Load Current            | A                | 5.6     | 7.6    | 7.6    | 7.8    | 7.8    | 9.2    | 9.2    | 10.9  |
| E2-05 (E4-05) | Motor Line-to-Line Resistance    | Ω                | 0.922   | 0.55   | 0.55   | 0.403  | 0.403  | 0.316  | 0.316  | 0.269 |
| E2-06 (E4-06) | Motor Leakage Inductance         | %                | 19.6    | 17.2   | 17.2   | 20.1   | 20.1   | 23.5   | 23.5   | 20.7  |
| E2-10 (E4-10) | Motor Iron Loss                  | W                | 385     | 440    | 440    | 508    | 508    | 586    | 586    | 750   |
| E5-01         | PM Motor Code Selection          | -                | 123D    | 123D   | 123E   | 123E   | 123F   | 123F   | 1240   | 1240  |
| L2-02         | Power Loss Ride Through Time     | s                | 2       | 2      | 2      | 2      | 2      | 2      | 2      | 2     |
| L2-03         | Minimum Baseblock Time           | s                | 0.9     | 1      | 1      | 1      | 1      | 1      | 1      | 1.1   |
| L2-04         | Powerloss V/f Recovery Ramp Time | s                | 0.3     | 0.6    | 0.6    | 0.6    | 0.6    | 0.6    | 0.6    | 0.6   |
| L2-05         | Undervoltage Detection Lvl (Uv1) | -                | 380     | 380    | 380    | 380    | 380    | 380    | 380    | 380   |
| L3-24         | Motor Accel Time for Inertia Cal | s                | 0.265   | 0.244  | 0.244  | 0.317  | 0.317  | 0.355  | 0.355  | 0.323 |
| L8-02         | Overheat Alarm Level             | °C               | 115     | 115    | 120    | 120    | 120    | 120    | 130    | 137   |
| L8-09         | Output Ground Fault Detection    | -                | 1       | 1      | 1      | 1      | 1      | 1      | 1      | 1     |
| L8-38         | Carrier Frequency Reduction      | -                | 2       | 2      | 2      | 2      | 2      | 2      | 2      | 2     |
| n1-01         | Hunting Prevention Selection     | -                | 2       | 2      | 2      | 2      | 2      | 2      | 2      | 2     |

## 1.21 Defaults by Drive Model and Duty Rating ND/HD

| No.           | Name                             | Unit | Default |       |       |       |       |       |       |       |
|---------------|----------------------------------|------|---------|-------|-------|-------|-------|-------|-------|-------|
|               |                                  |      | 4031    |       | 4038  |       | 4044  |       | 4060  |       |
| -             | Drive Model                      | -    | HD2     | ND2   | HD2   | ND2   | HD2   | ND2   | HD2   | ND2   |
| C6-01         | Normal / Heavy Duty Selection    | -    | 0       | 1     | 0     | 1     | 0     | 1     | 0     | 1     |
| o2-04         | Drive Model (KVA) Selection      | Hex. | 9C      |       | 9D    |       | 9E    |       | 9F    |       |
| E2-11 (E4-11) | Motor Rated Power (kW)           | kW   | 11      | 15    | 15    | 18.5  | 18.5  | 22    | 22    | 30    |
| n1-03         | Hunting Prevention Time Constant | ms   | 10      | 10    | 10    | 10    | 10    | 10    | 10    | 10    |
| n5-02         | Motor Inertia Acceleration Time  | s    | 0.265   | 0.244 | 0.244 | 0.317 | 0.317 | 0.355 | 0.355 | 0.323 |

\*1 Parameters within parentheses are for motor 2.

| No.           | Name                             | Unit             | Default |       |       |       |       |       |       |       |
|---------------|----------------------------------|------------------|---------|-------|-------|-------|-------|-------|-------|-------|
|               |                                  |                  | 4075    |       | 4089  |       | 4103  |       | 4140  |       |
| -             | Drive Model                      | -                | HD2     | ND2   | HD2   | ND2   | HD2   | ND2   | HD2   | ND2   |
| C6-01         | Normal / Heavy Duty Selection    | -                | 0       | 1     | 0     | 1     | 0     | 1     | 0     | 1     |
| o2-04         | Drive Model (KVA) Selection      | Hex.             | A1      |       | A2    |       | A3    |       | A4    |       |
| E2-11 (E4-11) | Motor Rated Power (kW)           | kW               | 30      | 37    | 37    | 45    | 45    | 55    | 55    | 75    |
| b3-04         | V/f Gain during Speed Search     | %                | 100     | 100   | 100   | 100   | 100   | 80    | 80    | 60    |
| b3-06         | Speed Estimation Current Level 1 | -                | 0.5     | 0.5   | 0.5   | 0.5   | 0.5   | 0.5   | 0.5   | 0.7   |
| b3-08         | Speed Estimation ACR P Gain      | -                | 0.5     | 0.5   | 0.5   | 0.5   | 0.5   | 0.5   | 0.5   | 0.8   |
| b3-26         | Direction Determination Level    | -                | 1000    | 1000  | 1000  | 1000  | 1000  | 1000  | 1000  | 1000  |
| b8-03         | Energy Saving Filter Time        | s                | 0.50    | 0.50  | 0.50  | 0.50  | 0.50  | 2.00  | 2.00  | 2.00  |
| b8-04         | Energy Saving Coefficient Value  | -                | 92.54   | 76.32 | 76.32 | 71.56 | 71.56 | 67.2  | 67.2  | 46.2  |
| C5-17 (C5-37) | Motor Inertia                    | kgm <sup>2</sup> | 0.220   | 0.273 | 0.273 | 0.333 | 0.333 | 0.490 | 0.49  | 0.90  |
| C6-02         | Carrier Frequency Selection      | -                | 1       | 7     | 1     | 7     | 1     | 7     | 1     | 7     |
| E2-01 (E4-01) | Motor Rated Current (FLA)        | A                | 52.3    | 65.6  | 65.6  | 79.7  | 79.7  | 95    | 95    | 130   |
| E2-02 (E4-02) | Motor Rated Slip                 | Hz               | 1.8     | 1.33  | 1.33  | 1.6   | 1.6   | 1.46  | 1.46  | 1.39  |
| E2-03 (E4-03) | Motor No-Load Current            | A                | 10.9    | 19.1  | 19.1  | 22    | 22    | 24    | 24    | 36    |
| E2-05 (E4-05) | Motor Line-to-Line Resistance    | Ω                | 0.269   | 0.155 | 0.155 | 0.122 | 0.122 | 0.088 | 0.088 | 0.092 |
| E2-06 (E4-06) | Motor Leakage Inductance         | %                | 20.7    | 18.8  | 18.8  | 19.9  | 19.9  | 20    | 20    | 20    |
| E2-10 (E4-10) | Motor Iron Loss                  | W                | 750     | 925   | 925   | 1125  | 1125  | 1260  | 1260  | 1600  |

Parameter List

1

## 1.21 Defaults by Drive Model and Duty Rating ND/HD

| No.           | Name                             | Unit | Default |      |      |       |       |       |       |       |
|---------------|----------------------------------|------|---------|------|------|-------|-------|-------|-------|-------|
|               |                                  |      | 4075    |      | 4089 |       | 4103  |       | 4140  |       |
| -             | Drive Model                      | -    | HD2     | ND2  | HD2  | ND2   | HD2   | ND2   | HD2   | ND2   |
| C6-01         | Normal / Heavy Duty Selection    | -    | 0       | 1    | 0    | 1     | 0     | 1     | 0     | 1     |
| o2-04         | Drive Model (KVA) Selection      | Hex. | A1      |      | A2   |       | A3    |       | A4    |       |
| E2-11 (E4-11) | Motor Rated Power (kW)           | kW   | 30      | 37   | 37   | 45    | 45    | 55    | 55    | 75    |
| E5-01         | PM Motor Code Selection          | -    | 1242    | 1242 | 1243 | 1243  | 1244  | 1244  | 1245  | 1245  |
| L2-02         | Power Loss Ride Through Time     | s    | 2       | 2    | 2    | 2     | 2     | 2     | 2     | 2     |
| L2-03         | Minimum Baseblock Time           | s    | 1.1     | 1.1  | 1.1  | 1.2   | 1.2   | 1.2   | 1.2   | 1.3   |
| L2-04         | Powerloss V/f Recovery Ramp Time | s    | 0.6     | 0.6  | 0.6  | 0.6   | 0.6   | 1     | 1     | 1     |
| L2-05         | Undervoltage Detection Lvl (Uv1) | -    | 380     | 380  | 380  | 380   | 380   | 380   | 380   | 380   |
| L3-24         | Motor Accel Time for Inertia Cal | s    | 0.323   | 0.32 | 0.32 | 0.387 | 0.387 | 0.317 | 0.317 | 0.533 |
| L8-02         | Overheat Alarm Level             | °C   | 120     | 120  | 115  | 115   | 126   | 120   | 120   | 120   |
| L8-09         | Output Ground Fault Detection    | -    | 1       | 1    | 1    | 1     | 1     | 1     | 1     | 1     |
| L8-38         | Carrier Frequency Reduction      | -    | 2       | 2    | 2    | 2     | 2     | 2     | 2     | 2     |
| n1-01         | Hunting Prevention Selection     | -    | 2       | 2    | 2    | 2     | 2     | 2     | 2     | 2     |
| n1-03         | Hunting Prevention Time Constant | ms   | 10      | 10   | 10   | 10    | 10    | 10    | 30    | 30    |
| n5-02         | Motor Inertia Acceleration Time  | s    | 0.323   | 0.32 | 0.32 | 0.387 | 0.387 | 0.317 | 0.317 | 0.533 |

\*1 Parameters within parentheses are for motor 2.

| No.           | Name                             | Unit | Default |     |      |     |      |     |      |     |
|---------------|----------------------------------|------|---------|-----|------|-----|------|-----|------|-----|
|               |                                  |      | 4168    |     | 4208 |     | 4250 |     | 4302 |     |
| -             | Drive Model                      | -    | HD2     | ND2 | HD2  | ND2 | HD2  | ND2 | HD2  | ND2 |
| C6-01         | Normal / Heavy Duty Selection    | -    | 0       | 1   | 0    | 1   | 0    | 1   | 0    | 1   |
| o2-04         | Drive Model (KVA) Selection      | Hex. | A5      |     | A6   |     | A7   |     | A8   |     |
| E2-11 (E4-11) | Motor Rated Power (kW)           | kW   | 75      | 90  | 90   | 110 | 110  | 150 | 150  | 185 |
| b3-04         | V/f Gain during Speed Search     | %    | 60      | 60  | 60   | 60  | 60   | 60  | 60   | 60  |
| b3-06         | Speed Estimation Current Level 1 | -    | 0.7     | 0.7 | 0.7  | 0.7 | 0.7  | 0.7 | 0.7  | 0.7 |
| b3-08         | Speed Estimation ACR P Gain      | -    | 0.8     | 0.8 | 0.8  | 0.8 | 0.8  | 0.8 | 0.8  | 0.8 |



1.21 Defaults by Drive Model and Duty Rating ND/HD

| No.           | Name                             | Unit             | Default |       |       |       |       |       |       |       |
|---------------|----------------------------------|------------------|---------|-------|-------|-------|-------|-------|-------|-------|
|               |                                  |                  | 4168    |       | 4208  |       | 4250  |       | 4302  |       |
| -             | Drive Model                      | -                | HD2     | ND2   | HD2   | ND2   | HD2   | ND2   | HD2   | ND2   |
| C6-01         | Normal / Heavy Duty Selection    | -                | 0       | 1     | 0     | 1     | 0     | 1     | 0     | 1     |
| o2-04         | Drive Model (KVA) Selection      | Hex.             | A5      |       | A6    |       | A7    |       | A8    |       |
| E2-11 (E4-11) | Motor Rated Power (kW)           | kW               | 75      | 90    | 90    | 110   | 110   | 150   | 150   | 185   |
| b3-26         | Direction Determination Level    | -                | 1000    | 1000  | 1000  | 1000  | 1000  | 1000  | 1000  | 1000  |
| b8-03         | Energy Saving Filter Time        | s                | 2.00    | 2.00  | 2.00  | 2.00  | 2.00  | 2.00  | 2.00  | 2.00  |
| b8-04         | Energy Saving Coefficient Value  | -                | 46.2    | 38.91 | 38.91 | 36.23 | 36.23 | 32.79 | 32.79 | 30.13 |
| C5-17 (C5-37) | Motor Inertia                    | kgm <sup>2</sup> | 0.90    | 1.10  | 1.10  | 1.90  | 1.90  | 2.10  | 2.10  | 3.30  |
| C6-02         | Carrier Frequency Selection      | -                | 1       | 7     | 1     | 7     | 1     | 7     | 1     | 7     |
| E2-01 (E4-01) | Motor Rated Current (FLA)        | A                | 130     | 156   | 156   | 190   | 190   | 223   | 223   | 270   |
| E2-02 (E4-02) | Motor Rated Slip                 | Hz               | 1.39    | 1.4   | 1.4   | 1.4   | 1.4   | 1.38  | 1.38  | 1.35  |
| E2-03 (E4-03) | Motor No-Load Current            | A                | 36      | 40    | 40    | 49    | 49    | 58    | 58    | 70    |
| E2-05 (E4-05) | Motor Line-to-Line Resistance    | Ω                | 0.092   | 0.056 | 0.056 | 0.046 | 0.046 | 0.035 | 0.035 | 0.029 |
| E2-06 (E4-06) | Motor Leakage Inductance         | %                | 20      | 20    | 20    | 20    | 20    | 20    | 20    | 20    |
| E2-10 (E4-10) | Motor Iron Loss                  | W                | 1600    | 1760  | 1760  | 2150  | 2150  | 2350  | 2350  | 2850  |
| E5-01         | PM Motor Code Selection          | -                | 1246    | 1246  | 1247  | 1247  | 1248  | 1248  | 1249  | 1249  |
| L2-02         | Power Loss Ride Through Time     | s                | 2       | 2     | 2     | 2     | 2     | 2     | 2     | 2     |
| L2-03         | Minimum Baseblock Time           | s                | 1.3     | 1.5   | 1.5   | 1.7   | 1.7   | 1.7   | 1.7   | 1.8   |
| L2-04         | Powerloss V/f Recovery Ramp Time | s                | 1       | 1     | 1     | 1     | 1     | 1     | 1     | 1     |
| L2-05         | Undervoltage Detection Lvl (Uv1) | -                | 380     | 380   | 380   | 380   | 380   | 380   | 380   | 380   |
| L3-24         | Motor Accel Time for Inertia Cal | s                | 0.533   | 0.592 | 0.592 | 0.646 | 0.646 | 0.673 | 0.673 | 0.777 |
| L8-02         | Overheat Alarm Level             | °C               | 110     | 110   | 105   | 105   | 120   | 120   | 120   | 120   |
| L8-09         | Output Ground Fault Detection    | -                | 1       | 1     | 1     | 1     | 1     | 1     | 1     | 1     |
| L8-38         | Carrier Frequency Reduction      | -                | 2       | 2     | 2     | 2     | 2     | 2     | 2     | 2     |
| n1-01         | Hunting Prevention Selection     | -                | 2       | 2     | 2     | 2     | 2     | 2     | 2     | 2     |

Parameter List

## 1.21 Defaults by Drive Model and Duty Rating ND/HD

| No.           | Name                             | Unit | Default |       |       |       |       |       |       |       |
|---------------|----------------------------------|------|---------|-------|-------|-------|-------|-------|-------|-------|
|               |                                  |      | 4168    |       | 4208  |       | 4250  |       | 4302  |       |
| -             | Drive Model                      | -    | HD2     | ND2   | HD2   | ND2   | HD2   | ND2   | HD2   | ND2   |
| C6-01         | Normal / Heavy Duty Selection    | -    | 0       | 1     | 0     | 1     | 0     | 1     | 0     | 1     |
| o2-04         | Drive Model (KVA) Selection      | Hex. | A5      |       | A6    |       | A7    |       | A8    |       |
| E2-11 (E4-11) | Motor Rated Power (kW)           | kW   | 75      | 90    | 90    | 110   | 110   | 150   | 150   | 185   |
| n1-03         | Hunting Prevention Time Constant | ms   | 30      | 30    | 30    | 30    | 30    | 30    | 30    | 30    |
| n5-02         | Motor Inertia Acceleration Time  | s    | 0.533   | 0.592 | 0.592 | 0.646 | 0.646 | 0.673 | 0.673 | 0.777 |

\*1 Parameters within parentheses are for motor 2.

| No.           | Name                             | Unit             | Default |       |       |       |       |       |       |       |
|---------------|----------------------------------|------------------|---------|-------|-------|-------|-------|-------|-------|-------|
|               |                                  |                  | 4371    |       | 4414  |       | 4477  |       | 4568  |       |
| -             | Drive Model                      | -                | HD2     | ND2   | HD2   | ND2   | HD2   | ND2   | HD2   | ND2   |
| C6-01         | Normal / Heavy Duty Selection    | -                | 0       | 1     | 0     | 1     | 0     | 1     | 0     | 1     |
| o2-04         | Drive Model (KVA) Selection      | Hex.             | A9      |       | AA    |       | AC    |       | AD    |       |
| E2-11 (E4-11) | Motor Rated Power (kW)           | kW               | 185     | 220   | 220   | 260   | 260   | 300   | 300   | 335   |
| b3-04         | V/f Gain during Speed Search     | %                | 60      | 60    | 60    | 60    | 60    | 60    | 60    | 60    |
| b3-06         | Speed Estimation Current Level 1 | -                | 0.7     | 0.7   | 0.7   | 0.7   | 0.7   | 0.7   | 0.7   | 0.7   |
| b3-08         | Speed Estimation ACR P Gain      | -                | 0.8     | 0.8   | 0.8   | 0.8   | 0.8   | 0.8   | 0.8   | 0.8   |
| b3-26         | Direction Determination Level    | -                | 1000    | 1000  | 1000  | 1000  | 1000  | 1000  | 1000  | 1000  |
| b8-03         | Energy Saving Filter Time        | s                | 2.00    | 2.00  | 2.00  | 2.00  | 2.00  | 2.00  | 2.00  | 2.00  |
| b8-04         | Energy Saving Coefficient Value  | -                | 30.13   | 30.57 | 30.57 | 27.13 | 27.13 | 21.76 | 21.76 | 21.76 |
| C5-17 (C5-37) | Motor Inertia                    | kgm <sup>2</sup> | 3.30    | 3.60  | 3.60  | 4.10  | 4.10  | 6.50  | 6.50  | 11.00 |
| C6-02         | Carrier Frequency Selection      | -                | 1       | 7     | 1     | 7     | 1     | 7     | 1     | 7     |
| E2-01 (E4-01) | Motor Rated Current (FLA)        | A                | 270     | 310   | 310   | 370   | 370   | 500   | 500   | 500   |
| E2-02 (E4-02) | Motor Rated Slip                 | Hz               | 1.35    | 1.3   | 1.3   | 1.3   | 1.3   | 1.25  | 1.25  | 1.25  |
| E2-03 (E4-03) | Motor No-Load Current            | A                | 70      | 81    | 81    | 96    | 96    | 130   | 130   | 130   |
| E2-05 (E4-05) | Motor Line-to-Line Resistance    | Ω                | 0.029   | 0.025 | 0.025 | 0.02  | 0.02  | 0.014 | 0.014 | 0.014 |
| E2-06 (E4-06) | Motor Leakage Inductance         | %                | 20      | 20    | 20    | 20    | 20    | 20    | 20    | 20    |
| E2-10 (E4-10) | Motor Iron Loss                  | W                | 2850    | 3200  | 3200  | 3700  | 3700  | 4700  | 4700  | 4700  |

## 1.21 Defaults by Drive Model and Duty Rating ND/HD

| No.           | Name                             | Unit | Default |       |       |      |      |       |       |       |
|---------------|----------------------------------|------|---------|-------|-------|------|------|-------|-------|-------|
|               |                                  |      | 4371    |       | 4414  |      | 4477 |       | 4568  |       |
| -             | Drive Model                      | -    | HD2     | ND2   | HD2   | ND2  | HD2  | ND2   | HD2   | ND2   |
| C6-01         | Normal / Heavy Duty Selection    | -    | 0       | 1     | 0     | 1    | 0    | 1     | 0     | 1     |
| o2-04         | Drive Model (KVA) Selection      | Hex. | A9      |       | AA    |      | AC   |       | AD    |       |
| E2-11 (E4-11) | Motor Rated Power (kW)           | kW   | 185     | 220   | 220   | 260  | 260  | 300   | 300   | 335   |
| E5-01         | PM Motor Code Selection          | -    | 124A    | 124A  | 124A  | 124A | 124A | 124A  | 124A  | 124A  |
| L2-02         | Power Loss Ride Through Time     | s    | 2       | 2     | 2     | 2    | 2    | 2     | 2     | 2     |
| L2-03         | Minimum Baseblock Time           | s    | 1.8     | 1.9   | 1.9   | 2    | 2    | 2.1   | 2.1   | 2.1   |
| L2-04         | Powerloss V/f Recovery Ramp Time | s    | 1       | 1     | 1.8   | 1.8  | 1.8  | 2     | 2     | 2     |
| L2-05         | Undervoltage Detection Lvl (Uv1) | -    | 380     | 380   | 380   | 380  | 380  | 380   | 380   | 380   |
| L3-24         | Motor Accel Time for Inertia Cal | s    | 0.777   | 0.864 | 0.864 | 0.91 | 0.91 | 1.392 | 1.392 | 1.392 |
| L8-02         | Overheat Alarm Level             | °C   | 125     | 125   | 125   | 125  | 110  | 110   | 125   | 115   |
| L8-09         | Output Ground Fault Detection    | -    | 1       | 1     | 1     | 1    | 1    | 1     | 1     | 1     |
| L8-38         | Carrier Frequency Reduction      | -    | 2       | 2     | 2     | 2    | 2    | 2     | 2     | 2     |
| n1-01         | Hunting Prevention Selection     | -    | 2       | 2     | 2     | 2    | 2    | 2     | 2     | 2     |
| n1-03         | Hunting Prevention Time Constant | ms   | 30      | 30    | 100   | 100  | 100  | 100   | 100   | 100   |
| n5-02         | Motor Inertia Acceleration Time  | s    | 0.777   | 0.864 | 0.864 | 0.91 | 0.91 | 1.392 | 1.392 | 1.392 |

\*1 Parameters within parentheses are for motor 2.

| No.           | Name                             | Unit | Default |      |      |      |
|---------------|----------------------------------|------|---------|------|------|------|
|               |                                  |      | 4605    |      | 4720 |      |
| -             | Drive Model                      | -    | HD2     | ND2  | HD2  | ND2  |
| C6-01         | Normal / Heavy Duty Selection    | -    | 0       | 1    | 0    | 1    |
| o2-04         | Drive Model (KVA) Selection      | Hex. | AE      |      | AF   |      |
| E2-11 (E4-11) | Motor Rated Power (kW)           | kW   | 335     | 370  | 370  | 450  |
| b3-04         | V/f Gain during Speed Search     | %    | 60      | 60   | 60   | 60   |
| b3-06         | Speed Estimation Current Level 1 | -    | 0.7     | 0.7  | 0.7  | 0.7  |
| b3-08         | Speed Estimation ACR P Gain      | -    | 0.8     | 0.8  | 0.8  | 0.8  |
| b3-26         | Direction Determination Level    | -    | 1000    | 1000 | 1000 | 1000 |
| b8-03         | Energy Saving Filter Time        | s    | 2.00    | 2.00 | 2.00 | 2.00 |

Parameter List

1

## 1.21 Defaults by Drive Model and Duty Rating ND/HD

| No.              | Name                             | Unit             | Default |       |       |       |
|------------------|----------------------------------|------------------|---------|-------|-------|-------|
|                  |                                  |                  | 4605    |       | 4720  |       |
| -                | Drive Model                      | -                |         |       |       |       |
| C6-01            | Normal / Heavy Duty Selection    | -                | HD2     | ND2   | HD2   | ND2   |
|                  |                                  |                  | 0       | 1     | 0     | 1     |
| o2-04            | Drive Model (KVA) Selection      | Hex.             | AE      |       | AF    |       |
| E2-11<br>(E4-11) | Motor Rated Power (kW)           | kW               | 335     | 370   | 370   | 450   |
| b8-04            | Energy Saving Coefficient Value  | -                | 21.76   | 23.84 | 21.76 | 23.84 |
| C5-17<br>(C5-37) | Motor Inertia                    | kgm <sup>2</sup> | 11.00   | 12.00 | 11.00 | 12.00 |
| C6-02            | Carrier Frequency Selection      | -                | 1       | 7     | 1     | 7     |
| E2-01<br>(E4-01) | Motor Rated Current (FLA)        | A                | 500     | 650   | 500   | 650   |
| E2-02<br>(E4-02) | Motor Rated Slip                 | Hz               | 1.25    | 1     | 1.25  | 1     |
| E2-03<br>(E4-03) | Motor No-Load Current            | A                | 130     | 130   | 130   | 130   |
| E2-05<br>(E4-05) | Motor Line-to-Line Resistance    | Ω                | 0.014   | 0.012 | 0.014 | 0.012 |
| E2-06<br>(E4-06) | Motor Leakage Inductance         | %                | 20      | 20    | 20    | 20    |
| E2-10<br>(E4-10) | Motor Iron Loss                  | W                | 4700    | 5560  | 4700  | 5560  |
| E5-01            | PM Motor Code Selection          | -                | FFFF    | FFFF  | FFFF  | FFFF  |
| L2-02            | Power Loss Ride Through Time     | s                | 2       | 2     | 2     | 2     |
| L2-03            | Minimum Baseblock Time           | s                | 2.1     | 2.3   | 2.1   | 2.3   |
| L2-04            | Powerloss V/f Recovery Ramp Time | s                | 2       | 2.2   | 2     | 2.2   |
| L2-05            | Undervoltage Detection Lvl (Uv1) | -                | 380     | 380   | 380   | 380   |
| L3-24            | Motor Accel Time for Inertia Cal | s                | 1.392   | 1.667 | 1.392 | 1.667 |
| L8-02            | Overheat Alarm Level             | °C               | 133     | 133   | 125   | 125   |
| L8-09            | Output Ground Fault Detection    | -                | 1       | 1     | 1     | 1     |
| L8-38            | Carrier Frequency Reduction      | -                | 2       | 2     | 2     | 2     |
| n1-01            | Hunting Prevention Selection     | -                | 2       | 2     | 2     | 2     |
| n1-03            | Hunting Prevention Time Constant | ms               | 100     | 100   | 100   | 100   |
| n5-02            | Motor Inertia Acceleration Time  | s                | 1.392   | 1.667 | 1.392 | 1.667 |

\*1 Parameters within parentheses are for motor 2.

## 1.22 Parameters Changed by PM Motor Code Selection

**Note:**

The motor codes listed in these tables are the only correct setting values.

### ◆ Yaskawa SMRA Series SPM Motors

**Table 1.4 SMRA series motor code setting for specification of 200 V at 1800 min<sup>-1</sup> (r/min)**

| No.   | Name                                       | Unit                 | Motor Code (setting value of E5-01) |        |        |        |        |
|-------|--|----------------------|-------------------------------------|--------|--------|--------|--------|
| E5-01 | PM Motor Code Selection                    | -                    | 0002                                | 0003   | 0005   | 0006   | 0008   |
|       | Voltage Class                              | V                    | 200                                 | 200    | 200    | 200    | 200    |
|       | Capacity                                   | kW                   | 0.4                                 | 0.75   | 1.5    | 2.2    | 3.7    |
|       | Motor Rotation Speed                       | min <sup>-1</sup>    | 1800                                | 1800   | 1800   | 1800   | 1800   |
| E5-02 | PM Motor Rated Power                       | kW                   | 0.4                                 | 0.75   | 1.5    | 2.2    | 3.7    |
| E5-03 | PM Motor Rated Current (FLA)               | A                    | 2.1                                 | 4.0    | 6.9    | 10.8   | 17.4   |
| E5-04 | PM Motor Pole Count                        | -                    | 8                                   | 8      | 8      | 8      | 8      |
| E5-05 | PM Motor Resistance (ohms/phase)           | Ω                    | 2.47                                | 1.02   | 0.679  | 0.291  | 0.169  |
| E5-06 | PM d-axis Inductance (mH/phase)            | mH                   | 12.7                                | 4.8    | 3.9    | 3.6    | 2.5    |
| E5-07 | PM q-axis Inductance (mH/phase)            | mH                   | 12.7                                | 4.8    | 3.9    | 3.6    | 2.5    |
| E5-09 | PM Back-EMF V <sub>peak</sub> (mV/(rad/s)) | mVs/rad              | 0                                   | 0      | 0      | 0      | 0      |
| E5-24 | PM Back-EMF L-L V <sub>rms</sub> (mV/rpm)  | mV/min <sup>-1</sup> | 62.0                                | 64.1   | 73.4   | 69.6   | 72.2   |
| E1-04 | Maximum Output Frequency                   | Hz                   | 120                                 | 120    | 120    | 120    | 120    |
| E1-05 | Maximum Output Voltage                     | V                    | 200.0                               | 200.0  | 200.0  | 200.0  | 200.0  |
| E1-06 | Base Frequency                             | Hz                   | 120                                 | 120    | 120    | 120    | 120    |
| E1-09 | Minimum Output Frequency                   | Hz                   | 6                                   | 6      | 6      | 6      | 6      |
| C5-17 | Motor Inertia                              | kgm <sup>2</sup>     | 0.0007                              | 0.0014 | 0.0021 | 0.0032 | 0.0046 |
| L3-24 | Motor Accel Time @ Rated Torque            | s                    | 0.064                               | 0.066  | 0.049  | 0.051  | 0.044  |
| n5-02 | Motor Inertia Acceleration Time            | s                    | 0.064                               | 0.066  | 0.049  | 0.051  | 0.044  |
| n8-49 | Heavy Load Id Current                      | %                    | 0                                   | 0      | 0      | 0      | 0      |

**Table 1.5 SMRA Series Motor Code Setting for Specification of 200 V at 3600 min<sup>-1</sup> (r/min)**

| No.   | Name                             | Unit              | Motor Code (setting value of E5-01) |      |      |       |
|-------|----------------------------------|-------------------|-------------------------------------|------|------|-------|
| E5-01 | PM Motor Code Selection          | -                 | 0103                                | 0105 | 0106 | 0108  |
|       | Voltage Class                    | V                 | 200                                 | 200  | 200  | 200   |
|       | Capacity                         | kW                | 0.75                                | 1.5  | 2.2  | 3.7   |
|       | Motor Rotation Speed             | min <sup>-1</sup> | 3600                                | 3600 | 3600 | 3600  |
| E5-02 | PM Motor Rated Power             | kW                | 0.75                                | 1.5  | 2.2  | 3.7   |
| E5-03 | PM Motor Rated Current (FLA)     | A                 | 4.1                                 | 8.0  | 10.5 | 16.5  |
| E5-04 | PM Motor Pole Count              | -                 | 8                                   | 8    | 8    | 8     |
| E5-05 | PM Motor Resistance (ohms/phase) | Ω                 | 0.538                               | 0.20 | 0.15 | 0.097 |
| E5-06 | PM d-axis Inductance (mH/phase)  | mH                | 3.2                                 | 1.3  | 1.1  | 1.1   |
| E5-07 | PM q-axis Inductance (mH/phase)  | mH                | 3.2                                 | 1.3  | 1.1  | 1.1   |

## 1.22 Parameters Changed by PM Motor Code Selection

| No.   | Name                            | Unit                 | Motor Code (setting value of E5-01) |        |        |        |
|-------|---------------------------------|----------------------|-------------------------------------|--------|--------|--------|
| E5-09 | PM Back-EMF Vpeak (mV/(rad/s))  | mVs/rad              | 0                                   | 0      | 0      | 0      |
| E5-24 | PM Back-EMF L-L Vrms (mV/rpm)   | mV/min <sup>-1</sup> | 32.4                                | 32.7   | 36.7   | 39.7   |
| E1-04 | Maximum Output Frequency        | Hz                   | 240                                 | 240    | 240    | 240    |
| E1-05 | Maximum Output Voltage          | V                    | 200.0                               | 200.0  | 200.0  | 200.0  |
| E1-06 | Base Frequency                  | Hz                   | 240                                 | 240    | 240    | 240    |
| E1-09 | Minimum Output Frequency        | Hz                   | 12                                  | 12     | 12     | 12     |
| C5-17 | Motor Inertia                   | kgm <sup>2</sup>     | 0.0007                              | 0.0014 | 0.0021 | 0.0032 |
| L3-24 | Motor Accel Time @ Rated Torque | s                    | 0.137                               | 0.132  | 0.132  | 0.122  |
| n5-02 | Motor Inertia Acceleration Time | s                    | 0.137                               | 0.132  | 0.132  | 0.122  |
| n8-49 | Heavy Load Id Current           | %                    | 0                                   | 0      | 0      | 0      |

### ◆ Yaskawa SSR1 Series IPM Motors (Derated Torque)

Table 1.6 SSR1 Series Motor Code Setting for Specification of 200 V at 1750 min<sup>-1</sup> (r/min)

| No.         | Name                             | Unit                 | Motor Code (setting value of E5-01) |        |        |        |        |       |       |       |
|-------------|----------------------------------|----------------------|-------------------------------------|--------|--------|--------|--------|-------|-------|-------|
| E5-01       | PM Motor Code Selection          | -                    | 1202                                | 1203   | 1205   | 1206   | 1208   | 120A  | 120B  | 120D  |
|             | Voltage Class                    | V                    | 200                                 | 200    | 200    | 200    | 200    | 200   | 200   | 200   |
|             | Capacity                         | kW                   | 0.4                                 | 0.75   | 1.5    | 2.2    | 3.7    | 5.5   | 7.5   | 11    |
|             | Motor Rotation Speed             | min <sup>-1</sup>    | 1750                                | 1750   | 1750   | 1750   | 1750   | 1750  | 1750  | 1750  |
| E5-02       | PM Motor Rated Power             | kW                   | 0.4                                 | 0.75   | 1.5    | 2.2    | 3.7    | 5.5   | 7.5   | 11.0  |
| E5-03       | PM Motor Rated Current (FLA)     | A                    | 1.77                                | 3.13   | 5.73   | 8.44   | 13.96  | 20.63 | 28.13 | 41.4  |
| E5-04       | PM Motor Pole Count              | -                    | 6                                   | 6      | 6      | 6      | 6      | 6     | 6     | 6     |
| E5-05       | PM Motor Resistance (ohms/phase) | Ω                    | 8.233                               | 2.284  | 1.470  | 0.827  | 0.455  | 0.246 | 0.198 | 0.094 |
| E5-06       | PM d-axis Inductance (mH/phase)  | mH                   | 54.84                               | 23.02  | 17.22  | 8.61   | 7.20   | 4.86  | 4.15  | 3.40  |
| E5-07       | PM q-axis Inductance (mH/phase)  | mH                   | 64.10                               | 29.89  | 20.41  | 13.50  | 10.02  | 7.43  | 5.91  | 3.91  |
| E5-09       | PM Back-EMF Vpeak (mV/(rad/s))   | mVs/rad              | 223.7                               | 220.3  | 240.8  | 238.0  | 238.7  | 239.6 | 258.2 | 239.3 |
| E5-24       | PM Back-EMF L-L Vrms (mV/rpm)    | mV/min <sup>-1</sup> | 0.0                                 | 0.0    | 0.0    | 0.0    | 0.0    | 0.0   | 0.0   | 0.0   |
| E1-04       | Maximum Output Frequency         | Hz                   | 87.5                                | 87.5   | 87.5   | 87.5   | 87.5   | 87.5  | 87.5  | 87.5  |
| E1-05       | Maximum Output Voltage           | V                    | 190.0                               | 190.0  | 190.0  | 190.0  | 190.0  | 190.0 | 190.0 | 190.0 |
| E1-06       | Base Frequency                   | Hz                   | 87.5                                | 87.5   | 87.5   | 87.5   | 87.5   | 87.5  | 87.5  | 87.5  |
| E1-09       | Minimum Output Frequency         | Hz                   | 4.4                                 | 4.4    | 4.4    | 4.4    | 4.4    | 4.4   | 4.4   | 4.4   |
| C5-17       | Motor Inertia                    | kgm <sup>2</sup>     | 0.0011                              | 0.0017 | 0.0023 | 0.0043 | 0.0083 | 0.014 | 0.017 | 0.027 |
| L3-24<br>*1 | Motor Accel Time @ Rated Torque  | s                    | 0.092                               | 0.076  | 0.051  | 0.066  | 0.075  | 0.083 | 0.077 | 0.084 |
| n5-02       | Motor Inertia Acceleration Time  | s                    | 0.092                               | 0.076  | 0.051  | 0.066  | 0.075  | 0.083 | 0.077 | 0.084 |
| n8-49       | Heavy Load Id Current            | %                    | -7.6                                | -11.5  | -9.1   | -19.0  | -18.7  | -23.4 | -18.5 | -10.9 |

\*1 The default setting changes when the setting for o2-04 [Drive Model Selection] changes.

## 1.22 Parameters Changed by PM Motor Code Selection

**Table 1.7 SSR1 Series Motor Code Setting for Specification of 200 V at 1750 min<sup>-1</sup> (r/min)**

| No.      | Name                             | Unit                 | Motor Code (setting value of E5-01) |       |       |       |       |       |       |       |
|----------|----------------------------------|----------------------|-------------------------------------|-------|-------|-------|-------|-------|-------|-------|
|          |                                  |                      | 120E                                | 120F  | 1210  | 1212  | 1213  | 1214  | 1215  | 1216  |
| E5-01    | PM Motor Code Selection          | -                    | 120E                                | 120F  | 1210  | 1212  | 1213  | 1214  | 1215  | 1216  |
|          | Voltage Class                    | V                    | 200                                 | 200   | 200   | 200   | 200   | 200   | 200   | 200   |
|          | Capacity                         | kW                   | 15                                  | 18    | 22    | 30    | 37    | 45    | 55    | 75    |
|          | Motor Rotation Speed             | min <sup>-1</sup>    | 1750                                | 1750  | 1750  | 1750  | 1750  | 1750  | 1750  | 1750  |
| E5-02    | PM Motor Rated Power             | kW                   | 15.00                               | 18.50 | 22.00 | 30.00 | 37.00 | 45.00 | 55.00 | 75.00 |
| E5-03    | PM Motor Rated Current (FLA)     | A                    | 55.4                                | 68.2  | 80.6  | 105.2 | 131.3 | 153.1 | 185.4 | 257.3 |
| E5-04    | PM Motor Pole Count              | -                    | 6                                   | 6     | 6     | 6     | 6     | 6     | 6     | 6     |
| E5-05    | PM Motor Resistance (ohms/phase) | Ω                    | 0.066                               | 0.051 | 0.037 | 0.030 | 0.020 | 0.014 | 0.012 | 0.006 |
| E5-06    | PM d-axis Inductance (mH/phase)  | mH                   | 2.45                                | 2.18  | 1.71  | 1.35  | 0.99  | 0.83  | 0.79  | 0.44  |
| E5-07    | PM q-axis Inductance (mH/phase)  | mH                   | 3.11                                | 2.55  | 2.05  | 1.82  | 1.28  | 1.01  | 0.97  | 0.56  |
| E5-09    | PM Back-EMF Vpeak (mV/(rad/s))   | mVs/rad              | 248.1                               | 253.6 | 250.0 | 280.9 | 264.2 | 280.4 | 311.9 | 268.0 |
| E5-24    | PM Back-EMF L-L Vrms (mV/rpm)    | mV/min <sup>-1</sup> | 0.0                                 | 0.0   | 0.0   | 0.0   | 0.0   | 0.0   | 0.0   | 0.0   |
| E1-04    | Maximum Output Frequency         | Hz                   | 87.5                                | 87.5  | 87.5  | 87.5  | 87.5  | 87.5  | 87.5  | 87.5  |
| E1-05    | Maximum Output Voltage           | V                    | 190.0                               | 190.0 | 190.0 | 190.0 | 190.0 | 190.0 | 190.0 | 190.0 |
| E1-06    | Base Frequency                   | Hz                   | 87.5                                | 87.5  | 87.5  | 87.5  | 87.5  | 87.5  | 87.5  | 87.5  |
| E1-09    | Minimum Output Frequency         | Hz                   | 4.4                                 | 4.4   | 4.4   | 4.4   | 4.4   | 4.4   | 4.4   | 4.4   |
| C5-17    | Motor Inertia                    | kgm <sup>2</sup>     | 0.046                               | 0.055 | 0.064 | 0.116 | 0.140 | 0.259 | 0.31  | 0.42  |
| L3-24 *1 | Motor Accel Time @ Rated Torque  | s                    | 0.102                               | 0.101 | 0.098 | 0.130 | 0.127 | 0.193 | 0.191 | 0.187 |
| n5-02    | Motor Inertia Acceleration Time  | s                    | 0.102                               | 0.101 | 0.098 | 0.130 | 0.127 | 0.193 | 0.191 | 0.187 |
| n8-49    | Heavy Load Id Current            | %                    | -16.5                               | -11.3 | -12.8 | -16.8 | -15.6 | -10.7 | -9.6  | -13.3 |

\*1 The default setting changes when the setting for o2-04 [Drive Model Selection] changes.

**Table 1.8 SSR1 Series Motor Code Setting for Specification of 400 V at 1750 min<sup>-1</sup> (r/min)**

| No.   | Name                             | Unit              | Motor Code (setting value of E5-01) |        |       |       |       |       |       |       |
|-------|----------------------------------|-------------------|-------------------------------------|--------|-------|-------|-------|-------|-------|-------|
|       |                                  |                   | 1232                                | 1233   | 1235  | 1236  | 1238  | 123A  | 123B  | 123D  |
| E5-01 | PM Motor Code Selection          | -                 | 1232                                | 1233   | 1235  | 1236  | 1238  | 123A  | 123B  | 123D  |
|       | Voltage Class                    | V                 | 400                                 | 400    | 400   | 400   | 400   | 400   | 400   | 400   |
|       | Capacity                         | kW                | 0.4                                 | 0.75   | 1.5   | 2.2   | 3.7   | 5.5   | 7.5   | 11    |
|       | Motor Rotation Speed             | min <sup>-1</sup> | 1750                                | 1750   | 1750  | 1750  | 1750  | 1750  | 1750  | 1750  |
| E5-02 | PM Motor Rated Power             | kW                | 0.4                                 | 0.75   | 1.5   | 2.2   | 3.7   | 5.5   | 7.5   | 11.0  |
| E5-03 | PM Motor Rated Current (FLA)     | A                 | 0.89                                | 1.56   | 2.81  | 4.27  | 7.08  | 10.31 | 13.65 | 20.7  |
| E5-04 | PM Motor Pole Count              | -                 | 6                                   | 6      | 6     | 6     | 6     | 6     | 6     | 6     |
| E5-05 | PM Motor Resistance (ohms/phase) | Ω                 | 25.370                              | 9.136  | 6.010 | 3.297 | 1.798 | 0.982 | 0.786 | 0.349 |
| E5-06 | PM d-axis Inductance (mH/phase)  | mH                | 169.00                              | 92.08  | 67.71 | 34.40 | 32.93 | 22.7  | 16.49 | 13.17 |
| E5-07 | PM q-axis Inductance (mH/phase)  | mH                | 197.50                              | 119.56 | 81.71 | 54.00 | 37.70 | 26.80 | 23.46 | 15.60 |
| E5-09 | PM Back-EMF Vpeak (mV/(rad/s))   | mVs/rad           | 392.6                               | 440.6  | 478.3 | 466.3 | 478.8 | 478.1 | 520.0 | 481.5 |

Parameter List

1

## 1.22 Parameters Changed by PM Motor Code Selection

| No.         | Name                            | Unit                 | Motor Code (setting value of E5-01) |        |        |        |        |       |       |       |
|-------------|---------------------------------|----------------------|-------------------------------------|--------|--------|--------|--------|-------|-------|-------|
|             |                                 |                      |                                     |        |        |        |        |       |       |       |
| E5-24       | PM Back-EMF L-L Vrms (mV/rpm)   | mV/min <sup>-1</sup> | 0.0                                 | 0.0    | 0.0    | 0.0    | 0.0    | 0.0   | 0.0   | 0.0   |
| E1-04       | Maximum Output Frequency        | Hz                   | 87.5                                | 87.5   | 87.5   | 87.5   | 87.5   | 87.5  | 87.5  | 87.5  |
| E1-05       | Maximum Output Voltage          | V                    | 380.0                               | 380.0  | 380.0  | 380.0  | 380.0  | 380.0 | 380.0 | 380.0 |
| E1-06       | Base Frequency                  | Hz                   | 87.5                                | 87.5   | 87.5   | 87.5   | 87.5   | 87.5  | 87.5  | 87.5  |
| E1-09       | Minimum Output Frequency        | Hz                   | 4.4                                 | 4.4    | 4.4    | 4.4    | 4.4    | 4.4   | 4.4   | 4.4   |
| C5-17       | Motor Inertia                   | kgm <sup>2</sup>     | 0.0011                              | 0.0017 | 0.0023 | 0.0043 | 0.0083 | 0.014 | 0.017 | 0.027 |
| L3-24<br>*I | Motor Accel Time @ Rated Torque | s                    | 0.092                               | 0.076  | 0.051  | 0.066  | 0.075  | 0.083 | 0.077 | 0.084 |
| n5-02       | Motor Inertia Acceleration Time | s                    | 0.092                               | 0.076  | 0.051  | 0.066  | 0.075  | 0.083 | 0.077 | 0.084 |
| n8-49       | Heavy Load Id Current           | %                    | -8.6                                | -11.5  | -10.3  | -19.8  | -8.5   | -11.0 | -18.6 | -12.5 |

\*1 The default setting changes when the setting for o2-04 [Drive Model Selection] changes.

**Table 1.9 SSR1 Series Motor Code Setting for Specification of 400 V at 1750 min<sup>-1</sup> (r/min)**

| No.         | Name                             | Unit                 | Motor Code (setting value of E5-01) |       |       |       |       |       |       |       |
|-------------|----------------------------------|----------------------|-------------------------------------|-------|-------|-------|-------|-------|-------|-------|
|             |                                  |                      |                                     |       |       |       |       |       |       |       |
| E5-01       | PM Motor Code Selection          | -                    | 123E                                | 123F  | 1240  | 1242  | 1243  | 1244  | 1245  | 1246  |
|             | Voltage Class                    | V                    | 400                                 | 400   | 400   | 400   | 400   | 400   | 400   | 400   |
|             | Capacity                         | kW                   | 15                                  | 18    | 22    | 30    | 37    | 45    | 55    | 75    |
|             | Motor Rotation Speed             | min <sup>-1</sup>    | 1750                                | 1750  | 1750  | 1750  | 1750  | 1750  | 1750  | 1750  |
| E5-02       | PM Motor Rated Power             | kW                   | 15                                  | 18.50 | 22.00 | 30.00 | 37.00 | 45.00 | 55.00 | 75.00 |
| E5-03       | PM Motor Rated Current (FLA)     | A                    | 27.5                                | 33.4  | 39.8  | 52.0  | 65.8  | 77.5  | 92.7  | 126.6 |
| E5-04       | PM Motor Pole Count              | -                    | 6                                   | 6     | 6     | 6     | 6     | 6     | 6     | 6     |
| E5-05       | PM Motor Resistance (ohms/phase) | Ω                    | 0.272                               | 0.207 | 0.148 | 0.235 | 0.079 | 0.054 | 0.049 | 0.029 |
| E5-06       | PM d-axis Inductance (mH/phase)  | mH                   | 10.30                               | 8.72  | 6.81  | 5.4   | 4.08  | 3.36  | 3.16  | 2.12  |
| E5-07       | PM q-axis Inductance (mH/phase)  | mH                   | 12.77                               | 11.22 | 8.47  | 7.26  | 5.12  | 3.94  | 3.88  | 2.61  |
| E5-09       | PM Back-EMF Vpeak (mV/(rad/s))   | mVs/rad              | 498.8                               | 509.5 | 503.9 | 561.7 | 528.5 | 558.1 | 623.8 | 594.5 |
| E5-24       | PM Back-EMF L-L Vrms (mV/rpm)    | mV/min <sup>-1</sup> | 0.0                                 | 0.0   | 0.0   | 0.0   | 0.0   | 0.0   | 0.0   | 0.0   |
| E1-04       | Maximum Output Frequency         | Hz                   | 87.5                                | 87.5  | 87.5  | 87.5  | 87.5  | 87.5  | 87.5  | 87.5  |
| E1-05       | Maximum Output Voltage           | V                    | 380.0                               | 380.0 | 380.0 | 380.0 | 380.0 | 380.0 | 380.0 | 380.0 |
| E1-06       | Base Frequency                   | Hz                   | 87.5                                | 87.5  | 87.5  | 87.5  | 87.5  | 87.5  | 87.5  | 87.5  |
| E1-09       | Minimum Output Frequency         | Hz                   | 4.4                                 | 4.4   | 4.4   | 4.4   | 4.4   | 4.4   | 4.4   | 4.4   |
| C5-17       | Motor Inertia                    | kgm <sup>2</sup>     | 0.046                               | 0.055 | 0.064 | 0.116 | 0.140 | 0.259 | 0.31  | 0.42  |
| L3-24<br>*I | Motor Accel Time @ Rated Torque  | s                    | 0.102                               | 0.101 | 0.098 | 0.130 | 0.127 | 0.193 | 0.191 | 0.187 |
| n5-02       | Motor Inertia Acceleration Time  | s                    | 0.102                               | 0.101 | 0.098 | 0.130 | 0.127 | 0.193 | 0.191 | 0.187 |
| n8-49       | Heavy Load Id Current            | %                    | -15.5                               | -17.9 | -15.1 | -16.8 | -14.1 | -8.8  | -9.6  | -10.3 |

\*1 The default setting changes when the setting for o2-04 [Drive Model Selection] changes.



## 1.22 Parameters Changed by PM Motor Code Selection

**Table 1.10 SSR1 Series Motor Code Setting for Specification of 400 V at 1750 min<sup>-1</sup> (r/min)**

| No.         | Name                                       | Unit                 | Motor Code (setting value of E5-01) |        |        |        |
|-------------|--|----------------------|-------------------------------------|--------|--------|--------|
| E5-01       | PM Motor Code Selection                    | -                    | 1247                                | 1248   | 1249   | 124A   |
|             | Voltage Class                              | V                    | 400                                 | 400    | 400    | 400    |
|             | Capacity                                   | kW                   | 90                                  | 110    | 132    | 160    |
|             | Motor Rotation Speed                       | min <sup>-1</sup>    | 1750                                | 1750   | 1750   | 1750   |
| E5-02       | PM Motor Rated Power                       | kW                   | 90.00                               | 110.00 | 132.00 | 160.00 |
| E5-03       | PM Motor Rated Current (FLA)               | A                    | 160.4                               | 183.3  | 222.9  | 267.7  |
| E5-04       | PM Motor Pole Count                        | -                    | 6                                   | 6      | 6      | 6      |
| E5-05       | PM Motor Resistance (ohms/phase)           | Ω                    | 0.019                               | 0.017  | 0.012  | 0.008  |
| E5-06       | PM d-axis Inductance (mH/phase)            | mH                   | 1.54                                | 1.44   | 1.21   | 0.97   |
| E5-07       | PM q-axis Inductance (mH/phase)            | mH                   | 2.06                                | 2.21   | 1.46   | 1.28   |
| E5-09       | PM Back-EMF V <sub>peak</sub> (mV/(rad/s)) | mVs/rad              | 524.1                               | 583.7  | 563.6  | 601.2  |
| E5-24       | PM Back-EMF L-L V <sub>rms</sub> (mV/rpm)  | mV/min <sup>-1</sup> | 0.0                                 | 0.0    | 0.0    | 0.0    |
| E1-04       | Maximum Output Frequency                   | Hz                   | 87.5                                | 87.5   | 87.5   | 87.5   |
| E1-05       | Maximum Output Voltage                     | V                    | 380.0                               | 380.0  | 380.0  | 380.0  |
| E1-06       | Base Frequency                             | Hz                   | 87.5                                | 87.5   | 87.5   | 87.5   |
| E1-09       | Minimum Output Frequency                   | Hz                   | 4.4                                 | 4.4    | 4.4    | 4.4    |
| C5-17       | Motor Inertia                              | kgm <sup>2</sup>     | 0.56                                | 0.83   | 0.96   | 1.61   |
| L3-24<br>*1 | Motor Accel Time @ Rated Torque            | s                    | 0.208                               | 0.254  | 0.243  | 0.338  |
| n5-02       | Motor Inertia Acceleration Time            | s                    | 0.208                               | 0.254  | 0.243  | 0.338  |
| n8-49       | Heavy Load Id Current                      | %                    | -17.0                               | -21.7  | -10.9  | -13.2  |

\*1 The default setting changes when the setting for o2-04 [Drive Model Selection] changes.

**Table 1.11 SSR1 Series Motor Code Setting for Specification of 200 V at 1450 min<sup>-1</sup> (r/min)**

| No.   | Name                                       | Unit                 | Motor Code (setting value of E5-01) |       |       |       |       |       |       |       |
|-------|--|----------------------|-------------------------------------|-------|-------|-------|-------|-------|-------|-------|
| E5-01 | PM Motor Code Selection                    | -                    | 1302                                | 1303  | 1305  | 1306  | 1308  | 130A  | 130B  | 130D  |
|       | Voltage Class                              | V                    | 200                                 | 200   | 200   | 200   | 200   | 200   | 200   | 200   |
|       | Capacity                                   | kW                   | 0.4                                 | 0.75  | 1.5   | 2.2   | 3.7   | 5.5   | 7.5   | 11    |
|       | Motor Rotation Speed                       | min <sup>-1</sup>    | 1450                                | 1450  | 1450  | 1450  | 1450  | 1450  | 1450  | 1450  |
| E5-02 | PM Motor Rated Power                       | kW                   | 0.4                                 | 0.75  | 1.5   | 2.2   | 3.7   | 5.5   | 7.5   | 11.0  |
| E5-03 | PM Motor Rated Current (FLA)               | A                    | 1.88                                | 3.13  | 5.63  | 8.33  | 14.17 | 20.63 | 27.71 | 39.6  |
| E5-04 | PM Motor Pole Count                        | -                    | 6                                   | 6     | 6     | 6     | 6     | 6     | 6     | 6     |
| E5-05 | PM Motor Resistance (ohms/phase)           | Ω                    | 3.190                               | 1.940 | 1.206 | 0.665 | 0.341 | 0.252 | 0.184 | 0.099 |
| E5-06 | PM d-axis Inductance (mH/phase)            | mH                   | 32.15                               | 26.12 | 14.72 | 12.27 | 8.27  | 6.49  | 6.91  | 4.07  |
| E5-07 | PM q-axis Inductance (mH/phase)            | mH                   | 41.74                               | 34.30 | 20.15 | 14.77 | 9.81  | 7.74  | 7.66  | 4.65  |
| E5-09 | PM Back-EMF V <sub>peak</sub> (mV/(rad/s)) | mVs/rad              | 264.3                               | 269.6 | 284.3 | 287.1 | 284.5 | 298.0 | 335.0 | 303.9 |
| E5-24 | PM Back-EMF L-L V <sub>rms</sub> (mV/rpm)  | mV/min <sup>-1</sup> | 0.0                                 | 0.0   | 0.0   | 0.0   | 0.0   | 0.0   | 0.0   | 0.0   |
| E1-04 | Maximum Output Frequency                   | Hz                   | 72.5                                | 72.5  | 72.5  | 72.5  | 72.5  | 72.5  | 72.5  | 72.5  |
| E1-05 | Maximum Output Voltage                     | V                    | 190.0                               | 190.0 | 190.0 | 190.0 | 190.0 | 190.0 | 190.0 | 190.0 |
| E1-06 | Base Frequency                             | Hz                   | 72.5                                | 72.5  | 72.5  | 72.5  | 72.5  | 72.5  | 72.5  | 72.5  |

Parameter List

1

## 1.22 Parameters Changed by PM Motor Code Selection

| No.         | Name                            | Unit             | Motor Code (setting value of E5-01) |        |        |        |        |       |       |       |
|-------------|---------------------------------|------------------|-------------------------------------|--------|--------|--------|--------|-------|-------|-------|
|             |                                 |                  |                                     |        |        |        |        |       |       |       |
| E1-09       | Minimum Output Frequency        | Hz               | 3.6                                 | 3.6    | 3.6    | 3.6    | 3.6    | 3.6   | 3.6   | 3.6   |
| C5-17       | Motor Inertia                   | kgm <sup>2</sup> | 0.0017                              | 0.0023 | 0.0043 | 0.0083 | 0.0136 | 0.017 | 0.027 | 0.046 |
| L3-24<br>*I | Motor Accel Time @ Rated Torque | s                | 0.098                               | 0.071  | 0.066  | 0.087  | 0.085  | 0.072 | 0.084 | 0.096 |
| n5-02       | Motor Inertia Acceleration Time | s                | 0.098                               | 0.071  | 0.066  | 0.087  | 0.085  | 0.072 | 0.084 | 0.096 |
| n8-49       | Heavy Load Id Current           | %                | -6.6                                | -10.9  | -13.5  | -9.0   | -9.5   | -10.1 | -6.0  | -9.3  |

\*1 The default setting changes when the setting for o2-04 [Drive Model Selection] changes.

**Table 1.12 SSR1 Series Motor Code Setting for Specification of 200 V at 1450 min<sup>-1</sup> (r/min)**

| No.         | Name                             | Unit                 | Motor Code (setting value of E5-01) |       |       |       |       |       |       |  |
|-------------|----------------------------------|----------------------|-------------------------------------|-------|-------|-------|-------|-------|-------|--|
|             |                                  |                      |                                     |       |       |       |       |       |       |  |
| E5-01       | PM Motor Code Selection          | -                    | 130E                                | 130F  | 1310  | 1312  | 1313  | 1314  | 1315  |  |
|             | Voltage Class                    | V                    | 200                                 | 200   | 200   | 200   | 200   | 200   | 200   |  |
|             | Capacity                         | kW                   | 15                                  | 18    | 22    | 30    | 37    | 45    | 55    |  |
|             | Motor Rotation Speed             | min <sup>-1</sup>    | 1450                                | 1450  | 1450  | 1450  | 1450  | 1450  | 1450  |  |
| E5-02       | PM Motor Rated Power             | kW                   | 15.00                               | 18.50 | 22.00 | 30.00 | 37.00 | 45.00 | 55.00 |  |
| E5-03       | PM Motor Rated Current (FLA)     | A                    | 55.5                                | 65.6  | 75.1  | 105.2 | 126.0 | 153.1 | 186.5 |  |
| E5-04       | PM Motor Pole Count              | -                    | 6                                   | 6     | 6     | 6     | 6     | 6     | 6     |  |
| E5-05       | PM Motor Resistance (ohms/phase) | Ω                    | 0.075                               | 0.057 | 0.041 | 0.034 | 0.023 | 0.015 | 0.012 |  |
| E5-06       | PM d-axis Inductance (mH/phase)  | mH                   | 3.29                                | 2.53  | 1.98  | 1.75  | 1.48  | 1.04  | 0.87  |  |
| E5-07       | PM q-axis Inductance (mH/phase)  | mH                   | 3.84                                | 3.01  | 2.60  | 2.17  | 1.70  | 1.31  | 1.10  |  |
| E5-09       | PM Back-EMF Vpeak (mV/(rad/s))   | mVs/rad              | 311.2                               | 300.9 | 327.7 | 354.2 | 369.6 | 351.6 | 374.7 |  |
| E5-24       | PM Back-EMF L-L Vrms (mV/rpm)    | mV/min <sup>-1</sup> | 0.0                                 | 0.0   | 0.0   | 0.0   | 0.0   | 0.0   | 0.0   |  |
| E1-04       | Maximum Output Frequency         | Hz                   | 72.5                                | 72.5  | 72.5  | 72.5  | 72.5  | 72.5  | 72.5  |  |
| E1-05       | Maximum Output Voltage           | V                    | 190.0                               | 190.0 | 190.0 | 190.0 | 190.0 | 190.0 | 190.0 |  |
| E1-06       | Base Frequency                   | Hz                   | 72.5                                | 72.5  | 72.5  | 72.5  | 72.5  | 72.5  | 72.5  |  |
| E1-09       | Minimum Output Frequency         | Hz                   | 3.6                                 | 3.6   | 3.6   | 3.6   | 3.6   | 3.6   | 3.6   |  |
| C5-17       | Motor Inertia                    | kgm <sup>2</sup>     | 0.055                               | 0.064 | 0.116 | 0.140 | 0.259 | 0.312 | 0.42  |  |
| L3-24<br>*I | Motor Accel Time @ Rated Torque  | s                    | 0.085                               | 0.080 | 0.122 | 0.108 | 0.161 | 0.160 | 0.175 |  |
| n5-02       | Motor Inertia Acceleration Time  | s                    | 0.085                               | 0.080 | 0.122 | 0.108 | 0.161 | 0.160 | 0.175 |  |
| n8-49       | Heavy Load Id Current            | %                    | -10.7                               | -13.2 | -15.7 | -11.5 | -7.0  | -11.8 | -10.2 |  |

\*1 The default setting changes when the setting for o2-04 [Drive Model Selection] changes.

**Table 1.13 SSR1 Series Motor Code Setting for Specification of 400 V at 1450 min<sup>-1</sup> (r/min)**

| No.   | Name                    | Unit              | Motor Code (setting value of E5-01) |      |      |      |      |      |      |      |
|-------|-------------------------|-------------------|-------------------------------------|------|------|------|------|------|------|------|
|       |                         |                   |                                     |      |      |      |      |      |      |      |
| E5-01 | PM Motor Code Selection | -                 | 1332                                | 1333 | 1335 | 1336 | 1338 | 133A | 133B | 133D |
|       | Voltage Class           | V                 | 400                                 | 400  | 400  | 400  | 400  | 400  | 400  | 400  |
|       | Capacity                | kW                | 0.4                                 | 0.75 | 1.5  | 2.2  | 3.7  | 5.5  | 7.5  | 11   |
|       | Motor Rotation Speed    | min <sup>-1</sup> | 1450                                | 1450 | 1450 | 1450 | 1450 | 1450 | 1450 | 1450 |
| E5-02 | PM Motor Rated Power    | kW                | 0.4                                 | 0.75 | 1.5  | 2.2  | 3.7  | 5.5  | 7.5  | 11.0 |

## 1.22 Parameters Changed by PM Motor Code Selection

| No.         | Name                             | Unit                 | Motor Code (setting value of E5-01) |        |        |        |        |       |       |       |
|-------------|----------------------------------|----------------------|-------------------------------------|--------|--------|--------|--------|-------|-------|-------|
|             |                                  |                      |                                     |        |        |        |        |       |       |       |
| E5-03       | PM Motor Rated Current (FLA)     | A                    | 0.94                                | 1.56   | 2.81   | 4.27   | 6.98   | 10.21 | 13.85 | 19.5  |
| E5-04       | PM Motor Pole Count              | -                    | 6                                   | 6      | 6      | 6      | 6      | 6     | 6     | 6     |
| E5-05       | PM Motor Resistance (ohms/phase) | Ω                    | 12.760                              | 7.421  | 4.825  | 2.656  | 1.353  | 0.999 | 0.713 | 0.393 |
| E5-06       | PM d-axis Inductance (mH/phase)  | mH                   | 128.60                              | 85.11  | 58.87  | 46.42  | 31.73  | 26.20 | 27.06 | 15.51 |
| E5-07       | PM q-axis Inductance (mH/phase)  | mH                   | 166.96                              | 113.19 | 80.59  | 60.32  | 40.45  | 30.94 | 33.45 | 19.63 |
| E5-09       | PM Back-EMF Vpeak (mV/(rad/s))   | mVs/rad              | 528.6                               | 544.2  | 568.5  | 572.8  | 562.9  | 587.6 | 670.1 | 612.7 |
| E5-24       | PM Back-EMF L-L Vrms (mV/rpm)    | mV/min <sup>-1</sup> | 0.0                                 | 0.0    | 0.0    | 0.0    | 0.0    | 0.0   | 0.0   | 0.0   |
| E1-04       | Maximum Output Frequency         | Hz                   | 72.5                                | 72.5   | 72.5   | 72.5   | 72.5   | 72.5  | 72.5  | 72.5  |
| E1-05       | Maximum Output Voltage           | V                    | 380.0                               | 380.0  | 380.0  | 380.0  | 380.0  | 380.0 | 380.0 | 380.0 |
| E1-06       | Base Frequency                   | Hz                   | 72.5                                | 72.5   | 72.5   | 72.5   | 72.5   | 72.5  | 72.5  | 72.5  |
| E1-09       | Minimum Output Frequency         | Hz                   | 3.6                                 | 3.6    | 3.6    | 3.6    | 3.6    | 3.6   | 3.6   | 3.6   |
| C5-17       | Motor Inertia                    | kgm <sup>2</sup>     | 0.0017                              | 0.0023 | 0.0043 | 0.0083 | 0.0136 | 0.017 | 0.027 | 0.046 |
| L3-24<br>*1 | Motor Accel Time @ Rated Torque  | s                    | 0.098                               | 0.071  | 0.066  | 0.087  | 0.085  | 0.072 | 0.084 | 0.096 |
| n5-02       | Motor Inertia Acceleration Time  | s                    | 0.098                               | 0.071  | 0.066  | 0.087  | 0.085  | 0.072 | 0.084 | 0.096 |
| n8-49       | Heavy Load Id Current            | %                    | -6.6                                | -9.2   | -13.5  | -12.1  | -13.7  | -10.1 | -12.2 | -15.5 |

\*1 The default setting changes when the setting for o2-04 [Drive Model Selection] changes.

**Table 1.14 SSR1 Series Motor Code Setting for Specification of 400 V at 1450 min<sup>-1</sup> (r/min)**

| No.   | Name                             | Unit                 | Motor Code (setting value of E5-01) |       |       |       |       |       |       |  |
|-------|----------------------------------|----------------------|-------------------------------------|-------|-------|-------|-------|-------|-------|--|
|       |                                  |                      |                                     |       |       |       |       |       |       |  |
| E5-01 | PM Motor Code Selection          | -                    | 133E                                | 133F  | 1340  | 1342  | 1343  | 1344  | 1345  |  |
|       | Voltage Class                    | V                    | 400                                 | 400   | 400   | 400   | 400   | 400   | 400   |  |
|       | Capacity                         | kW                   | 15                                  | 18    | 22    | 30    | 37    | 45    | 55    |  |
|       | Motor Rotation Speed             | min <sup>-1</sup>    | 1450                                | 1450  | 1450  | 1450  | 1450  | 1450  | 1450  |  |
| E5-02 | PM Motor Rated Power             | kW                   | 15                                  | 18.50 | 22.00 | 30.00 | 37.00 | 45.00 | 55.00 |  |
| E5-03 | PM Motor Rated Current (FLA)     | A                    | 27.4                                | 32.9  | 37.6  | 52.5  | 63.2  | 76.4  | 96.1  |  |
| E5-04 | PM Motor Pole Count              | -                    | 6                                   | 6     | 6     | 6     | 6     | 6     | 6     |  |
| E5-05 | PM Motor Resistance (ohms/phase) | Ω                    | 0.295                               | 0.223 | 0.164 | 0.137 | 0.093 | 0.059 | 0.048 |  |
| E5-06 | PM d-axis Inductance (mH/phase)  | mH                   | 12.65                               | 9.87  | 7.90  | 7.01  | 5.93  | 4.17  | 3.11  |  |
| E5-07 | PM q-axis Inductance (mH/phase)  | mH                   | 15.87                               | 12.40 | 10.38 | 8.68  | 6.79  | 5.22  | 4.55  |  |
| E5-09 | PM Back-EMF Vpeak (mV/(rad/s))   | mVs/rad              | 624.6                               | 610.4 | 655.4 | 708.4 | 739.2 | 703.0 | 747.1 |  |
| E5-24 | PM Back-EMF L-L Vrms (mV/rpm)    | mV/min <sup>-1</sup> | 0.0                                 | 0.0   | 0.0   | 0.0   | 0.0   | 0.0   | 0.0   |  |
| E1-04 | Maximum Output Frequency         | Hz                   | 72.5                                | 72.5  | 72.5  | 72.5  | 72.5  | 72.5  | 72.5  |  |
| E1-05 | Maximum Output Voltage           | V                    | 380.0                               | 380.0 | 380.0 | 380.0 | 380.0 | 380.0 | 380.0 |  |
| E1-06 | Base Frequency                   | Hz                   | 72.5                                | 72.5  | 72.5  | 72.5  | 72.5  | 72.5  | 72.5  |  |
| E1-09 | Minimum Output Frequency         | Hz                   | 3.6                                 | 3.6   | 3.6   | 3.6   | 3.6   | 3.6   | 3.6   |  |
| C5-17 | Motor Inertia                    | kgm <sup>2</sup>     | 0.055                               | 0.064 | 0.116 | 0.140 | 0.259 | 0.312 | 0.42  |  |

Parameter List

1

## 1.22 Parameters Changed by PM Motor Code Selection

| No.         | Name                            | Unit | Motor Code (setting value of E5-01) |       |       |       |       |       |       |
|-------------|---------------------------------|------|-------------------------------------|-------|-------|-------|-------|-------|-------|
|             |                                 |      |                                     |       |       |       |       |       |       |
| L3-24<br>*J | Motor Accel Time @ Rated Torque | s    | 0.085                               | 0.080 | 0.122 | 0.108 | 0.161 | 0.160 | 0.175 |
| n5-02       | Motor Inertia Acceleration Time | s    | 0.085                               | 0.080 | 0.122 | 0.108 | 0.161 | 0.160 | 0.175 |
| n8-49       | Heavy Load Id Current           | %    | -15.1                               | -16.0 | -15.7 | -11.5 | -6.8  | -11.5 | -14.8 |

\*1 The default setting changes when the setting for o2-04 [Drive Model Selection] changes.

**Table 1.15 SSR1 Series Motor Code Setting for Specification of 400 V at 1450 min<sup>-1</sup> (r/min)**

| No.         | Name                                       | Unit                 | Motor Code (setting value of E5-01) |       |        |        |
|-------------|--|----------------------|-------------------------------------|-------|--------|--------|
|             |  |                      |                                     |       |        |        |
| E5-01       | PM Motor Code Selection                    | -                    | 1346                                | 1347  | 1348   | 1349   |
|             | Voltage Class                              | V                    | 400                                 | 400   | 400    | 400    |
|             | Capacity                                   | kW                   | 75                                  | 90    | 110    | 132    |
|             | Motor Rotation Speed                       | min <sup>-1</sup>    | 1450                                | 1450  | 1450   | 1450   |
| E5-02       | PM Motor Rated Power                       | kW                   | 75.00                               | 90.00 | 110.00 | 132.00 |
| E5-03       | PM Motor Rated Current (FLA)               | A                    | 124.0                               | 153.1 | 186.5  | 226.0  |
| E5-04       | PM Motor Pole Count                        | -                    | 6                                   | 6     | 6      | 6      |
| E5-05       | PM Motor Resistance (ohms/phase)           | Ω                    | 0.028                               | 0.024 | 0.015  | 0.011  |
| E5-06       | PM d-axis Inductance (mH/phase)            | mH                   | 2.32                                | 2.20  | 1.45   | 1.23   |
| E5-07       | PM q-axis Inductance (mH/phase)            | mH                   | 2.97                                | 3.23  | 1.88   | 1.67   |
| E5-09       | PM Back-EMF V <sub>peak</sub> (mV/(rad/s)) | mVs/rad              | 639.3                               | 708.0 | 640.7  | 677.0  |
| E5-24       | PM Back-EMF L-L V <sub>rms</sub> (mV/rpm)  | mV/min <sup>-1</sup> | 0.0                                 | 0.0   | 0.0    | 0.0    |
| E1-04       | Maximum Output Frequency                   | Hz                   | 72.5                                | 72.5  | 72.5   | 72.5   |
| E1-05       | Maximum Output Voltage                     | V                    | 380.0                               | 380.0 | 380.0  | 380.0  |
| E1-06       | Base Frequency                             | Hz                   | 72.5                                | 72.5  | 72.5   | 72.5   |
| E1-09       | Minimum Output Frequency                   | Hz                   | 3.6                                 | 3.6   | 3.6    | 3.6    |
| C5-17       | Motor Inertia                              | kgm <sup>2</sup>     | 0.56                                | 0.83  | 0.96   | 1.61   |
| L3-24<br>*J | Motor Accel Time @ Rated Torque            | s                    | 0.171                               | 0.213 | 0.201  | 0.281  |
| n5-02       | Motor Inertia Acceleration Time            | s                    | 0.171                               | 0.213 | 0.201  | 0.281  |
| n8-49       | Heavy Load Id Current                      | %                    | -15.8                               | -19.6 | -14.9  | -15.1  |

\*1 The default setting changes when the setting for o2-04 [Drive Model Selection] changes.

**Table 1.16 SSR1 Series Motor Code Setting for Specification of 200 V at 1150 min<sup>-1</sup> (r/min)**

| No.   | Name                             | Unit              | Motor Code (setting value of E5-01) |       |       |       |       |       |       |       |
|-------|----------------------------------|-------------------|-------------------------------------|-------|-------|-------|-------|-------|-------|-------|
|       |                                  |                   |                                     |       |       |       |       |       |       |       |
| E5-01 | PM Motor Code Selection          | -                 | 1402                                | 1403  | 1405  | 1406  | 1408  | 140A  | 140B  | 140D  |
|       | Voltage Class                    | V                 | 200                                 | 200   | 200   | 200   | 200   | 200   | 200   | 200   |
|       | Capacity                         | kW                | 0.4                                 | 0.75  | 1.5   | 2.2   | 3.7   | 5.5   | 7.5   | 11    |
|       | Motor Rotation Speed             | min <sup>-1</sup> | 1150                                | 1150  | 1150  | 1150  | 1150  | 1150  | 1150  | 1150  |
| E5-02 | PM Motor Rated Power             | kW                | 0.4                                 | 0.75  | 1.5   | 2.2   | 3.7   | 5.5   | 7.5   | 11.0  |
| E5-03 | PM Motor Rated Current (FLA)     | A                 | 1.88                                | 3.02  | 6.00  | 8.85  | 14.27 | 20.21 | 26.67 | 39.9  |
| E5-04 | PM Motor Pole Count              | -                 | 6                                   | 6     | 6     | 6     | 6     | 6     | 6     | 6     |
| E5-05 | PM Motor Resistance (ohms/phase) | Ω                 | 4.832                               | 2.704 | 1.114 | 0.511 | 0.412 | 0.303 | 0.165 | 0.113 |
| E5-06 | PM d-axis Inductance (mH/phase)  | mH                | 48.68                               | 32.31 | 19.22 | 12.15 | 7.94  | 11.13 | 6.59  | 4.96  |
| E5-07 | PM q-axis Inductance (mH/phase)  | mH                | 63.21                               | 40.24 | 24.38 | 15.35 | 11.86 | 14.06 | 8.55  | 6.12  |

## 1.22 Parameters Changed by PM Motor Code Selection

| No.         | Name                            | Unit                 | Motor Code (setting value of E5-01) |        |        |        |        |       |       |       |
|-------------|---------------------------------|----------------------|-------------------------------------|--------|--------|--------|--------|-------|-------|-------|
|             |                                 |                      |                                     |        |        |        |        |       |       |       |
| E5-09       | PM Back-EMF Vpeak (mV/(rad/s))  | mVs/rad              | 320.4                               | 327.1  | 364.4  | 344.4  | 357.5  | 430.8 | 391.5 | 384.4 |
| E5-24       | PM Back-EMF L-L Vrms (mV/rpm)   | mV/min <sup>-1</sup> | 0.0                                 | 0.0    | 0.0    | 0.0    | 0.0    | 0.0   | 0.0   | 0.0   |
| E1-04       | Maximum Output Frequency        | Hz                   | 57.5                                | 57.5   | 57.5   | 57.5   | 57.5   | 57.5  | 57.5  | 57.5  |
| E1-05       | Maximum Output Voltage          | V                    | 190.0                               | 190.0  | 190.0  | 190.0  | 190.0  | 190.0 | 190.0 | 190.0 |
| E1-06       | Base Frequency                  | Hz                   | 57.5                                | 57.5   | 57.5   | 57.5   | 57.5   | 57.5  | 57.5  | 57.5  |
| E1-09       | Minimum Output Frequency        | Hz                   | 2.9                                 | 2.9    | 2.9    | 2.9    | 2.9    | 2.9   | 2.9   | 2.9   |
| C5-17       | Motor Inertia                   | kgm <sup>2</sup>     | 0.0017                              | 0.0023 | 0.0083 | 0.0136 | 0.0171 | 0.027 | 0.046 | 0.055 |
| L3-24<br>*J | Motor Accel Time @ Rated Torque | s                    | 0.062                               | 0.044  | 0.080  | 0.090  | 0.067  | 0.072 | 0.088 | 0.073 |
| n5-02       | Motor Inertia Acceleration Time | s                    | 0.062                               | 0.044  | 0.080  | 0.090  | 0.067  | 0.072 | 0.088 | 0.073 |
| n8-49       | Heavy Load Id Current           | %                    | -8.8                                | -9.9   | -9.3   | -10.0  | -17.7  | -12.3 | -15.3 | -13.9 |

\*1 The default setting changes when the setting for o2-04 [Drive Model Selection] changes.

**Table 1.17 SSR1 Series Motor Code Setting for Specification of 200 V at 1150 min<sup>-1</sup> (r/min)**

| No.         | Name                             | Unit                 | Motor Code (setting value of E5-01) |       |       |       |       |       |  |  |
|-------------|----------------------------------|----------------------|-------------------------------------|-------|-------|-------|-------|-------|--|--|
|             |                                  |                      |                                     |       |       |       |       |       |  |  |
| E5-01       | PM Motor Code Selection          | -                    | 140E                                | 140F  | 1410  | 1412  | 1413  | 1414  |  |  |
|             | Voltage Class                    | V                    | 200                                 | 200   | 200   | 200   | 200   | 200   |  |  |
|             | Capacity                         | kW                   | 15                                  | 18    | 22    | 30    | 37    | 45    |  |  |
|             | Motor Rotation Speed             | min <sup>-1</sup>    | 1150                                | 1150  | 1150  | 1150  | 1150  | 1150  |  |  |
| E5-02       | PM Motor Rated Power             | kW                   | 15                                  | 18.50 | 22.00 | 30.00 | 37.00 | 45.00 |  |  |
| E5-03       | PM Motor Rated Current (FLA)     | A                    | 55.6                                | 63.5  | 74.4  | 104.2 | 129.6 | 154.2 |  |  |
| E5-04       | PM Motor Pole Count              | -                    | 6                                   | 6     | 6     | 6     | 6     | 6     |  |  |
| E5-05       | PM Motor Resistance (ohms/phase) | Ω                    | 0.084                               | 0.066 | 0.048 | 0.035 | 0.023 | 0.016 |  |  |
| E5-06       | PM d-axis Inductance (mH/phase)  | mH                   | 3.83                                | 3.33  | 2.38  | 2.04  | 1.53  | 1.16  |  |  |
| E5-07       | PM q-axis Inductance (mH/phase)  | mH                   | 4.65                                | 4.50  | 3.15  | 2.86  | 2.27  | 1.54  |  |  |
| E5-09       | PM Back-EMF Vpeak (mV/(rad/s))   | mVs/rad              | 372.1                               | 421.3 | 410.9 | 436.1 | 428.8 | 433.3 |  |  |
| E5-24       | PM Back-EMF L-L Vrms (mV/rpm)    | mV/min <sup>-1</sup> | 0.0                                 | 0.0   | 0.0   | 0.0   | 0.0   | 0.0   |  |  |
| E1-04       | Maximum Output Frequency         | Hz                   | 57.5                                | 57.5  | 57.5  | 57.5  | 57.5  | 57.5  |  |  |
| E1-05       | Maximum Output Voltage           | V                    | 190.0                               | 190.0 | 190.0 | 190.0 | 190.0 | 190.0 |  |  |
| E1-06       | Base Frequency                   | Hz                   | 57.5                                | 57.5  | 57.5  | 57.5  | 57.5  | 57.5  |  |  |
| E1-09       | Minimum Output Frequency         | Hz                   | 2.9                                 | 2.9   | 2.9   | 2.9   | 2.9   | 2.9   |  |  |
| C5-17       | Motor Inertia                    | kgm <sup>2</sup>     | 0.064                               | 0.116 | 0.140 | 0.259 | 0.312 | 0.418 |  |  |
| L3-24<br>*J | Motor Accel Time @ Rated Torque  | s                    | 0.062                               | 0.091 | 0.092 | 0.125 | 0.122 | 0.135 |  |  |
| n5-02       | Motor Inertia Acceleration Time  | s                    | 0.062                               | 0.091 | 0.092 | 0.125 | 0.122 | 0.135 |  |  |
| n8-49       | Heavy Load Id Current            | %                    | -14.4                               | -17.9 | -15.9 | -17.9 | -20.1 | -13.7 |  |  |

\*1 The default setting changes when the setting for o2-04 [Drive Model Selection] changes.

## 1.22 Parameters Changed by PM Motor Code Selection

**Table 1.18 SSR1 Series Motor Code Setting for Specification of 400 V at 1150 min<sup>-1</sup> (r/min)**

| No.      | Name                             | Unit                 | Motor Code (setting value of E5-01) |        |        |        |        |       |       |       |
|----------|----------------------------------|----------------------|-------------------------------------|--------|--------|--------|--------|-------|-------|-------|
| E5-01    | PM Motor Code Selection          | -                    | 1432                                | 1433   | 1435   | 1436   | 1438   | 143A  | 143B  | 143D  |
|          | Voltage Class                    | V                    | 400                                 | 400    | 400    | 400    | 400    | 400   | 400   | 400   |
|          | Capacity                         | kW                   | 0.4                                 | 0.75   | 1.5    | 2.2    | 3.7    | 5.5   | 7.5   | 11    |
|          | Motor Rotation Speed             | min <sup>-1</sup>    | 1150                                | 1150   | 1150   | 1150   | 1150   | 1150  | 1150  | 1150  |
| E5-02    | PM Motor Rated Power             | kW                   | 0.4                                 | 0.75   | 1.5    | 2.2    | 3.7    | 5.5   | 7.5   | 11.0  |
| E5-03    | PM Motor Rated Current (FLA)     | A                    | 0.94                                | 1.51   | 3.00   | 4.43   | 7.08   | 10.10 | 13.33 | 19.9  |
| E5-04    | PM Motor Pole Count              | -                    | 6                                   | 6      | 6      | 6      | 6      | 6     | 6     | 6     |
| E5-05    | PM Motor Resistance (ohms/phase) | Ω                    | 19.320                              | 10.800 | 4.456  | 2.044  | 1.483  | 1.215 | 0.660 | 0.443 |
| E5-06    | PM d-axis Inductance (mH/phase)  | mH                   | 194.70                              | 129.20 | 76.88  | 48.60  | 37.58  | 44.54 | 26.36 | 19.10 |
| E5-07    | PM q-axis Inductance (mH/phase)  | mH                   | 252.84                              | 160.90 | 97.52  | 61.40  | 47.65  | 56.26 | 34.20 | 24.67 |
| E5-09    | PM Back-EMF Vpeak (mV/(rad/s))   | mVs/rad              | 640.9                               | 654.1  | 728.8  | 688.9  | 702.0  | 861.5 | 783.0 | 762.2 |
| E5-24    | PM Back-EMF L-L Vrms (mV/rpm)    | mV/min <sup>-1</sup> | 0.0                                 | 0.0    | 0.0    | 0.0    | 0.0    | 0.0   | 0.0   | 0.0   |
| E1-04    | Maximum Output Frequency         | Hz                   | 57.5                                | 57.5   | 57.5   | 57.5   | 57.5   | 57.5  | 57.5  | 57.5  |
| E1-05    | Maximum Output Voltage           | V                    | 380.0                               | 380.0  | 380.0  | 380.0  | 380.0  | 380.0 | 380.0 | 380.0 |
| E1-06    | Base Frequency                   | Hz                   | 57.5                                | 57.5   | 57.5   | 57.5   | 57.5   | 57.5  | 57.5  | 57.5  |
| E1-09    | Minimum Output Frequency         | Hz                   | 2.9                                 | 2.9    | 2.9    | 2.9    | 2.9    | 2.9   | 2.9   | 2.9   |
| C5-17    | Motor Inertia                    | kgm <sup>2</sup>     | 0.0017                              | 0.0023 | 0.0083 | 0.0136 | 0.0171 | 0.027 | 0.046 | 0.055 |
| L3-24 *1 | Motor Accel Time @ Rated Torque  | s                    | 0.062                               | 0.044  | 0.080  | 0.090  | 0.067  | 0.072 | 0.088 | 0.073 |
| n5-02    | Motor Inertia Acceleration Time  | s                    | 0.062                               | 0.044  | 0.080  | 0.090  | 0.067  | 0.072 | 0.088 | 0.073 |
| n8-49    | Heavy Load Id Current            | %                    | -8.8                                | -9.9   | -9.3   | -10.0  | -12.8  | -12.3 | -15.3 | -16.7 |

\*1 The default setting changes when the setting for o2-04 [Drive Model Selection] changes.

**Table 1.19 SSR1 Series Motor Code Setting for Specification of 400 V at 1150 min<sup>-1</sup> (r/min)**

| No.   | Name                             | Unit                 | Motor Code (setting value of E5-01) |       |       |       |       |       |
|-------|----------------------------------|----------------------|-------------------------------------|-------|-------|-------|-------|-------|
| E5-01 | PM Motor Code Selection          | -                    | 143E                                | 143F  | 1440  | 1442  | 1443  | 1444  |
|       | Voltage Class                    | V                    | 400                                 | 400   | 400   | 400   | 400   | 400   |
|       | Capacity                         | kW                   | 15                                  | 18    | 22    | 30    | 37    | 45    |
|       | Motor Rotation Speed             | min <sup>-1</sup>    | 1150                                | 1150  | 1150  | 1150  | 1150  | 1150  |
| E5-02 | PM Motor Rated Power             | kW                   | 15                                  | 18.50 | 22.00 | 30.00 | 37.00 | 45.00 |
| E5-03 | PM Motor Rated Current (FLA)     | A                    | 27.8                                | 31.8  | 37.2  | 52.1  | 64.8  | 76.6  |
| E5-04 | PM Motor Pole Count              | -                    | 6                                   | 6     | 6     | 6     | 6     | 6     |
| E5-05 | PM Motor Resistance (ohms/phase) | Ω                    | 0.331                               | 0.264 | 0.192 | 0.140 | 0.093 | 0.063 |
| E5-06 | PM d-axis Inductance (mH/phase)  | mH                   | 15.09                               | 13.32 | 9.52  | 8.16  | 6.13  | 4.63  |
| E5-07 | PM q-axis Inductance (mH/phase)  | mH                   | 18.56                               | 18.00 | 12.60 | 11.40 | 9.10  | 6.15  |
| E5-09 | PM Back-EMF Vpeak (mV/(rad/s))   | mVs/rad              | 749.6                               | 842.7 | 821.8 | 872.3 | 857.7 | 866.6 |
| E5-24 | PM Back-EMF L-L Vrms (mV/rpm)    | mV/min <sup>-1</sup> | 0.0                                 | 0.0   | 0.0   | 0.0   | 0.0   | 0.0   |

## 1.22 Parameters Changed by PM Motor Code Selection

| No.         | Name                            | Unit             | Motor Code (setting value of E5-01) |       |       |       |       |       |
|-------------|---------------------------------|------------------|-------------------------------------|-------|-------|-------|-------|-------|
|             |                                 |                  |                                     |       |       |       |       |       |
| E1-04       | Maximum Output Frequency        | Hz               | 57.5                                | 57.5  | 57.5  | 57.5  | 57.5  | 57.5  |
| E1-05       | Maximum Output Voltage          | V                | 380.0                               | 380.0 | 380.0 | 380.0 | 380.0 | 380.0 |
| E1-06       | Base Frequency                  | Hz               | 57.5                                | 57.5  | 57.5  | 57.5  | 57.5  | 57.5  |
| E1-09       | Minimum Output Frequency        | Hz               | 2.9                                 | 2.9   | 2.9   | 2.9   | 2.9   | 2.9   |
| C5-17       | Motor Inertia                   | kgm <sup>2</sup> | 0.064                               | 0.116 | 0.140 | 0.259 | 0.312 | 0.418 |
| L3-24<br>*I | Motor Accel Time @ Rated Torque | s                | 0.062                               | 0.091 | 0.092 | 0.125 | 0.122 | 0.135 |
| n5-02       | Motor Inertia Acceleration Time | s                | 0.062                               | 0.091 | 0.092 | 0.125 | 0.122 | 0.135 |
| n8-49       | Heavy Load Id Current           | %                | -14.9                               | -17.9 | -15.9 | -17.7 | -20.1 | -13.8 |

\*1 The default setting changes when the setting for o2-04 [Drive Model Selection] changes.

**Table 1.20 SSR1 Series Motor Code Setting for Specification of 400 V at 1150 min<sup>-1</sup> (r/min)**

| No.         | Name                                       | Unit                 | Motor Code (setting value of E5-01) |       |       |        |
|-------------|--|----------------------|-------------------------------------|-------|-------|--------|
|             |  |                      |                                     |       |       |        |
| E5-01       | PM Motor Code Selection                    | -                    | 1445                                | 1446  | 1447  | 1448   |
|             | Voltage Class                              | V                    | 400                                 | 400   | 400   | 400    |
|             | Capacity                                   | kW                   | 55                                  | 75    | 90    | 110    |
|             | Motor Rotation Speed                       | min <sup>-1</sup>    | 1150                                | 1150  | 1150  | 1150   |
| E5-02       | PM Motor Rated Power                       | kW                   | 55.00                               | 75.00 | 90.00 | 110.00 |
| E5-03       | PM Motor Rated Current (FLA)               | A                    | 92.0                                | 127.1 | 150.5 | 185.4  |
| E5-04       | PM Motor Pole Count                        | -                    | 6                                   | 6     | 6     | 6      |
| E5-05       | PM Motor Resistance (ohms/phase)           | Ω                    | 0.051                               | 0.033 | 0.027 | 0.015  |
| E5-06       | PM d-axis Inductance (mH/phase)            | mH                   | 3.96                                | 3.03  | 2.60  | 1.89   |
| E5-07       | PM q-axis Inductance (mH/phase)            | mH                   | 5.00                                | 5.14  | 3.28  | 2.33   |
| E5-09       | PM Back-EMF V <sub>peak</sub> (mV/(rad/s)) | mVs/rad              | 854.0                               | 823.1 | 853.4 | 829.2  |
| E5-24       | PM Back-EMF L-L V <sub>rms</sub> (mV/rpm)  | mV/min <sup>-1</sup> | 0.0                                 | 0.0   | 0.0   | 0.0    |
| E1-04       | Maximum Output Frequency                   | Hz                   | 57.5                                | 57.5  | 57.5  | 57.5   |
| E1-05       | Maximum Output Voltage                     | V                    | 380.0                               | 380.0 | 380.0 | 380.0  |
| E1-06       | Base Frequency                             | Hz                   | 57.5                                | 57.5  | 57.5  | 57.5   |
| E1-09       | Minimum Output Frequency                   | Hz                   | 2.9                                 | 2.9   | 2.9   | 2.9    |
| C5-17       | Motor Inertia                              | kgm <sup>2</sup>     | 0.56                                | 0.83  | 0.96  | 1.61   |
| L3-24<br>*I | Motor Accel Time @ Rated Torque            | s                    | 0.147                               | 0.161 | 0.154 | 0.212  |
| n5-02       | Motor Inertia Acceleration Time            | s                    | 0.147                               | 0.161 | 0.154 | 0.212  |
| n8-49       | Heavy Load Id Current                      | %                    | -12.5                               | -28.8 | -13.3 | -11.6  |

\*1 The default setting changes when the setting for o2-04 [Drive Model Selection] changes.

## 1.22 Parameters Changed by PM Motor Code Selection

### ◆ Yaskawa SST4 Series IPM Motors (Constant Torque)

Table 1.21 SST4 series motor code setting for specification of 200 V at 1750 min<sup>-1</sup> (r/min)

| No.         | Name                                     | Unit                 | Motor Code (setting value of E5-01) |        |        |        |        |       |       |       |
|-------------|--|----------------------|-------------------------------------|--------|--------|--------|--------|-------|-------|-------|
| E5-01       | PM Motor Code Selection                  | -                    | 2202                                | 2203   | 2205   | 2206   | 2208   | 220A  | 220B  | 220D  |
|             | Voltage Class                            | V                    | 200                                 | 200    | 200    | 200    | 200    | 200   | 200   | 200   |
|             | Capacity                                 | kW                   | 0.4                                 | 0.75   | 1.5    | 2.2    | 3.7    | 5.5   | 7.5   | 11    |
|             | Motor Rotation Speed                     | min <sup>-1</sup>    | 1750                                | 1750   | 1750   | 1750   | 1750   | 1750  | 1750  | 1750  |
| E5-02       | PM Motor Rated Power (kW)                | kW                   | 0.4                                 | 0.75   | 1.5    | 2.2    | 3.7    | 5.5   | 7.5   | 11.0  |
| E5-03       | PM Motor Rated Current (FLA)             | A                    | 1.77                                | 3.54   | 6.56   | 8.96   | 14.79  | 20.94 | 29.58 | 41.1  |
| E5-04       | PM Motor Pole Count                      | -                    | 6                                   | 6      | 6      | 6      | 6      | 6     | 6     | 6     |
| E5-05       | PM Motor Resistance (ohms/phase)         | Ω                    | 2.247                               | 1.132  | 0.774  | 0.479  | 0.242  | 0.275 | 0.161 | 0.111 |
| E5-06       | PM d-axis Inductance (mH/phase)          | mH                   | 22.32                               | 12.38  | 8.90   | 7.39   | 5.06   | 5.82  | 3.86  | 3.59  |
| E5-07       | PM q-axis Inductance (mH/phase)          | mH                   | 32.50                               | 15.72  | 11.96  | 9.63   | 6.42   | 6.74  | 4.66  | 4.32  |
| E5-09       | PM Motor Induced Voltage Constant 1 (Ke) | mVs/rad              | 215.2                               | 203.9  | 219.3  | 230.6  | 235.1  | 251.7 | 235.7 | 252.0 |
| E5-24       | PM Motor Induced Voltage Constant 2 (Ke) | mV/min <sup>-1</sup> | 0.0                                 | 0.0    | 0.0    | 0.0    | 0.0    | 0.0   | 0.0   | 0.0   |
| E1-04       | Maximum Output Frequency                 | Hz                   | 87.5                                | 87.5   | 87.5   | 87.5   | 87.5   | 87.5  | 87.5  | 87.5  |
| E1-05       | Maximum Output Voltage                   | V                    | 190.0                               | 190.0  | 190.0  | 190.0  | 190.0  | 190.0 | 190.0 | 190.0 |
| E1-06       | Base Frequency                           | Hz                   | 87.5                                | 87.5   | 87.5   | 87.5   | 87.5   | 87.5  | 87.5  | 87.5  |
| E1-09       | Minimum Output Frequency                 | Hz                   | 4.4                                 | 4.4    | 4.4    | 4.4    | 4.4    | 4.4   | 4.4   | 4.4   |
| C5-17       | Motor Inertia                            | kgm <sup>2</sup>     | 0.0016                              | 0.0022 | 0.0042 | 0.0081 | 0.0133 | 0.013 | 0.017 | 0.027 |
| L3-24<br>*J | Motor Accel Time for Inertia Cal         | s                    | 0.134                               | 0.099  | 0.094  | 0.124  | 0.121  | 0.081 | 0.075 | 0.082 |
| n5-02       | Motor Inertia Acceleration Time          | s                    | 0.134                               | 0.099  | 0.094  | 0.124  | 0.121  | 0.081 | 0.075 | 0.082 |
| n8-49       | d-Axis Cur for High Efficiency Cont      | %                    | -9.3                                | -6.4   | -10.0  | -9.9   | -9.7   | -8.4  | -11.5 | -13.1 |

\*1 The default setting changes when the setting for o2-04 [Drive Model Selection] changes.

Table 1.22 SST4 series motor code setting for specification of 200 V at 1750 min<sup>-1</sup> (r/min)

| No.   | Name                             | Unit              | Motor Code (setting value of E5-01) |       |       |       |       |       |       |       |
|-------|----------------------------------|-------------------|-------------------------------------|-------|-------|-------|-------|-------|-------|-------|
| E5-01 | PM Motor Code Selection          | -                 | 220E                                | 220F  | 2210  | 2212  | 2213  | 2214  | 2215  | 2216  |
|       | Voltage Class                    | V                 | 200                                 | 200   | 200   | 200   | 200   | 200   | 200   | 200   |
|       | Capacity                         | kW                | 15                                  | 18    | 22    | 30    | 37    | 45    | 55    | 75    |
|       | Motor Rotation Speed             | min <sup>-1</sup> | 1750                                | 1750  | 1750  | 1750  | 1750  | 1750  | 1750  | 1750  |
| E5-02 | PM Motor Rated Power             | kW                | 15                                  | 18.50 | 22.00 | 30.00 | 37.00 | 45.00 | 55.00 | 75.00 |
| E5-03 | PM Motor Rated Current (FLA)     | A                 | 54.2                                | 68.2  | 78.6  | 104.2 | 129.2 | 153.1 | 205.2 | 260.4 |
| E5-04 | PM Motor Pole Count              | -                 | 6                                   | 6     | 6     | 6     | 6     | 6     | 6     | 6     |
| E5-05 | PM Motor Resistance (ohms/phase) | Ω                 | 0.071                               | 0.049 | 0.040 | 0.030 | 0.020 | 0.013 | 0.009 | 0.006 |
| E5-06 | PM d-axis Inductance (mH/phase)  | mH                | 2.67                                | 1.98  | 1.69  | 1.31  | 0.88  | 0.77  | 0.55  | 0.40  |
| E5-07 | PM q-axis Inductance (mH/phase)  | mH                | 3.10                                | 2.41  | 2.12  | 1.61  | 1.14  | 1.04  | 0.69  | 0.50  |



## 1.22 Parameters Changed by PM Motor Code Selection

| No.         | Name                            | Unit                 | Motor Code (setting value of E5-01) |       |       |       |       |       |       |       |
|-------------|---------------------------------|----------------------|-------------------------------------|-------|-------|-------|-------|-------|-------|-------|
|             |                                 |                      |                                     |       |       |       |       |       |       |       |
| E5-09       | PM Back-EMF Vpeak (mV/(rad/s))  | mVs/rad              | 253.7                               | 244.6 | 256.3 | 283.1 | 266.3 | 260.0 | 261.5 | 259.3 |
| E5-24       | PM Back-EMF L-L Vrms (mV/rpm)   | mV/min <sup>-1</sup> | 0.0                                 | 0.0   | 0.0   | 0.0   | 0.0   | 0.0   | 0.0   | 0.0   |
| E1-04       | Maximum Output Frequency        | Hz                   | 87.5                                | 87.5  | 87.5  | 87.5  | 87.5  | 87.5  | 87.5  | 87.5  |
| E1-05       | Maximum Output Voltage          | V                    | 190.0                               | 190.0 | 190.0 | 190.0 | 190.0 | 190.0 | 190.0 | 190.0 |
| E1-06       | Base Frequency                  | Hz                   | 87.5                                | 87.5  | 87.5  | 87.5  | 87.5  | 87.5  | 87.5  | 87.5  |
| E1-09       | Minimum Output Frequency        | Hz                   | 4.4                                 | 4.4   | 4.4   | 4.4   | 4.4   | 4.4   | 4.4   | 4.4   |
| C5-17       | Motor Inertia                   | kgm <sup>2</sup>     | 0.044                               | 0.054 | 0.063 | 0.113 | 0.137 | 0.252 | 0.30  | 0.41  |
| L3-24<br>*J | Motor Accel Time @ Rated Torque | s                    | 0.099                               | 0.098 | 0.096 | 0.126 | 0.124 | 0.188 | 0.186 | 0.184 |
| n5-02       | Motor Inertia Acceleration Time | s                    | 0.099                               | 0.098 | 0.096 | 0.126 | 0.124 | 0.188 | 0.186 | 0.184 |
| n8-49       | Heavy Load Id Current           | %                    | -10.9                               | -14.3 | -15.1 | -11.3 | -14.1 | -18.8 | -11.4 | -12.2 |

\*1 The default setting changes when the setting for o2-04 [Drive Model Selection] changes.

**Table 1.23 SST4 Series Motor Code Setting for Specification of 400 V at 1750 min<sup>-1</sup> (r/min)**

| No.         | Name                             | Unit                 | Motor Code (setting value of E5-01) |        |        |        |        |       |       |       |
|-------------|----------------------------------|----------------------|-------------------------------------|--------|--------|--------|--------|-------|-------|-------|
|             |                                  |                      |                                     |        |        |        |        |       |       |       |
| E5-01       | PM Motor Code Selection          | -                    | 2232                                | 2233   | 2235   | 2236   | 2238   | 223A  | 223B  | 223D  |
|             | Voltage Class                    | V                    | 400                                 | 400    | 400    | 400    | 400    | 400   | 400   | 400   |
|             | Capacity                         | kW                   | 0.4                                 | 0.75   | 1.5    | 2.2    | 3.7    | 5.5   | 7.5   | 11    |
|             | Motor Rotation Speed             | min <sup>-1</sup>    | 1750                                | 1750   | 1750   | 1750   | 1750   | 1750  | 1750  | 1750  |
| E5-02       | PM Motor Rated Power             | kW                   | 0.4                                 | 0.75   | 1.5    | 2.2    | 3.7    | 5.5   | 7.5   | 11.0  |
| E5-03       | PM Motor Rated Current (FLA)     | A                    | 0.92                                | 1.77   | 3.33   | 4.48   | 7.50   | 10.42 | 14.27 | 20.5  |
| E5-04       | PM Motor Pole Count              | -                    | 6                                   | 6      | 6      | 6      | 6      | 6     | 6     | 6     |
| E5-05       | PM Motor Resistance (ohms/phase) | Ω                    | 8.935                               | 4.570  | 3.096  | 1.906  | 0.972  | 1.103 | 0.630 | 0.429 |
| E5-06       | PM d-axis Inductance (mH/phase)  | mH                   | 80.14                               | 48.04  | 35.60  | 30.31  | 20.03  | 23.41 | 14.86 | 14.34 |
| E5-07       | PM q-axis Inductance (mH/phase)  | mH                   | 110.76                              | 64.88  | 47.84  | 38.36  | 24.97  | 28.70 | 17.25 | 17.25 |
| E5-09       | PM Back-EMF Vpeak (mV/(rad/s))   | mVs/rad              | 416.5                               | 399.4  | 438.5  | 475.5  | 463.7  | 485.8 | 470.4 | 513.4 |
| E5-24       | PM Back-EMF L-L Vrms (mV/rpm)    | mV/min <sup>-1</sup> | 0.0                                 | 0.0    | 0.0    | 0.0    | 0.0    | 0.0   | 0.0   | 0.0   |
| E1-04       | Maximum Output Frequency         | Hz                   | 87.5                                | 87.5   | 87.5   | 87.5   | 87.5   | 87.5  | 87.5  | 87.5  |
| E1-05       | Maximum Output Voltage           | V                    | 380.0                               | 380.0  | 380.0  | 380.0  | 380.0  | 380.0 | 380.0 | 380.0 |
| E1-06       | Base Frequency                   | Hz                   | 87.5                                | 87.5   | 87.5   | 87.5   | 87.5   | 87.5  | 87.5  | 87.5  |
| E1-09       | Minimum Output Frequency         | Hz                   | 4.4                                 | 4.4    | 4.4    | 4.4    | 4.4    | 4.4   | 4.4   | 4.4   |
| C5-17       | Motor Inertia                    | kgm <sup>2</sup>     | 0.0016                              | 0.0022 | 0.0042 | 0.0081 | 0.0133 | 0.013 | 0.017 | 0.027 |
| L3-24<br>*J | Motor Accel Time @ Rated Torque  | s                    | 0.134                               | 0.099  | 0.094  | 0.124  | 0.121  | 0.081 | 0.075 | 0.082 |
| n5-02       | Motor Inertia Acceleration Time  | s                    | 0.134                               | 0.099  | 0.094  | 0.124  | 0.121  | 0.081 | 0.075 | 0.082 |
| n8-49       | Heavy Load Id Current            | %                    | -7.5                                | -8.5   | -9.8   | -8.2   | -9.1   | -13.1 | -9.2  | -12.4 |

\*1 The default setting changes when the setting for o2-04 [Drive Model Selection] changes.

## 1.22 Parameters Changed by PM Motor Code Selection

**Table 1.24 SST4 Series Motor Code Setting for Specification of 400 V at 1750 min<sup>-1</sup> (r/min)**

| No.      | Name                             | Unit                 | Motor Code (setting value of E5-01) |       |       |       |       |       |       |       |
|----------|----------------------------------|----------------------|-------------------------------------|-------|-------|-------|-------|-------|-------|-------|
| E5-01    | PM Motor Code Selection          | -                    | 223E                                | 223F  | 2240  | 2242  | 2243  | 2244  | 2245  | 2246  |
|          | Voltage Class                    | V                    | 400                                 | 400   | 400   | 400   | 400   | 400   | 400   | 400   |
|          | Capacity                         | kW                   | 15                                  | 18    | 22    | 30    | 37    | 45    | 55    | 75    |
|          | Motor Rotation Speed             | min <sup>-1</sup>    | 1750                                | 1750  | 1750  | 1750  | 1750  | 1750  | 1750  | 1750  |
| E5-02    | PM Motor Rated Power             | kW                   | 15                                  | 18.50 | 22.00 | 30.00 | 37.00 | 45.00 | 55.00 | 75.00 |
| E5-03    | PM Motor Rated Current (FLA)     | A                    | 26.4                                | 34.2  | 38.8  | 52.2  | 65.4  | 77.6  | 99.3  | 130.2 |
| E5-04    | PM Motor Pole Count              | -                    | 6                                   | 6     | 6     | 6     | 6     | 6     | 6     | 6     |
| E5-05    | PM Motor Resistance (ohms/phase) | Ω                    | 0.275                               | 0.196 | 0.160 | 0.120 | 0.077 | 0.052 | 0.036 | 0.023 |
| E5-06    | PM d-axis Inductance (mH/phase)  | mH                   | 9.99                                | 7.92  | 6.82  | 5.24  | 3.57  | 2.98  | 1.59  | 1.59  |
| E5-07    | PM q-axis Inductance (mH/phase)  | mH                   | 12.37                               | 9.64  | 8.51  | 6.44  | 4.65  | 3.75  | 2.78  | 1.97  |
| E5-09    | PM Back-EMF Vpeak (mV/(rad/s))   | mVs/rad              | 505.3                               | 489.2 | 509.5 | 566.2 | 531.6 | 530.6 | 515.2 | 515.2 |
| E5-24    | PM Back-EMF L-L Vrms (mV/rpm)    | mV/min <sup>-1</sup> | 0.0                                 | 0.0   | 0.0   | 0.0   | 0.0   | 0.0   | 0.0   | 0.0   |
| E1-04    | Maximum Output Frequency         | Hz                   | 87.5                                | 87.5  | 87.5  | 87.5  | 87.5  | 87.5  | 87.5  | 87.5  |
| E1-05    | Maximum Output Voltage           | V                    | 380.0                               | 380.0 | 380.0 | 380.0 | 380.0 | 380.0 | 380.0 | 380.0 |
| E1-06    | Base Frequency                   | Hz                   | 87.5                                | 87.5  | 87.5  | 87.5  | 87.5  | 87.5  | 87.5  | 87.5  |
| E1-09    | Minimum Output Frequency         | Hz                   | 4.4                                 | 4.4   | 4.4   | 4.4   | 4.4   | 4.4   | 4.4   | 4.4   |
| C5-17    | Motor Inertia                    | kgm <sup>2</sup>     | 0.044                               | 0.054 | 0.063 | 0.113 | 0.137 | 0.252 | 0.30  | 0.41  |
| L3-24 *1 | Motor Accel Time @ Rated Torque  | s                    | 0.099                               | 0.098 | 0.096 | 0.126 | 0.124 | 0.188 | 0.186 | 0.184 |
| n5-02    | Motor Inertia Acceleration Time  | s                    | 0.099                               | 0.098 | 0.096 | 0.126 | 0.124 | 0.188 | 0.186 | 0.184 |
| n8-49    | Heavy Load Id Current            | %                    | -15.1                               | -14.3 | -15.3 | -11.3 | -14.5 | -13.2 | -22.6 | -11.9 |

\*1 The default setting changes when the setting for o2-04 [Drive Model Selection] changes.

**Table 1.25 SST4 Series Motor Code Setting for Specification of 400 V at 1750 min<sup>-1</sup> (r/min)**

| No.   | Name                             | Unit                 | Motor Code (setting value of E5-01) |        |        |        |        |        |        |  |
|-------|----------------------------------|----------------------|-------------------------------------|--------|--------|--------|--------|--------|--------|--|
| E5-01 | PM Motor Code Selection          | -                    | 2247                                | 2248   | 2249   | 224A   | 224C   | 224D   | 224E   |  |
|       | Voltage Class                    | V                    | 400                                 | 400    | 400    | 400    | 400    | 400    | 400    |  |
|       | Capacity                         | kW                   | 90                                  | 110    | 132    | 160    | 200    | 220    | 300    |  |
|       | Motor Rotation Speed             | min <sup>-1</sup>    | 1750                                | 1750   | 1750   | 1750   | 1750   | 1750   | 1750   |  |
| E5-02 | PM Motor Rated Power             | kW                   | 90.00                               | 110.00 | 132.00 | 160.00 | 200.00 | 250.00 | 300.00 |  |
| E5-03 | PM Motor Rated Current (FLA)     | A                    | 153.1                               | 184.4  | 229.2  | 269.8  | 346.9  | 421.9  | 520.8  |  |
| E5-04 | PM Motor Pole Count              | -                    | 6                                   | 6      | 6      | 6      | 6      | 6      | 6      |  |
| E5-05 | PM Motor Resistance (ohms/phase) | Ω                    | 0.019                               | 0.017  | 0.012  | 0.008  | 0.005  | 0.004  | 0.002  |  |
| E5-06 | PM d-axis Inductance (mH/phase)  | mH                   | 1.51                                | 1.43   | 1.13   | 0.96   | 0.65   | 0.67   | 0.40   |  |
| E5-07 | PM q-axis Inductance (mH/phase)  | mH                   | 1.76                                | 1.92   | 1.54   | 1.26   | 0.88   | 0.74   | 0.52   |  |
| E5-09 | PM Back-EMF Vpeak (mV/(rad/s))   | mVs/rad              | 538.3                               | 590.9  | 548.2  | 603.9  | 556.8  | 593.1  | 495.4  |  |
| E5-24 | PM Back-EMF L-L Vrms (mV/rpm)    | mV/min <sup>-1</sup> | 0.0                                 | 0.0    | 0.0    | 0.0    | 0.0    | 0.0    | 0.0    |  |

## 1.22 Parameters Changed by PM Motor Code Selection

| No.         | Name                            | Unit             | Motor Code (setting value of E5-01) |       |       |       |       |       |       |
|-------------|---------------------------------|------------------|-------------------------------------|-------|-------|-------|-------|-------|-------|
|             |                                 |                  |                                     |       |       |       |       |       |       |
| E1-04       | Maximum Output Frequency        | Hz               | 87.5                                | 87.5  | 87.5  | 87.5  | 87.5  | 87.5  | 87.5  |
| E1-05       | Maximum Output Voltage          | V                | 380.0                               | 380.0 | 380.0 | 380.0 | 380.0 | 380.0 | 380.0 |
| E1-06       | Base Frequency                  | Hz               | 87.5                                | 87.5  | 87.5  | 87.5  | 87.5  | 87.5  | 87.5  |
| E1-09       | Minimum Output Frequency        | Hz               | 4.4                                 | 4.4   | 4.4   | 4.4   | 4.4   | 4.4   | 4.4   |
| C5-17       | Motor Inertia                   | kgm <sup>2</sup> | 0.55                                | 0.82  | 0.96  | 1.60  | 1.95  | 2.82  | 3.70  |
| L3-24<br>*I | Motor Accel Time @ Rated Torque | s                | 0.205                               | 0.250 | 0.244 | 0.336 | 0.327 | 0.379 | 0.414 |
| n5-02       | Motor Inertia Acceleration Time | s                | 0.205                               | 0.250 | 0.244 | 0.336 | 0.327 | 0.379 | 0.414 |
| n8-49       | Heavy Load Id Current           | %                | -8.6                                | -14.8 | -17.5 | -12.5 | -14.7 | -5.1  | -16.3 |

\*1 The default setting changes when the setting for o2-04 [Drive Model Selection] changes.

**Table 1.26 SST4 Series Motor Code Setting for Specification of 200 V at 1450 min<sup>-1</sup> (r/min)**

| No.         | Name                             | Unit                 | Motor Code (setting value of E5-01) |        |        |        |        |       |       |       |
|-------------|----------------------------------|----------------------|-------------------------------------|--------|--------|--------|--------|-------|-------|-------|
|             |                                  |                      |                                     |        |        |        |        |       |       |       |
| E5-01       | PM Motor Code Selection          | -                    | 2302                                | 2303   | 2305   | 2306   | 2308   | 230A  | 230B  | 230D  |
|             | Voltage Class                    | V                    | 200                                 | 200    | 200    | 200    | 200    | 200   | 200   | 200   |
|             | Capacity                         | kW                   | 0.4                                 | 0.75   | 1.5    | 2.2    | 3.7    | 5.5   | 7.5   | 11    |
|             | Motor Rotation Speed             | min <sup>-1</sup>    | 1450                                | 1450   | 1450   | 1450   | 1450   | 1450  | 1450  | 1450  |
| E5-02       | PM Motor Rated Power             | kW                   | 0.4                                 | 0.75   | 1.5    | 2.2    | 3.7    | 5.5   | 7.5   | 11.0  |
| E5-03       | PM Motor Rated Current (FLA)     | A                    | 1.77                                | 3.33   | 5.94   | 9.48   | 14.17  | 20.42 | 27.92 | 39.6  |
| E5-04       | PM Motor Pole Count              | -                    | 6                                   | 6      | 6      | 6      | 6      | 6     | 6     | 6     |
| E5-05       | PM Motor Resistance (ohms/phase) | Ω                    | 3.154                               | 1.835  | 0.681  | 0.308  | 0.405  | 0.278 | 0.180 | 0.098 |
| E5-06       | PM d-axis Inductance (mH/phase)  | mH                   | 28.46                               | 19.46  | 10.00  | 6.88   | 8.15   | 5.77  | 6.32  | 3.34  |
| E5-07       | PM q-axis Inductance (mH/phase)  | mH                   | 39.29                               | 25.89  | 15.20  | 9.25   | 10.76  | 8.60  | 8.80  | 4.61  |
| E5-09       | PM Back-EMF Vpeak (mV/(rad/s))   | mVs/rad              | 268.8                               | 256.9  | 271.9  | 260.2  | 286.8  | 314.9 | 300.8 | 292.3 |
| E5-24       | PM Back-EMF L-L Vrms (mV/rpm)    | mV/min <sup>-1</sup> | 0.0                                 | 0.0    | 0.0    | 0.0    | 0.0    | 0.0   | 0.0   | 0.0   |
| E1-04       | Maximum Output Frequency         | Hz                   | 72.5                                | 72.5   | 72.5   | 72.5   | 72.5   | 72.5  | 72.5  | 72.5  |
| E1-05       | Maximum Output Voltage           | V                    | 190.0                               | 190.0  | 190.0  | 190.0  | 190.0  | 190.0 | 190.0 | 190.0 |
| E1-06       | Base Frequency                   | Hz                   | 72.5                                | 72.5   | 72.5   | 72.5   | 72.5   | 72.5  | 72.5  | 72.5  |
| E1-09       | Minimum Output Frequency         | Hz                   | 3.6                                 | 3.6    | 3.6    | 3.6    | 3.6    | 3.6   | 3.6   | 3.6   |
| C5-17       | Motor Inertia                    | kgm <sup>2</sup>     | 0.0016                              | 0.0022 | 0.0081 | 0.0133 | 0.0133 | 0.017 | 0.027 | 0.044 |
| L3-24<br>*I | Motor Accel Time @ Rated Torque  | s                    | 0.092                               | 0.068  | 0.125  | 0.139  | 0.083  | 0.070 | 0.082 | 0.092 |
| n5-02       | Motor Inertia Acceleration Time  | s                    | 0.092                               | 0.068  | 0.125  | 0.139  | 0.083  | 0.070 | 0.082 | 0.092 |
| n8-49       | Heavy Load Id Current            | %                    | -7.5                                | -9.4   | -13.9  | -10.0  | -15.0  | -17.9 | -22.7 | -20.5 |

\*1 The default setting changes when the setting for o2-04 [Drive Model Selection] changes.

## 1.22 Parameters Changed by PM Motor Code Selection

**Table 1.27 SST4 Series Motor Code Setting for Specification of 200 V at 1450 min<sup>-1</sup> (r/min)**

| No.      | Name                             | Unit                 | Motor Code (setting value of E5-01) |       |       |       |       |       |       |       |
|----------|----------------------------------|----------------------|-------------------------------------|-------|-------|-------|-------|-------|-------|-------|
| E5-01    | PM Motor Code Selection          | -                    | 230E                                | 230F  | 2310  | 2312  | 2313  | 2314  | 2315  | 2316  |
|          | Voltage Class                    | V                    | 200                                 | 200   | 200   | 200   | 200   | 200   | 200   | 200   |
|          | Capacity                         | kW                   | 15                                  | 18    | 22    | 30    | 37    | 45    | 55    | 75    |
|          | Motor Rotation Speed             | min <sup>-1</sup>    | 1450                                | 1450  | 1450  | 1450  | 1450  | 1450  | 1450  | 1450  |
| E5-02    | PM Motor Rated Power             | kW                   | 15.0                                | 18.50 | 22.00 | 30.00 | 37.00 | 45.00 | 55.00 | 75.00 |
| E5-03    | PM Motor Rated Current (FLA)     | A                    | 54.2                                | 68.3  | 75.2  | 102.0 | 131.3 | 160.4 | 191.7 | 257.3 |
| E5-04    | PM Motor Pole Count              | -                    | 6                                   | 6     | 6     | 6     | 6     | 6     | 6     | 6     |
| E5-05    | PM Motor Resistance (ohms/phase) | Ω                    | 0.073                               | 0.055 | 0.048 | 0.034 | 0.023 | 0.016 | 0.012 | 0.007 |
| E5-06    | PM d-axis Inductance (mH/phase)  | mH                   | 2.94                                | 2.23  | 2.08  | 1.67  | 1.39  | 0.94  | 0.82  | 0.56  |
| E5-07    | PM q-axis Inductance (mH/phase)  | mH                   | 3.65                                | 2.85  | 2.66  | 2.04  | 1.73  | 1.22  | 1.06  | 0.76  |
| E5-09    | PM Back-EMF Vpeak (mV/(rad/s))   | mVs/rad              | 305.1                               | 297.6 | 355.8 | 355.4 | 324.0 | 302.4 | 337.2 | 323.4 |
| E5-24    | PM Back-EMF L-L Vrms (mV/rpm)    | mV/min <sup>-1</sup> | 0.0                                 | 0.0   | 0.0   | 0.0   | 0.0   | 0.0   | 0.0   | 0.0   |
| E1-04    | Maximum Output Frequency         | Hz                   | 72.5                                | 72.5  | 72.5  | 72.5  | 72.5  | 72.5  | 72.5  | 72.5  |
| E1-05    | Maximum Output Voltage           | V                    | 190.0                               | 190.0 | 190.0 | 190.0 | 190.0 | 190.0 | 190.0 | 190.0 |
| E1-06    | Base Frequency                   | Hz                   | 72.5                                | 72.5  | 72.5  | 72.5  | 72.5  | 72.5  | 72.5  | 72.5  |
| E1-09    | Minimum Output Frequency         | Hz                   | 3.6                                 | 3.6   | 3.6   | 3.6   | 3.6   | 3.6   | 3.6   | 3.6   |
| C5-17    | Motor Inertia                    | kgm <sup>2</sup>     | 0.054                               | 0.063 | 0.113 | 0.137 | 0.252 | 0.304 | 0.41  | 0.55  |
| L3-24 *1 | Motor Accel Time @ Rated Torque  | s                    | 0.083                               | 0.079 | 0.118 | 0.105 | 0.157 | 0.156 | 0.172 | 0.169 |
| n5-02    | Motor Inertia Acceleration Time  | s                    | 0.083                               | 0.079 | 0.118 | 0.105 | 0.157 | 0.156 | 0.172 | 0.169 |
| n8-49    | Heavy Load Id Current            | %                    | -14.6                               | -16.4 | -11.8 | -10.5 | -14.5 | -17.4 | -13.8 | -17.5 |

\*1 The default setting changes when the setting for o2-04 [Drive Model Selection] changes.

**Table 1.28 SST4 Series Motor Code Setting for Specification of 400 V at 1450 min<sup>-1</sup> (r/min)**

| No.   | Name                             | Unit              | Motor Code (setting value of E5-01) |        |       |       |       |       |       |       |
|-------|----------------------------------|-------------------|-------------------------------------|--------|-------|-------|-------|-------|-------|-------|
| E5-01 | PM Motor Code Selection          | -                 | 2332                                | 2333   | 2335  | 2336  | 2338  | 233A  | 233B  | 233D  |
|       | Voltage Class                    | V                 | 400                                 | 400    | 400   | 400   | 400   | 400   | 400   | 400   |
|       | Capacity                         | kW                | 0.4                                 | 0.75   | 1.5   | 2.2   | 3.7   | 5.5   | 7.5   | 11    |
|       | Motor Rotation Speed             | min <sup>-1</sup> | 1450                                | 1450   | 1450  | 1450  | 1450  | 1450  | 1450  | 1450  |
| E5-02 | PM Motor Rated Power             | kW                | 0.4                                 | 0.75   | 1.5   | 2.2   | 3.7   | 5.5   | 7.5   | 11.0  |
| E5-03 | PM Motor Rated Current (FLA)     | A                 | 0.91                                | 1.67   | 3.02  | 4.74  | 7.08  | 10.21 | 13.96 | 20.5  |
| E5-04 | PM Motor Pole Count              | -                 | 6                                   | 6      | 6     | 6     | 6     | 6     | 6     | 6     |
| E5-05 | PM Motor Resistance (ohms/phase) | Ω                 | 12.616                              | 7.340  | 2.724 | 1.232 | 1.509 | 1.112 | 0.720 | 0.393 |
| E5-06 | PM d-axis Inductance (mH/phase)  | mH                | 113.84                              | 77.84  | 40.00 | 27.52 | 31.73 | 23.09 | 25.28 | 13.36 |
| E5-07 | PM q-axis Inductance (mH/phase)  | mH                | 157.16                              | 103.56 | 60.80 | 37.00 | 40.88 | 34.39 | 35.20 | 18.44 |
| E5-09 | PM Back-EMF Vpeak (mV/(rad/s))   | mVs/rad           | 490.8                               | 513.8  | 543.7 | 520.3 | 580.8 | 602.7 | 601.5 | 584.6 |

## 1.22 Parameters Changed by PM Motor Code Selection

| No.         | Name                            | Unit                 | Motor Code (setting value of E5-01) |        |        |        |        |       |       |       |
|-------------|---------------------------------|----------------------|-------------------------------------|--------|--------|--------|--------|-------|-------|-------|
|             |                                 |                      |                                     |        |        |        |        |       |       |       |
| E5-24       | PM Back-EMF L-L Vrms (mV/rpm)   | mV/min <sup>-1</sup> | 0.0                                 | 0.0    | 0.0    | 0.0    | 0.0    | 0.0   | 0.0   | 0.0   |
| E1-04       | Maximum Output Frequency        | Hz                   | 72.5                                | 72.5   | 72.5   | 72.5   | 72.5   | 72.5  | 72.5  | 72.5  |
| E1-05       | Maximum Output Voltage          | V                    | 380.0                               | 380.0  | 380.0  | 380.0  | 380.0  | 380.0 | 380.0 | 380.0 |
| E1-06       | Base Frequency                  | Hz                   | 72.5                                | 72.5   | 72.5   | 72.5   | 72.5   | 72.5  | 72.5  | 72.5  |
| E1-09       | Minimum Output Frequency        | Hz                   | 3.6                                 | 3.6    | 3.6    | 3.6    | 3.6    | 3.6   | 3.6   | 3.6   |
| C5-17       | Motor Inertia                   | kgm <sup>2</sup>     | 0.0016                              | 0.0022 | 0.0081 | 0.0133 | 0.0133 | 0.017 | 0.027 | 0.044 |
| L3-24<br>*J | Motor Accel Time @ Rated Torque | s                    | 0.092                               | 0.068  | 0.125  | 0.139  | 0.083  | 0.070 | 0.082 | 0.092 |
| n5-02       | Motor Inertia Acceleration Time | s                    | 0.092                               | 0.068  | 0.125  | 0.139  | 0.083  | 0.070 | 0.082 | 0.092 |
| n8-49       | Heavy Load Id Current           | %                    | -9.5                                | -9.4   | -13.7  | -10.0  | -12.9  | -19.9 | -22.8 | -19.8 |

\*1 The default setting changes when the setting for o2-04 [Drive Model Selection] changes.

**Table 1.29 SST4 Series Motor Code Setting for Specification of 400 V at 1450 min<sup>-1</sup> (r/min)**

| No.         | Name                             | Unit                 | Motor Code (setting value of E5-01) |       |       |       |       |       |       |       |
|-------------|----------------------------------|----------------------|-------------------------------------|-------|-------|-------|-------|-------|-------|-------|
|             |                                  |                      |                                     |       |       |       |       |       |       |       |
| E5-01       | PM Motor Code Selection          | -                    | 233E                                | 233F  | 2340  | 2342  | 2343  | 2344  | 2345  | 2346  |
|             | Voltage Class                    | V                    | 400                                 | 400   | 400   | 400   | 400   | 400   | 400   | 400   |
|             | Capacity                         | kW                   | 15                                  | 18    | 22    | 30    | 37    | 45    | 55    | 75    |
|             | Motor Rotation Speed             | min <sup>-1</sup>    | 1450                                | 1450  | 1450  | 1450  | 1450  | 1450  | 1450  | 1450  |
| E5-02       | PM Motor Rated Power             | kW                   | 15                                  | 18.50 | 22.00 | 30.00 | 37.00 | 45.00 | 55.00 | 75.00 |
| E5-03       | PM Motor Rated Current (FLA)     | A                    | 27.1                                | 34.2  | 37.6  | 50.9  | 65.4  | 80.2  | 96.1  | 129.2 |
| E5-04       | PM Motor Pole Count              | -                    | 6                                   | 6     | 6     | 6     | 6     | 6     | 6     | 6     |
| E5-05       | PM Motor Resistance (ohms/phase) | Ω                    | 0.291                               | 0.220 | 0.192 | 0.136 | 0.091 | 0.064 | 0.048 | 0.028 |
| E5-06       | PM d-axis Inductance (mH/phase)  | mH                   | 11.77                               | 8.94  | 8.32  | 6.68  | 5.30  | 3.76  | 3.09  | 2.24  |
| E5-07       | PM q-axis Inductance (mH/phase)  | mH                   | 14.60                               | 11.40 | 10.64 | 8.16  | 6.80  | 4.88  | 4.75  | 3.03  |
| E5-09       | PM Back-EMF Vpeak (mV/(rad/s))   | mVs/rad              | 610.3                               | 595.2 | 711.6 | 710.8 | 652.7 | 604.8 | 669.1 | 646.8 |
| E5-24       | PM Back-EMF L-L Vrms (mV/rpm)    | mV/min <sup>-1</sup> | 0.0                                 | 0.0   | 0.0   | 0.0   | 0.0   | 0.0   | 0.0   | 0.0   |
| E1-04       | Maximum Output Frequency         | Hz                   | 72.5                                | 72.5  | 72.5  | 72.5  | 72.5  | 72.5  | 72.5  | 72.5  |
| E1-05       | Maximum Output Voltage           | V                    | 380.0                               | 380.0 | 380.0 | 380.0 | 380.0 | 380.0 | 380.0 | 380.0 |
| E1-06       | Base Frequency                   | Hz                   | 72.5                                | 72.5  | 72.5  | 72.5  | 72.5  | 72.5  | 72.5  | 72.5  |
| E1-09       | Minimum Output Frequency         | Hz                   | 3.6                                 | 3.6   | 3.6   | 3.6   | 3.6   | 3.6   | 3.6   | 3.6   |
| C5-17       | Motor Inertia                    | kgm <sup>2</sup>     | 0.054                               | 0.063 | 0.113 | 0.137 | 0.252 | 0.304 | 0.41  | 0.55  |
| L3-24<br>*J | Motor Accel Time @ Rated Torque  | s                    | 0.083                               | 0.079 | 0.118 | 0.105 | 0.157 | 0.156 | 0.172 | 0.169 |
| n5-02       | Motor Inertia Acceleration Time  | s                    | 0.083                               | 0.079 | 0.118 | 0.105 | 0.157 | 0.156 | 0.172 | 0.169 |
| n8-49       | Heavy Load Id Current            | %                    | -14.5                               | -16.1 | -11.8 | -10.5 | -15.6 | -17.4 | -21.7 | -17.3 |

\*1 The default setting changes when the setting for o2-04 [Drive Model Selection] changes.

## 1.22 Parameters Changed by PM Motor Code Selection

**Table 1.30 SST4 Series Motor Code Setting for Specification of 400 V at 1450 min<sup>-1</sup> (r/min)**

| No.      | Name                             | Unit                 | Motor Code (setting value of E5-01) |        |        |        |        |        |
|----------|----------------------------------|----------------------|-------------------------------------|--------|--------|--------|--------|--------|
| E5-01    | PM Motor Code Selection          | -                    | 2347                                | 2348   | 2349   | 234A   | 234C   | 234D   |
|          | Voltage Class                    | V                    | 400                                 | 400    | 400    | 400    | 400    | 400    |
|          | Capacity                         | kW                   | 90                                  | 110    | 132    | 160    | 200    | 250    |
|          | Motor Rotation Speed             | min <sup>-1</sup>    | 1450                                | 1450   | 1450   | 1450   | 1450   | 1450   |
| E5-02    | PM Motor Rated Power             | kW                   | 90.00                               | 110.00 | 132.00 | 160.00 | 200.00 | 250.00 |
| E5-03    | PM Motor Rated Current (FLA)     | A                    | 153.1                               | 191.7  | 226.0  | 268.8  | 331.3  | 422.9  |
| E5-04    | PM Motor Pole Count              | -                    | 6                                   | 6      | 6      | 6      | 6      | 6      |
| E5-05    | PM Motor Resistance (ohms/phase) | Ω                    | 0.024                               | 0.015  | 0.011  | 0.007  | 0.006  | 0.003  |
| E5-06    | PM d-axis Inductance (mH/phase)  | mH                   | 2.20                                | 1.34   | 1.23   | 0.92   | 0.84   | 0.61   |
| E5-07    | PM q-axis Inductance (mH/phase)  | mH                   | 3.23                                | 2.16   | 1.67   | 1.30   | 1.25   | 0.89   |
| E5-09    | PM Back-EMF Vpeak (mV/(rad/s))   | mVs/rad              | 708.0                               | 637.8  | 677.0  | 661.7  | 687.1  | 655.9  |
| E5-24    | PM Back-EMF L-L Vrms (mV/rpm)    | mV/min <sup>-1</sup> | 0.0                                 | 0.0    | 0.0    | 0.0    | 0      | 0.0    |
| E1-04    | Maximum Output Frequency         | Hz                   | 72.5                                | 72.5   | 72.5   | 72.5   | 72.5   | 72.5   |
| E1-05    | Maximum Output Voltage           | V                    | 380.0                               | 380.0  | 380.0  | 380.0  | 380.0  | 380.0  |
| E1-06    | Base Frequency                   | Hz                   | 72.5                                | 72.5   | 72.5   | 72.5   | 72.5   | 72.5   |
| E1-09    | Minimum Output Frequency         | Hz                   | 3.6                                 | 3.6    | 3.6    | 3.6    | 3.6    | 3.6    |
| C5-17    | Motor Inertia                    | kgm <sup>2</sup>     | 0.82                                | 0.96   | 1.60   | 1.95   | 2.82   | 3.70   |
| L3-24 *I | Motor Accel Time @ Rated Torque  | s                    | 0.210                               | 0.201  | 0.279  | 0.281  | 0.325  | 0.341  |
| n5-02    | Motor Inertia Acceleration Time  | s                    | 0.210                               | 0.201  | 0.279  | 0.281  | 0.325  | 0.341  |
| n8-49    | Heavy Load Id Current            | %                    | -19.6                               | -24.1  | -15.1  | -17.0  | -19.8  | -19.3  |

\*1 The default setting changes when the setting for o2-04 [Drive Model Selection] changes.

**Table 1.31 SST4 Series Motor Code Setting for Specification of 200 V at 1150 min<sup>-1</sup> (r/min)**

| No.   | Name                             | Unit              | Motor Code (setting value of E5-01) |       |       |       |       |       |       |       |
|-------|----------------------------------|-------------------|-------------------------------------|-------|-------|-------|-------|-------|-------|-------|
| E5-01 | PM Motor Code Selection          | -                 | 2402                                | 2403  | 2405  | 2406  | 2408  | 240A  | 240B  | 240D  |
|       | Voltage Class                    | V                 | 200                                 | 200   | 200   | 200   | 200   | 200   | 200   | 200   |
|       | Capacity                         | kW                | 0.4                                 | 0.75  | 1.5   | 2.2   | 3.7   | 5.5   | 7.5   | 11    |
|       | Motor Rotation Speed             | min <sup>-1</sup> | 1150                                | 1150  | 1150  | 1150  | 1150  | 1150  | 1150  | 1150  |
| E5-02 | PM Motor Rated Power             | kW                | 0.4                                 | 0.75  | 1.5   | 2.2   | 3.7   | 5.5   | 7.5   | 11.0  |
| E5-03 | PM Motor Rated Current (FLA)     | A                 | 1.77                                | 3.44  | 5.94  | 9.17  | 14.79 | 20.21 | 27.40 | 39.0  |
| E5-04 | PM Motor Pole Count              | -                 | 6                                   | 6     | 6     | 6     | 6     | 6     | 6     | 6     |
| E5-05 | PM Motor Resistance (ohms/phase) | Ω                 | 2.680                               | 1.520 | 1.071 | 0.542 | 0.362 | 0.295 | 0.162 | 0.115 |
| E5-06 | PM d-axis Inductance (mH/phase)  | mH                | 30.55                               | 15.29 | 17.48 | 11.98 | 8.60  | 9.54  | 5.31  | 4.44  |
| E5-07 | PM q-axis Inductance (mH/phase)  | mH                | 42.71                               | 24.28 | 22.51 | 15.51 | 10.69 | 13.84 | 8.26  | 5.68  |
| E5-09 | PM Back-EMF Vpeak (mV/(rad/s))   | mVs/rad           | 313.1                               | 313.1 | 345.3 | 342.9 | 363.8 | 384.3 | 379.9 | 370.2 |

## 1.22 Parameters Changed by PM Motor Code Selection

| No.         | Name                            | Unit                 | Motor Code (setting value of E5-01) |        |        |        |        |       |       |       |
|-------------|---------------------------------|----------------------|-------------------------------------|--------|--------|--------|--------|-------|-------|-------|
|             |                                 |                      |                                     |        |        |        |        |       |       |       |
| E5-24       | PM Back-EMF L-L Vrms (mV/rpm)   | mV/min <sup>-1</sup> | 0.0                                 | 0.0    | 0.0    | 0.0    | 0.0    | 0.0   | 0.0   | 0.0   |
| E1-04       | Maximum Output Frequency        | Hz                   | 57.5                                | 57.5   | 57.5   | 57.5   | 57.5   | 57.5  | 57.5  | 57.5  |
| E1-05       | Maximum Output Voltage          | V                    | 190.0                               | 190.0  | 190.0  | 190.0  | 190.0  | 190.0 | 190.0 | 190.0 |
| E1-06       | Base Frequency                  | Hz                   | 57.5                                | 57.5   | 57.5   | 57.5   | 57.5   | 57.5  | 57.5  | 57.5  |
| E1-09       | Minimum Output Frequency        | Hz                   | 2.9                                 | 2.9    | 2.9    | 2.9    | 2.9    | 2.9   | 2.9   | 2.9   |
| C5-17       | Motor Inertia                   | kgm <sup>2</sup>     | 0.0022                              | 0.0042 | 0.0081 | 0.0133 | 0.0168 | 0.027 | 0.044 | 0.054 |
| L3-24<br>*J | Motor Accel Time @ Rated Torque | s                    | 0.080                               | 0.081  | 0.078  | 0.088  | 0.066  | 0.070 | 0.085 | 0.071 |
| n5-02       | Motor Inertia Acceleration Time | s                    | 0.080                               | 0.081  | 0.078  | 0.088  | 0.066  | 0.070 | 0.085 | 0.071 |
| n8-49       | Heavy Load Id Current           | %                    | -8.4                                | -11.0  | -10.7  | -10.7  | -9.4   | -22.5 | -22.2 | -16.7 |

\*1 The default setting changes when the setting for o2-04 [Drive Model Selection] changes.

**Table 1.32 SST4 Series Motor Code Setting for Specification of 200 V at 1150 min<sup>-1</sup> (r/min)**

| No.         | Name                             | Unit                 | Motor Code (setting value of E5-01) |       |       |       |       |       |       |       |
|-------------|----------------------------------|----------------------|-------------------------------------|-------|-------|-------|-------|-------|-------|-------|
|             |                                  |                      |                                     |       |       |       |       |       |       |       |
| E5-01       | PM Motor Code Selection          | -                    | 240E                                | 240F  | 2410  | 2412  | 2413  | 2414  | 2415  | 2416  |
|             | Voltage Class                    | V                    | 200                                 | 200   | 200   | 200   | 200   | 200   | 200   | 200   |
|             | Capacity                         | kW                   | 15                                  | 18    | 22    | 30    | 37    | 45    | 55    | 75    |
|             | Motor Rotation Speed             | min <sup>-1</sup>    | 1150                                | 1150  | 1150  | 1150  | 1150  | 1150  | 1150  | 1150  |
| E5-02       | PM Motor Rated Power             | kW                   | 15                                  | 18.50 | 22.00 | 30.00 | 37.00 | 45.00 | 55.00 | 75.00 |
| E5-03       | PM Motor Rated Current (FLA)     | A                    | 55.9                                | 65.4  | 77.0  | 103.5 | 126.0 | 153.1 | 188.5 | 260.4 |
| E5-04       | PM Motor Pole Count              | -                    | 6                                   | 6     | 6     | 6     | 6     | 6     | 6     | 6     |
| E5-05       | PM Motor Resistance (ohms/phase) | Ω                    | 0.083                               | 0.065 | 0.052 | 0.035 | 0.026 | 0.019 | 0.013 | 0.009 |
| E5-06       | PM d-axis Inductance (mH/phase)  | mH                   | 3.50                                | 2.92  | 2.55  | 2.03  | 1.59  | 1.24  | 0.98  | 0.70  |
| E5-07       | PM q-axis Inductance (mH/phase)  | mH                   | 4.23                                | 3.79  | 3.22  | 2.46  | 1.92  | 1.64  | 1.37  | 0.97  |
| E5-09       | PM Back-EMF Vpeak (mV/(rad/s))   | mVs/rad              | 364.5                               | 404.5 | 445.1 | 444.4 | 447.3 | 470.8 | 422.4 | 418.3 |
| E5-24       | PM Back-EMF L-L Vrms (mV/rpm)    | mV/min <sup>-1</sup> | 0.0                                 | 0.0   | 0.0   | 0.0   | 0.0   | 0.0   | 0.0   | 0.0   |
| E1-04       | Maximum Output Frequency         | Hz                   | 57.5                                | 57.5  | 57.5  | 57.5  | 57.5  | 57.5  | 57.5  | 57.5  |
| E1-05       | Maximum Output Voltage           | V                    | 190.0                               | 190.0 | 190.0 | 190.0 | 190.0 | 190.0 | 190.0 | 190.0 |
| E1-06       | Base Frequency                   | Hz                   | 57.5                                | 57.5  | 57.5  | 57.5  | 57.5  | 57.5  | 57.5  | 57.5  |
| E1-09       | Minimum Output Frequency         | Hz                   | 2.9                                 | 2.9   | 2.9   | 2.9   | 2.9   | 2.9   | 2.9   | 2.9   |
| C5-17       | Motor Inertia                    | kgm <sup>2</sup>     | 0.063                               | 0.113 | 0.137 | 0.252 | 0.304 | 0.410 | 0.55  | 0.82  |
| L3-24<br>*J | Motor Accel Time @ Rated Torque  | s                    | 0.061                               | 0.089 | 0.090 | 0.122 | 0.119 | 0.132 | 0.145 | 0.159 |
| n5-02       | Motor Inertia Acceleration Time  | s                    | 0.061                               | 0.089 | 0.090 | 0.122 | 0.119 | 0.132 | 0.145 | 0.159 |
| n8-49       | Heavy Load Id Current            | %                    | -13.7                               | -15.2 | -10.9 | -9.8  | -9.3  | -11.5 | -17.7 | -17.1 |

\*1 The default setting changes when the setting for o2-04 [Drive Model Selection] changes.

## 1.22 Parameters Changed by PM Motor Code Selection

**Table 1.33 SST4 Series Motor Code Setting for Specification of 400 V at 1150 min<sup>-1</sup> (r/min)**

| No.      | Name                             | Unit                 | Motor Code (setting value of E5-01) |        |        |        |        |       |       |
|----------|----------------------------------|----------------------|-------------------------------------|--------|--------|--------|--------|-------|-------|
| E5-01    | PM Motor Code Selection          | -                    | 2432                                | 2433   | 2435   | 2436   | 2438   | 243A  | 243B  |
|          | Voltage Class                    | V                    | 400                                 | 400    | 400    | 400    | 400    | 400   | 400   |
|          | Capacity                         | kW                   | 0.4                                 | 0.75   | 1.5    | 2.2    | 3.7    | 5.5   | 7.5   |
|          | Motor Rotation Speed             | min <sup>-1</sup>    | 1150                                | 1150   | 1150   | 1150   | 1150   | 1150  | 1150  |
| E5-02    | PM Motor Rated Power             | kW                   | 0.4                                 | 0.75   | 1.5    | 2.2    | 3.7    | 5.5   | 7.5   |
| E5-03    | PM Motor Rated Current (FLA)     | A                    | 0.89                                | 1.72   | 3.02   | 4.58   | 7.40   | 10.21 | 13.75 |
| E5-04    | PM Motor Pole Count              | -                    | 6                                   | 6      | 6      | 6      | 6      | 6     | 6     |
| E5-05    | PM Motor Resistance (ohms/phase) | Ω                    | 10.720                              | 6.080  | 4.336  | 2.143  | 1.428  | 1.199 | 0.648 |
| E5-06    | PM d-axis Inductance (mH/phase)  | mH                   | 122.20                              | 61.16  | 70.24  | 46.20  | 33.87  | 41.67 | 21.24 |
| E5-07    | PM q-axis Inductance (mH/phase)  | mH                   | 170.80                              | 97.12  | 90.04  | 60.28  | 42.98  | 69.15 | 33.04 |
| E5-09    | PM Back-EMF Vpeak (mV/(rad/s))   | mVs/rad              | 626.1                               | 626.1  | 703.1  | 727.6  | 699.0  | 861.5 | 759.7 |
| E5-24    | PM Back-EMF L-L Vrms (mV/rpm)    | mV/min <sup>-1</sup> | 0.0                                 | 0.0    | 0.0    | 0.0    | 0.0    | 0.0   | 0.0   |
| E1-04    | Maximum Output Frequency         | Hz                   | 57.5                                | 57.5   | 57.5   | 57.5   | 57.5   | 57.5  | 57.5  |
| E1-05    | Maximum Output Voltage           | V                    | 380.0                               | 380.0  | 380.0  | 380.0  | 380.0  | 380.0 | 380.0 |
| E1-06    | Base Frequency                   | Hz                   | 57.5                                | 57.5   | 57.5   | 57.5   | 57.5   | 57.5  | 57.5  |
| E1-09    | Minimum Output Frequency         | Hz                   | 2.9                                 | 2.9    | 2.9    | 2.9    | 2.9    | 2.9   | 2.9   |
| C5-17    | Motor Inertia                    | kgm <sup>2</sup>     | 0.0022                              | 0.0042 | 0.0081 | 0.0133 | 0.0168 | 0.027 | 0.044 |
| L3-24 *1 | Motor Accel Time @ Rated Torque  | s                    | 0.080                               | 0.081  | 0.078  | 0.088  | 0.066  | 0.070 | 0.085 |
| n5-02    | Motor Inertia Acceleration Time  | s                    | 0.080                               | 0.081  | 0.078  | 0.088  | 0.066  | 0.070 | 0.085 |
| n8-49    | Heavy Load Id Current            | %                    | -8.4                                | -11.0  | -9.9   | -9.0   | -11.4  | -23.2 | -22.1 |

\*1 The default setting changes when the setting for o2-04 [Drive Model Selection] changes.

**Table 1.34 SST4 Series Motor Code Setting for Specification of 400 V at 1150 min<sup>-1</sup> (r/min)**

| No.   | Name                             | Unit              | Motor Code (setting value of E5-01) |       |       |       |       |       |       |
|-------|----------------------------------|-------------------|-------------------------------------|-------|-------|-------|-------|-------|-------|
| E5-01 | PM Motor Code Selection          | -                 | 243D                                | 243E  | 243F  | 2440  | 2442  | 2443  | 2444  |
|       | Voltage Class                    | V                 | 400                                 | 400   | 400   | 400   | 400   | 400   | 400   |
|       | Capacity                         | kW                | 11                                  | 15    | 18    | 22    | 30    | 37    | 45    |
|       | Motor Rotation Speed             | min <sup>-1</sup> | 1150                                | 1150  | 1150  | 1150  | 1150  | 1150  | 1150  |
| E5-02 | PM Motor Rated Power             | kW                | 11.0                                | 15    | 18.50 | 22.00 | 30.00 | 37.00 | 45.00 |
| E5-03 | PM Motor Rated Current (FLA)     | A                 | 19.5                                | 27.7  | 32.7  | 39.2  | 51.8  | 63.0  | 76.6  |
| E5-04 | PM Motor Pole Count              | -                 | 6                                   | 6     | 6     | 6     | 6     | 6     | 6     |
| E5-05 | PM Motor Resistance (ohms/phase) | Ω                 | 0.460                               | 0.325 | 0.260 | 0.209 | 0.140 | 0.106 | 0.076 |
| E5-06 | PM d-axis Inductance (mH/phase)  | mH                | 17.76                               | 12.83 | 11.68 | 10.09 | 8.12  | 6.43  | 4.96  |
| E5-07 | PM q-axis Inductance (mH/phase)  | mH                | 22.72                               | 17.19 | 15.16 | 16.25 | 9.84  | 7.71  | 6.56  |
| E5-09 | PM Back-EMF Vpeak (mV/(rad/s))   | mVs/rad           | 740.4                               | 716.6 | 809.1 | 786.2 | 888.8 | 857.7 | 941.6 |



## 1.22 Parameters Changed by PM Motor Code Selection

| No.         | Name                            | Unit                 | Motor Code (setting value of E5-01) |       |       |       |       |       |       |
|-------------|---------------------------------|----------------------|-------------------------------------|-------|-------|-------|-------|-------|-------|
|             |                                 |                      |                                     |       |       |       |       |       |       |
| E5-24       | PM Back-EMF L-L Vrms (mV/rpm)   | mV/min <sup>-1</sup> | 0.0                                 | 0.0   | 0.0   | 0.0   | 0.0   | 0.0   | 0.0   |
| E1-04       | Maximum Output Frequency        | Hz                   | 57.5                                | 57.5  | 57.5  | 57.5  | 57.5  | 57.5  | 57.5  |
| E1-05       | Maximum Output Voltage          | V                    | 380.0                               | 380.0 | 380.0 | 380.0 | 380.0 | 380.0 | 380.0 |
| E1-06       | Base Frequency                  | Hz                   | 57.5                                | 57.5  | 57.5  | 57.5  | 57.5  | 57.5  | 57.5  |
| E1-09       | Minimum Output Frequency        | Hz                   | 2.9                                 | 2.9   | 2.9   | 2.9   | 2.9   | 2.9   | 2.9   |
| C5-17       | Motor Inertia                   | kgm <sup>2</sup>     | 0.054                               | 0.063 | 0.113 | 0.137 | 0.252 | 0.304 | 0.410 |
| L3-24<br>*J | Motor Accel Time @ Rated Torque | s                    | 0.071                               | 0.061 | 0.089 | 0.090 | 0.122 | 0.119 | 0.132 |
| n5-02       | Motor Inertia Acceleration Time | s                    | 0.071                               | 0.061 | 0.089 | 0.090 | 0.122 | 0.119 | 0.132 |
| n8-49       | Heavy Load Id Current           | %                    | -16.7                               | -20.2 | -15.2 | -27.7 | -9.8  | -10.2 | -11.5 |

\*1 The default setting changes when the setting for o2-04 [Drive Model Selection] changes.

**Table 1.35 SST4 Series Motor Code Setting for Specification of 400 V at 1150 min<sup>-1</sup> (r/min)**

| No.         | Name                             | Unit                 | Motor Code (setting value of E5-01) |       |       |        |        |        |        |
|-------------|----------------------------------|----------------------|-------------------------------------|-------|-------|--------|--------|--------|--------|
|             |                                  |                      |                                     |       |       |        |        |        |        |
| E5-01       | PM Motor Code Selection          | -                    | 2445                                | 2446  | 2447  | 2448   | 2449   | 244A   | 244C   |
|             | Voltage Class                    | V                    | 400                                 | 400   | 400   | 400    | 400    | 400    | 400    |
|             | Capacity                         | kW                   | 55                                  | 75    | 90    | 110    | 132    | 160    | 200    |
|             | Motor Rotation Speed             | min <sup>-1</sup>    | 1150                                | 1150  | 1150  | 1150   | 1150   | 1150   | 1150   |
| E5-02       | PM Motor Rated Power             | kW                   | 55.00                               | 75.00 | 90.00 | 110.00 | 132.00 | 160.00 | 200.00 |
| E5-03       | PM Motor Rated Current (FLA)     | A                    | 93.1                                | 128.1 | 153.1 | 186.5  | 221.9  | 269.8  | 336.5  |
| E5-04       | PM Motor Pole Count              | -                    | 6                                   | 6     | 6     | 6      | 6      | 6      | 6      |
| E5-05       | PM Motor Resistance (ohms/phase) | Ω                    | 0.051                               | 0.032 | 0.026 | 0.015  | 0.012  | 0.009  | 0.007  |
| E5-06       | PM d-axis Inductance (mH/phase)  | mH                   | 3.99                                | 2.97  | 2.44  | 1.87   | 1.49   | 1.41   | 1.22   |
| E5-07       | PM q-axis Inductance (mH/phase)  | mH                   | 5.39                                | 3.90  | 3.23  | 2.46   | 2.08   | 1.88   | 1.51   |
| E5-09       | PM Back-EMF Vpeak (mV/(rad/s))   | mVs/rad              | 853.8                               | 829.6 | 835.6 | 833.4  | 848.6  | 889.1  | 915.0  |
| E5-24       | PM Back-EMF L-L Vrms (mV/rpm)    | mV/min <sup>-1</sup> | 0.0                                 | 0.0   | 0.0   | 0.0    | 0.0    | 0.0    | 0.0    |
| E1-04       | Maximum Output Frequency         | Hz                   | 57.5                                | 57.5  | 57.5  | 57.5   | 57.5   | 57.5   | 57.5   |
| E1-05       | Maximum Output Voltage           | V                    | 380.0                               | 380.0 | 380.0 | 380.0  | 380.0  | 380.0  | 380.0  |
| E1-06       | Base Frequency                   | Hz                   | 57.5                                | 57.5  | 57.5  | 57.5   | 57.5   | 57.5   | 57.5   |
| E1-09       | Minimum Output Frequency         | Hz                   | 2.9                                 | 2.9   | 2.9   | 2.9    | 2.9    | 2.9    | 2.9    |
| C5-17       | Motor Inertia                    | kgm <sup>2</sup>     | 0.55                                | 0.82  | 0.96  | 1.60   | 1.95   | 2.82   | 3.70   |
| L3-24<br>*J | Motor Accel Time @ Rated Torque  | s                    | 0.145                               | 0.159 | 0.155 | 0.211  | 0.214  | 0.256  | 0.268  |
| n5-02       | Motor Inertia Acceleration Time  | s                    | 0.145                               | 0.159 | 0.155 | 0.211  | 0.214  | 0.256  | 0.268  |
| n8-49       | Heavy Load Id Current            | %                    | -15.9                               | -15.7 | -15.7 | -14.7  | -16.5  | -14.1  | -10.3  |

\*1 The default setting changes when the setting for o2-04 [Drive Model Selection] changes.

## 1.22 Parameters Changed by PM Motor Code Selection

---

## Parameter Details

---

|      |                                   |     |
|------|-----------------------------------|-----|
| 2.1  | Section Safety .....              | 184 |
| 2.2  | A: Initialization Parameters..... | 185 |
| 2.3  | b: Application .....              | 204 |
| 2.4  | C: Tuning .....                   | 257 |
| 2.5  | d: Softstarter.....               | 284 |
| 2.6  | E: Motor Parameters.....          | 305 |
| 2.7  | F: Options.....                   | 326 |
| 2.8  | H: Terminal Functions .....       | 367 |
| 2.9  | L: Protection Functions .....     | 443 |
| 2.10 | n: Special Adjustment.....        | 492 |
| 2.11 | o: Keypad-Related Settings .....  | 518 |
| 2.12 | T: Auto-Tuning.....               | 540 |

## 2.1 Section Safety

### DANGER

**Do not ignore the safety messages in this manual.**

If you ignore the safety messages in this manual, it will cause serious injury or death. The manufacturer is not responsible for injuries or damage to equipment.

## 2.2 A: Initialization Parameters

*A parameters [Initialization Parameters]* set the operating environment and operating conditions for the drive.

### ◆ A1: Initialization

*A1 parameters* set the operating environment and operating conditions for the drive. For example, these parameters set the keypad language, the control method, and the parameter access level for the drive.

#### ■ A1-00: Language Selection

| No. (Hex.)             | Name               | Description   | Default (Range) |
|------------------------|--------------------|---|-----------------|
| A1-00<br>(0100)<br>RUN | Language Selection | <div style="display: flex; justify-content: space-between; align-items: center;"> <span>V/f</span> <span>CL-V/f</span> <span>OLV</span> <span>CLV</span> <span>AOLV</span> <span>OLV/PM</span> <span>AOLV/PM</span> <span>CLV/PM</span> <span>EZOLV</span> </div> Sets the language for the LCD keypad. | 0<br>(0 - 12)   |

**Note:**

When you initialize the drive with parameter *A1-03 [Initialize Parameters]*, the drive will not reset this parameter.

**0 : English**

**1 : Japanese**

**2 : German**

**3 : French**

**4 : Italian**

**5 : Spanish**

**6 : Portuguese**

**7 : Chinese**

**8 : Czech**

**9 : Russian**

**10 : Turkish**

**11 : Polish**

**12 : Greek**

#### ■ A1-01: Access Level Selection

| No. (Hex.)             | Name                   | Description  | Default (Range) |
|------------------------|------------------------|--|-----------------|
| A1-01<br>(0101)<br>RUN | Access Level Selection | <div style="display: flex; justify-content: space-between; align-items: center;"> <span>V/f</span> <span>CL-V/f</span> <span>OLV</span> <span>CLV</span> <span>AOLV</span> <span>OLV/PM</span> <span>AOLV/PM</span> <span>CLV/PM</span> <span>EZOLV</span> </div> Sets user access to parameters. The access level controls which parameters the keypad will display, and which parameters the user can set. | 2<br>(0 - 3)    |

#### **0 : Operation Only**

Access to *A1-00*, *A1-01*, *A1-04 [Password]*, and the *U Monitors*.

#### **1 : User Parameters**

Access to *A1-00*, *A1-01*, *A1-04*, and *A2-01 to A2-32 [User Parameters 1 to 32]*.

#### **2 : Advanced Level**

Access to all parameters, but not Expert Mode parameters.

#### **3 : Expert Level**

Access to all parameters including Expert Mode parameters.

Table 2.1 shows which keypad screens are available for each *A1-01* settings.

## 2.2 A: Initialization Parameters

**Table 2.1 Access Level and Available Keypad Screens**

| Mode             | Keypad Screen                 | A1-01 [Access Level Selection] Setting |     |     |     |
|------------------|-------------------------------|--|-----|-----|-----|
|                  |                               | 0                                      | 1   | 2   | 3   |
| Drive Mode       | Monitors                      | Yes                                    | Yes | Yes | Yes |
| Programming Mode | Parameters                    | Yes                                    | Yes | Yes | Yes |
|                  | User Custom Parameters        | No                                     | Yes | Yes | Yes |
|                  | Parameter Backup/Restore      | No                                     | No  | Yes | Yes |
|                  | Modified Parameters/Fault Log | No                                     | No  | Yes | Yes |
|                  | Auto-Tuning                   | No                                     | No  | Yes | Yes |
|                  | Initial Setup Screen          | No                                     | No  | Yes | Yes |
|                  | Diagnostic Tools              | No                                     | No  | Yes | Yes |

**Note:**

- When you use A1-04 and A1-05 [Password Setting] to set a password, you cannot change the values set in A1-01 to A1-03, A1-06, A1-07, or A2-01 to A2-32.
- When H1-xx = 1B [MFDI Function Select = Program Lockout], you must activate the terminal to change parameter settings.
- When you use MEMOBUS/Modbus communications, you must send the Enter command from the controller to the drive and complete the serial communication write process before you can use the keypad to change parameter settings.

### ■ A1-02: Control Method Selection

| No.<br>(Hex.)   | Name                     | Description  | Default<br>(Range) |
|-----------------|--------------------------|--|--------------------|
| A1-02<br>(0102) | Control Method Selection | <input type="checkbox"/> V/f <input type="checkbox"/> CL-V/f <input type="checkbox"/> OLV <input type="checkbox"/> CLV <input type="checkbox"/> AOLV <input type="checkbox"/> OLV/PM <input type="checkbox"/> AOLV/PM <input type="checkbox"/> CLV/PM <input type="checkbox"/> EZOLV<br>Sets the control method for the drive application and the motor. | 2<br>(0 - 8)       |

**Note:**

When you change the A1-02 setting, the parameter values specified by A1-02 are changed to their default values.

Sets the control method for the drive application and the motor.

#### 0 : V/f Control

Use this control method in these applications and conditions:

- For general variable-speed control applications in which a high level of responsiveness or high-precision speed control is not necessary.
- To connect more than one motor to one drive
- When there is not sufficient data to set the motor parameters
- When it is not possible to do Auto-Tuning. The speed control range is 1:40.

#### 1 : V/f Control with Encoder

Use this control method in these applications and conditions:

- For general variable-speed control applications in which a high level of responsiveness or high-precision speed control is not necessary.
- When there is not sufficient data to set the motor parameters
- When it is not possible to do Auto-Tuning. The speed control range is 1:40.

#### 2 : Open Loop Vector

Use this control method for general variable-speed control applications in which high-precision speed control is necessary. In this control method, a feedback signal from the motor is not necessary to have high torque response and high torque when operating at low speeds. The speed control range is 1:120.

#### 3 : Closed Loop Vector

Use this control method for general variable-speed control applications in which these qualities are necessary:

- A high level of responsiveness
- High-precision speed control up to zero speed

- High-precision torque control. A speed feedback signal from the motor is necessary for this control method. The speed control range is 1:1500.

#### 4 : Advanced Open Loop Vector

This is a control method for induction motors. Use this control method for applications in which high-precision speed control is necessary.

This control method has high speed and torque response and high torque when operating at low speeds. The speed control range is 1:200.

#### 5 : PM Open Loop Vector

The drive controls an IPM motor or SPM motor in this control method. Use this control method for general variable-speed control applications in which a high level of responsiveness or high-precision speed control are not necessary. The speed control range is 1:20.

#### 6 : PM Advanced Open Loop Vector

The drive can control an IPM motor in this control method. Use this control method for general variable-speed control applications in which high-precision speed control and torque limit are necessary. The speed control range is 1:20. The speed control range is 1:100 when  $n8-57 = 1$  [*HFI Overlap Selection = Enabled*].

#### 7 : PM Closed Loop Vector

The drive controls a PM motor in this control method. Use this control method for constant torque applications in which high-precision control with a PM motor is necessary. Also use this control method for general variable-speed control applications in which high torque response and high-precision torque control are necessary. A speed feedback signal from the motor is necessary for this control method. The speed control range is 1:1500.

#### 8 : EZ Vector Control

The drive controls induction motors and PM motors in this control method. This control method uses an easier procedure to operate motors with more efficiency. Use this control method for derating torque applications. For example, fans and pumps.

### ■ A1-03: Initialize Parameters

| No.<br>(Hex.)   | Name                  | Description  | Default<br>(Range) |
|-----------------|-----------------------|--|--------------------|
| A1-03<br>(0103) | Initialize Parameters | <input type="checkbox"/> V/f <input type="checkbox"/> CL-V/f <input type="checkbox"/> OLV <input type="checkbox"/> CLV <input type="checkbox"/> AOLV <input type="checkbox"/> OLV/PM <input type="checkbox"/> AOLV/PM <input type="checkbox"/> CLV/PM <input type="checkbox"/> EZOLV<br>Sets parameters to default values. | 0<br>(0 - 3330)    |

#### Note:

- After you initialize the drive, the drive automatically sets  $A1-03 = 0$ .
- User Parameters can save the parameter values for your application and use these values as default values for drive initialization.
- To use the 2 motor switchover function, first turn OFF the terminal to which  $H1-xx = 16$  [*MFDI Function Select = Motor 2 Selection*] is set, then change the  $A1-02$  setting. An incorrect procedure will trigger  $oPE08$  [*Parameter Selection Error*].

#### 0 : No Initialization

##### 1110 : User Initialization

Sets parameters to the values set by the user as user settings. Set  $o2-03 = 1$  [*User Parameter Default Value = Set defaults*] to save the user settings.

You can save the parameter settings that were adjusted for the test run as user-set default values to the drive. Set  $A1-03 = 1110$  to reset to the saved parameter settings.

Follow this procedure to save User Parameter setting values, and to do a User Initialization.

1. Set parameters correctly for the application.
2. Set  $o2-03 = 1$  [*User Parameter Default Value = Set defaults*].  
This saves parameter settings for a User Initialization.  
The drive will then automatically set  $o2-03 = 0$ .
3. When you make changes to the parameter values after you save the settings as User Parameter Settings, the drive will set the parameters to the User Parameter Setting value when you initialize with  $A1-03 = 1110$ .  
When you initialize the drive, the drive sets the parameter values to the User Parameter setting values.

##### 2220 : 2-Wire Initialization

Sets MFDI terminal S1 to Forward Run and terminal S2 to Reverse Run, and resets all parameters to default settings.

## 2.2 A: Initialization Parameters

### 3330 : 3-Wire Initialization

Sets MFDI terminal S1 to Run, terminal S2 to Stop, and terminal S5 to FWD/REV, and resets all parameters to default settings.

The drive will not initialize the parameters in Table 2.2 when  $A1-03 = 2220, 3330$ .

**Table 2.2 Parameters that are not Initialized Using a 2-Wire Sequence or a 3-Wire Sequence**

| No.           | Name   |
|---------------|--|
| A1-00         | Language Selection   |
| A1-02         | Control Method Selection   |
| A1-07         | DriveWorksEZ Function Selection  |
| E1-03         | V/f Pattern Selection  |
| E5-01         | PM Motor Code Selection  |
| E5-02         | PM Motor Rated Power (kW)  |
| E5-03         | PM Motor Rated Current (FLA)   |
| E5-04         | PM Motor Pole Count  |
| E5-05         | PM Motor Resistance (ohms/phase)   |
| E5-06         | PM d-axis Inductance (mH/phase)  |
| E5-07         | PM q-axis Inductance (mH/phase)  |
| E5-09         | PM Back-EMF Vpeak (mV/(rad/s))   |
| E5-11         | Encoder Z-Pulse Offset   |
| E5-24         | PM Back-EMF L-L Vrms (mV/rpm)  |
| E5-25         | Polarity Estimation Timeout  |
| F6-08         | Comm Parameter Reset @Initialize   |
| F6-xx/F7-xx   | Communication Option Parameters<br>Set $F6-08 = 1$ [ <i>Comm Parameter Reset @Initialize = Reset Back to Factory Default</i> ] to initialize communication option card parameters. |
| L8-35         | Installation Method Selection  |
| o2-04         | Drive Model (KVA) Selection  |
| q1-xx - q8-xx | DriveWorksEZ Parameters  |
| r1-xx         | DWEZ Connection 1-20   |

**Note:**

- Set  $A1-06$  [*Application Preset*] to let the drive automatically set the best parameter settings for the selected application. The drive does not initialize  $A1-02$  when  $A1-03 = 2220, 3330$ .
- When  $A1-03 = 2220, 3330$ , the drive automatically set  $A1-05$  [*Password Setting*] = 0000. Make sure that you set the password again for applications where a password is necessary.

### ■ A1-04: Password


| No. (Hex.)   | Name     | Description  | Default (Range)       |
|--------------|----------|--|-----------------------|
| A1-04 (0104) | Password | <div style="display: flex; justify-content: space-between; align-items: center;"> <span>V/f</span> <span>CL-Vf</span> <span>OLV</span> <span>CLV</span> <span>AOLV</span> <span>OLV/PM</span> <span>AOLV/PM</span> <span>CLV/PM</span> <span>EZOLV</span> </div> <p>Entry point for the password set in <math>A1-05</math> [<i>Password Setting</i>]. The user can view the settings of parameters that are locked without entering the password. Enter the correct password in this parameter to change parameter settings.</p> | 0000<br>(0000 - 9999) |

If the password entered in  $A1-04$  does not agree with the password setting in  $A1-05$ , you cannot change these parameters:

- $A1-01$  [*Access Level Selection*]
- $A1-02$  [*Control Method Selection*]
- $A1-03$  [*Initialize Parameters*]
- $A1-06$  [*Application Preset*]
- $A1-07$  [*DriveWorksEZ Function Selection*]



- A2-01 to A2-32 [User Parameter 1 to 32]















To lock parameter settings after making changes without changing the password, enter the incorrect password in A1-04 and push .

### Enter the Password to Unlock Parameters

Use this procedure to unlock parameter settings.










Set the password in A1-05 [Password Setting], and show the Parameter Setting Mode screen on the keypad.

This procedure verifies the password, and makes sure that the parameter settings are unlocked.

1. Push  or  to select "A: Initialization Parameters", then push .
2. Push  or  to select [A1-04], then push .  
You can now change parameter settings.
3. Push  or  to move the digit and enter the password.
4. Push  to confirm the password.  
The drive unlocks the parameters and automatically shows the Parameters Screen.
5. Push  or  to show [A1-02], then push .
6. Push  or  to make sure that you can change the setting value.

Push  (Back) until the keypad shows the Parameter Setup Mode screen.



### ■ A1-05: Password Setting

| No. (Hex.)      | Name             | Description  | Default (Range)       |
|-----------------|------------------|--|-----------------------|
| A1-05<br>(0105) | Password Setting |         <br>Set the password to lock parameters and prevent changes to parameter settings. Enter the correct password in A1-04 [Password] to unlock parameters and accept changes. | 0000<br>(0000 - 9999) |

This parameter can lock these parameter settings:

- A1-01 [Access Level Selection]
- A1-02 [Control Method Selection]
- A1-03 [Initialize Parameters]
- A1-06 [Application Preset]
- A1-07 [DriveWorksEZ Function Selection]
- A2-01 to A2-32 [User Parameter 1 to 32]










#### Note:

- Usually, the keypad will not show A1-05. To show and set A1-05, show A1-04 [Password] and then push  and  on the keypad at the same time.
- After you set A1-05, the keypad will not show it again until you enter the correct password in A1-04. Make sure that you remember the A1-05 setting value. If you do not know the A1-05 setting value, contact Yaskawa or your nearest sales representative.
- When A1-03 = 2220, 3330 [2-Wire Initialization, 3-Wire Initialization], the drive is initialized to A1-05 = 0000. Be sure to set the password again when a password is necessary for the application.
- Change the setting value in A1-05 to change the password. The new setting value becomes the new password.
- When you use the password to unlock and change a parameter, enter a value other than the password in A1-04 to lock the parameter again with the same password.
- If A1-04 ≠ A1-05, MEMOBUS Communication cannot read or write A1-05.

### ■ A1-06: Application Preset

**WARNING!** Sudden Movement Hazard. Check the I/O signals and the external sequences for the drive before you set the Application Preset function. When you set the Application Preset function (A1-06 ≠ 0), it changes the I/O terminal functions for the drive and it can cause equipment to operate unusually. This can cause serious injury or death.

## 2.2 A: Initialization Parameters

| No. (Hex.)      | Name               | Description   | Default (Range) |
|-----------------|--------------------|---|-----------------|
| A1-06<br>(0127) | Application Preset |         <br>Sets the drive to operate in selected application conditions. | 0<br>(0 - 5)    |

The drive software contains the application presets shown below. Set *A1-06* to align with the application to let the drive automatically set the best parameter settings for the selected application. The drive saves parameters frequently used for the application in parameters *A2-01* to *A2-16* [*User Parameters 1 to 16*] for easy configuration and reference in [*User Custom Parameters*] in the main menu.

- Water supply pump
- Conveyor
- Water supply pump
- HVAC fan
- Air compressor

**Note:**

- Before you set *A1-06*, make sure that you set *A1-03* = 2220, 3330 [*Initialize Parameters = 2-Wire Initialization, 3-Wire Initialization*] to initialize parameters.
- It is not possible to change the *A1-06* value. To set an application preset, first set *A1-03* = 2220 to initialize parameters, then make a selection to *A1-06*. If initializing all parameters will cause a problem, do not change the settings.  
If you set *A2-33* = 1 [*User Parameter Auto Selection = Enabled: Auto Save Recent Params*] to set parameters to *A2-17* to *A2-32* [*User Parameters 17 to 32*] automatically, the drive will reset these parameters when you change the *A1-06* setting.

### 0 : General-purpose

The drive saves the parameters in Table 2.3 as user parameters.

**Table 2.3 Parameters Saved as User Parameters with the General-purpose Preset**

| User Parameter No. | Parameter No. Saved | Name                            |
|--------------------|---------------------|---------------------------------|
| A2-01              | A1-02               | Control Method Selection        |
| A2-02              | b1-01               | Frequency Reference Selection 1 |
| A2-03              | b1-02               | Run Command Selection 1         |
| A2-04              | b1-03               | Stopping Method Selection       |
| A2-05              | C1-01               | Acceleration Time 1             |
| A2-06              | C1-02               | Deceleration Time 1             |
| A2-07              | C6-01               | Normal / Heavy Duty Selection   |
| A2-08              | C6-02               | Carrier Frequency Selection     |
| A2-09              | d1-01               | Reference 1                     |
| A2-10              | d1-02               | Reference 2                     |
| A2-11              | d1-03               | Reference 3                     |
| A2-12              | d1-04               | Reference 4                     |
| A2-13              | d1-17               | Jog Reference                   |
| A2-14              | E1-01               | Input AC Supply Voltage         |
| A2-15              | E1-03               | V/f Pattern Selection           |
| A2-16              | E1-04               | Maximum Output Frequency        |
| A2-17              | E1-05               | Maximum Output Voltage          |
| A2-18              | E1-06               | Base Frequency                  |
| A2-19              | E1-09               | Minimum Output Frequency        |
| A2-20              | E1-13               | Base Voltage                    |
| A2-21              | E2-01               | Motor Rated Current             |
| A2-22              | E2-04               | Motor Pole Count                |
| A2-23              | E2-11               | Motor Rated Power (kW)          |

| User Parameter No. | Parameter No. Saved | Name                            |
|--------------------|---------------------|---------------------------------|
| A2-24              | H4-02               | Terminal FM Analog Output Gain  |
| A2-25              | L1-01               | Motor Overload (oL1) Protection |
| A2-26              | L3-04               | Stall Prevention during Decel   |

### 1 : Water Supply Pump 2

The drive automatically sets the parameters in Table 2.4 for a water supply pump application.

**Table 2.4 Best Parameter Settings for Water Supply Pump Applications**

| No.   | Name                           | Optimal Value         |
|-------|--------------------------------|-----------------------|
| A1-02 | Control Method Selection       | 0: V/f Control        |
| b1-04 | Reverse Operation Selection    | 1: Reverse Disabled   |
| C1-01 | Acceleration Time 1            | 1.0 s                 |
| C1-02 | Deceleration Time 1            | 1.0 s                 |
| C6-01 | Normal / Heavy Duty Selection  | 1: Normal Duty Rating |
| E1-03 | V/f Pattern Selection          | V/f Pattern Selection |
| E1-07 | Mid Point A Frequency          | 30.0 Hz               |
| E1-08 | Mid Point A Voltage            | 50.0 V                |
| L2-01 | Power Loss Ride Through Select | 1: Enabled            |
| L3-04 | Stall Prevention during Decel  | 1: Enabled            |

The drive saves the parameters in Table 2.5 as user parameters.

**Table 2.5 Parameters Saved as User Parameters with the Water Supply Pump Preset**

| User Parameter No. | Parameter No. Saved | Name                            |
|--------------------|---------------------|---------------------------------|
| A2-01              | b1-01               | Frequency Reference Selection 1 |
| A2-02              | b1-02               | Run Command Selection 1         |
| A2-03              | b1-04               | Reverse Operation Selection     |
| A2-04              | C1-01               | Acceleration Time 1             |
| A2-05              | C1-02               | Deceleration Time 1             |
| A2-06              | E1-03               | V/f Pattern Selection           |
| A2-07              | E1-07               | Mid Point A Frequency           |
| A2-08              | E1-08               | Mid Point A Voltage             |
| A2-09              | E2-01               | Motor Rated Current             |
| A2-10              | H1-05               | Terminal S5 Function Selection  |
| A2-11              | H1-06               | Terminal S6 Function Selection  |
| A2-12              | H1-07               | Terminal S7 Function Selection  |
| A2-13              | L5-01               | Number of Auto-Restart Attempts |

### 2 : Conveyor

The drive automatically sets the parameters in Table 2.6 for a conveyor application.

**Table 2.6 Best Parameter Settings for Conveyor Applications**

| No.   | Name                     | Optimal Value  |
|-------|--------------------------|----------------|
| A1-02 | Control Method Selection | 0: V/f Control |
| C1-01 | Acceleration Time 1      | 3.0 s          |
| C1-02 | Deceleration Time 1      | 3.0 s          |

## 2.2 A: Initialization Parameters

| No.   | Name                          | Optimal Value        |
|-------|-------------------------------|----------------------|
| C6-01 | Normal / Heavy Duty Selection | 0: Heavy Duty Rating |
| L3-04 | Stall Prevention during Decel | 1: Enabled           |

The drive saves the parameters in Table 2.7 as user parameters.

**Table 2.7 Parameters Saved as User Parameters with the Conveyor Preset**

| User Parameter No. | Parameter No. Saved | Name                            |
|--------------------|---------------------|---------------------------------|
| A2-01              | A1-02               | Control Method Selection        |
| A2-02              | b1-01               | Frequency Reference Selection 1 |
| A2-03              | b1-02               | Run Command Selection 1         |
| A2-04              | C1-01               | Acceleration Time 1             |
| A2-05              | C1-02               | Deceleration Time 1             |
| A2-06              | E2-01               | Motor Rated Current             |
| A2-07              | L3-04               | Stall Prevention during Decel   |

### 3 : Exhaust Fan

The drive automatically sets the parameters in Table 2.8 for an exhaust fan application.

**Table 2.8 Best Parameter Settings for Exhaust Fan Applications**

| No.   | Name                           | Optimal Value         |
|-------|--------------------------------|-----------------------|
| A1-02 | Control Method Selection       | 0: V/f Control        |
| b1-04 | Reverse Operation Selection    | 1: Reverse Disabled   |
| C6-01 | Normal / Heavy Duty Selection  | 1: Normal Duty Rating |
| E1-03 | V/f Pattern Selection          | V/f Pattern Selection |
| E1-07 | Mid Point A Frequency          | 30.0 Hz               |
| E1-08 | Mid Point A Voltage            | 50.0 V                |
| L2-01 | Power Loss Ride Through Select | 1: Enabled            |
| L3-04 | Stall Prevention during Decel  | 1: Enabled            |

The drive saves the parameters in Table 2.9 as user parameters.

**Table 2.9 Parameters Saved as User Parameters with the Exhaust Fan Preset**

| User Parameter No. | Parameter No. Saved | Name                            |
|--------------------|---------------------|---------------------------------|
| A2-01              | b1-01               | Frequency Reference Selection 1 |
| A2-02              | b1-02               | Run Command Selection 1         |
| A2-03              | b1-04               | Reverse Operation Selection     |
| A2-04              | b3-01               | Speed Search at Start Selection |
| A2-05              | C1-01               | Acceleration Time 1             |
| A2-06              | C1-02               | Deceleration Time 1             |
| A2-07              | E1-03               | V/f Pattern Selection           |
| A2-08              | E1-07               | Mid Point A Frequency           |
| A2-09              | E1-08               | Mid Point A Voltage             |
| A2-10              | E2-01               | Motor Rated Current             |
| A2-11              | H1-05               | Terminal S5 Function Selection  |
| A2-12              | H1-06               | Terminal S6 Function Selection  |
| A2-13              | H1-07               | Terminal S7 Function Selection  |
| A2-14              | L5-01               | Number of Auto-Restart Attempts |

#### 4 : HVAC Fan

The drive automatically sets the parameters in Table 2.10 for an HVAC fan application.

**Table 2.10 Best Parameter Settings for HVAC Applications**

| No.   | Name                              | Optimal Value                       |
|-------|-----------------------------------|-------------------------------------|
| A1-02 | Control Method Selection          | 0: V/f Control                      |
| b1-04 | Reverse Operation Selection       | 1: Reverse Disabled                 |
| b1-17 | Run Command at Power Up           | 1: Enabled                          |
| C6-01 | Normal / Heavy Duty Selection     | 1: Normal Duty Rating               |
| C6-02 | Carrier Frequency Selection       | 3: 8.0 kHz                          |
| H2-03 | Terminal M5-M6 Function Selection | 39: Watt Hour Pulse Output          |
| L2-01 | Power Loss Ride Through Select    | 2: Enabled while CPU Power Active   |
| L8-03 | Overheat Pre-Alarm Selection      | 4: Operate at Reduced Speed (L8-19) |
| L8-38 | Carrier Frequency Reduction       | 2: Enabled for All Speeds           |

The drive saves the parameters in Table 2.11 as user parameters.

**Table 2.11 Parameters Saved as User Parameters with the HVAC Preset**

| User Parameter No. | Parameter No. Saved | Name                            |
|--------------------|---------------------|---------------------------------|
| A2-01              | b1-01               | Frequency Reference Selection 1 |
| A2-02              | b1-02               | Run Command Selection 1         |
| A2-03              | b1-03               | Stopping Method Selection       |
| A2-04              | b1-04               | Reverse Operation Selection     |
| A2-05              | C1-01               | Acceleration Time 1             |
| A2-06              | C1-02               | Deceleration Time 1             |
| A2-07              | C6-02               | Carrier Frequency Selection     |
| A2-08              | d2-01               | Frequency Reference Upper Limit |
| A2-09              | d2-02               | Frequency Reference Lower Limit |
| A2-10              | E1-03               | V/f Pattern Selection           |
| A2-11              | E1-04               | Maximum Output Frequency        |
| A2-12              | E2-01               | Motor Rated Current             |
| A2-13              | H3-11               | Terminal A2 Gain Setting        |
| A2-14              | H3-12               | Terminal A2 Bias Setting        |
| A2-15              | L2-01               | Power Loss Ride Through Select  |
| A2-16              | o4-12               | kWh Monitor Initialization      |

#### 5 : Air Compressor

The drive automatically sets the parameters in Table 2.12 for an air compressor application.

**Table 2.12 Best Parameter Settings for Air Compressor Applications**

| No.   | Name                          | Optimal Value         |
|-------|-------------------------------|-----------------------|
| A1-02 | Control Method Selection      | 0: V/f Control        |
| b1-04 | Reverse Operation Selection   | 1: Reverse Disabled   |
| C1-01 | Acceleration Time 1           | 5.0 s                 |
| C1-02 | Deceleration Time 1           | 5.0 s                 |
| C6-01 | Normal / Heavy Duty Selection | 0: Heavy Duty Rating  |
| E1-03 | V/f Pattern Selection         | V/f Pattern Selection |

## 2.2 A: Initialization Parameters

| No.   | Name                           | Optimal Value |
|-------|--------------------------------|---------------|
| L2-01 | Power Loss Ride Through Select | 1: Enabled    |
| L3-04 | Stall Prevention during Decel  | 1: Enabled    |

The drive saves the parameters in Table 2.13 as user parameters.

**Table 2.13 Parameters Saved as User Parameters with the Air Compressor Preset**

| User Parameter No. | Parameter No. Saved | Name                            |
|--------------------|---------------------|---------------------------------|
| A2-01              | b1-01               | Frequency Reference Selection 1 |
| A2-02              | b1-02               | Run Command Selection 1         |
| A2-03              | b1-04               | Reverse Operation Selection     |
| A2-04              | C1-01               | Acceleration Time 1             |
| A2-05              | C1-02               | Deceleration Time 1             |
| A2-06              | E1-03               | V/f Pattern Selection           |
| A2-07              | E1-07               | Mid Point A Frequency           |
| A2-08              | E1-08               | Mid Point A Voltage             |
| A2-09              | E2-01               | Motor Rated Current             |

### ■ Notes for Elevator Applications

When using the drive for elevator applications, read the safety descriptions and precautions, and safely and correctly use the device.

#### Conditions to Open and Close the Brake

Set  $L4-07 = 0$  [*Speed Agree Detection Selection = No Detection during Baseblock*] to open and close the holding brake.

When  $L4-07 = 1$  [*Detection Always Enabled*], the output frequency increases when you input the Run command although the external baseblock command is input. Because of this, speed detection operates and will open the brake signal.

- Set Related Parameters

Table 2.14 shows examples of parameter settings to use the MFDO terminal (M1-M2) as the holding brake open and close signal.

**Table 2.14 Holding Brake Open and Close Signal Setting Example**

| Brake Open and Close Signal  |                    | Brake Open and Close Level Adjust |  | Applicable Control Methods (A1-02 Setting Value) |         |         |          |                          |
|------------------------------|--------------------|-----------------------------------|--|--|---------|---------|----------|--------------------------|
| Signal Name                  | Parameter Settings | Signal Name                       | Parameter Settings                     | V/f (0)  | OLV (2) | CLV (3) | AOLV (4) | CLV/PM (7) <sup>*1</sup> |
| Frequency (FOUT) Detection 2 | L4-07 = 0          | Speed Agree Detection Level       | L4-01 = 1.0 Hz to 3.0 Hz <sup>*2</sup> | x  | x       | x       | x        | x                        |
|                              | H2-01 = 5          | Speed Agree Detection Width       | L4-02 = 0.0 Hz to 0.5 Hz <sup>*3</sup> |  |         |         |          |                          |
| During Frequency Output      | H2-01 = 37         | DC Injection/Zero Speed Threshold | b2-01 = 0.1 Hz to 0.5 Hz               | x  | x       | x       | x        | x                        |

- \*1 When  $A1-02 = 7$  [*PM Closed Loop Vector*], make sure that the motor can rotate before you do Auto-Tuning or switch the encoder. Refer to Closed Loop Vector Control for induction motors for information about the signal to use and the adjustment method.
- \*2 When  $A1-02 = 2$  [*Open Loop Vector*], it is the usual setting range. When  $A1-02 = 0$  [*V/f Control*], set  $L4-01$  to the rated slip frequency of the motor + approximately 0.5 Hz. If you set the value too low, motor torque will not be sufficient and it will cause motor rollback. Configure the parameters to meet the following conditions at the same time. However, if the setting is too high, an overshooting is likely to occur at start.
- $L4-01 > E1-09$  [*Minimum Output Frequency*]
  - $L4-01 > L4-02$  [*Speed Agree Detection Width*]
- \*3 Use  $L4-02$  to adjust the detection width of Frequency Detection 2. If rollback occurs when the motor is stopped, change the frequency to approximately 0.1 Hz.

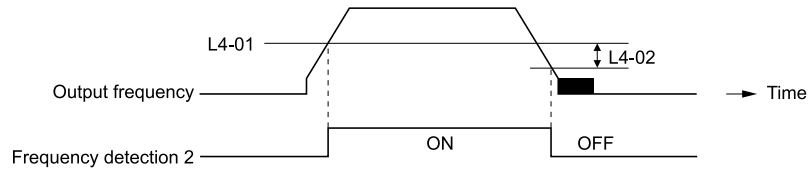


Figure 2.1 Frequency Detection 2

**Sequence Circuit Configuration**

Use these conditions to set the circuit for the open/close sequence of the holding brake:

- Set the sequence-side operation conditions to activate terminal M1-M2 and open the holding brake.
- Set the sequence to close the holding brake in an emergency if the drive detects a fault.
- Set the sequence to open the holding brake when you enter an increase or decrease command.

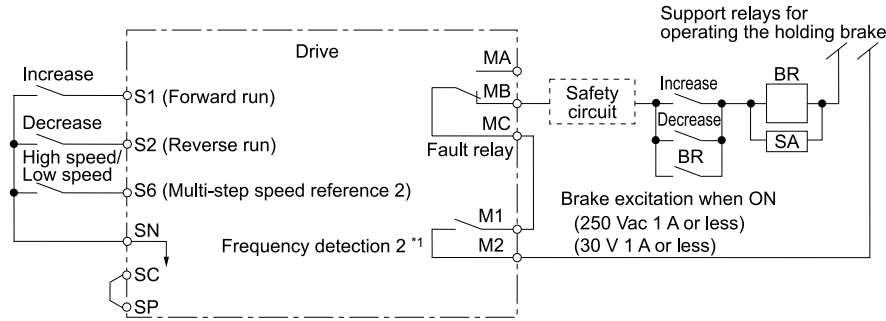


Figure 2.2 Sequence Circuit Configuration Diagram

\*1  $L4-07 = 0$  [Speed Agree Detection Selection = No Detection during Baseblock] or During Frequency Output

**Time Chart**

Figure 2.3 shows the open/close sequence of the holding brake.

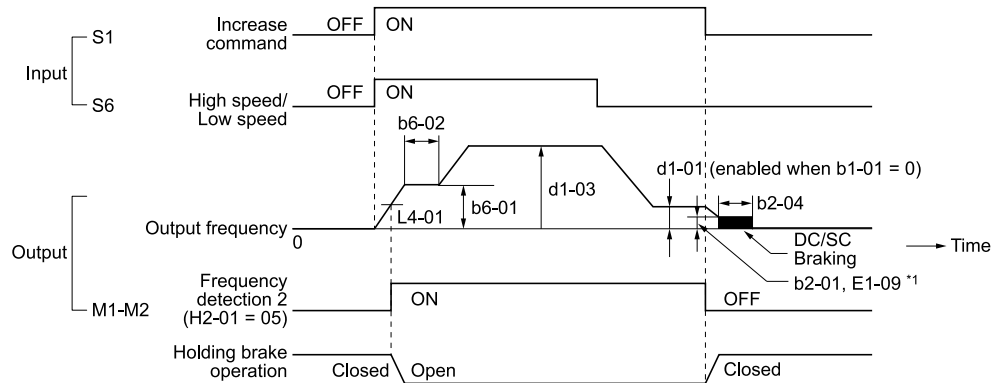
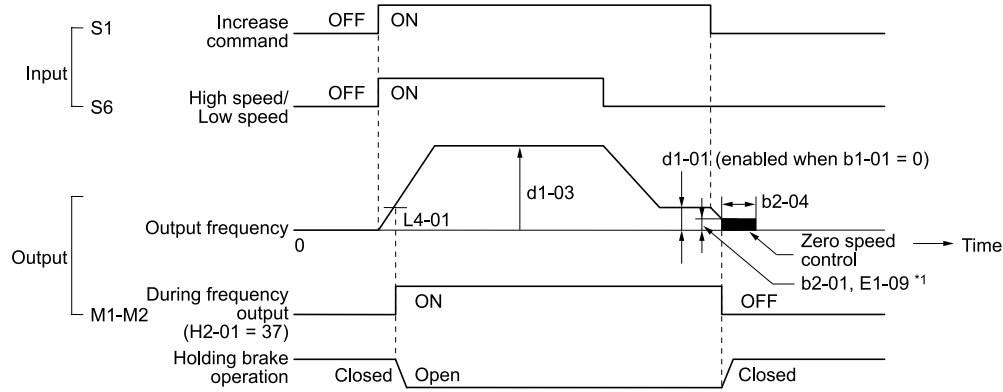


Figure 2.3 Holding Brake Open and Close Sequence Time Chart (V/f, CL-V/f, OLV)

\*1 Start braking from the higher set frequency between  $b2-01$  [DC Injection/Zero SpeedThreshold] or  $E1-09$  [Minimum Output Frequency].

## 2.2 A: Initialization Parameters



**Figure 2.4 Holding Brake Open and Close Sequence Time Chart (CLV, CLV/PM)**

\*1 Start braking from the higher set frequency between *b2-01* [DC Injection/Zero SpeedThreshold] or *E1-09* [Minimum Output Frequency].

### Notes on when Using Other Functions

| Function                             | Notes   |
|--------------------------------------|---|
| Decel stall prevention function      | <p>When you connect a braking resistor to discharge the regenerative power to the drive, set <i>L3-04</i> = 0 [Stall Prevention during Decel = Disabled].</p> <p><b>Note:</b></p> <ul style="list-style-type: none"> <li>If <i>L3-04</i> = 1 [General Purpose], it is possible that the drive will not stop in the set deceleration time. Do not change the default settings of these related parameters:</li> <li>• <i>L3-01</i> = 1 [Stall Prevention during Accel = Enabled]</li> <li>• <i>L3-05</i> = 1 [Stall Prevention during RUN = Deceleration Time 1 (C1-02)]</li> </ul>  |
| Auto-Tuning for Induction Motors     | <ul style="list-style-type: none"> <li>• When <i>A1-02</i> = 2, 3, 4 [Control Method Selection = Open Loop Vector; Closed Loop Vector; Advanced Open Loop Vector], Auto-Tune the motor before you operate the drive.</li> <li>• Disconnect the drive from the motor to do Rotational Auto-Tuning.</li> <li>• Auto-Tuning runs automatically for approximately 1 minute. Do not do Auto-Tuning with the motor engaged in the elevator system.</li> </ul> <p><b>Note:</b></p> <ul style="list-style-type: none"> <li>• If you cannot disconnect the motor from the machine, do Stationary Auto-Tuning. During this time, the drive automatically measures the necessary motor data. If the motor test report or the motor nameplate is not available, use Stationary Auto-Tuning. Do Stationary Auto-Tuning for Line-to-Line Resistance for better torque characteristics at low speeds in the V/f Control mode.</li> <li>• When you do Stationary Auto-Tuning, the drive energizes the motor and the motor stays stopped.</li> <li>• To Auto-Tune a specialized motor, for example a wound motor, prepare a motor test report before Auto-Tuning and make sure that the motor parameter <i>E2-xx</i> is not too different than the value in the test report.</li> </ul>  |
| Auto-Tuning for PM Motors            | <p>You must set the motor data in the drive to run a PM motor.</p> <ul style="list-style-type: none"> <li>• When you use a PM motor recommended by Yaskawa Input the motor code in <i>E5-01</i>. <i>E5</i> and other related motor parameters will be automatically set to the optimal values.</li> <li>• When you use a non-Yaskawa PM motor Do Auto-Tuning. <ul style="list-style-type: none"> <li>– When the motor nameplate or motor test report is available, enter the PM motor parameters directly with PM Motor Parameter Settings.</li> <li>– If the motor nameplate or motor test report is not available, and the motor cannot rotate, do PM Stationary Auto-Tuning.</li> <li>– If the motor nameplate or motor test report is not available, and the motor can rotate, do PM Rotational Auto-Tuning.</li> <li>– When you replace an encoder, make sure that the motor can rotate and do Z Pulse Offset Tuning or PM Rotational Auto-Tuning.</li> </ul> </li> </ul> <p><b>Note:</b></p> <ul style="list-style-type: none"> <li>• Use in Closed Loop Vector Control for PM mode.</li> <li>• When you do Auto-Tuning or replace the encoder, make sure that the motor can rotate.</li> <li>• Set the Encoder Z-Pulse Offset.</li> <li>• Refer to Closed Loop Vector Control for induction motors for information about the signal to use and the adjustment method.</li> </ul> |
| Braking Resistor Overheat Protection | <p>When you use a braking resistor other than the optional Yaskawa braking resistor unit (LKEB-series), this function uses the thermal overload relay to detect braking resistor overheat. Load a sequence program that cuts the drive input power supply when the braking resistor overheats.</p> <p><b>Note:</b></p> <p>Refer to 627 when you load the sequence circuit.</p>  |
| Continuous operation function        | <p>Do not use the momentary power loss continuous operation function and the Auto Restart function. If you use these functions, there is a risk that the motor will coast to a stop if the brake is open when there is a momentary power loss and the drive is operating or if there is a fault.</p> <p>Set the these parameters:</p> <ul style="list-style-type: none"> <li>• <i>L2-01</i> = 0 [Power Loss Ride Through Select = Disabled]</li> <li>• <i>L5-01</i> = 0 [Number of Auto-Restart Attempts = 0]</li> </ul>  |
| Torque limit function                | <p>The motor rated torque sets the value for <i>L7-01</i> to <i>L7-04</i> [Torque Limit]. If there will not be sufficient torque during start up, replace the drive with a larger capacity drive and set the torque limit between 200% and 300%. The <i>L7-01</i> to <i>L7-04</i> default setting is 200%.</p>  |



| Function   | Notes   |
|--|---|
| I/O phase loss protection, overtorque detection function | To stop a fall because of motor phase loss, set these parameters. <ul style="list-style-type: none"> <li>• L8-05 = 1 [Input Phase Loss Protection Sel = Enabled]</li> <li>• L8-07 = 1 [Output Phase Loss Protection Sel = Fault when one phase is lost]</li> <li>• L6-01, L6-04 = 1 to 8 [Torque Detection Selection 1/2 = oL @ Speed Agree - Alarm only to UL @ RUN - Fault]</li> <li>• L6-02, L6-05 [Torque Detection Level 1/2]</li> <li>• L6-03, L6-06 [Torque Detection Time 1/2]</li> </ul> <b>Note:</b><br>Use precautions, for example fall detection, on the machine side.   |
| External baseblock command                               | <ul style="list-style-type: none"> <li>• If you enter the external baseblock signal set in H1-01 to H1-08 = 8 or 9 [Terminal S1 to S8 Function Selection = Baseblock Command] during run, the motor immediately coasts to stop. When you enter a baseblock command while the motor is operating, make sure that it is necessary.</li> <li>• When you use an external baseblock command for the fast stop and operation start up interlocks, load the sequence to lock the holding brake when you enter the external baseblock command.</li> <li>• If you enter the external baseblock command and then immediately remove it, the drive will not output the voltage in the time set in L2-03 [Minimum Baseblock Time]. Do not use an external baseblock command for applications that have frequent Run/Stop commands.</li> </ul>   |
| Acceleration and deceleration times                      | If you set the acceleration and deceleration times for the drive side too short and you do not add the mechanical operation delay time of the holding brake, the holding brake could operate late, or there could be overcurrent at start up, the brake could grind, or the motor could roll back when it stops. In these conditions, use Dwell Reference at Start/Time and DC Injection Braking at Stop to adjust the holding brake timing.  |
| Electromagnetic contactor on the drive output side       | Usually you must not install the electromagnetic contactor between the drive and motor. When you must install an electromagnetic contactor to use one drive to switchover more than one motor, follow these precautions: <ul style="list-style-type: none"> <li>• Load a sequence that opens and closes the electromagnetic contactor when these two conditions are satisfied at the same time, unless there is an emergency:                             <ul style="list-style-type: none"> <li>– The holding brake is fully closed</li> <li>– The drive terminals for H2-xx = 8 or 1B [MFDO Function Select = During Baseblock] are activated</li> </ul> </li> <li>• If you open and close the electromagnetic contactor during motor control or during DC Injection Braking (or zero speed control), the surge voltage and the motor direct input current can cause the drive to detect faults.</li> <li>• When you use an electromagnetic contactor between the drive and motor, set L8-07 = 1 or 2 [Output Phase Loss Protection Sel = Fault when one phase is lost, Fault when two phases are lost].</li> </ul> |

**Adjustments Relating to Control**

When there is oscillation, rollback, or other control problems, adjust the parameters as specified by the control method.

V/f Control and Closed Loop V/f Control on page 197 shows only the frequently adjusted parameters.

**Note:**

Torque and speed response for high-resistance and high-slip motors are slow. Adjust the torque and speed response to increase them. Low impedance (low-slip) motors will hunt and oscillate. Adjust the torque and speed response to increase them.

**V/f Control and Closed Loop V/f Control**

While in V/f Control, do not use C3-01 [Slip Compensation Gain].

While in Closed Loop V/f Control, continue to use default settings for C5-01 to C5-05 [ASR Parameters].

Significantly altering the default settings will likely cause oscillation.

**Table 2.15 Adjustment of Drive Control (V/f Control and Closed Loop V/f Control Methods)**

| Adjustment description   | Parameter Number                        | Possible Solutions   | Default | Recommended Setting |
|--|---|--|---------|---------------------|
| <ul style="list-style-type: none"> <li>• Prevent hunting and oscillation at middle-range speeds (10 Hz to 40 Hz)</li> </ul>  | n1-02 [Hunting Prevention Gain Setting] | <ul style="list-style-type: none"> <li>• If the torque is not sufficient with heavy loads, decrease the setting.</li> <li>• If there is hunting or oscillation with light loads, increase the setting.</li> </ul>                          | 1.00    | 0.50 - 2.00         |
| <ul style="list-style-type: none"> <li>• Increasing motor excitation sound</li> <li>• Hunting and oscillation suppression at low speeds and middle-range speeds</li> </ul> | C6-02 [Carrier Frequency Selection]     | <ul style="list-style-type: none"> <li>• If there is a loud motor excitation sound, increase the setting value.</li> <li>• If there is hunting or oscillation at low speeds or middle-range speeds, decrease the setting value.</li> </ul> | *1      | 1 - F               |
| <ul style="list-style-type: none"> <li>• Increase torque at low speeds (10 Hz or lower)</li> <li>• Prevent hunting and oscillation</li> </ul>                              | C4-01 [Torque Compensation Gain]        | <ul style="list-style-type: none"> <li>• If the torque is not sufficient at low speeds, increase the setting value.</li> <li>• If there is hunting or oscillation with light loads, decrease the setting value.</li> </ul>                 | 1.00    | 0.50 - 1.50         |

## 2.2 A: Initialization Parameters

| Adjustment description   | Parameter Number               | Possible Solutions   | Default      | Recommended Setting |
|--|--------------------------------|--|--------------|---------------------|
| <ul style="list-style-type: none"> <li>Increase torque at low speeds</li> <li>Prevent shock during start up</li> </ul> | E1-08 [Mid Point A Voltage]    | <ul style="list-style-type: none"> <li>If the torque is not sufficient at low speeds, increase the setting value.</li> <li>If there is a large shock during start up, decrease the setting value.</li> </ul> | 15.0 V *2 *3 | 13.0 V to 16.0 V *3 |
|  | E1-10 [Minimum Output Voltage] |  | 9.0 V *2 *3  | 7.0 V to 10.0 V *3  |

\*1 The default setting changes when the settings for C6-01 [Normal / Heavy Duty Selection] and o2-04 [Drive Model (KVA) Selection] change.

\*2 The default setting changes when the settings for A1-02 [Control Method Selection] and E1-03 [V/f Pattern Selection] change.

\*3 This is the setting for 200 V class drives. Multiply the voltage by 2 for 400 V class drives.

### Open Loop Vector Control Method

Do not adjust parameter C4-01 [Torque Compensation Gain]. Keep this parameter at its default setting.

If you cannot get speed accuracy during regeneration, set C3-04 = 1 [Slip Compensation at Regen = Enabled Above 6Hz]. If you cannot get speed accuracy at high speeds, set C3-05 = 1 [Output Voltage Limit Selection = Enabled].

**Table 2.16 Adjustment of Drive Control (Open Loop Vector Control Method)**

| Adjustment description   | Parameter Number                          | Possible Solutions  | Default   | Recommended Setting |
|--|---|---|-----------|---------------------|
| <ul style="list-style-type: none"> <li>Torque, increase speed response</li> <li>Prevent hunting and oscillation at middle-range speeds (10 Hz to 40 Hz)</li> </ul>   | n2-01 [Automatic Freq Regulator Gain]     | <ul style="list-style-type: none"> <li>If torque and speed response are slow, decrease the setting value.</li> <li>If there is hunting or oscillation, increase the setting value.</li> </ul>                   | 1.00      | 0.50 - 2.00         |
| <ul style="list-style-type: none"> <li>Torque, increase speed response</li> <li>Prevent hunting and oscillation</li> </ul>   | C4-02 [Torque Compensation Delay Time] *1 | <ul style="list-style-type: none"> <li>If torque and speed response are slow, decrease the setting value.</li> <li>If there is hunting or oscillation, increase the setting value.</li> </ul>                   | 20 ms     | 20 ms to 100 ms     |
| <ul style="list-style-type: none"> <li>Increase speed response</li> <li>Increase speed stability</li> </ul>  | C3-02 [Slip Compensation Delay Time]      | <ul style="list-style-type: none"> <li>When speed response is slow, decrease the setting value.</li> <li>If speed is not stable, increase the setting value.</li> </ul>   | 200 ms    | 100 ms to 500 ms    |
| <ul style="list-style-type: none"> <li>Improve speed accuracy</li> </ul>   | C3-01 [Slip Compensation Gain]            | <ul style="list-style-type: none"> <li>If speed is too slow, increase the setting value.</li> <li>If speed is too fast, decrease the setting value.</li> </ul>  | 1.0       | 0.5 - 1.5           |
| <ul style="list-style-type: none"> <li>Increasing motor excitation sound</li> <li>Prevent hunting and oscillation at low-range speeds (10 Hz to or lower)</li> </ul> | C6-02 [Carrier Frequency Selection]       | <ul style="list-style-type: none"> <li>If there is a loud motor excitation sound, increase the setting value.</li> <li>If there is hunting or oscillation at low speeds, decrease the setting value.</li> </ul> | *2        | 1 - F               |
| <ul style="list-style-type: none"> <li>Increase torque and speed response at low speeds</li> <li>Prevent shock during start up</li> </ul>                            | E1-08 [Mid Point A Voltage]               | <ul style="list-style-type: none"> <li>If the torque and speed response are slow, increase the setting value.</li> <li>If there is a large shock during start up, decrease the setting value.</li> </ul>        | 11.0 V *3 | 12.0 V to 13.0 V *3 |
|  | E1-10 [Minimum Output Voltage]            |   | 2.0 V *3  | 2.0 V to 3.0 V *3   |

\*1 If the value for C4-02 [Torque Compensation Delay Time] is high, the current can increase during start up. Adjust and check the current during start up.

\*2 The default setting changes when the settings for C6-01 [Normal / Heavy Duty Selection] and o2-04 [Drive Model (KVA) Selection] change.

\*3 This is the setting for 200 V class drives. Multiply the voltage by 2 for 400 V class drives.

### Closed Loop Vector Control Method

**Table 2.17 Adjustment of Drive Control (Closed Loop Vector Control Method)**

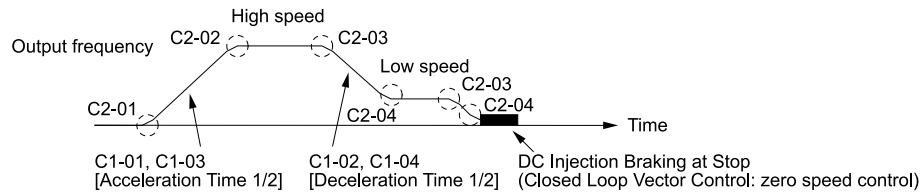
| Adjustment description   | Parameter Number                | Possible Solutions  | Default | Recommended Setting |
|--|---------------------------------|---|---------|---------------------|
| <ul style="list-style-type: none"> <li>Torque, increase speed response</li> <li>Prevent hunting and oscillation</li> </ul> | C5-01 [ASR Proportional Gain 1] | <ul style="list-style-type: none"> <li>If the torque and speed response are slow, increase the setting value.</li> <li>If there is hunting or oscillation, decrease the setting value.</li> </ul> | 20.00   | 10.00 - 50.00       |
|  | C5-03 [ASR Proportional Gain 2] |   |         |                     |
| <ul style="list-style-type: none"> <li>Torque, increase speed response</li> <li>Prevent hunting and oscillation</li> </ul> | C5-02 [ASR Integral Time 1]     | <ul style="list-style-type: none"> <li>If torque and speed response are slow, decrease the setting value.</li> <li>If there is hunting or oscillation, increase the setting value.</li> </ul>     | 0.500 s | 0.300 s to 1.000 s  |
|  | C5-04 [ASR Integral Time 2]     |   |         |                     |

| Adjustment description  | Parameter Number                      | Possible Solutions   | Default                   | Recommended Setting         |
|---|---------------------------------------|--|---------------------------|-----------------------------|
| Change the ASR proportional gain and ASR integral time in accordance with the output frequency. | C5-07 [ASR Gain Switchover Frequency] | If you cannot establish ASR proportional gain or integral time for low speed or high speed, switch as specified by the output frequency. | 0.0 Hz<br>(Do not switch) | 0.0 Hz to Maximum frequency |
| • Prevent hunting and oscillation   | C5-06 [ASR Delay Time]                | • If there is unsatisfactory machine rigidity and oscillation is possible, increase the setting value.                                   | 0.004 s                   | 0.004 s to 0.020 s          |

**Elevator Start/Stop and Accel/Decel Time Shock Reduction**

**S-Curve Characteristics, Accel & Decel Time**

| Adjustment Parameter       | Name                          |
|----------------------------|-------------------------------|
| C1-01, C1-03, C1-05, C1-07 | Acceleration Time 1 to 4      |
| C1-02, C1-04, C1-06, C1-08 | Deceleration Time 1 to 4      |
| C2-01                      | S-Curve Time @ Start of Accel |
| C2-02                      | S-Curve Time @ End of Accel   |
| C2-03                      | S-Curve Time @ Start of Decel |
| C2-04                      | S-Curve Time @ End of Decel   |



**Figure 2.5 S-curve Characteristics, Accel & Decel Time**

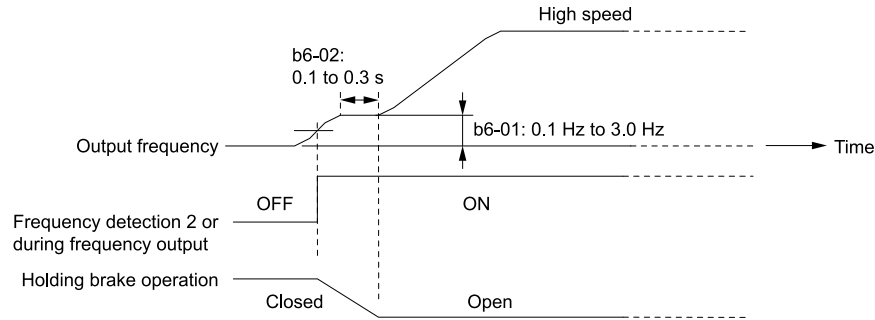
**Note:**

- When decreased operation times are necessary for the application, for example with cranes and hoists, do not use S-curve characteristic times.
- The default setting for C2-04 [S-Curve Time @ End of Decel] will be 0.00 seconds. The default setting for other S-curve characteristics will be 0.20 seconds. Set the acceleration/deceleration times and S-curve characteristic time correctly for acceleration/deceleration start up and end. The recommended setting of the S-curve characteristics time is 0.2 to 1.0 seconds.
- When you use the C1-11 [Accel/Decel Time Switchover Freq], you can switch the acceleration/deceleration rate automatically during acceleration/deceleration. The default setting is disabled.  
When the Output Frequency  $\geq$  C1-11, operate at the acceleration and deceleration times set in C1-01 and C1-02  
When the Output Frequency  $<$  C1-11, operate at the acceleration and deceleration times set in C1-07 and C1-08
- During low speed operation, if the Output Frequency  $<$  E1-09 [Minimum Output Frequency] in the S-Curve Time @ Start of Decel, the drive will cancel the S-curve characteristics and will do DC Inject Braking at Stop (zero speed control).

**Dwell Function at Start**

| Adjustment Parameter | Name                     |
|----------------------|--------------------------|
| b6-01                | Dwell Reference at Start |
| b6-02                | Dwell Time at Start      |
| H2-xx = 5            | Frequency Detection 2    |

## 2.2 A: Initialization Parameters



**Figure 2.6 Dwell Function at Start**

**Note:**

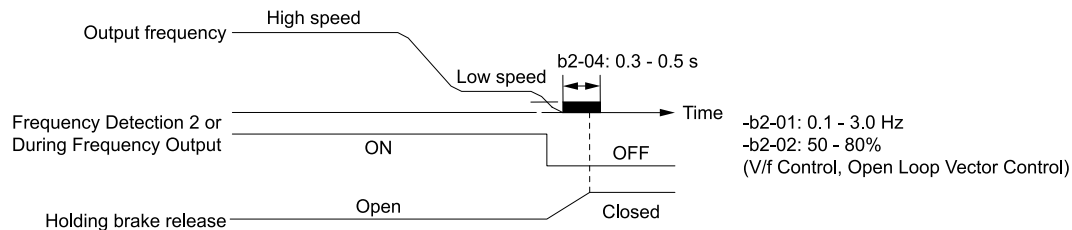
- If the mechanical operation of the holding brake is slow, use the Dwell Function at Start to prevent brake grinding (friction). Accelerate after the brake is fully open.
- When you use V/f Control and Open Loop Vector Control modes, set *b6-01 [Dwell Reference at Start] > Frequency Detection 2 (brake open frequency)*.
- If the motor torque is not sufficient during start up, use the DC Inject Braking function to secure the motor current (torque) before you start the motor.
  - b2-02 [DC Injection Braking Current]* recommended setting: 50% to 80% (V/f Control or Open Loop Vector Control)
  - b2-03 [DC Inject Braking Time at Start]* recommended setting: 0.2 s to 0.5 s

### DC Injection Braking at Stop, Zero Speed Control Function

**Note:**

If you disconnect a drive when it is controlling the motor or during DC Injection Braking (Zero speed level), a voltage surge can trigger a fault. When you use an electromagnetic contactor between the drive and motor, set *L8-07 = 1 or 2 [Output Phase Loss Protection Sel = Fault when one phase is lost, Fault when two phases are lost]*. If it necessary to disconnect the motor and drive when you stop the elevator, fully close the holding brake and disconnect the drive during baseblock (i.e., while the baseblock signal is ON). This does not apply for emergency conditions.

| Adjustment Parameter | Name                             |
|----------------------|----------------------------------|
| b2-01                | DC Injection/Zero SpeedThreshold |
| b2-02                | DC Injection Braking Current     |
| b2-04                | DC Inject Braking Time at Stop   |
| H2-xx = 5            | Frequency Detection 2            |



**Figure 2.7 DC Injection Braking at Stop, Zero Speed Control Function**

**Note:**

- If the mechanical operation of the holding brake is slow, use DC Injection Braking (zero speed control when set to closed loop vector) until the brake is fully closed to prevent rollback.
- If you cannot hold the load with DC Injection Braking when it is stopped in V/f Control and Open Loop Vector Control modes, use Dwell Function at Stop.
  - b6-03 [Dwell Reference at Stop]*: Minimum output frequency to 3.0 Hz  
When Frequency Detection 2 is OFF, it is less than *L4-01 [Speed Agree Detection Level] - L4-02 [Speed Agree Detection Width]*.
  - b6-04 [Dwell Time at Stop]* recommended setting: 0.3 s to 0.5 s
  - b2-04 [DC Inject Braking Time at Stop]* recommended setting: 0.0 s

### Torque Compensation (Torque Bias)

This function enters the torque compensation (torque bias) signal that matches a set load from the MFAI terminal in Closed Loop Vector Control to decrease the overshoot when you open and close the brake. You must detect the load

and motoring/regeneration on the machine side before you use the function. If there is a polarity error, shock can increase.

| Item                           | Description  |
|--------------------------------|--|
| Sequence Circuit Configuration | <p>H3-05 (Terminal A3 Signal Level Select) = 1 (-10 to +10 V)<br/> H3-06 (Terminal A3 Function Selection) = 14 [Torque Compensation (Torque Bias)]<br/> Fine tune by H3-07 and H3-08</p>   |
| Time chart: Increase           | <p>Enter the analog signal as the torque compensation (torque bias) signal as specified by the load quantity before drive operation until drive operation completes. The default setting is 10 V/100% torque.<br/> Enter a positive polarity during a motoring load, and enter a negative polarity during a regenerative load.</p> |
| Time chart: Decrease           | <p>Enter the analog signal as the torque compensation (torque bias) signal as specified by the load quantity before drive operation until drive operation completes. The default setting is 10 V/100% torque.<br/> Enter a negative polarity during a motoring load, and enter a positive polarity during a regenerative load.</p> |

Parameter Details

## 2.2 A: Initialization Parameters

**Note:**

- Holds through an external source to not change the torque compensation signal during run. If you change the torque compensation signal during run, the motor can oscillate.
- When you set motor reverse to the increase command and set motor forward to the decrease command, the polarity of the torque compensation signal will reverse.

### Analog Input FilterTime Constant

- Minimize the effects of noise.
- Change H3-13 [*Analog Input FilterTime Constant*] to a range of 0.01 s to 0.10 s.

### Startup Current Check

When you do a test run, set L8-41 = 1 [*High Current Alarm Selection = Enabled*] and use U4-13 [*Peak Hold Current*] and a clamp ammeter with the machine under load and not under load to check the motor current during start up.

If the motor torque is not sufficient during start up or if the timing between the motor and the holding brake is unsatisfactory and causes the motor to lock, a large quantity of current will flow. In these conditions, adjust the parameters again and decrease the load to decrease the current to less than 150%. If the current flow is more than 150% of the drive rated current, the heat stress on the IGBTs will decrease the service life of drive parts.

To decrease the effects of heat stress, decrease the carrier frequency of the drive to 2.0 kHz to 2.5 kHz for applications where low audible noise is not required.

### Overvoltage Suppression Function

The overvoltage suppression function is designed to prevent an overvoltage trip in a situation in which a braking resistor is not used with a regenerative load. If the overvoltage suppression function is enabled, the regeneration torque reference within the drive is automatically controlled during regeneration.

**Note:**

## ■ A1-07: DriveWorksEZ Function Selection

| No. (Hex.)   | Name                            | Description  | Default (Range) |
|--------------|---------------------------------|--|-----------------|
| A1-07 (0128) | DriveWorksEZ Function Selection | <input type="checkbox"/> V/f <input type="checkbox"/> CL-V/f <input type="checkbox"/> OLV <input type="checkbox"/> CLV <input type="checkbox"/> AOLV <input type="checkbox"/> OLV/PM <input type="checkbox"/> AOLV/PM <input type="checkbox"/> CLV/PM <input type="checkbox"/> EZOLV<br>Sets the drive to operate with DriveWorksEZ. | 0<br>(0 - 2)    |

DriveWorksEZ is a simple visual programming tool that lets you connect function blocks to customize the drive and add PLC functions.

**Note:**

- DriveWorksEZ will overwrite drive settings when it uses MFDI/MFDO and MFAI/MFAO. When you use DriveWorksEZ to make changes to the drive, the changes will stay after you disable DriveWorksEZ.
- For more information about DriveWorksEZ, contact Yaskawa or your nearest sales representative.

### 0 : DWEZ Disabled

### 1 : DWEZ Enabled

### 2 : Enabled/Disabled wDigital Input

Set H1-xx = 9F [*MFDI Function Select = DWEZ Disable*]. Deactivate the digital input to enable programs made with DriveWorksEZ and activate the terminal to disable the programs.

## ■ A1-11: Firmware Update Lock

| No. (Hex.)          | Name                 | Description  | Default (Range) |
|---------------------|----------------------|--|-----------------|
| A1-11 (111D) Expert | Firmware Update Lock | <input type="checkbox"/> V/f <input type="checkbox"/> CL-V/f <input type="checkbox"/> OLV <input type="checkbox"/> CLV <input type="checkbox"/> AOLV <input type="checkbox"/> OLV/PM <input type="checkbox"/> AOLV/PM <input type="checkbox"/> CLV/PM <input type="checkbox"/> EZOLV<br>Protects the drive firmware. Enabling the protection makes it impossible to update the drive firmware. | 0<br>(0, 1)     |

### 0 : Disabled

Lock is disabled.

### 1 : Enabled

Lock is enabled.

### ■ A1-12: Bluetooth ID

| No. (Hex.)      | Name         | Description  | Default (Range)    |
|-----------------|--------------|--|--------------------|
| A1-12<br>(1564) | Bluetooth ID | <b>V/f</b> <b>CL-V/f</b> <b>OLV</b> <b>CLV</b> <b>AOLV</b> <b>OLV/PM</b> <b>AOLV/PM</b> <b>CLV/PM</b> <b>EZOLV</b><br>Sets the password necessary to use Bluetooth to control the drive with a smartphone or tablet. | -<br>(0000 - 9999) |

### ◆ A2: User Parameters

You can register frequently used parameters and recently changed parameters here to access them quickly. You can show the registered parameters in [User Custom Parameters] in the main menu.

### ■ A2-01 to A2-32: User Parameters 1 to 32

| No. (Hex.)                      | Name                    | Description   | Default (Range)   |
|---------------------------------|-------------------------|---|---|
| A2-01 to A2-32<br>(0106 - 0125) | User Parameters 1 to 32 | <b>V/f</b> <b>CL-V/f</b> <b>OLV</b> <b>CLV</b> <b>AOLV</b> <b>OLV/PM</b> <b>AOLV/PM</b> <b>CLV/PM</b> <b>EZOLV</b><br>You can select a maximum of 32 parameters for the drive and set them to parameters <i>A2-01 to A2-32</i> . The [User Parameters] section of the keypad main menu shows the set parameters. You can immediately access these set parameters. | Parameters in General-Purpose Setup Mode<br>(Determined by A1-06) |

**Note:**

- Settings for *A2-01 to A2-32* change when the *A1-06 [Application Preset]* value changes.
- You must set *A1-01 = 1 [Access Level Selection = User Parameters]* to access parameters *A2-01 to A2-32*.
- When *A1-07 = 1 or 2 [DriveWorksEZ Function Selection = DWEZ Enabled or Enabled/Disabled wDigital Input]*, the drive saves *qx-xx [DriveWorksEZ Parameters]* to *A2-01 to A2-32*.

The drive saves these parameters to *A2-01 to A2-32*.

- The drive saves a maximum of 32 parameters.

**Note:**

Set *A1-01 = 2 [Advanced Level]* or *A1-01 = 3 [Expert Level]* to register the necessary parameters.

- The drive automatically saves changed parameters to *A2-17 to A2-32*.

**Note:**

Set *A2-33 = 1 [User Parameter Auto Selection = Enabled]*.

### ■ A2-33: User Parameter Auto Selection

| No. (Hex.)      | Name                          | Description  | Default (Range)               |
|-----------------|-------------------------------|--|-------------------------------|
| A2-33<br>(0126) | User Parameter Auto Selection | <b>V/f</b> <b>CL-V/f</b> <b>OLV</b> <b>CLV</b> <b>AOLV</b> <b>OLV/PM</b> <b>AOLV/PM</b> <b>CLV/PM</b> <b>EZOLV</b><br>Sets the automatic save feature for changes to parameters <i>A2-17 to A2-32 [User Parameters 17 to 32]</i> . | Determined by A1-06<br>(0, 1) |

### 0 : Disabled: Manual Entry Required

Set User Parameters manually.

### 1 : Enabled: Auto Save Recent Parm

The drive automatically registers changed parameter *A2-17 to A2-32*. The drive automatically saves the most recently changed parameter to *A2-17*, and saves a maximum of 16 parameters. After the drive registers 16 parameters, when you save a new parameter, the drive will remove a parameter from the User Parameter list to make space for the new parameter. The drive removes parameters with First In, First Out.

You can show the registered parameters in [User Custom Parameters] in the main menu.

**Note:**

In General-Purpose Setup Mode, the drive registers parameters starting from *A2-27* because parameters *A2-26* and lower are already registered by default.

## 2.3 b: Application

*b* parameters set the following functions.

- Frequency reference source/Run command source
- Stopping method settings
- DC Injection Braking
- Speed Search
- Timer Function
- PID control
- Dwell function
- Droop control
- Energy Savings Control
- Zero Servo Control

### ◆ b1: Operation Mode Selection

*b1* parameters set the operation mode for the drive.

#### ■ b1-01: Frequency Reference Selection 1

| No. (Hex.)      | Name                            | Description  | Default (Setting Range) |
|-----------------|---------------------------------|--|-------------------------|
| b1-01<br>(0180) | Frequency Reference Selection 1 | <br>Sets the input method for the frequency reference. | 1<br>(0 - 4)            |

**Note:**

- Push on the keypad to set the input mode to LOCAL and enter the frequency reference from the keypad.
- When the drive receives a Run command when the frequency reference is 0 Hz or less than the *E1-09* [Minimum Output Frequency] value, on the keypad will flash. Examine the setting for the frequency reference input and enter a value  $\geq$  E1-09.

#### 0 : Keypad

Use the keypad to enter the frequency reference.

Use and on the keypad to change the frequency reference.

#### 1 : Analog Input

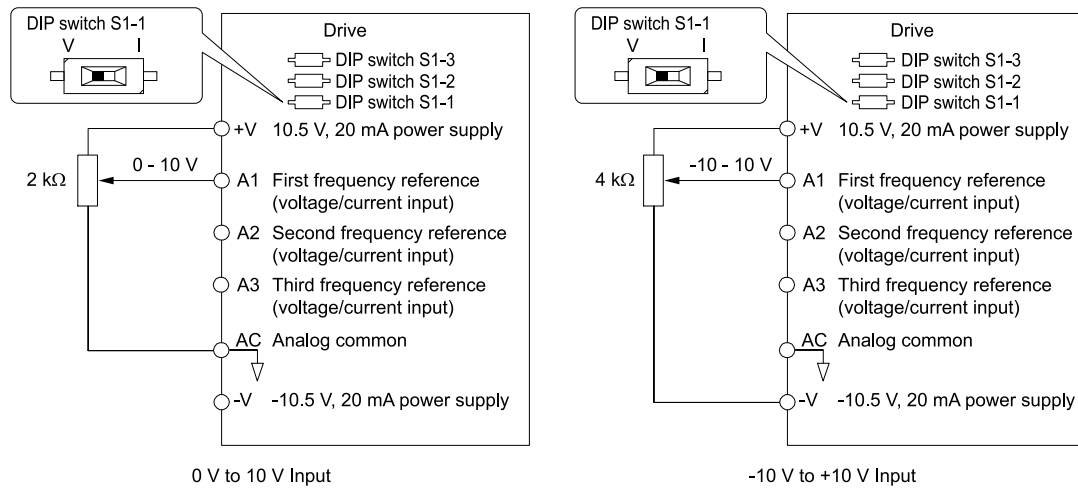
Use MFAI terminals A1, A2, and A3 to input an analog frequency reference with a voltage or current input signal.

- Voltage Input  
Refer to Table 2.18 to use a voltage signal input to one of the MFAI terminals.

**Table 2.18 Frequency Reference Voltage Input**

| Terminal | Terminal Signal Level | Parameter Settings     |                               |       |       | Note   |
|----------|-----------------------|------------------------|-------------------------------|-------|-------|--|
|          |                       | Signal Level Selection | Function Selection            | Gain  | Bias  |  |
| A1       | 0 - 10 V              | H3-01 = 0              | H3-02 = 0<br>[Frequency Bias] | H3-03 | H3-04 | Set DIP switch S1-1 to "V" for voltage input.  |
|          | -10 - +10 V           | H3-01 = 1              |                               |       |       |  |
| A2       | 0 - 10 V              | H3-09 = 0              | H3-10 = 0<br>[Frequency Bias] | H3-11 | H3-12 | Set DIP switch S1-2 to "V" for voltage input.  |
|          | -10 - +10 V           | H3-09 = 1              |                               |       |       |  |
| A3       | 0 - 10 V              | H3-05 = 0              | H3-06 = 0<br>[Frequency Bias] | H3-07 | H3-08 | Set DIP switch S1-3 to "V" for voltage input.<br>Set DIP switch S4 to "AI" for analog input. |
|          | -10 - +10 V           | H3-05 = 1              |                               |       |       |  |





**Figure 2.8 Example of Setting the Frequency Reference with a Voltage Signal to Terminal A1**

**Note:**

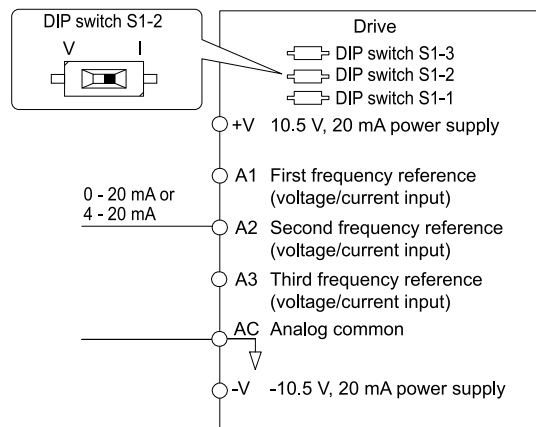
You can also use this diagram to wire terminals A2 and A3.

- **Current Input**

Refer to Table 2.19 to use a current signal input to one of the MFAI terminals.

**Table 2.19 Frequency Reference Current Input**

| Terminal | Signal Level  | Parameter Settings     |                               |       |       | Note   |
|----------|---------------|------------------------|-------------------------------|-------|-------|--|
|          |               | Signal Level Selection | Function Selection            | Gain  | Bias  |  |
| A1       | 4 mA to 20 mA | H3-01 = 2              | H3-02 = 0<br>[Frequency Bias] | H3-03 | H3-04 | Set DIP switch S1-1 to "I" for current input.  |
|          | 0 - 20 mA     | H3-01 = 3              |                               |       |       |  |
| A2       | 4 mA to 20 mA | H3-09 = 2              | H3-10 = 0<br>[Frequency Bias] | H3-11 | H3-12 | Set DIP switch S1-2 to "I" for current input.  |
|          | 0 - 20 mA     | H3-09 = 3              |                               |       |       |  |
| A3       | 4 mA to 20 mA | H3-05 = 2              | H3-06 = 0<br>[Frequency Bias] | H3-07 | H3-08 | Set DIP switch S1-3 to "I" for current input.<br>Set DIP switch S4 to "AI" for analog input. |
|          | 0 - 20 mA     | H3-05 = 3              |                               |       |       |  |



**Figure 2.9 Example of Setting the Frequency Reference with a Current Signal to Terminal A2**

**Note:**

You can also use this diagram to wire terminals A1 and A3.

Changing between Master and Auxiliary Frequency References

Use the multi-step speed reference function to change the frequency reference input between terminals A1, A2, and A3.

**2 : Memobus/Modbus Communications**

## 2.3 b: Application

Use MEMOBUS/Modbus communications to enter the frequency reference.

### 3 : Option PCB

Use a communications option card or input option card connected to the drive to enter the Run command. Refer to the instruction manual included with the option card to install and set the option card.

**Note:**

If  $b1-01 = 3$  but no connected option card, then  $oPE05$  [Run Cmd/Freq Ref Source Sel Err] will flash on the keypad.

### 4 : Pulse Train Input

Use a pulse train signal from the pulse train input terminal RP to enter the frequency reference. Do this procedure to make sure that the pulse train signal is operating correctly.

1. Set  $b1-01 = 4$ ,  $H6-01 = 0$  [Terminal RP Pulse Train Function = Frequency Reference].
2. Set  $H6-02$  [Terminal RP Frequency Scaling] to the number of pulses that determine 100% of the frequency reference.
3. Enter a pulse train signal on the terminal RP and make sure that the keypad shows a correct frequency reference.


### ■ b1-02: Run Command Selection 1

| No. (Hex.)   | Name                    | Description  | Default (Range) |
|--------------|-------------------------|--|-----------------|
| b1-02 (0181) | Run Command Selection 1 | <br>Sets the input method for the Run command. | 1 (0 - 3)       |

### 0 : Keypad

Use the keypad to enter the Run command. You can use the JOG operation or the FWD/REV commands from the keypad.

**Note:**

The keypad's  is lit while the keypad is the Run command source.

### 1 : Digital Input

Use the control circuit terminals to enter the Run command. Select the input method for the Run command with an  $H1-xx$  parameter.

Set  $H1-xx = 0, 40$  to  $43$  [3-Wire Sequence, Run Command (2-Wire Sequence)]. The default setting is 2-wire sequence 1.

- 2-wire Sequence 1  
This sequence has two input types: FWD/Stop and REV/Stop. Set  $A1-03 = 2220$  [Initialize Parameters = 2-Wire Initialization] to initialize the drive and set terminals S1 and S2 for a 2-wire sequence.
- 2-wire Sequence 2  
This sequence has two input types: Run/Stop and FWD/REV.
- 3-Wire Sequence  
This sequence has three input types: Run, Stop, and FWD/REV. Set  $A1-03 = 3330$  [Initialize Parameters = 3-Wire Initialization] to initialize the drive and set terminals S1, S2, and S5 for a 3-wire sequence.

### 2 : Memobus/Modbus Communications

Use MEMOBUS/Modbus communications to enter the Run command.

### 3 : Option PCB

Use a communications option card or input option card connected to the drive to enter the Run command. Refer to the instruction manual included with the option card to install and set the option card.

**Note:**

If  $b1-02 = 3$  but no connected option card, then  $oPE05$  [Run Cmd/Freq Ref Source Sel Err] will flash on the keypad.

## ■ b1-03: Stopping Method Selection

| No. (Hex.)   | Name                      | Description   | Default (Range) |
|--------------|---------------------------|---|-----------------|
| b1-03 (0182) | Stopping Method Selection | <div style="display: flex; gap: 5px;"> <span>V/f</span> <span>CL-V/f</span> <span>OLV</span> <span>CLV</span> <span>AOLV</span> <span>OLV/PM</span> <span>AOLV/PM</span> <span>CLV/PM</span> <span>EZOLV</span> </div> Sets the method to stop the motor after removing a Run command or entering a Stop command. | 0<br>(0 - 3)    |

### Note:

When  $A1-02 = 3, 4, 5, 6, 7, 8$  [Control Method Selection = CLV, AOLV, OLV/PM, AOLV/PM, CLV/PM, EZOLV], the setting range is 0, 1, 3.

Select the applicable stopping method for the application from these four options:

### 0 : Ramp to Stop

Enter the Stop command or turn OFF the Run command for the drive to perform motor deceleration stop.

The drive ramps the motor to stop as specified by the deceleration time. The default setting for the deceleration time is  $C1-02$  [Deceleration Time 1]. The actual deceleration time changes as the load conditions change (for example, mechanical loss and inertia).

If the output frequency is less than or equal to the value set in  $b2-01$  [DC Injection/Zero SpeedThreshold] during deceleration, the drive will do DC Injection Braking, Zero Speed Control, or Short Circuit Braking, as specified by the control method.

#### • Ramp to Stop with V/f, AOLV, CL-V/f, and OLV Control Methods

Parameter  $b2-01$  sets the frequency to start DC Injection Braking at stop. If the output frequency is less than or equal to the value set in  $b2-01$  during deceleration, then the drive will perform DC Injection Braking for the time set in  $b2-04$  [DC Inject Braking Time at Stop].

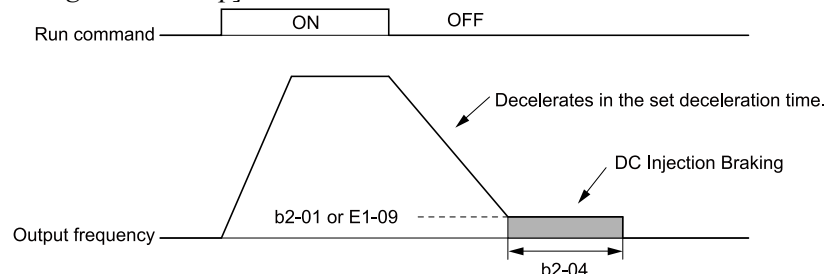


Figure 2.10 Ramp to Stop with V/f, AOLV, CL-V/f, and OLV Control Methods

### Note:

When  $b2-01 \leq E1-09$  [Minimum Output Frequency], the drive will start DC Injection Braking from the frequency set in  $E1-09$ .

#### • Ramp to Stop with OLV/PM, AOLV/PM, and EZOLV Control Methods

Parameter  $b2-01$  sets the frequency to start Short Circuit Braking. When the output frequency is less than or equal to the value set in  $b2-01$  during deceleration, then the drive will do Short Circuit Braking for the time set in  $b2-13$  [Short Circuit Brake Time @ Stop]. When  $b2-04 \neq 0$ , the drive will do DC Injection Braking for the time set in  $b2-04$  when Short Circuit Braking is complete.

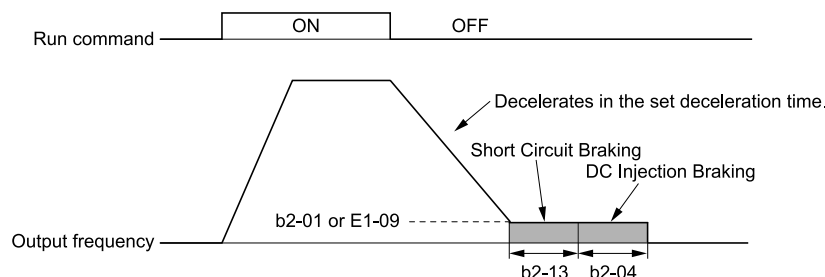


Figure 2.11 Ramp to Stop with OLV/PM, AOLV/PM, and EZOLV Control Methods

### Note:

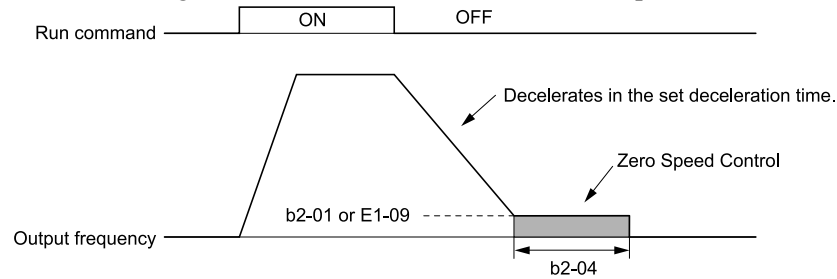
When  $b2-01 \leq E1-09$ , the drive will start Short Circuit Braking from the frequency set in  $E1-09$ .

If  $b2-01 = 0$  Hz and  $E1-09 = 0$  Hz, the drive will not do Short Circuit Braking.

#### • Ramp to Stop in CLV and CLV/PM Control Methods

## 2.3 b: Application

Parameter *b2-01* sets the frequency to start Zero Speed Control at stop. When the output frequency is less than or equal to the value set in *b2-01* during deceleration, the drive will do Zero Speed Control for the time set in *b2-04*.



**Figure 2.12 Ramp to Stop in CLV and CLV/PM Control Methods**

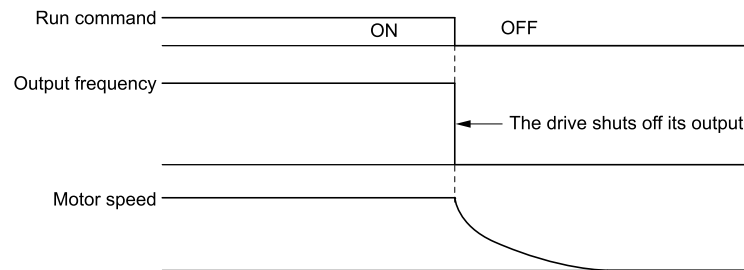
**Note:**

When  $b2-01 \leq E1-09$ , the drive will start Zero Speed Control from the frequency set in *E1-09*.

### 1 : Coast to Stop

When you enter the Stop command or turn OFF the Run command, the drive turns OFF the output and coasts the motor to stop.

Load conditions will have an effect on the deceleration rate as the motor coasts to stop (for example, mechanical loss and inertia).



**Figure 2.13 Coast to Stop**

**Note:**

The drive ignores the Run command for the time set in *L2-03* [Minimum Baseblock Time] when the Stop command is entered or when the Run command is switched OFF. Do not enter the Run command until the motor comes to a complete stop. Use DC Injection or Speed Search to restart the motor before it stops.

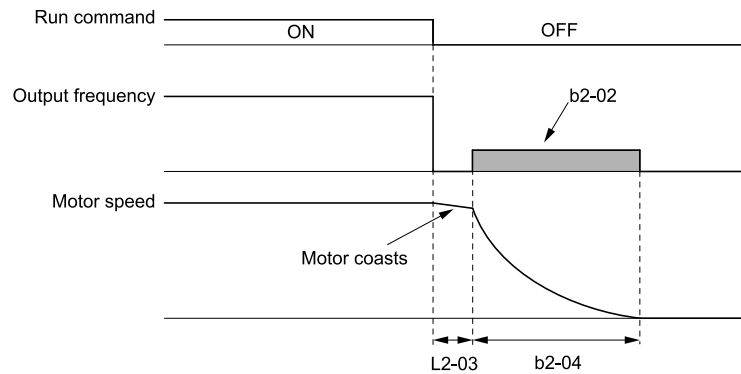
### 2 : DC Injection Braking to Stop

When you enter the Stop command or turn OFF the Run command, the drive turns OFF the output for the time set in *L2-03*. The drive waits for the minimum baseblock time and then injects the amount of DC current into the motor set in *b2-02* [DC Injection Braking Current] to stop the motor with DC current.

DC Injection Braking stops the motor more quickly than coast to stop.

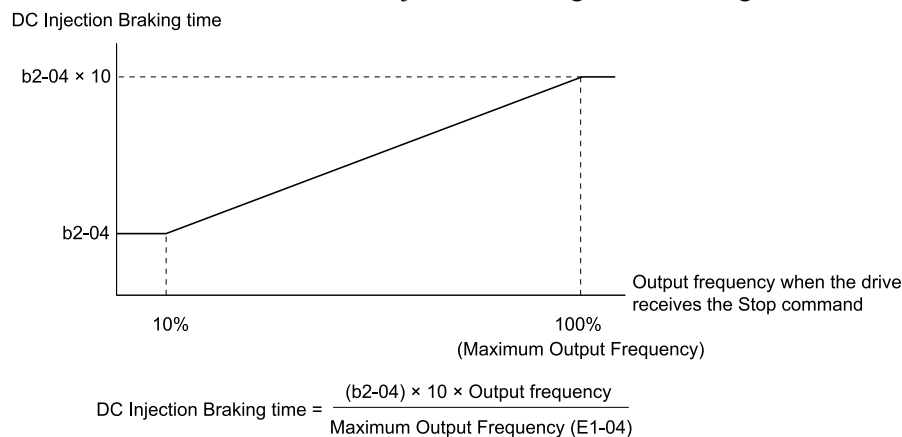
**Note:**

If  $A1-02 = 3, 4, 5, 6, \text{ or } 7$ , DC Injection Braking to Stop is not available.



**Figure 2.14 DC Injection Braking to Stop**

The value set in *b2-04* and the output frequency when the drive receives the Stop command determine the DC Injection Braking time. The drive calculates the DC Injection Braking time as in Figure 2.15.



**Figure 2.15 DC Injection Braking Time and Output Frequency**

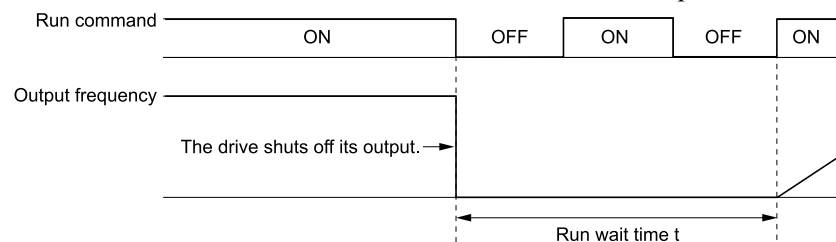
**Note:**

Set *L2-03* to a high value that will not trigger *oC [Overcurrent]* when the drive uses DC Injection Braking to stop the motor.

**3 : Coast to Stop with Timer**

When you enter the Stop command or turn OFF the Run command, the drive turns OFF the output and coasts the motor to stop. The drive ignores the Run command until the “Run wait time” *t* is expired.

To start the drive again, enter the Run command after the “Run wait time” *t* is expired.



**Figure 2.16 Coast to Stop with Timer**

The active deceleration time and the output frequency when drive receives the Stop command determine the length of “Run wait time” *t*.

## 2.3 b: Application

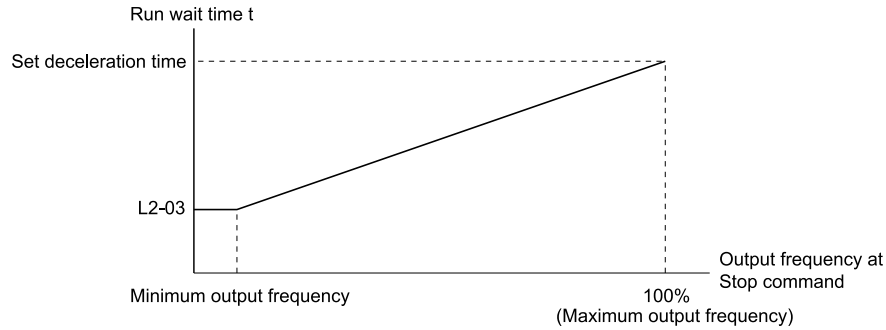


Figure 2.17 Run Wait Time and Output Frequency

### ■ b1-04: Reverse Operation Selection

| No. (Hex.)   | Name                        | Description  | Default (Range) |
|--------------|-----------------------------|--|-----------------|
| b1-04 (0183) | Reverse Operation Selection | <input type="checkbox"/> V/f <input type="checkbox"/> CL-V/f <input type="checkbox"/> OLV <input checked="" type="checkbox"/> CLV <input type="checkbox"/> AOLV <input type="checkbox"/> OLV/PM <input type="checkbox"/> AOLV/PM <input type="checkbox"/> CLV/PM <input type="checkbox"/> EZOLV<br>Sets the reverse operation function. Disable reverse operation in fan or pump applications where reverse rotation is dangerous. | 0 (0, 1)        |

When reverse operation is prohibited, the drive will not accept a Reverse operation command.

#### 0 : Reverse Enabled

The drive will accept a Reverse operation command.

#### 1 : Reverse Disabled

The drive will not accept a Reverse operation command.

### ■ b1-05: Operation Below Minimum Freq

| No. (Hex.)   | Name                         | Description  | Default (Range) |
|--------------|------------------------------|--|-----------------|
| b1-05 (0184) | Operation Below Minimum Freq | <input type="checkbox"/> V/f <input type="checkbox"/> CL-V/f <input type="checkbox"/> OLV <input checked="" type="checkbox"/> CLV <input type="checkbox"/> AOLV <input type="checkbox"/> OLV/PM <input type="checkbox"/> AOLV/PM <input type="checkbox"/> CLV/PM <input type="checkbox"/> EZOLV<br>Sets the drive operation when the frequency reference decreases to less than the value set in E1-09 [Minimum Output Frequency]. | 0 (0 - 3)       |

#### 0 : Operate at Frequency Reference

When the frequency reference is less than the value set in E1-09, the drive will continue to operate the motor as specified by the frequency reference.

If the motor speed is less than or equal to the value set in b2-01 [DC Injection/Zero Speed Threshold] when you enter the Stop command (or deactivate the Run command), the drive will do Zero Speed Control for the time set in b2-04 [DC Inject Braking Time at Stop] and then turn OFF its output.

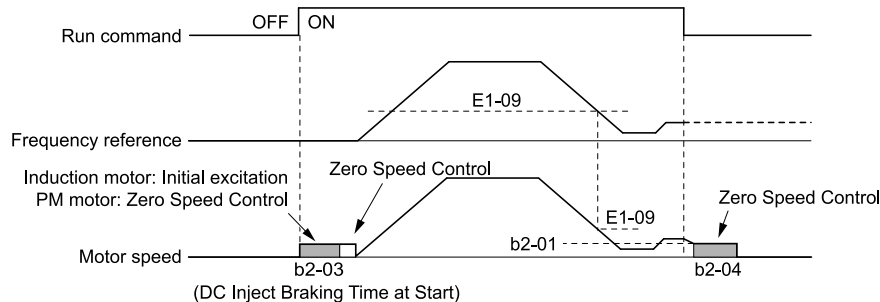


Figure 2.18 Operate at the Frequency Reference

#### 1 : Coast to Stop

If the frequency reference is less than the value set in E1-09, the drive stops motor voltage output and the motor coasts to stop. If the motor speed is less than or equal to the value set in b2-01, then the drive will do Zero Speed Control for the time set in b2-04.

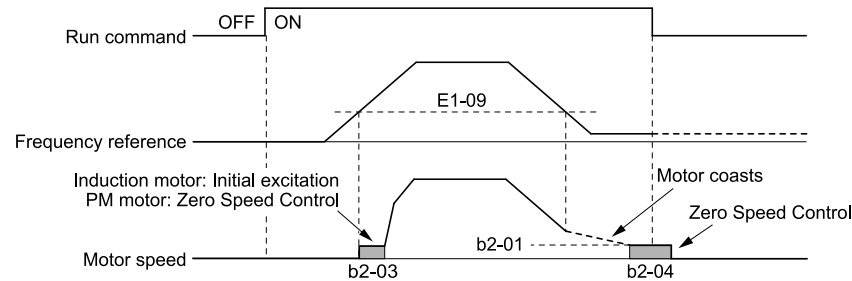


Figure 2.19 Coast to Stop

**2 : Operate at Minimum Frequency**

The drive operates the motor at the minimum frequency reference set in *E1-09* when the frequency reference falls below the value set in *E1-09* and the Run command is still enabled.

The drive decelerates the motor when the Stop command is entered (or when the Run command is switched OFF). If the motor speed falls below or is equal to the value set in *b2-01*, then the drive will perform Zero Speed Control for the time set in *b2-04*.

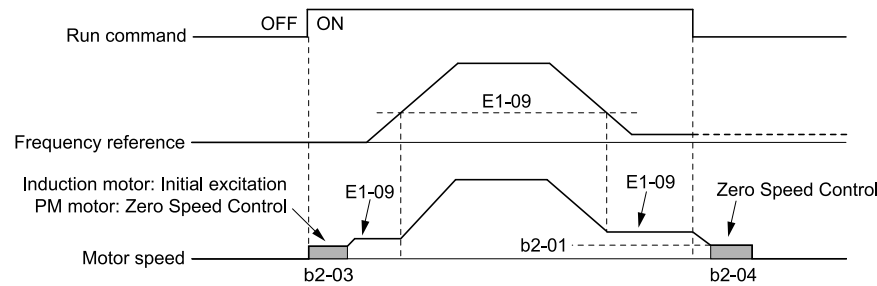


Figure 2.20 Operate at Minimum Frequency

**3 : Operate at Zero Speed**

The drive performs Zero Speed Control when the frequency reference falls below the value set in *E1-09*.

The drive performs Zero Speed Control again for the time set in *b2-04* when the Stop command is entered (or when the Run command is switched OFF).

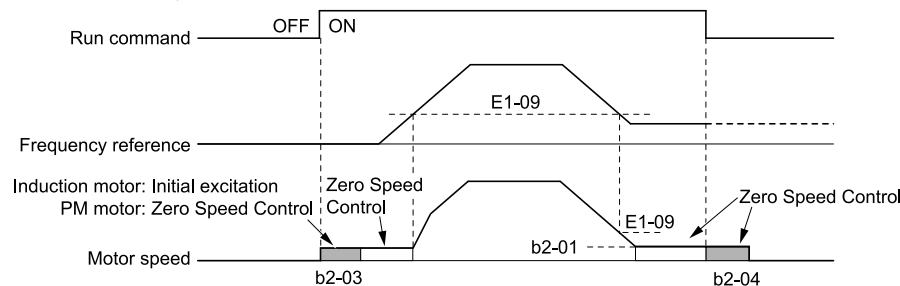


Figure 2.21 Operate at Zero Speed

**■ b1-06: Digital Input Reading**

| No. (Hex.)   | Name                  | Description   | Default (Range) |
|--------------|-----------------------|---|-----------------|
| b1-06 (0185) | Digital Input Reading | <input type="checkbox"/> Vf <input type="checkbox"/> CL-Vf <input type="checkbox"/> OLV <input type="checkbox"/> CLV <input type="checkbox"/> AOLV <input type="checkbox"/> OLV/PM <input type="checkbox"/> AOLV/PM <input type="checkbox"/> CLV/PM <input type="checkbox"/> EZOLV<br>Sets the number of times that the drive reads the sequence input command to prevent malfunction due to noise. | 1 (0, 1)        |

**0 : Single Scan**

The drive reads the terminal status one time. The drive immediately reads all changes to the terminal status.

This setting lets the drive quickly respond to changes in the sequence, but noise can cause malfunction.

**1 : Double Scan**

Parameter Details

## 2.3 b: Application

The drive reads the terminal status two times. The drive reads all changes to the terminal status twice to make sure that the reading is the same.

The drive responds more slowly than when it reads the sequence one time, but this setting prevents malfunction due to noise.

### ■ b1-07: LOCAL/REMOTE Run Selection

| No. (Hex.)      | Name                       | Description   | Default (Range) |
|-----------------|----------------------------|---|-----------------|
| b1-07<br>(0186) | LOCAL/REMOTE Run Selection | <div style="display: flex; justify-content: space-between; align-items: center;"> <span>V/f</span> <span>CL-V/f</span> <span>OLV</span> <span>CLV</span> <span>AOLV</span> <span>OLV/PM</span> <span>AOLV/PM</span> <span>CLV/PM</span> <span>EZOLV</span> </div> <p>Sets drive response to an existing Run command when the drive receives a second Run command from a different location.</p> | 0<br>(0, 1)     |

This parameter interlocks the drive to help prevent accidents that can occur if the motor starts to rotate because the Run command source changed.

To switch the RUN command source, push **LO/RE** on the keypad or set  $H1-xx = 1, 2$  [*MFDI Function Select = LOCAL/REMOTE Selection, External Reference 1/2 Selection*] and turn the terminal ON/OFF.

#### 0 : Disregard Existing RUN Command

If a Run command is enabled when you switch between Run command sources, the drive will not operate the motor. When the drive is operating the motor, turn OFF the Run command to stop the motor. Enter the Run command again to start operation.

#### 1 : Accept Existing RUN Command

If a Run command is enabled when you switch between Run command sources, the drive will start to operate the motor or continue to operate the motor.

**WARNING! Sudden Movement Hazard.** When you use a 3-Wire sequence, set  $A1-03 = 3330$  [*Initialize Parameters = 3-Wire Initialization*] and make sure that  $b1-17 = 0$  [*Run Command at Power Up = Disregard Existing RUN Command*] (default). If you do not correctly set the drive parameters for 3-Wire operation before you energize the drive, the motor can suddenly rotate in reverse when you energize the drive.

### ■ b1-08: Run Command Select in PRG Mode

| No. (Hex.)      | Name                           | Description   | Default (Range) |
|-----------------|--------------------------------|---|-----------------|
| b1-08<br>(0187) | Run Command Select in PRG Mode | <div style="display: flex; justify-content: space-between; align-items: center;"> <span>V/f</span> <span>CL-V/f</span> <span>OLV</span> <span>CLV</span> <span>AOLV</span> <span>OLV/PM</span> <span>AOLV/PM</span> <span>CLV/PM</span> <span>EZOLV</span> </div> <p>Sets the conditions for the drive to accept a Run command entered from an external source when using the keypad to set parameters.</p> | 0<br>(0 - 2)    |

As a safety precaution, when the drive is in Programming Mode, it will not respond to a Run command.

This parameter helps prevent accidents that can occur if the motor starts to rotate because the drive received a Run command from an external source while the user is programming the drive. You can also set the drive to not show the Programming Mode when a Run command is active.

#### Note:

Refer to this table for Drive Mode and Programming Mode functions.

| Mode             | Keypad Screen                 | Function                                     |
|------------------|-------------------------------|--|
| Drive Mode       | Monitors                      | Sets monitor display.                        |
| Programming Mode | Parameters                    | Changes parameter settings.                  |
|                  | User Custom Parameters        | Shows the User Parameters.                   |
|                  | Parameter Backup/Restore      | Saves parameters to the keypad as backup.    |
|                  | Modified Parameters/Fault Log | Shows modified parameters and fault history. |
|                  | Auto-Tuning                   | Auto-Tunes the drive.                        |
|                  | Initial Setup                 | Changes initial settings.                    |
|                  | Diagnostic Tools              | Sets data logs and backlight.                |

#### 0 : Disregard RUN while Programming

The drive rejects the Run command while in Programming Mode.



### 1 : Accept RUN while Programming

The drive accepts a Run command entered from an external source while in Programming Mode.

### 2 : Allow Programming Only at Stop

The drive does not let the user enter Programming Mode when the drive is operating. The drive does not show the Programming Mode when a Run command is active.

### ■ b1-09: L/R Switching during Operation

| No. (Hex.)                | Name                           | Description   | Default (Range) |
|---------------------------|--------------------------------|---|-----------------|
| b1-09<br>(0188)<br>Expert | L/R Switching during Operation | <p>Sets the function that lets the drive switch between LOCAL and REMOTE Modes using  during operation.</p> | 0<br>(0, 1)     |

0 : No

1 : Yes

When you switch the operation mode from REMOTE to LOCAL during run, the drive writes the following REMOTE operation status to the keypad.

- Frequency reference during run
- RUN/STOP status of the keypad
- FWD/REV
- JOG

**Note:**

If b1-09 = 1 and you set either of the following, the drive detects *oPE05 [Run Cmd/Freq Ref Source Sel Err]*.

- b1-02 = 0 [Run Command Selection 1 = Keypad]
- b1-16 = 0 [Run Command Selection 2 = Keypad] and H1-xx = 2 [MFDI Function Select = External Reference 1/2 Selection]
- H1-xx = 3 to 6, 12, 13, 32 [Multi-Step Speed Reference 1 to 4, Jog Reference Selection, FJOG Command, RJOG Command]

### ■ b1-14: Phase Order Selection

| No. (Hex.)      | Name                  | Description  | Default (Range) |
|-----------------|-----------------------|--|-----------------|
| b1-14<br>(01C3) | Phase Order Selection | <p>Sets the phase order for output terminals U/T1, V/T2, and W/T3. This parameter can align the Forward Run command from the drive and the forward direction of the motor without changing wiring.</p> | 0<br>(0, 1)     |

0 : Standard

1 : Switch Phase Order

### ■ b1-15: Frequency Reference Selection 2

| No. (Hex.)      | Name                            | Description   | Default (Range) |
|-----------------|---------------------------------|---|-----------------|
| b1-15<br>(01C4) | Frequency Reference Selection 2 | <p>Sets the input method for frequency reference 2.</p> | 0<br>(0 - 4)    |

This parameter is enabled when *H1-xx = 2 [MFDI Function Selection = External Reference 1/2 Selection]* is activated.



**Note:**

- Push on the keypad to set the input mode to LOCAL and enter the frequency reference from the keypad.
- When the drive receives a Run command when the frequency reference is 0 Hz or less than or equal to the *E1-09 [Minimum Output Frequency]* value, the on the keypad will flash. Check the setting for the frequency reference input and enter a value more than or equal to the *E1-09* value.

0 : Keypad

Use the keypad to enter the frequency reference.

## 2.3 b: Application

Use  and  on the keypad to change the frequency reference.

### 1 : Digital Input

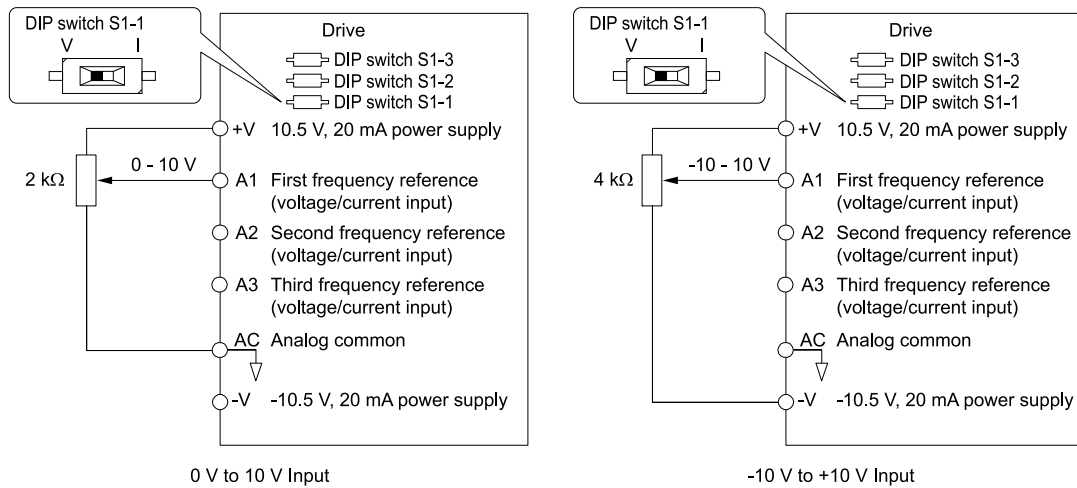
Use MFAI terminals A1, A2, and A3 to input an analog frequency reference with a voltage or current input signal.

- Voltage Input

Refer to Table 2.20 to use a voltage signal input to one of the MFAI terminals.

**Table 2.20 Frequency Reference Voltage Input**

| Terminal | Terminal Signal Level | Parameter Settings     |                               |       |       | Note   |
|----------|-----------------------|------------------------|-------------------------------|-------|-------|--|
|          |                       | Signal Level Selection | Function Selection            | Gain  | Bias  |  |
| A1       | 0 - 10 V              | H3-01 = 0              | H3-02 = 0<br>[Frequency Bias] | H3-03 | H3-04 | Set DIP switch S1-1 to "V" for voltage input.  |
|          | -10 - +10 V           | H3-01 = 1              |                               |       |       |  |
| A2       | 0 - 10 V              | H3-09 = 0              | H3-10 = 0<br>[Frequency Bias] | H3-11 | H3-12 | Set DIP switch S1-2 to "V" for voltage input.  |
|          | -10 - +10 V           | H3-09 = 1              |                               |       |       |  |
| A3       | 0 - 10 V              | H3-05 = 0              | H3-06 = 0<br>[Frequency Bias] | H3-07 | H3-08 | Set DIP switch S1-3 to "V" for voltage input.<br>Set DIP switch S4 to "AI" for analog input. |
|          | -10 - +10 V           | H3-05 = 1              |                               |       |       |  |



**Figure 2.22 Example of Setting the Frequency Reference with a Voltage Signal to Terminal A1**

**Note:**

You can also use this diagram to wire terminals A2 and A3.

- Current Input

Refer to Table 2.21 to use a voltage signal input to one of the MFAI terminals.

**Table 2.21 Frequency Reference Current Input**

| Terminal | Signal Level  | Parameter Settings     |                               |       |       | Note   |
|----------|---------------|------------------------|-------------------------------|-------|-------|--|
|          |               | Signal Level Selection | Function Selection            | Gain  | Bias  |  |
| A1       | 4 mA to 20 mA | H3-01 = 2              | H3-02 = 0<br>[Frequency Bias] | H3-03 | H3-04 | Set DIP switch S1-1 to "I" for current input.  |
|          | 0 - 20 mA     | H3-01 = 3              |                               |       |       |  |
| A2       | 4 mA to 20 mA | H3-09 = 2              | H3-10 = 0<br>[Frequency Bias] | H3-11 | H3-12 | Set DIP switch S1-2 to "I" for current input.  |
|          | 0 - 20 mA     | H3-09 = 3              |                               |       |       |  |
| A3       | 4 mA to 20 mA | H3-05 = 2              | H3-06 = 0<br>[Frequency Bias] | H3-07 | H3-08 | Set DIP switch S1-3 to "I" for current input.<br>Set DIP switch S4 to "AI" for analog input. |
|          | 0 - 20 mA     | H3-05 = 3              |                               |       |       |  |

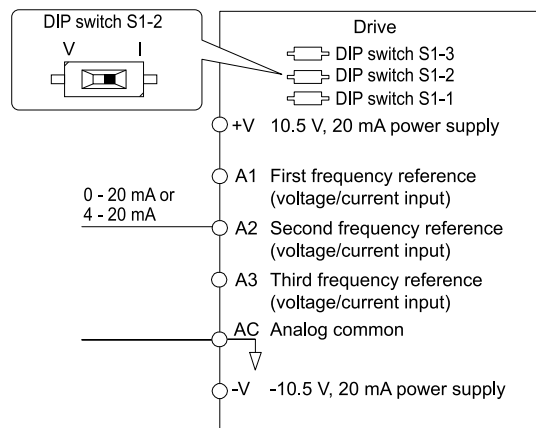


Figure 2.23 Example of Setting the Frequency Reference with a Current Signal to Terminal A2

**Note:**

You can also use this diagram to wire terminals A1 and A3.

### Changing between Master and Auxiliary Frequency References

Use the multi-step speed reference function to change the frequency reference input between terminals A1, A2, and A3.

## 2 : Memobus/Modbus Communications

Use MEMOBUS/Modbus communications to enter the frequency reference.

## 3 : Option PCB

Use a communications option card or input option card connected to the drive to enter the Run command.

Refer to the instruction manual included with the option card to install and set the option card.

**Note:**

If  $b1-15 = 3$  but no option card is connected, then  $oPE03$  [Multi-Function Input Setting Err] will flash on the keypad.

## 4 : Pulse Train Input

Use a pulse train signal from the pulse train input terminal RP to enter the frequency reference.

Do this procedure to make sure that the pulse train signal is operating correctly.

1. Set  $b1-15 = 4$ ,  $H6-01 = 0$  [Terminal RP Pulse Train Function = Frequency Reference].
2. Set  $H6-02$  [Terminal RP Frequency Scaling] to the number of pulses that determine 100% of the frequency reference.
3. The terminal assigned to  $H1-xx = 2$  [MFDI Function Selection = External Reference 1/2 Selection] is turned ON.
4. Enter a pulse train signal on the terminal RP and make sure that the keypad shows a correct frequency reference.

## ■ b1-16: Run Command Selection 2

| No. (Hex.)   | Name                    | Description  | Default (Range) |
|--------------|-------------------------|--|-----------------|
| b1-16 (01C5) | Run Command Selection 2 | <div style="display: flex; gap: 5px;"> <span>V/f</span> <span>CL-V/f</span> <span>OLV</span> <span>CLV</span> <span>AOLV</span> <span>OLV/PM</span> <span>AOLV/PM</span> <span>CLV/PM</span> <span>EZOLV</span> </div> Sets the input method for Run Command 2 when the user switches the control circuit terminals ON/OFF to change the Run command source. | 0 (0 - 3)       |


This parameter is enabled when  $H1-xx = 2$  [MFDI Function Select = External Reference 1/2 Selection] is activated.

## 0 : Keypad

Use the keypad to enter the Run command.

You can use the JOG operation or the FWD/REV commands from the keypad.

**Note:**

The keypad's  is lit while the keypad is the Run command source.

## 1 : Digital Input

## 2.3 b: Application

Use the control circuit terminals to enter the Run command. Select the input method for the Run command with an *H1-xx* parameter.

Set *H1-xx* = 0, 40 to 43 [*3-Wire Sequence, Run Command (2-Wire Sequence)*]. The default setting is 2-wire sequence 1.

- 2-wire Sequence 1  
This sequence has two input types: FWD/Stop and REV/Stop. Set *A1-03* = 2220 [*Initialize Parameters = 2-Wire Initialization*] to initialize the drive and set terminals S1 and S2 for a 2-wire sequence.
- 2-wire Sequence 2  
This sequence has two input types: Run/Stop and FWD/REV.
- 3-Wire Sequence  
This sequence has three input types: Run, Stop, and FWD/REV. Set *A1-03* = 3330 [*Initialize Parameters = 3-Wire Initialization*] to initialize the drive and set terminals S1, S2, and S5 for a 3-wire sequence.

### 2 : Memobus/Modbus Communications

Use MEMOBUS/Modbus communications to enter the Run command.

### 3 : Option PCB


Use a communications option card or input option card connected to the drive to enter the Run command.

Refer to the instruction manual included with the option card to install and set the option card.

**Note:**

If *b1-16* = 3 but no option card is connected, then *oPE03* [*Multi-Function Input Setting Err*] will flash on the keypad.

### ■ b1-17: Run Command at Power Up


| No. (Hex.)      | Name                    | Description   | Default (Range) |
|-----------------|-------------------------|---|-----------------|
| b1-17<br>(01C6) | Run Command at Power Up | <br>Sets drive response when energizing a drive that has an external Run command. Set this parameter in applications where energizing or de-energizing the drive enables the Run command. | 0<br>(0, 1)     |

### 0 : Disregard Existing RUN Command

The drive does not start to operate the application when the power is switched ON, even when there is an existing Run command.

Enter the Run command again to operate the application.

**Note:**


When you energize the drive,  on the keypad will flash quickly if the Run command is already enabled from an external source.

### 1 : Enable

When there is an existing Run command, the drive starts to operate the application when the power is switched ON.

**WARNING! Sudden Movement Hazard.** When you use a 3-Wire sequence, set *A1-03* = 3330 [*Initialize Parameters = 3-Wire Initialization*] and make sure that *b1-17* = 0 [*Run Command at Power Up = Disregard Existing RUN Command*] (default). If you do not correctly set the drive parameters for 3-Wire operation before you energize the drive, the motor can suddenly rotate in reverse when you energize the drive.

### ■ b1-21: CLV Start Selection

| No. (Hex.)                | Name                | Description   | Default (Range) |
|---------------------------|---------------------|---|-----------------|
| b1-21<br>(0748)<br>Expert | CLV Start Selection | <br>Sets the conditions for the drive to accept a Run command if <i>A1-02</i> = 3, 7 [ <i>Control Method Selection = CLV, CLV/PM</i> ]. Usually it is not necessary to change this setting. | 0<br>(0, 1)     |

### 0 : Reject RUN Command

When motor speed  $\geq b2-01$  or motor speed  $< E1-09$ , the drive will not accept a Run command.

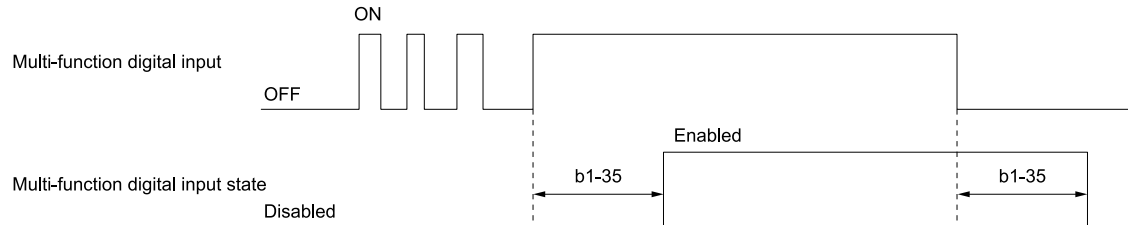
### 1 : Accept RUN Command

When motor speed  $\geq b2-01$  or motor speed  $< E1-09$ , the drive will accept a Run command.

### ■ b1-35: Digital Input Deadband Time

| No. (Hex.)                | Name                        | Description   | Default (Range)             |
|---------------------------|-----------------------------|---|-----------------------------|
| b1-35<br>(1117)<br>Expert | Digital Input Deadband Time | <span>V/f</span> <span>CL-V/f</span> <span>OLV</span> <span>CLV</span> <span>AOLV</span> <span>OLV/PM</span> <span>AOLV/PM</span> <span>CLV/PM</span> <span>EZOLV</span><br>Sets the deadband time for MFDIs. | 0.0 ms<br>(0.0 to 100.0 ms) |

When the on/off time for MFDIs is longer than the time set in *b1-35*, the drive activates the MFDI. Set this parameter to prevent malfunctions caused by relay chattering for applications in which relays send input to MFDI terminals.



### ◆ b2: DC Injection Braking and Short Circuit Braking

*b2* parameters set the DC Injection Braking and Short Circuit Braking functions.

- DC Injection Braking: A braking method that injects DC current into the motor windings. This function should not be used too frequently, because it generates a fair amount of heat in the motor.
- Short Circuit Braking: A braking method for PM motors.

#### ■ b2-01: DC Injection/Zero SpeedThreshold

| No. (Hex.)      | Name                             | Description  | Default (Range)                        |
|-----------------|----------------------------------|--|--|
| b2-01<br>(0189) | DC Injection/Zero SpeedThreshold | <span>V/f</span> <span>CL-V/f</span> <span>OLV</span> <span>CLV</span> <span>AOLV</span> <span>OLV/PM</span> <span>AOLV/PM</span> <span>CLV/PM</span> <span>EZOLV</span><br>Sets the frequency to start DC Injection Braking, Short Circuit Braking, and Zero Servo. | Determined by A1-02<br>(0.0 - 10.0 Hz) |

**Note:**

This parameter is available when *b1-03* = 0 [Stopping Method Selection = Ramp to Stop].

When the control method selected in *A1-02* [Control Method Selection] changes, the *b2-01* function changes.

## 2.3 b: Application

| Parameter Settings  | Function of b2-01  |
|---|--|
| <p><i>A1-02 = 0, 1, 2 [ V/f, CL-V/f, OLV ]</i></p> <p><i>A1-02 = 4 [AOLV] and n4-72 = 0 [Speed Feedback Mode = Without Encoder]</i></p> | <p>b2-01 sets the frequency to start DC Injection Braking at stop. When the output frequency is less than or equal to the value set in b2-01, the drive will inject the quantity of DC current set in b2-02 [DC Injection Braking Current] into the motor for the time set in b2-04 [DC Inject Braking Time at Stop].</p> <p><b>Figure 2.24 DC Injection Braking at Stop</b></p> <p><b>Note:</b><br/>When <math>b2-01 \leq E1-09</math> [Minimum Output Frequency], the drive will start DC Injection Braking from the frequency set in E1-09.</p>   |
| <p><i>A1-02 = 5, 6, 8 [OLV/PM, AOLV/PM, EZOLV]</i></p>  | <p>b2-01 sets the frequency to start Short Circuit Braking at stop. When the output frequency is less than or equal to the value set in b2-01, the drive will do Short Circuit Braking for the time set in b2-13 [Short Circuit Brake Time @ Stop]. When b2-04 &gt; 0.00 s, the drive will complete Short Circuit Braking, then do DC Injection Braking for the time set in b2-04.</p> <p><b>Figure 2.25 Short Circuit Braking at Stop</b></p> <p><b>Note:</b><br/>When <math>b2-01 \leq E1-09</math>, the drive will start Short Circuit Braking from the frequency set in E1-09. If b2-01 and E1-09 = 0 Hz, the drive will not do Short Circuit Braking.</p> |
| <p><i>A1-02 = 3, 7 [CLV, CLV/PM]</i></p> <p><i>A1-02 = 4 [AOLV] and n4-72 = 1 [With Encoder]</i></p>                                    | <p>b2-01 sets the frequency to start Zero Speed Control at stop. When the output frequency is less than or equal to the value set in b2-01, the drive will do Zero Speed Control for the time set in b2-04.</p> <p><b>Figure 2.26 Zero Speed Control at Stop</b></p> <p><b>Note:</b><br/>When <math>b2-01 \leq E1-09</math>, the drive will start Zero Speed Control from the frequency set in E1-09.</p>  |

### ■ b2-02: DC Injection Braking Current

| No. (Hex.)   | Name                         | Description   | Default (Range) |
|--------------|------------------------------|---|-----------------|
| b2-02 (018A) | DC Injection Braking Current | <p>V/f CL-V/f OLV CLV AOLV OLV/PM AOLV/PM CLV/PM EZOLV</p> <p>Sets the DC Injection Braking current as a percentage of the drive rated current.</p> | 50% (0 - 100%)  |

When the DC Injection Braking current is more than 50%, the drive decreases the carrier frequency to 1 kHz. The motor rated current determines how much DC Injection Braking current that the drive can use.

The DC Injection Braking current level has an effect on the strength of the magnetic field that locks the motor shaft. As the current level increases, the motor windings will supply more heat. Do not set this parameter higher than the level that is necessary to hold the motor shaft.

**Note:**

When  $A1-02 = 4$  [Control Method Selection = AOLV] and  $n4-72 = 1$  [Speed Feedback Mode = With Encoder], the drive ignores the b2-02 setting and does initial excitation.

### ■ b2-03: DC Inject Braking Time at Start

| No. (Hex.)   | Name                            | Description   | Default (Range)   |
|--------------|---------------------------------|---|---|
| b2-03 (018B) | DC Inject Braking Time at Start | <p>V/f CL-V/f OLV CLV AOLV OLV/PM AOLV/PM CLV/PM EZOLV</p> <p>Sets the DC Injection Braking Time at stop. Sets the time of Zero Speed Control at start if <math>A1-02 = 3, 7</math> [Control Method Selection = CLV, CLV/PM].</p> | <p>A1-02 = 4: 0.03 s</p> <p>Other than A1-02 = 4: 0.00 s (0.00 - 10.00 s)</p> |

This function stops then restarts a coasting motor and increases motor flux to make high starting torque (a process called initial excitation). Set this parameter to 0.00 to disable the function.

**Note:**

- To restart a coasting motor, use DC Injection Braking to stop and then restart the motor, or enable Speed Search. If you do not enable DC Injection Braking or Speed Search *ov* [Overvoltage] and *oC* [Overcurrent] faults may occur.
- Sets the time of Zero Speed Control at start if  $A1-02 = 4$  [AOLV] and  $n4-72 = 1$  [Speed Feedback Mode = With Encoder].

### ■ b2-04: DC Inject Braking Time at Stop

| No. (Hex.)   | Name                           | Description  | Default (Range)                      |
|--------------|--------------------------------|--|--------------------------------------|
| b2-04 (018C) | DC Inject Braking Time at Stop | <div style="display: flex; justify-content: space-between; font-size: small;"> <span>V/f</span> <span>CL-V/f</span> <span>OLV</span> <span>CLV</span> <span>AOLV</span> <span>OLV/PM</span> <span>AOLV/PM</span> <span>CLV/PM</span> <span>EZOLV</span> </div> Sets the DC Injection Braking Time at stop. Sets the time of Zero Speed Control at stop if $A1-02 = 3, 7$ [Control Method Selection = CLV, CLV/PM]. | Determined by A1-02 (0.00 - 10.00 s) |

This function fully stops a motor with a large inertia during deceleration and will not let the inertia continue to rotate the motor.

Set this parameter to 0.00 to disable the function.

When a longer time is required to stop the motor, increase the value.

**Note:**

- Sets the time of Zero Speed Control at stop if  $A1-02 = 4$  [AOLV] and  $n4-72 = 1$  [Speed Feedback Mode = With Encoder].

### ■ b2-08: Magnetic Flux Compensation Value

| No. (Hex.)   | Name                             | Description   | Default (Range) |
|--------------|----------------------------------|---|-----------------|
| b2-08 (0190) | Magnetic Flux Compensation Value | <div style="display: flex; justify-content: space-between; font-size: small;"> <span>V/f</span> <span>CL-V/f</span> <span>OLV</span> <span>CLV</span> <span>AOLV</span> <span>OLV/PM</span> <span>AOLV/PM</span> <span>CLV/PM</span> <span>EZOLV</span> </div> Sets how much current the drive injects when DC Injection Braking at Start starts (Initial Excitation) as a percentage of $E2-03$ [Motor No-Load Current]. | 0% (0 - 1000%)  |

This parameter is effective when you start a high-capacity motor (a motor with a large secondary circuit time constant). This function can quickly increase motor flux to make high starting torque (a process called initial excitation).

The current level for DC Injection Braking at start changes linearly from the setting of  $b2-08$  to the setting of  $b2-03$  as shown in Figure 2.27.

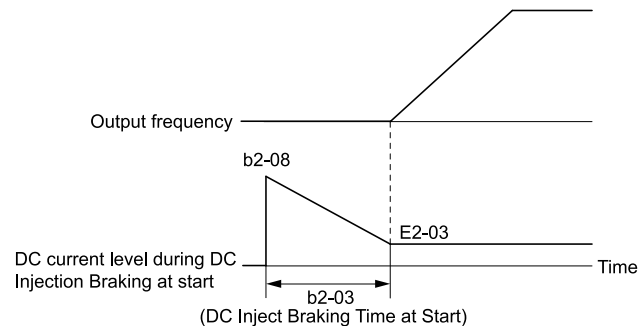


Figure 2.27 DC Current Level during DC Injection Braking at Start

**Note:**

- If  $b2-08 < 100\%$ , flux will develop very slowly.
- When  $b2-08 = 0\%$ , the DC current level will be the DC Injection current set in  $b2-02$  [DC Injection Braking Current].
- DC Injection Braking at start may generate a fair amount of noise if  $b2-08$  is set too high. Adjust  $b2-08$  to decrease the volume to the permitted level.

### ■ b2-12: Short Circuit Brake Time @ Start

| No. (Hex.)   | Name                             | Description  | Default (Range)         |
|--------------|----------------------------------|--|-------------------------|
| b2-12 (01BA) | Short Circuit Brake Time @ Start | <div style="display: flex; justify-content: space-between; font-size: small;"> <span>V/f</span> <span>CL-V/f</span> <span>OLV</span> <span>CLV</span> <span>AOLV</span> <span>OLV/PM</span> <span>AOLV/PM</span> <span>CLV/PM</span> <span>EZOLV</span> </div> Sets the Short Circuit Braking time at start. | 0.00 s (0.00 - 25.50 s) |

## 2.3 b: Application

This function stops and restarts a coasting PM motor. The drive short circuits all the three motor phases to make braking torque in the motor.

Set this parameter to 0.00 to disable the function.

**Note:**

- Short circuit Braking will let external forces rotate the PM motor. Use DC Injection Braking to prevent motor rotation from external forces.
- Motor speed and load conditions can make it necessary to install a dynamic braking option on the drive.

### ■ b2-13: Short Circuit Brake Time @ Stop

| No. (Hex.)   | Name                            | Description   | Default (Range)   |
|--------------|---------------------------------|---|---|
| b2-13 (01BB) | Short Circuit Brake Time @ Stop | V/f CL-V/f OLV CLV AOLV <b>OLV/PM</b> AOLV/PM CLV/PM <b>EZOLV</b><br>Sets the Short Circuit Braking time at stop. | A1-02 = 8: 0.00 s<br>Other than A1-02 = 8: 0.50 s<br>(0.00 - 25.50 s) |

This function fully stops a PM motor with a large inertia during deceleration and will not let the inertia continue to rotate the motor.

Short Circuit Braking operates for the time set in *b2-13* when output frequency is less than the value set in *b2-01* [DC Injection/Zero SpeedThreshold] or *E1-09* [Minimum Output Frequency].

Set this parameter to 0.00 to disable the function.

**Note:**

Motor speed and load conditions can make it necessary to install a dynamic braking option on the drive.

### ■ b2-18: Short Circuit Braking Current

| No. (Hex.)   | Name                          | Description   | Default (Range)          |
|--------------|-------------------------------|---|--------------------------|
| b2-18 (0177) | Short Circuit Braking Current | V/f CL-V/f OLV CLV AOLV <b>OLV/PM</b> AOLV/PM CLV/PM <b>EZOLV</b><br>Sets the Short Circuit Braking Current as a percentage of the motor rated current. | 100.0%<br>(0.0 - 200.0%) |

The Short Circuit Braking current cannot be higher than the drive rated current, although a higher current level can be set using *b2-18*. The maximum rated current is 120% when the drive is set for Normal Duty (*C6-01* = 1 [Normal Duty Rating]). The maximum rated current is 150% when the drive is set for Heavy Duty (*C6-01* = 0 [Heavy Duty Rating]).

## ◆ b3: Speed Search

The Speed Search function detects the actual speed of a coasting motor, then restarts the motor before the motor stops. Use Speed Search in these conditions:

- To continue operation after momentary power loss
- To switch from commercial power supply to drive power
- To restart a coasting fan

For example, the drive output turns off and the motor coasts when there is a momentary loss of power. After you return power, the drive does Speed Search on the coasting motor, and restarts the motor from the detected speed.

When you use a PM motor, enable *b3-01* [Speed Search at Start Selection].

There are two types of Speed Search for induction motors: Current Detection and Speed Estimation. Use parameter *b3-24* [Speed Search Method Selection] to select the type of Speed Search.

Parameter settings are different for different types of Speed Search. For details, refer to Table 2.22.

**Table 2.22 Speed Search and Related Parameters**

| Parameter                               | Speed Estimation | Current Detection 2 |
|---|------------------|---------------------|
|   | b3-24 = 1        | b3-24 = 2           |
| b3-01 [Speed Search at Start Selection] | x                | x                   |
| b3-03 [Speed Search Deceleration Time]  | -                | x                   |
| b3-05 [Speed Search Delay Time]         | x                | x                   |



| Parameter                                | Speed Estimation | Current Detection 2 |
|--|------------------|---------------------|
|  | b3-24 = 1        | b3-24 = 2           |
| b3-06 [Speed Estimation Current Level 1] | x                | -                   |
| b3-07 [Speed Estimation Current Level 2] | x                | -                   |
| b3-08 [Speed Estimation ACR P Gain]      | x                | -                   |
| b3-09 [Speed Estimation ACR I Time]      | x                | -                   |
| b3-10 [Speed Estimation Detection Gain]  | x                | -                   |
| b3-14 [Bi-directional Speed Search]      | x                | o *1                |
| b3-17 [Speed Est Retry Current Level]    | x                | x                   |
| b3-18 [Speed Est Retry Detection Time]   | x                | x                   |
| b3-19 [Speed Search Restart Attempts]    | x                | x                   |
| b3-24 [Speed Search Method Selection]    | x (1)            | x (2)               |
| b3-25 [Speed Search Wait Time]           | x                | x                   |
| b3-26 [Direction Determination Level]    | x                | -                   |
| b3-27 [Speed Search RUN/BB Priority]     | x                | x                   |
| b3-29 [Speed Search Back-EMF Threshold]  | -                | -                   |
| b3-31 [Spd Search Current Reference Lvl] | -                | x                   |
| b3-32 [Spd Search Current Complete Lvl]  | -                | x                   |
| b3-33 [Speed Search during Uv Selection] | x                | x                   |
| b3-35 [Low Back EMF Detection Level]     | x                | x                   |
| b3-36 [High Back EMF Detection Level]    | x                | x                   |
| b3-54 [Search Time]                      | -                | -                   |
| b3-55 [Current Increment Time]           | -                | -                   |
| b3-56 [InverseRotationSearch WaitTime]   | -                | x                   |

\*1 Available if the drive software version is PRG:1023 or later. If the drive software version is PRG:1022 or earlier and  $b3-24 = 2$  [Speed Search Method Selection = Current Detection 2], the setting  $b3-14 = 1$  has no effect on the drive operation. You can check the software version in the "PRG" field printed on the nameplate on the right side of the drive or by using U1-25 [SoftwareNumber Flash].

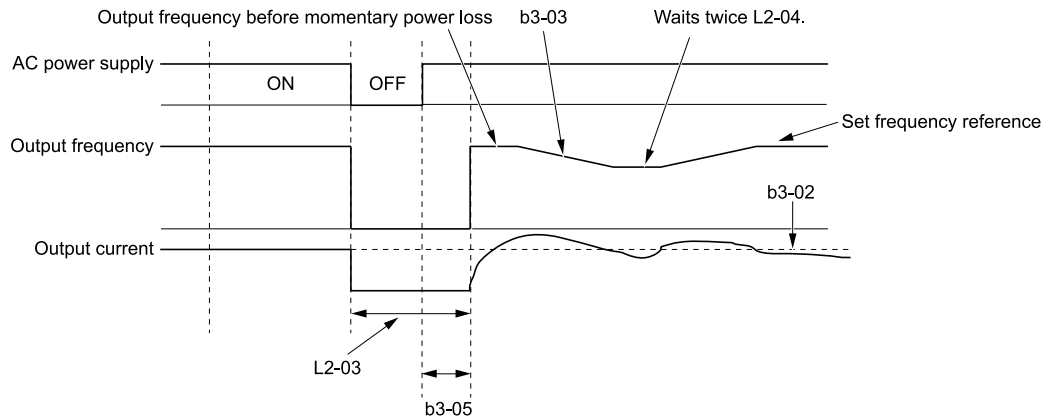
**Note:**

- To use Speed Estimation Speed Search with V/f Control, do Rotational Auto-Tuning before you set the Speed Search function. If the wire length between the drive and motor changed since the last time you did Auto-Tuning, do Stationary Auto-Tuning for Line-to-Line Resistance process again.
- If  $A1-02 = 5, 6$  [PM Open Loop Vector; PM Advanced Open Loop Vector] and the wiring distance between the motor and drive is long or if the motor is coasting at more than or equal to 200 Hz, do not use Speed Search to restart the motor. Use Short Circuit Braking.

## ■ Current Detection 2

Use this Speed Search function with induction motors. Set  $b3-24 = 2$  [Speed Search Method Selection = Current Detection 2]. Current Detection Speed Search injects current into the motor to detect the speed of an induction motor. Speed Search increases the output voltage for the time set in L2-04 [Powerloss V/f Recovery Ramp Time], starting from the maximum output frequency or the frequency reference.

## 2.3 b: Application

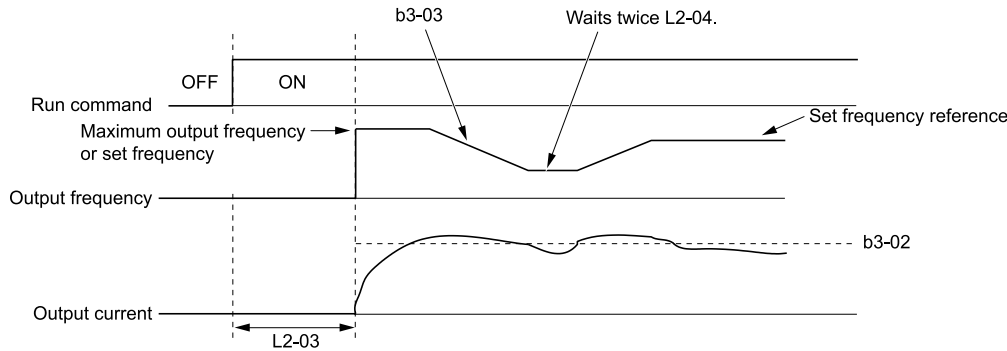


**Figure 2.28 Current Detection 2 after a momentary power loss**

**Note:**

Once power is restored, the drive will not execute Speed Search until the time set in *b3-05* [Speed Search Delay Time] has passed. Thus, the drive will not always start Speed Search although the time set in *L2-03* [Minimum Baseblock Time] is expired.

If you enter the Run command at the same time as Speed Search, the drive will not do Speed Search until the time set in *L2-03* is expired. If the value set in *L2-03* < *b3-05*, the drive will use the wait time set in *b3-05*.



**Figure 2.29 Speed Search Selection at Start (Current Detection Type)**

**WARNING! Sudden Movement Hazard.** Do not do Current Detection Speed Search with light loads or a stopped motor. If you do Auto-Tuning in these conditions, the motor can suddenly accelerate and cause serious injury or death.

**Note:**

- You cannot use Current Detection Speed Search with PM motors.
- If the motor is rotating in reverse, you cannot do Speed Search.
- If the drive detects *oL1* [Motor Overload] during Current Detection Speed Search, decrease the value set in *b3-03*.
- If the drive detects *oC* [Overcurrent] or *ov* [Overvoltage] during Current Detection Speed Search after the drive recovers from a momentary power loss, increase the value set in *L2-03*.

### ■ Speed Estimation

Use this Speed Search function with induction motors. Set *b3-24* = 1 [Speed Search Method Selection = Speed Estimation]. This function uses less current and has a shorter search time than other functions. This function lets you do Speed Search when the motor is rotating in reverse. When you return power after a power loss, the motor will not suddenly accelerate.

**Note:**

You cannot do Speed Estimation Speed Search in these conditions:

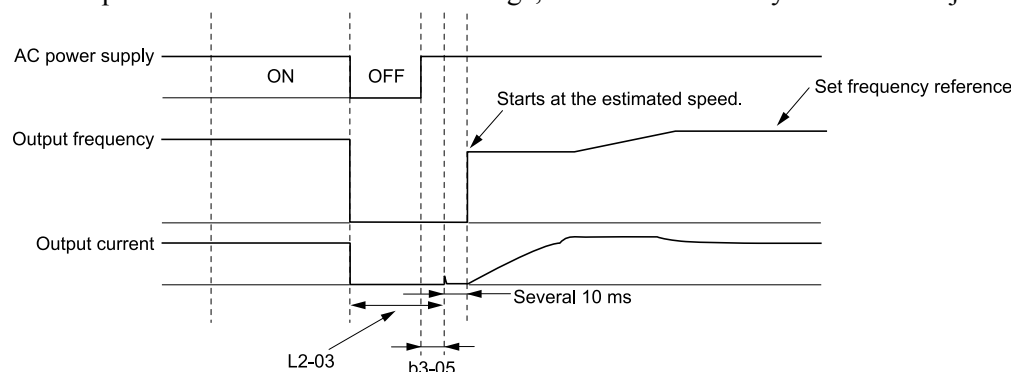
- When you operate more than one motor with one drive
- When you use a high-speed motor (200 Hz or higher)
- When you use a 1.5 kW or smaller motor.
- When the motor output is more than 1 frame size smaller than the drive capacity
- When there is a long wiring distance between the drive and motor

For these conditions, use Current Detection Speed Search.

Speed Estimation Speed Search uses these two steps to estimate the motor speed:

### 1. Residual Voltage Search

When there is a short baseblock time, the drive searches for residual voltage. The drive uses the residual voltage in the motor to estimate the motor speed and direction of rotation. The drive outputs the estimated motor speed as frequency, then uses the deceleration rate set in *L2-04* to increase the voltage. When the output voltage aligns with the V/f pattern, the drive accelerates or decelerates the motor to the frequency reference. If the drive cannot estimate the motor speed because of low residual voltage, it will automatically do Current Injection.



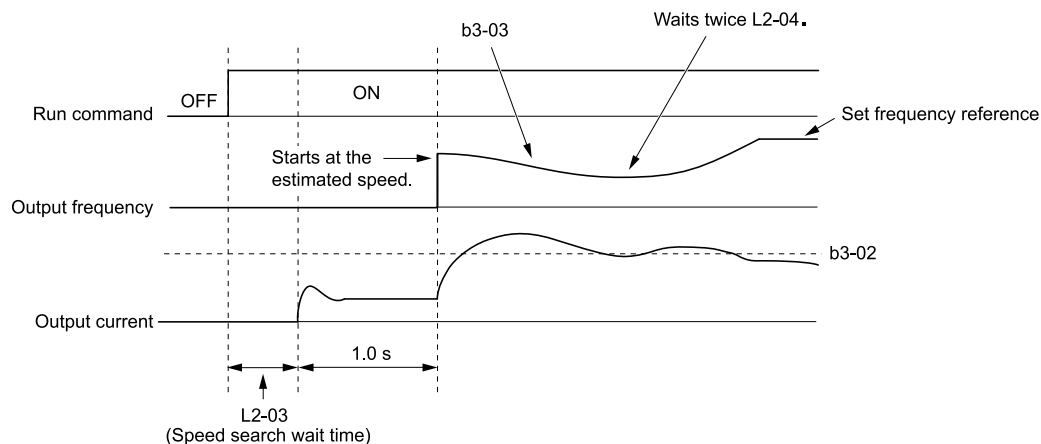
**Figure 2.30 Speed Search after Baseblock**

#### Note:

After you return power, the drive waits for the time set in *b3-05*. If power loss is longer than the time set in *L2-03*, the drive will start Speed Search when the time set in *b3-05* is expired after the power recovery.

### 2. Current Injection

If there is not sufficient residual voltage in the motor, the drive does Current Injection. The drive injects the quantity of DC current set in *b3-06* [Speed Estimation Current Level 1] into the motor windings to estimate the motor speed and direction of rotation. The drive outputs the estimated motor speed as frequency, then uses the deceleration rate set in *L2-04* to increase the voltage. When the output voltage aligns with the V/f pattern, the drive accelerates or decelerates the motor to the frequency reference.



**Figure 2.31 Speed Search Selection at Start**

#### Note:

Set the lower limit of the delay time to *b3-05* for when Speed Search starts.

## ■ Speed Search and Operation Conditions

These conditions apply to Speed Search operation. When *A1-02 = 0, 1, 2* [Control Method Selection = V/f Control, V/f Control with Encoder, Open Loop Vector], set *b3-24* [Speed Search Method Selection] before you do Speed Search.

- Do Speed Search with each Run Command  
The drive ignores a Speed Search command from the external terminals.
- Use an MFDI to do an External Speed Search Command  
To use an MFDI to do Speed Search, input the Run command at the same time that terminal Sx set for Speed Search activates, or after Speed Search activates.

## 2.3 b: Application

Set Speed Search to *H1-xx* to do the function externally. You cannot set external Speed Search 1 and 2 at the same time.

**Table 2.23 Execute Speed Search via the Digital Input Terminals**

| H1-xx Setting | Name                   | Current Detection 2   | Speed Estimation   |
|---------------|------------------------|---|--|
| 61            | Speed Search from Fmax | ON: Speed Search starts from <i>E1-04</i> [Maximum Output Frequency].                                       | External Speed Search commands 1 and 2 work the same.<br>The drive estimates the motor speed, then starts Speed Search from the estimated speed. |
| 62            | Speed Search from Fref | ON: Speed Search starts from the frequency reference immediately before you input the Speed Search command. |  |

- Do Speed Search with Each Auto Restart  
Set *L5-01* [Number of Auto-Restart Attempts] = 1 or more. After there is an Auto Restart fault, the drive automatically does Speed Search.
- Do Speed Search after Momentary Power Loss  
Set *L2-01* = 1, 2 [Power Loss Ride Through Select = Enabled for L2-02 Time, Enabled while CPU Power Active].
- Do Speed Search after You Clear the External Baseblock Command  
After you clear the external baseblock command, enable the Run command, and when the output frequency is higher than the minimum frequency, the drive does Speed Search.

### ■ b3-01: Speed Search at Start Selection

| No. (Hex.)   | Name                            | Description   | Default (Range)            |
|--------------|---------------------------------|---|----------------------------|
| b3-01 (0191) | Speed Search at Start Selection | <input type="checkbox"/> V/f <input type="checkbox"/> CL-V/f <input type="checkbox"/> OLV <input type="checkbox"/> CLV <input type="checkbox"/> AOLV <input type="checkbox"/> OLV/IPM <input type="checkbox"/> AOLV/IPM <input type="checkbox"/> CLV/IPM <input type="checkbox"/> EZOLV<br>Sets the Speed Search at Start function where the drive will perform Speed Search with each Run command. | Determined by A1-02 (0, 1) |

#### 0 : Disabled

Enter a Run command to start to operate the drive at the minimum output frequency.

When the Run command is enabled and the *Speed Search from Fmax or Fref* [*H1-xx* = 61, 62] is input from a multi-function input terminal, the drive will do Speed Search and start to operate the motor.

#### 1 : Enabled

Enter the Run command to do Speed Search. The drive completes Speed Search then starts to operate the motor.

### ■ b3-02: SpeedSearch Deactivation Current

| No. (Hex.)   | Name                             | Description  | Default (Range)                |
|--------------|----------------------------------|--|--------------------------------|
| b3-02 (0192) | SpeedSearch Deactivation Current | <input type="checkbox"/> V/f <input type="checkbox"/> CL-V/f <input type="checkbox"/> OLV <input type="checkbox"/> CLV <input type="checkbox"/> AOLV <input type="checkbox"/> OLV/IPM <input type="checkbox"/> AOLV/IPM <input type="checkbox"/> CLV/IPM <input type="checkbox"/> EZOLV<br>Sets the current level that stops Speed Search as a percentage of the drive rated output current. Usually it is not necessary to change this setting. | Determined by A1-02 (0 - 200%) |

If the drive cannot restart the motor, decrease this setting.

### ■ b3-03: Speed Search Deceleration Time

| No. (Hex.)   | Name                           | Description  | Default (Range)         |
|--------------|--------------------------------|--|-------------------------|
| b3-03 (0193) | Speed Search Deceleration Time | <input type="checkbox"/> V/f <input type="checkbox"/> CL-V/f <input type="checkbox"/> OLV <input type="checkbox"/> CLV <input type="checkbox"/> AOLV <input type="checkbox"/> OLV/IPM <input type="checkbox"/> AOLV/IPM <input type="checkbox"/> CLV/IPM <input type="checkbox"/> EZOLV<br>Sets the deceleration time during Speed Search operation. Set the length of time to decelerate from the maximum output frequency to the minimum output frequency. | 2.0 s<br>(0.1 - 10.0 s) |

This is the output frequency deceleration time used by Current Detection Speed Search and by the Current Injection Method of Speed Estimation Speed Search.

#### Note:

- If *A1-02* = 8 [Control Method Selection = EZOLV], this parameter takes effect only in Expert Mode.
- If the drive detects *oL1* [Motor Overload] during Current Detection Speed Search, decrease the value set in *b3-03*.

### ■ b3-04: V/f Gain during Speed Search

| No. (Hex.)      | Name                         | Description   | Default (Range)                   |
|-----------------|------------------------------|---|-----------------------------------|
| b3-04<br>(0194) | V/f Gain during Speed Search | <div style="display: flex; gap: 5px;"> <span>V/f</span> <span>CL-V/f</span> <span>OLV</span> <span>CLV</span> <span>AOLV</span> <span>OLV/PM</span> <span>AOLV/PM</span> <span>CLV/PM</span> <span>EZOLV</span> </div> <p>Sets the ratio used to reduce the V/f during searches to reduce the output current during speed searches.</p> | Determined by o2-04<br>(10 - 100) |

Use the this formula to calculate the output voltage during Speed Search:

Output voltage during Speed Search = Configured V/f x b3-04

When the current detection search operates correctly, this configuration is not necessary.

### ■ b3-05: Speed Search Delay Time

| No. (Hex.)      | Name                    | Description  | Default (Range)          |
|-----------------|-------------------------|--|--------------------------|
| b3-05<br>(0195) | Speed Search Delay Time | <div style="display: flex; gap: 5px;"> <span>V/f</span> <span>CL-V/f</span> <span>OLV</span> <span>CLV</span> <span>AOLV</span> <span>OLV/PM</span> <span>AOLV/PM</span> <span>CLV/PM</span> <span>EZOLV</span> </div> <p>Sets the Speed Search delay time to activate a magnetic contactor installed between the drive and motor.</p> | 0.2 s<br>(0.0 - 100.0 s) |

When you use a magnetic contactor between the drive and motor, you must close the contactor before the drive will do Speed Search. This parameter sets a delay time to activate the magnetic contactor.

### ■ b3-06: Speed Estimation Current Level 1

| No. (Hex.)                | Name                             | Description   | Default (Range)                    |
|---------------------------|----------------------------------|---|------------------------------------|
| b3-06<br>(0196)<br>Expert | Speed Estimation Current Level 1 | <div style="display: flex; gap: 5px;"> <span>V/f</span> <span>CL-V/f</span> <span>OLV</span> <span>CLV</span> <span>AOLV</span> <span>OLV/PM</span> <span>AOLV/PM</span> <span>CLV/PM</span> <span>EZOLV</span> </div> <p>Sets the level of current that flows to the motor during Speed Estimation Speed Search as a coefficient of the motor rated current. Usually it is not necessary to change this setting.</p> | Determined by o2-04<br>(0.0 - 2.0) |

When the speed estimation value is the minimum output frequency, increase this setting. You can do this when the motor coasts at a high speed while the drive estimates the speed during Speed Estimation Speed Search. The limit of the output current during speed search is automatically the drive rated current.

**Note:**

When the drive cannot accurately estimate the speed after you adjust this parameter, use Current Detection Speed Search.

### ■ b3-07: Speed Estimation Current Level 2

| No. (Hex.)                | Name                             | Description  | Default (Range)    |
|---------------------------|----------------------------------|--|--------------------|
| b3-07<br>(0197)<br>Expert | Speed Estimation Current Level 2 | <div style="display: flex; gap: 5px;"> <span>V/f</span> <span>CL-V/f</span> <span>OLV</span> <span>CLV</span> <span>AOLV</span> <span>OLV/PM</span> <span>AOLV/PM</span> <span>CLV/PM</span> <span>EZOLV</span> </div> <p>Sets the level of current that flows to the motor during Speed Estimation Speed Search as a coefficient of E2-03 [Motor No-Load Current] or E4-03 [Motor 2 Rated No-Load Current]. Usually it is not necessary to change this setting.</p> | 1.0<br>(0.0 - 3.0) |

During Speed Estimation Speed Searches, when the speed estimation value aligns with the minimum output frequency, increase the setting value in 0.1-unit increments. The limit of the output current during speed search is automatically the drive rated current.

### ■ b3-08: Speed Estimation ACR P Gain

| No. (Hex.)      | Name                        | Description  | Default (Range)                                |
|-----------------|-----------------------------|--|--|
| b3-08<br>(0198) | Speed Estimation ACR P Gain | <div style="display: flex; gap: 5px;"> <span>V/f</span> <span>CL-V/f</span> <span>OLV</span> <span>CLV</span> <span>AOLV</span> <span>OLV/PM</span> <span>AOLV/PM</span> <span>CLV/PM</span> <span>EZOLV</span> </div> <p>Sets the proportional gain for the automatic current regulator during Speed Estimation Speed Search. Also adjusts speed search responsiveness. Usually it is not necessary to change this setting.</p> | Determined by A1-02 and o2-04<br>(0.00 - 6.00) |

## 2.3 b: Application

### ■ b3-09: Speed Estimation ACR I Time

| No. (Hex.)      | Name                        | Description  | Default (Range)  |
|-----------------|-----------------------------|--|--|
| b3-09<br>(0199) | Speed Estimation ACR I Time | <b>V/f</b> <b>CL-V/f</b> <b>OLV</b> <b>CLV</b> <b>AOLV</b> <b>OLV/PM</b> <b>AOLV/PM</b> <b>CLV/PM</b> <b>EZOLV</b><br>Sets the integral time for the automatic current regulator during Speed Estimation Speed Search. Also adjusts speed search responsiveness. Usually it is not necessary to change this setting. | Determined by A1-02 if A1-02 ≠ 5<br>20.0 if A1-02 = 5<br>(0.0 - 1000.0 ms) |

### ■ b3-10: Speed Estimation Detection Gain

| No. (Hex.)                | Name                            | Description  | Default (Range)       |
|---------------------------|---------------------------------|--|-----------------------|
| b3-10<br>(019A)<br>Expert | Speed Estimation Detection Gain | <b>V/f</b> <b>CL-V/f</b> <b>OLV</b> <b>CLV</b> <b>AOLV</b> <b>OLV/PM</b> <b>AOLV/PM</b> <b>CLV/PM</b> <b>EZOLV</b><br>Sets the gain to correct estimated frequencies from Speed Estimation Speed Search. | 1.05<br>(1.00 - 1.20) |

If the drive detects *ov* [DC Bus Overvoltage] when you restart the motor, increase the setting value.

### ■ b3-14: Bi-directional Speed Search

| No. (Hex.)      | Name                        | Description   | Default (Range)                         |
|-----------------|-----------------------------|---|---|
| b3-14<br>(019E) | Bi-directional Speed Search | <b>V/f</b> <b>CL-V/f</b> <b>OLV</b> <b>CLV</b> <b>AOLV</b> <b>OLV/PM</b> <b>AOLV/PM</b> <b>CLV/PM</b> <b>EZOLV</b><br>Sets the direction of Speed Search to the direction of the frequency reference or in the motor rotation direction as detected by the drive. | Determined by A1-02 and b3-24<br>(0, 1) |

**Note:**

- Refer to *Parameters that Change from the Default Settings with A1-02 [Control Method Selection]* on page 125 for information on the initial value of b3-14 [Bi-directional Speed Search] that applies when you set the following.
  - A1-02 = 0, 2, 8 [Control Method Selection = V/f, OLV, EZOLV]
  - E9-01 = 0 [Motor Type Selection = Induction (IM)]
  - b3-24 = 1 [Speed Search Method Selection = Speed Estimation Speed Search]
- The initial value of b3-14 is 0 when you set the following.
  - A1-02 = 0, 2, 8
  - E9-01 = 0
  - b3-24 = 2 [Current Detection 2]
- Refer to *Parameters that Change from the Default Settings with A1-02 [Control Method Selection]* on page 125 for information on the initial value of b3-14 that applies when you set the following.
  - A1-02 = 1, 4, 8 [CL-V/f, AOLV, EZOLV]
  - E9-01 = 1, 2 [Permanent Magnet (PM), Synchronous Reluctance (SynRM)]
- When you change A1-02, b3-24, and E9-01, set b3-14 as well.

**0 : No**

The drive uses the frequency reference to detect the direction of motor rotation.

**1 : Yes**

The drive detects the direction of motor rotation during Speed Search.

### ■ b3-17: Speed Est Retry Current Level

| No. (Hex.)                | Name                          | Description   | Default (Range)    |
|---------------------------|-------------------------------|---|--------------------|
| b3-17<br>(01F0)<br>Expert | Speed Est Retry Current Level | <b>V/f</b> <b>CL-V/f</b> <b>OLV</b> <b>CLV</b> <b>AOLV</b> <b>OLV/PM</b> <b>AOLV/PM</b> <b>CLV/PM</b> <b>EZOLV</b><br>Sets the current level for the search retry function in Speed Estimation Speed Search as a percentage where drive rated current is a setting value of 100%. | 150%<br>(0 - 200%) |

When a large quantity of current flows during Speed Estimation Speed Search, the drive temporarily stops operation to prevent overvoltage and overcurrent. When the current is at the level set in b3-17, the drive tries speed search again.

### ■ b3-18: Speed Est Retry Detection Time

| No. (Hex.)                | Name                           | Description  | Default (Range)           |
|---------------------------|--------------------------------|--|---------------------------|
| b3-18<br>(01F1)<br>Expert | Speed Est Retry Detection Time | <b>V/f</b> <b>CL-V/f</b> <b>OLV</b> <b>CLV</b> <b>AOLV</b> <b>OLV/PM</b> <b>AOLV/PM</b> <b>CLV/PM</b> <b>EZOLV</b><br>Sets the length of time that the drive will wait to retry Speed Estimation Speed Search when too much current flow stopped the Speed Search. | 0.10 s<br>(0.00 - 1.00 s) |

When the current is more than the level set in *b3-17 [Speed Est Retry Current Level]* during the time set in *b3-18*, the drive tries speed search again.

### ■ b3-19: Speed Search Restart Attempts

| No. (Hex.)      | Name                          | Description   | Default (Range)           |
|-----------------|-------------------------------|---|---------------------------|
| b3-19<br>(01F2) | Speed Search Restart Attempts | <b>V/f</b> <b>CL-V/f</b> <b>OLV</b> <b>CLV</b> <b>AOLV</b> <b>OLV/PM</b> <b>AOLV/PM</b> <b>CLV/PM</b> <b>EZOLV</b><br>Sets the number of times to restart Speed Search if Speed Search does not complete. | 3 times<br>(0 - 10 times) |

If the drive does the number of Speed Search restarts set in this parameter, it will trigger an *SEr [Speed Search Retries Exceeded]* error.

### ■ b3-24: Speed Search Method Selection

| No. (Hex.)      | Name                          | Description  | Default (Range) |
|-----------------|-------------------------------|--|-----------------|
| b3-24<br>(01C0) | Speed Search Method Selection | <b>V/f</b> <b>CL-V/f</b> <b>OLV</b> <b>CLV</b> <b>AOLV</b> <b>OLV/PM</b> <b>AOLV/PM</b> <b>CLV/PM</b> <b>EZOLV</b><br>Sets the Speed Search method when starting the motor or when restoring power after a momentary power loss. | 2<br>(1, 2)     |

#### Note:

- If *A1-02 = 8 [Control Method Selection = EZOLV]*, the default settings differ depending on the setting of *E9-01 [Motor Type Selection]* and the drive model
  - *E9-01 = 0 [Induction (IM)]*
    - 2004 to 2313, 4002 to 4302: 1
    - 2360, 2415, 4371 to 4720: 2
  - *E9-01 = 1, 2 [Permanent Magnet (PM), Synchronous Reluctance (SynRM)]*: 1
- If *A1-02 = 8* and *E9-01 = 1, 2*, set *b3-24 = 1*. The drive will detect *oPE08 [Parameter Selection Error]* if *b3-24 = 2*.

Set *b3-01 = 1 [Speed Search at Start Selection = Enabled]* to do Speed Search at start. Set *L2-01 = 1 [Power Loss Ride Through Select = Enabled for L2-02 Time]* to do Speed Search after you restore power after a momentary power loss.

#### 1 : Speed Estimation

The drive uses the residual voltage from a short baseblock time to estimate the motor speed.

If there is not sufficient residual voltage, then the drive will inject DC current into the motor to estimate the motor speed.

#### 2 : Current Detection 2

The drive will inject DC current into the motor to estimate motor speed.

### ■ b3-25: Speed Search Wait Time

| No. (Hex.)                | Name                   | Description   | Default (Range)         |
|---------------------------|------------------------|---|-------------------------|
| b3-25<br>(01C8)<br>Expert | Speed Search Wait Time | <b>V/f</b> <b>CL-V/f</b> <b>OLV</b> <b>CLV</b> <b>AOLV</b> <b>OLV/PM</b> <b>AOLV/PM</b> <b>CLV/PM</b> <b>EZOLV</b><br>Sets the length of time the drive will wait to start the Speed Search Retry function. | 0.5 s<br>(0.0 - 30.0 s) |

If the drive detects these faults during speed search, increase the setting value:

- *oC [Overcurrent]*
- *ov [Overvoltage]*
- *SEr [Speed Search Retries Exceeded]*

## 2.3 b: Application

### ■ b3-26: Direction Determination Level

| No. (Hex.)                | Name                          | Description   | Default (Range)       |
|---------------------------|-------------------------------|---|-----------------------|
| b3-26<br>(01C7)<br>Expert | Direction Determination Level | <div style="display: flex; gap: 5px;"> <span>V/f</span> <span>CL-V/f</span> <span>OLV</span> <span>CLV</span> <span>AOLV</span> <span>OLV/PM</span> <span>AOLV/PM</span> <span>CLV/PM</span> <span>EZOLV</span> </div> <p>Sets the level to find the motor rotation direction. Increase the value if the drive cannot find the direction.</p> | 1000<br>(40 to 60000) |

### ■ b3-27: Speed Search RUN/BB Priority

| No. (Hex.)                | Name                         | Description  | Default (Range) |
|---------------------------|------------------------------|--|-----------------|
| b3-27<br>(01C9)<br>Expert | Speed Search RUN/BB Priority | <div style="display: flex; gap: 5px;"> <span>V/f</span> <span>CL-V/f</span> <span>OLV</span> <span>CLV</span> <span>AOLV</span> <span>OLV/PM</span> <span>AOLV/PM</span> <span>CLV/PM</span> <span>EZOLV</span> </div> <p>Sets the conditions necessary to start Speed Search.</p> | 0<br>(0, 1)     |

Executes *Speed Search from Fmax or Fref* [ $H1-xx = 61/62$ ] for initial speed searches or from the MFDI terminal.

**0 : SS Only if RUN Applied Before BB**

**1 : SS Regardless of RUN/BB Sequence**

### ■ b3-29: Speed Search Back-EMF Threshold

| No. (Hex.)                | Name                            | Description   | Default (Range)  |
|---------------------------|---------------------------------|---|------------------|
| b3-29<br>(077C)<br>Expert | Speed Search Back-EMF Threshold | <div style="display: flex; gap: 5px;"> <span>V/f</span> <span>CL-V/f</span> <span>OLV</span> <span>CLV</span> <span>AOLV</span> <span>OLV/PM</span> <span>AOLV/PM</span> <span>CLV/PM</span> <span>EZOLV</span> </div> <p>Sets the induced voltage for motors that use Speed Search. The drive will start Speed Search when the motor induced voltage level is the same as the setting value. Usually it is not necessary to change this setting.</p> | 10%<br>(0 - 10%) |

To make adjustments, gradually decrease the setting value. If you decrease the setting value too much, speed search will not operate correctly.

### ■ b3-31: Spd Search Current Reference Lvl

| No. (Hex.)                | Name                             | Description   | Default (Range)       |
|---------------------------|----------------------------------|---|-----------------------|
| b3-31<br>(0BC0)<br>Expert | Spd Search Current Reference Lvl | <div style="display: flex; gap: 5px;"> <span>V/f</span> <span>CL-V/f</span> <span>OLV</span> <span>CLV</span> <span>AOLV</span> <span>OLV/PM</span> <span>AOLV/PM</span> <span>CLV/PM</span> <span>EZOLV</span> </div> <p>Sets the current level that decreases the output current during Current Detection Speed Search.</p> | 1.50<br>(1.50 - 3.50) |

Set this parameter as a ratio of  $E2-03$  [Motor No-Load Current]. The setting is a ratio with respect to 30% of the motor rated current if  $E2-03 \leq E2-01$  [Motor Rated Current] x 0.3.

**Note:**

The setting is a ratio with respect to  $E9-06$  [Motor Rated Current] x 0.5 if  $A1-02 = 8$  [Control Method Selection = EZOLV].

### ■ b3-32: Spd Search Current Complete Lvl

| No. (Hex.)                | Name                            | Description   | Default (Range)       |
|---------------------------|---------------------------------|---|-----------------------|
| b3-32<br>(0BC1)<br>Expert | Spd Search Current Complete Lvl | <div style="display: flex; gap: 5px;"> <span>V/f</span> <span>CL-V/f</span> <span>OLV</span> <span>CLV</span> <span>AOLV</span> <span>OLV/PM</span> <span>AOLV/PM</span> <span>CLV/PM</span> <span>EZOLV</span> </div> <p>Sets the current level that completes Speed Search.</p> | 1.20<br>(0.00 - 1.49) |

The Current Detection Speed Search gradually decreases the output frequency to search for the motor speed when the output current is equal to or less than Speed Search Current Complete Level.

Set this parameter as a ratio of  $E2-03$  [Motor No-Load Current]. The setting is a ratio with respect to 30% of the motor rated current if  $E2-03 \leq E2-01$  [Motor Rated Current] x 0.3.

**Note:**

The setting is a ratio with respect to  $E9-06$  [Motor Rated Current] x 0.5 if  $A1-02 = 8$  [Control Method Selection = EZOLV].



### ■ b3-33: Speed Search during Uv Selection

| No. (Hex.)                | Name                             | Description  | Default (Range) |
|---------------------------|----------------------------------|--|-----------------|
| b3-33<br>(0B3F)<br>Expert | Speed Search during Uv Selection | <div style="display: flex; gap: 5px;"> <span>V/f</span> <span>CL-V/f</span> <span>OLV</span> <span>CLV</span> <span>AOLV</span> <span>OLV/PM</span> <span>AOLV/PM</span> <span>CLV/PM</span> <span>EZOLV</span> </div> <p>Sets the function that starts Speed Search at start-up if the drive detects a <i>Uv [Undervoltage]</i> when it receives a Run command.</p> | 1<br>(0, 1)     |

Set these three parameters as shown to enable *b3-33*:

- *L2-01 = 1, 2 [Power Loss Ride Through Select = Enabled for L2-02 Time, Enabled while CPU Power Active]*
- *b3-01 = 1 [Speed Search at Start Selection = Enabled]*
- *b1-03 = 1 [Stopping Method Selection = Coast to Stop]*

**0 : Disabled**

**1 : Enabled**

### ■ b3-35: Low Back EMF Detection Level

| No. (Hex.)                | Name                         | Description  | Default (Range)  |
|---------------------------|------------------------------|--|------------------|
| b3-35<br>(0BC3)<br>Expert | Low Back EMF Detection Level | <div style="display: flex; gap: 5px;"> <span>V/f</span> <span>CL-V/f</span> <span>OLV</span> <span>CLV</span> <span>AOLV</span> <span>OLV/PM</span> <span>AOLV/PM</span> <span>CLV/PM</span> <span>EZOLV</span> </div> <p>Sets the Low Back EMF Detection Level. Usually it is not necessary to change this setting.</p> | 10%<br>(5 - 50%) |

### ■ b3-36: High Back EMF Detection Level

| No. (Hex.)                | Name                          | Description  | Default (Range)          |
|---------------------------|-------------------------------|--|--------------------------|
| b3-36<br>(0BC4)<br>Expert | High Back EMF Detection Level | <div style="display: flex; gap: 5px;"> <span>V/f</span> <span>CL-V/f</span> <span>OLV</span> <span>CLV</span> <span>AOLV</span> <span>OLV/PM</span> <span>AOLV/PM</span> <span>CLV/PM</span> <span>EZOLV</span> </div> <p>Sets the voltage level for Speed Search restart. Usually it is not necessary to change this setting.</p> | 0.970<br>(0.500 - 1.000) |

The drives wait for Speed Search to prevent failure when the induced voltage for the motor during coasting to a stop is larger than the voltage the drive can output. The drive will not restart the motor (Speed Search) if induced voltage  $\geq$  supply voltage  $\times$  *b3-36* after a Run command is entered. The drive will restart the motor when the condition of induced voltage  $<$  supply voltage  $\times$  *b3-36* is met. For example, if the setting value is 0.83 and the voltage does not decrease to the induced voltage at approximately 183 V when the power supply voltage is 220 V, the drive will not do restart.

### ■ b3-54: Search Time

| No. (Hex.)      | Name        | Description   | Default (Range)          |
|-----------------|-------------|---|--------------------------|
| b3-54<br>(3123) | Search Time | <div style="display: flex; gap: 5px;"> <span>V/f</span> <span>CL-V/f</span> <span>OLV</span> <span>CLV</span> <span>AOLV</span> <span>OLV/PM</span> <span>AOLV/PM</span> <span>CLV/PM</span> <span>EZOLV</span> </div> <p>Sets the length of time that the drive will run Speed Search.</p> | 400 ms<br>(10 - 2000 ms) |

If you set this parameter too low, Speed Search will not operate correctly.

If the drive detects *oC [Overcurrent]* immediately after Speed Search Starts:

- Increase the value of *L2-03 [Minimum Baseblock Time]* and decrease the motor speed you use to start Speed Search.
- Increases the setting value of *b3-08 [Speed Estimation ACR P Gain]*.
- Increase the value of *b3-54*.

If the drive detects *oC* or *ov [DC Bus Overvoltage]* during Speed Search, increase the value of *b3-08*.

## 2.3 b: Application

### ■ b3-55: Current Increment Time

| No. (Hex.)                | Name                   | Description   | Default (Range)         |
|---------------------------|------------------------|---|-------------------------|
| b3-55<br>(3124)<br>Expert | Current Increment Time | V/f CL-V/f OLV CLV AOLV OLV/PM AOLV/PM CLV/PM EZOLV<br>Sets the length of time that the drive will increase the current from zero current to the setting value of b3-06 [Speed Estimation Current Level]. | 10 ms<br>(10 - 2000 ms) |

Gradually increase the setting value when a large quantity of current flows after speed search starts. If you set this value too high, speed search will not operate correctly.

### ■ b3-56: InverseRotationSearch WaitTime

| No. (Hex.)      | Name                           | Description  | Default (Range)                      |
|-----------------|--------------------------------|--|--------------------------------------|
| b3-56<br>(3126) | InverseRotationSearch WaitTime | V/f CL-V/f OLV CLV AOLV OLV/PM AOLV/PM CLV/PM EZOLV<br>Sets the wait time until inverse rotation search starts after the completion of forward search if inverse rotation search is performed during Current Detection Speed Search. | Determined by o2-04<br>(0.1 - 5.0 s) |

### ■ b3-61: Initial Pole Detection Gain

| No. (Hex.)                | Name                                     | Description   | Default (Range)        |
|---------------------------|--|---|------------------------|
| b3-61<br>(1B96)<br>Expert | Response Gain for Initial Pole Detection | V/f CL-V/f OLV CLV AOLV OLV/PM AOLV/PM CLV/PM EZOLV<br>Adjusts the Initial Pole Detection response gain when A1-02 = 6 [Control Method Selection = AOLV/PM]. Set b3-61 > 0.0 for an ordinary IPM motor. | 5.0<br>(-20.0 - +20.0) |

Use this when n8-35 = 1 [Initial Pole Detection Method = High Frequency Injection]. Adjusts the response gain for Initial Pole Detection. Specify a positive value for an ordinary motor. The drive sets this value automatically when High Frequency Injection Tuning completes correctly.

## ◆ b4: Timer Function

The drive uses timers to delay activating and deactivating MFDO terminals.

Timers prevent sensors and switches from making chattering noise.

There are two types of timers:

- Timers that set a delay for timer inputs and timer outputs.  
These timers delay activating and deactivating of the MFDIs and MFDOs.  
To enable this function, set H1-xx = 18 [MFDI Function Select = Timer Function], and set H2-01 to H2-03 = 12 [MFDO Function Select = Timer Output].
- Timers that set a delay to activate and deactivate MFDO terminals.  
These timers delay activating and deactivating MFDO terminals.  
To enable this function, set delay times in parameters b4-03 to b4-08.

### ■ Timer Function Operation

- Timers that set a delay for timer inputs and timer outputs  
Triggers timer output if the timer input is active for longer than the time set in b4-01 [Timer Function ON-Delay Time]. Triggers timer output late for the time set in b4-02 [Timer Function OFF-Delay Time]. Figure 2.32 shows an example of how the timer function works.

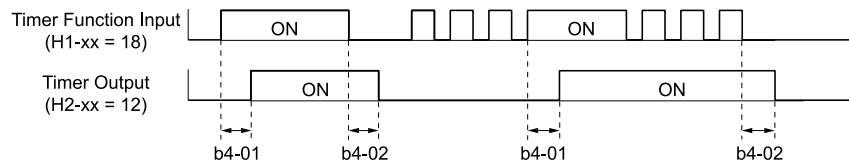


Figure 2.32 Example of Timer Function Operation

- Setting on/off-delay time for MFDO  
Figure 2.33 uses H2-01 terminals to show an example of how the timer function works. Use b4-03 [Terminal M1-M2 ON-Delay Time] and b4-04 [Terminal M1-M2 OFF-Delay Time] to set this function.

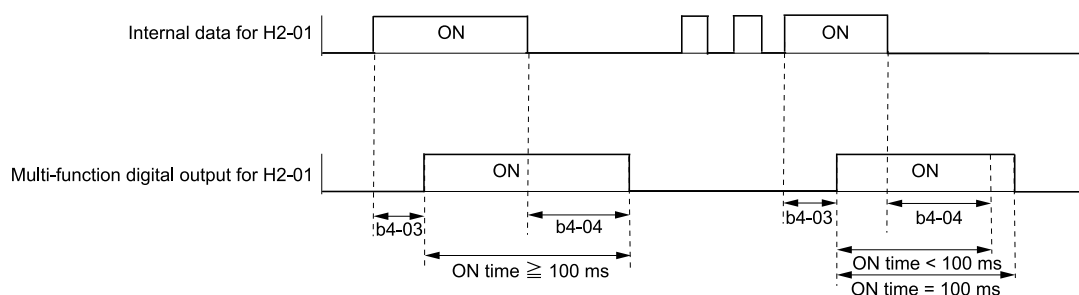


Figure 2.33 Example of How the Timer Function Works with H2-01 Terminals

**Note:**

When the terminal is triggered, it continues for a minimum of 100 ms. The on/off-delay time of MFDO terminal does not have an effect.

■ **b4-01: Timer Function ON-Delay Time**

| No. (Hex.)   | Name                         | Description   | Default (Range)           |
|--------------|------------------------------|---|---------------------------|
| b4-01 (01A3) | Timer Function ON-Delay Time | <b>V/f</b> <b>CL-V/f</b> <b>OLV</b> <b>CLV</b> <b>AOLV</b> <b>OLV/PM</b> <b>AOLV/PM</b> <b>CLV/PM</b> <b>EZOLV</b><br>Sets the ON-delay time for the timer input. | 0.0 s<br>(0.0 - 3000.0 s) |

■ **b4-02: Timer Function OFF-Delay Time**

| No. (Hex.)   | Name                          | Description  | Default (Range)           |
|--------------|-------------------------------|--|---------------------------|
| b4-02 (01A4) | Timer Function OFF-Delay Time | <b>V/f</b> <b>CL-V/f</b> <b>OLV</b> <b>CLV</b> <b>AOLV</b> <b>OLV/PM</b> <b>AOLV/PM</b> <b>CLV/PM</b> <b>EZOLV</b><br>Sets the OFF-delay time for the timer input. | 0.0 s<br>(0.0 - 3000.0 s) |

■ **b4-03: Terminal M1-M2 ON-Delay Time**

| No. (Hex.)             | Name                | Description   | Default (Range)        |
|------------------------|---------------------|---|------------------------|
| b4-03 (0B30)<br>Expert | H2-01 ON Delay Time | <b>V/f</b> <b>CL-V/f</b> <b>OLV</b> <b>CLV</b> <b>AOLV</b> <b>OLV/PM</b> <b>AOLV/PM</b> <b>CLV/PM</b> <b>EZOLV</b><br>Sets the delay time until the contact is turned ON after the function set with <i>H2-01</i> turns ON. | 0 ms<br>(0 - 65000 ms) |

■ **b4-04: Terminal M1-M2 OFF-Delay Time**

| No. (Hex.)             | Name                          | Description   | Default (Range)        |
|------------------------|-------------------------------|---|------------------------|
| b4-04 (0B31)<br>Expert | Terminal H2-01 OFF-Delay Time | <b>V/f</b> <b>CL-V/f</b> <b>OLV</b> <b>CLV</b> <b>AOLV</b> <b>OLV/PM</b> <b>AOLV/PM</b> <b>CLV/PM</b> <b>EZOLV</b><br>Sets the delay time to deactivate the contact after the function set in <i>H2-01</i> deactivates. | 0 ms<br>(0 - 65000 ms) |

■ **b4-05: Terminal M3-M4 ON-Delay Time**

| No. (Hex.)             | Name                         | Description   | Default (Range)        |
|------------------------|------------------------------|---|------------------------|
| b4-05 (0B32)<br>Expert | Terminal H2-02 ON-Delay Time | <b>V/f</b> <b>CL-V/f</b> <b>OLV</b> <b>CLV</b> <b>AOLV</b> <b>OLV/PM</b> <b>AOLV/PM</b> <b>CLV/PM</b> <b>EZOLV</b><br>Sets the delay time to activate the contact after the function set in <i>H2-02</i> activates. | 0 ms<br>(0 - 65000 ms) |

■ **b4-06: Terminal M3-M4 OFF-Delay Time**

| No. (Hex.)             | Name                          | Description   | Default (Range)        |
|------------------------|-------------------------------|---|------------------------|
| b4-06 (0B33)<br>Expert | Terminal H2-02 OFF-Delay Time | <b>V/f</b> <b>CL-V/f</b> <b>OLV</b> <b>CLV</b> <b>AOLV</b> <b>OLV/PM</b> <b>AOLV/PM</b> <b>CLV/PM</b> <b>EZOLV</b><br>Sets the delay time to deactivate the contact after the function set in <i>H2-02</i> deactivates. | 0 ms<br>(0 - 65000 ms) |

## 2.3 b: Application

### ■ b4-07: Terminal M5-M6 ON-Delay Time

| No. (Hex.)                | Name                         | Description   | Default (Range)        |
|---------------------------|------------------------------|---|------------------------|
| b4-07<br>(0B34)<br>Expert | Terminal M5-M6 ON-Delay Time | <b>V/f</b> <b>CL-V/f</b> <b>OLV</b> <b>CLV</b> <b>AOLV</b> <b>OLV/PM</b> <b>AOLV/PM</b> <b>CLV/PM</b> <b>EZOLV</b><br>Sets the delay time to activate the contact after the function set in <i>H2-03</i> activates. | 0 ms<br>(0 - 65000 ms) |

### ■ b4-08: Terminal M5-M6 OFF-Delay Time

| No. (Hex.)                | Name                          | Description   | Default (Range)        |
|---------------------------|-------------------------------|---|------------------------|
| b4-08<br>(0B35)<br>Expert | Terminal M5-M6 OFF-Delay Time | <b>V/f</b> <b>CL-V/f</b> <b>OLV</b> <b>CLV</b> <b>AOLV</b> <b>OLV/PM</b> <b>AOLV/PM</b> <b>CLV/PM</b> <b>EZOLV</b><br>Sets the delay time to deactivate the contact after the function set in <i>H2-03</i> deactivates. | 0 ms<br>(0 - 65000 ms) |

### ◆ b5: PID control

The drive has a PID control function. You can control drive output to adjust the proportional gain, integral time, and derivative time that has an effect on the bias between the target value and the feedback value to match the target value to the detected value. Use this function to adjust the drive output to accurately match the flow, pressure, and temperature in the application match the target value.

Use a combination of these controls to increase the performance:

- P control  
P control has a proportional effect on the deviation. It outputs the product (the controlled output) proportional to the deviation. You cannot use only the offset from P control to get to zero deviation.
- I control  
I control is the integral of the deviation. It uses an integral value of the deviation to output the product (the controlled output). I control helps align the feedback value and the target value. An offset occurs if you use the proportional effect (P Control) only. If you use the proportional effect in conjunction with the integral operation, the offset vanishes over time.
- D control  
D control is the derivative of the deviation. It has an effect on drive output when there are sudden, large changes in the deviation or feedback value. It quickly returns drive output to the value before the sudden change. It multiplies a time constant by a derivative value of the deviation (slope of the deviation), and adds that result to PID input to calculate the deviation of the signal, then it corrects the deviation.

**Note:**

D control has causes less stable operation because the noise changes the deviation signal. Use D control only when necessary.

### ■ PID Control Operation

Figure 2.34 shows PID control operation. The modified output (output frequency) changes when the drive uses PID control to keep the deviation (the difference between the target value and the feedback value) constant.

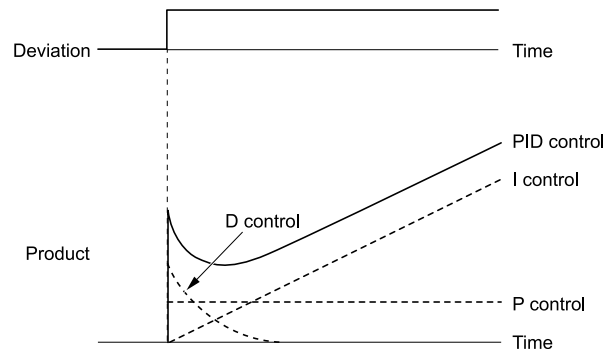


Figure 2.34 PID Control Operation

## ■ PID Control Applications

Table 2.24 shows applications for PID control.

**Table 2.24 PID Control Applications**

| Application         | Control content   | Sensors Used              |
|---------------------|---|---------------------------|
| Speed Control       | <ul style="list-style-type: none"> <li>The drive uses a feedback signal for the machine speed, and adjusts that speed to align with the target value.</li> <li>The drive uses speed data from other machinery as the target value to do synchronous control. The drive then adds that target value to the feedback from the machine it is operating to align its speed with the other machinery.</li> </ul> | Tacho generator           |
| Pressure control    | The drive uses feedback from the actual pressure to hold constant pressure.   | Pressure sensor           |
| Flow control        | The drive uses feedback from the actual flow to hold constant flow.   | Flow rate sensor          |
| Temperature control | The drive uses feedback from the actual temperature to control a fan and hold constant temperature.   | Thermocoupler, thermistor |

## ■ Input Methods for the PID Setpoint

Use *b5-01 [PID Function Setting]* to select how the PID setpoint is input to the drive.

When *b5-01 = 1 or 2 [PID Mode Setting = Standard or Standard (D on feedback)]*, the frequency reference set in *b1-01 [Frequency Reference Selection 1]* or *b1-15 [Frequency Reference Selection 2]* will be the PID setpoint, or the one of the values shown in Table 2.25 will be the PID setpoint.

When *b5-01 = 3 or 4 [PID Mode Setting = Fref + PID Trim or Fref + PID Trim (D on feedback)]*, one of the inputs in Table 2.25 will be the PID setpoint.

**Table 2.25 Input Methods for the PID Setpoint**

| Input Methods for the PID Setpoint      | Setting Value   |
|---|---|
| Multi-function analog input terminal A1 | Set <i>H3-02 = C [Terminal A1 Function Selection = PID Setpoint]</i> .  |
| Multi-function analog input terminal A2 | Set <i>H3-10 [Terminal A2 Function Selection] = C</i> .   |
| Multi-function analog input terminal A3 | Set <i>H3-06 [Terminal A3 Function Selection] = C</i> .   |
| MEMOBUS/Modbus register 0006H           | Sets MEMOBUS/Modbus register 000FH (Control Selection Setting) bit 1 to 1 (PID setpoint input). Enters the PID setpoint to MEMOBUS/Modbus register 0006H (PID Target, 0.01% units, signed). |
| Pulse train input terminal RP           | Set <i>H6-01 = 2 [Terminal RP Pulse Train Function = PID Setpoint Value]</i> .  |
| <i>b5-19 [PID Setpoint Value]</i>       | Set <i>b5-18 = 1 [b5-19 PID Setpoint Selection = Enabled]</i> . Enters the PID setpoint to <i>b5-19</i> .   |

**Note:**

If you set two inputs for the PID setpoint, it will trigger operation error *oPE07 [Analog Input Selection Error]*.

## ■ Entering the PID Feedback Value

You can use two methods to input the PID feedback value to the drive. One method uses a single feedback signal for usual PID control. The other method uses two signals. The difference between those signals sets the deviation.

- **Use one feedback signal.**

Use Table 2.26 to select how the feedback signal is input to the drive for PID control.

**Table 2.26 PID Feedback Input Method**

| PID Feedback Input Method               | Setting Value                               |
|---|---|
| Multi-function analog input terminal A1 | Set <i>H3-02 = B [PID Feedback]</i> .       |
| Multi-function analog input terminal A2 | Set <i>H3-10 = B</i> .                      |
| Multi-function analog input terminal A3 | Set <i>H3-06 = B</i> .                      |
| Pulse train input terminal RP           | Set <i>H6-01 = 1 [PID feedback value]</i> . |

- **The drive uses two feedback signals, and the difference between those signals becomes the deviation.**

Use to select how the second feedback signal is input to the drive.

## 2.3 b: Application

Use Table 2.27 to select how the second feedback value is input to the drive. The drive calculates the deviation of the second feedback value. Set  $H3-02$ ,  $H3-06$ , or  $H3-10 = 16$  [Terminal A1/A3/A2 Function Selection = Differential PID Feedback] to enable the second feedback signal used to calculate the deviation.

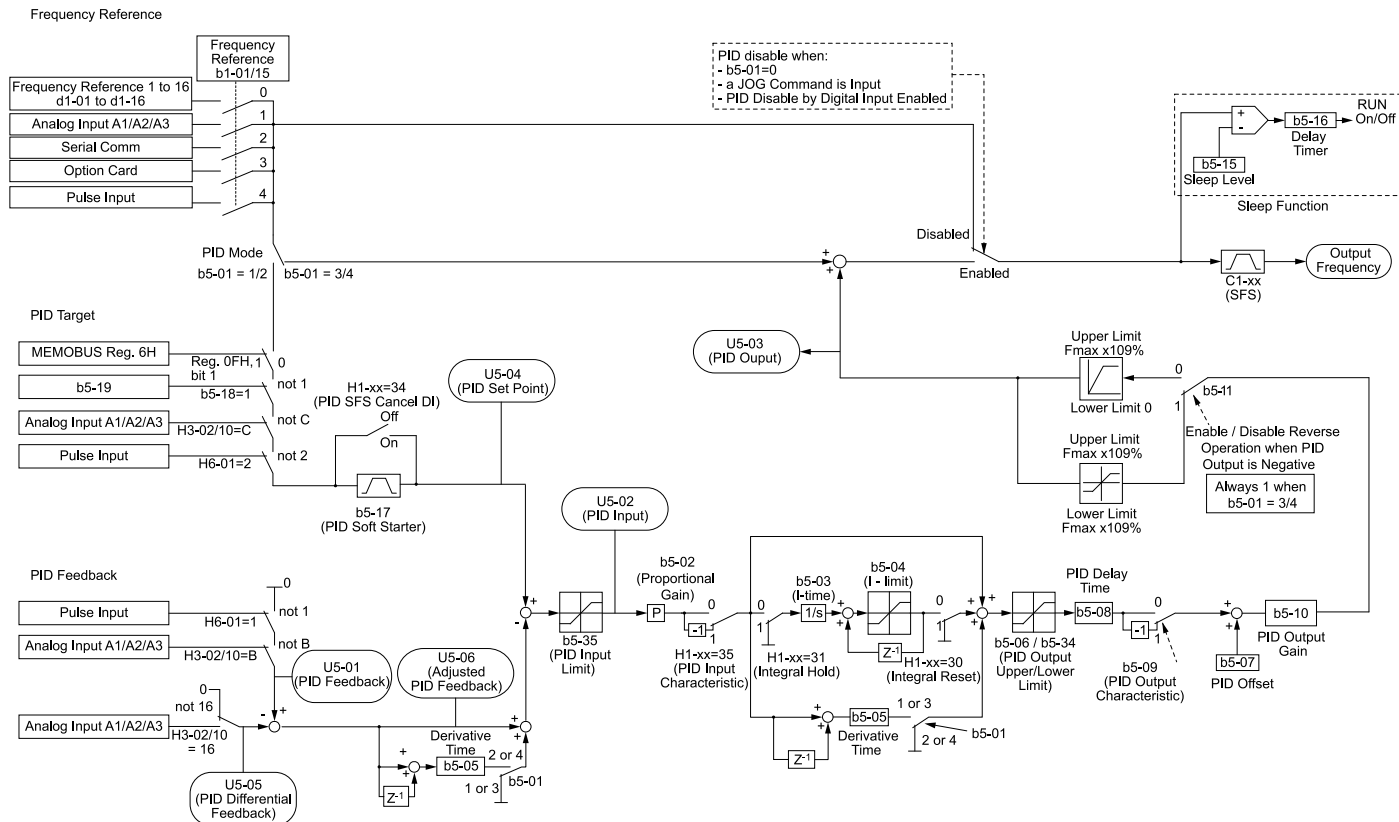
**Table 2.27 PID Differential Feedback Input Method**

| PID Differential Feedback Input Method  | Setting Value                                 |
|---|---|
| Multi-function analog input terminal A1 | Set $H3-02 = 16$ [Differential PID Feedback]. |
| Multi-function analog input terminal A2 | Set $H3-10 = 16$ .                            |
| Multi-function analog input terminal A3 | Set $H3-06 = 16$ .                            |

**Note:**

If you set more than one of  $H3-02$ ,  $H3-06$ , and  $H3-10$  to 16, it will trigger  $oPE07$  [Analog Input Selection Error].

## PID Control Block Diagram



**Figure 2.35 PID Block Diagram**

## PID Feedback Loss Detection

The PID feedback loss detection function detects broken sensors and defective wiring between the drive and sensors. Use the PID feedback loss detection function when you use PID control. If the feedback signal is too low, the motor can suddenly accelerate to the maximum output frequency. This function prevents such risks to the load.

The drive uses two methods to detect feedback loss:

- **PID Feedback Loss [FbL]**

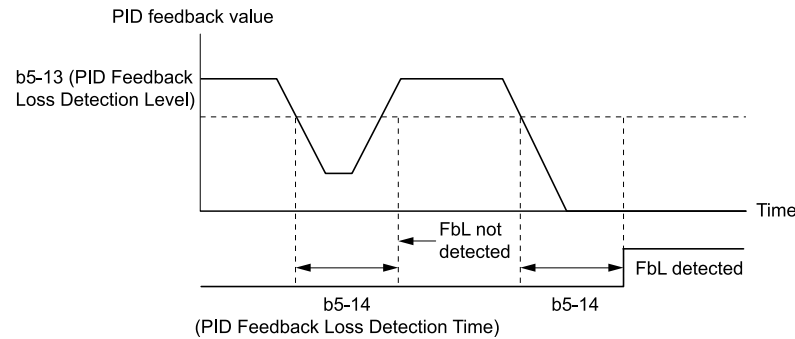
Set these parameters for the PID feedback loss detection function.

The drive detects feedback loss when the feedback value is less than the value in  $b5-13$  for longer than the time in  $b5-14$ .

- $b5-12$  [Feedback Loss Detection Select]
- $b5-13$  [PID Feedback Loss Detection Lvl]
- $b5-14$  [PID Feedback Loss Detection Time]

- *Excessive PID Feedback [FbH]*  
Set these parameters to set how the drive detects a feedback level that is too high.  
The drive detects too much PID feedback when the feedback value is more than the value in *b5-36* for longer than the time in *b5-37*.
  - *b5-12 [Feedback Loss Detection Select]*
  - *b5-36 [PID High Feedback Detection Lvl]*
  - *b5-37 [PID High Feedback Detection Time]*

Figure 2.36 shows the operation principle when the feedback value is too low, and the drive detects feedback loss. The operation is the same when the drive detects too much feedback.



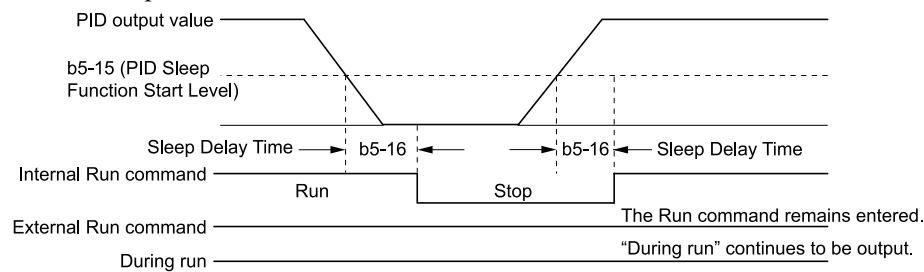
**Figure 2.36** Time Chart for PID Feedback Loss Detection Time

## ■ PID Sleep

PID sleep stops drive operation when the PID output or the frequency reference is less than *b5-15 [PID Sleep Function Start Level]*. This function shuts off drive output after the motor decelerates to the set frequency.

The drive will automatically restart the motor when the PID output or the frequency reference is more than the *b5-15* value for the time set in *b5-16 [PID Sleep Delay Time]*.

Figure 2.37 shows the PID Sleep function.



**Figure 2.37** PID Sleep Time Chart

### Note:

- The PID Sleep function is enabled when PID control is disabled.
- When the PID Sleep function is triggered, the drive will stop the motor as specified by *b1-03 [Stopping Method Selection]*.

## ■ Fine-Tuning PID

Fine-tune the following parameter settings to have PID control eliminate problems with overshoot and oscillation.

- *b5-02 [Proportional Gain (P)]*
- *b5-03 [Integral Time (I)]*
- *b5-05 [Derivative Time (D)]*
- *b5-08 [PID Primary Delay Time Constant]*

## 2.3 b: Application

| Purpose                           | Procedure  | Results  |
|-----------------------------------|--|--|
| Prevent overshoot.                | <ul style="list-style-type: none"> <li>Set <i>b5-05</i> [Derivative Time (D)] to a smaller value.</li> <li>Set <i>b5-03</i> [Integral Time (I)] to a larger value.</li> </ul>  | <p>Response</p> <p>Before adjustment</p> <p>After adjustment</p> <p>Time</p> |
| Quickly stabilize control.        | <ul style="list-style-type: none"> <li>Set <i>b5-05</i> [Derivative Time (D)] to a larger value.</li> <li>Set <i>b5-03</i> [Integral Time (I)] to a smaller value.</li> </ul>  | <p>Response</p> <p>After adjustment</p> <p>Before adjustment</p> <p>Time</p> |
| Prevent long-cycle oscillations.  | Set <i>b5-03</i> [Integral Time (I)] to a larger value.  | <p>Response</p> <p>Before adjustment</p> <p>After adjustment</p> <p>Time</p> |
| Prevent short-cycle oscillations. | <ul style="list-style-type: none"> <li>Set <i>b5-05</i> [Derivative Time (D)] to a smaller value.</li> <li>If you set <i>b5-05</i> = 0.00 [Derivative Time (D) = disabling D control] and it does not stop oscillation, then set <i>b5-02</i> [Proportional Gain (P)] to a smaller value or set <i>b5-08</i> [PID Primary Delay Time Constant] to a larger value.</li> </ul> | <p>Response</p> <p>Before adjustment</p> <p>After adjustment</p> <p>Time</p> |

### ■ EZ Sleep/Wake-up Functionality

Set *b5-89* = 1 [Sleep Method Selection = EZ Sleep/Wake-up] to enable the EZ Sleep/Wake-up function.

**Note:**

- When *b5-89* = 0 [Sleep Mode Selection = Standard], the EZ Sleep function and related parameters are disabled. Parameter *b5-91* [EZ Minimum Speed] is not included in this rule.
- Set *b5-89* = 1 to disable *b5-15* [PID Sleep Function Start Level].



| Configuration Parameter                             | Description  |
|---|--|
| <i>b5-90 [EZ Sleep Unit]</i>                        | Sets the unit of measure for <i>b5-92 [EZ Sleep Level]</i> . When <i>b5-90 = 0 [0.1Hz units]</i> , the setting range of <i>b5-91 [EZ Minimum Speed]</i> is 0.0 to 590.0 Hz. When <i>b5-90 = 1 [rev/min]</i> , the setting range is 0 to 35400 min <sup>-1</sup> (r/min).<br><b>Note:</b><br>When you change <i>b5-90</i> , the value of <i>b5-92</i> is not automatically updated. |
| <i>b5-91 [EZ Minimum Speed]</i>                     | This parameter sets the lower limit for PID output. The drive uses the largest value of <i>b5-91</i> , <i>b5-34 [PID Output Lower Limit]</i> , and <i>d2-02 [Frequency Reference Lower Limit]</i> to internally set the lower limit of PID output. The <i>b5-89</i> setting does not have an effect.   |
| <i>b5-92 [EZ Sleep Level]</i>                       | When the output frequency or motor speed is less than the value of <i>b5-92</i> for longer than the value of <i>b5-93 [EZ Sleep Time]</i> , the drive does to sleep.   |
| <i>b5-95 = 0 [EZ Wake-up Mode = Absolute]</i>       | When the PID feedback is less than the value of <i>b5-94 [EZ Wake-up Level]</i> for longer than the time set in <i>b5-96 [EZ Sleep Wake-up Time]</i> , the drive restarts operation from sleep.  |
| <i>b5-95 = 1 [EZ Wake-up Mode = Setpoint Delta]</i> | When the PID feedback is less than the value set as the PID setpoint value minus <i>b5-94</i> for the time set in <i>b5-96</i> , the drive restarts operation from sleep.  |

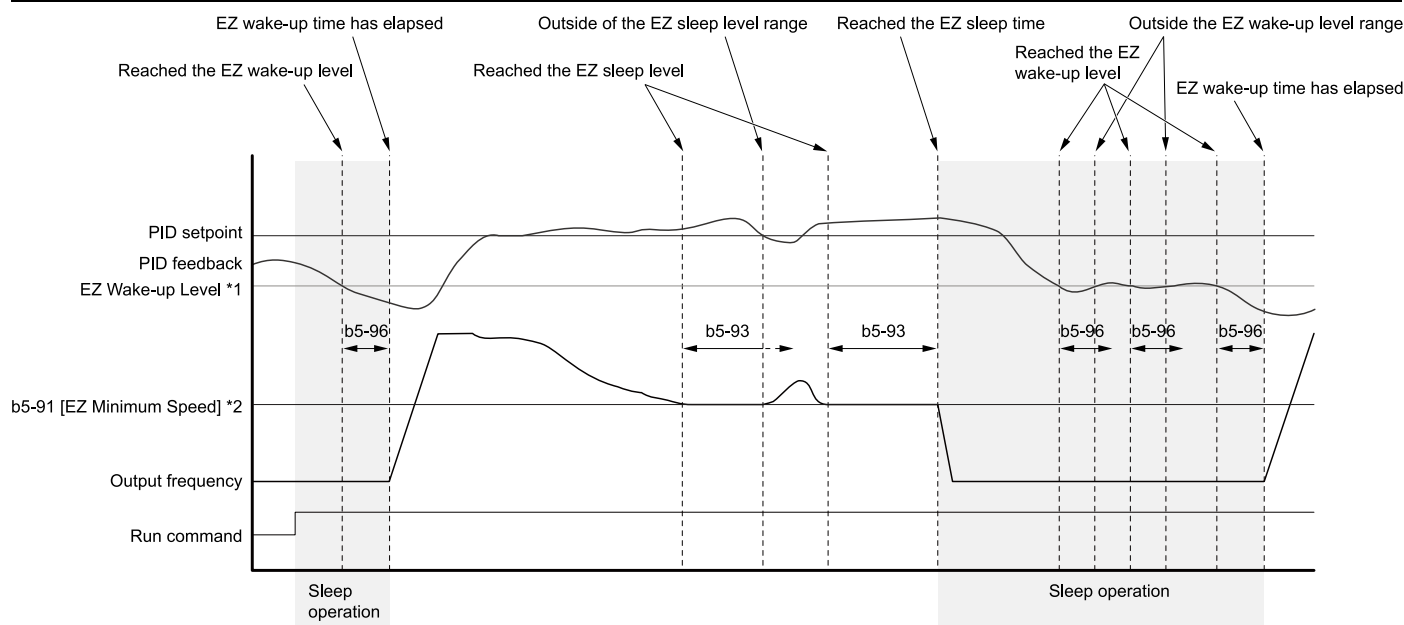


Figure 2.38 EZ Sleep/Wake-up Operation: PID Output is Normal and  $b5-92 = 0.0$  Hz

\*1 The values of *b5-94* and *b5-95* set operation.

\*2 In the example, *b5-92* is at the default setting of 0.0 Hz. *b5-91* is the EZ sleep level.

### ■ b5-01: PID Mode Setting

| No. (Hex.)   | Name             | Description  | Default (Range) |
|--------------|------------------|--|-----------------|
| b5-01 (01A5) | PID Mode Setting | <input checked="" type="checkbox"/> V/f <input type="checkbox"/> CL-V/f <input type="checkbox"/> OLV <input type="checkbox"/> CLV <input type="checkbox"/> AOLV <input type="checkbox"/> OLV/PM <input type="checkbox"/> AOLV/PM <input type="checkbox"/> CLV/PM <input type="checkbox"/> EZOLV<br>Sets the type of PID control. | 0 (0 - 8)       |

#### 0 : Disabled

#### 1 : Standard

The drive does D control on the difference between the feedback value and the PID setpoint output through *U5-02 [PID Input]*.

#### 2 : Standard (D on feedback)

The drive does D control on the feedback output through *U5-06 [PID Fdbk-Diff PID Fdbk]*.

#### 3 : Fref + PID Trim

The drive adds the frequency reference to the PID output. The drive performs D control on the difference between the feedback value and the PID setpoint output via *U5-02 [PID Input]*.

#### 4 : Fref + PID Trim (D on feedback)

## 2.3 b: Application

The drive adds the frequency reference to the PID output. The drive performs D control on the feedback output via *U5-06 [PID Fdbk-Diff PID Fdbk]*.

**5 : Same as 7series & prior, b5-01=1**

**6 : Same as 7series & prior, b5-01=2**

**7 : Same as 7series & prior, b5-01=3**

**8 : Same as 7series & prior, b5-01=4**

**Note:**

Use settings 5 to 8 when the drive is a replacement for a previous generation drive.

### ■ b5-02: Proportional Gain (P)

| No. (Hex.)             | Name                  | Description  | Default (Range)        |
|------------------------|-----------------------|--|------------------------|
| b5-02<br>(01A6)<br>RUN | Proportional Gain (P) | <b>V/f</b> <b>CL-V/f</b> <b>OLV</b> <b>CLV</b> <b>AOLV</b> <b>OLV/PM</b> <b>AOLV/PM</b> <b>CLV/PM</b> <b>EZOLV</b><br>Sets the proportional gain (P) that is applied to PID input. | 1.00<br>(0.00 - 25.00) |

Larger values decrease errors, but can cause oscillations. Smaller values let too much offset between the setpoint and feedback.

Set *b5-02 = 0.00* to disable P control.

### ■ b5-03: Integral Time (I)

| No. (Hex.)             | Name              | Description  | Default (Range)          |
|------------------------|-------------------|--|--------------------------|
| b5-03<br>(01A7)<br>RUN | Integral Time (I) | <b>V/f</b> <b>CL-V/f</b> <b>OLV</b> <b>CLV</b> <b>AOLV</b> <b>OLV/PM</b> <b>AOLV/PM</b> <b>CLV/PM</b> <b>EZOLV</b><br>Sets the integral time (I) that is applied to PID input. | 1.0 s<br>(0.0 - 360.0 s) |

Set a short integral time in *b5-03* to remove the offset more quickly. If the integral time is too short, overshoot or oscillation can occur.

Set *b5-03 = 0.00* to disable I control.

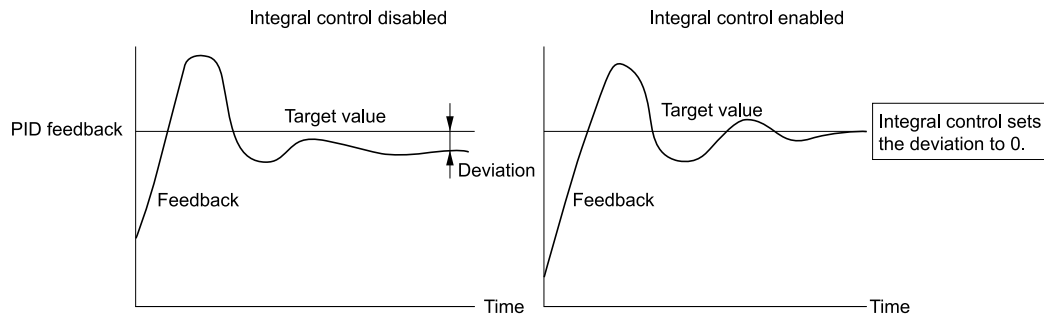


Figure 2.39 Integral Time and Deviation

### ■ b5-04: Integral Limit

| No. (Hex.)             | Name           | Description  | Default (Range)          |
|------------------------|----------------|--|--------------------------|
| b5-04<br>(01A8)<br>RUN | Integral Limit | <b>V/f</b> <b>CL-V/f</b> <b>OLV</b> <b>CLV</b> <b>AOLV</b> <b>OLV/PM</b> <b>AOLV/PM</b> <b>CLV/PM</b> <b>EZOLV</b><br>Sets the upper limit for integral control (I) as a percentage of the Maximum Output Frequency. | 100.0%<br>(0.0 - 100.0%) |

Applications with loads that quickly change will cause the output of the PID function to oscillate. Set this parameter to a low value to prevent oscillation, mechanical loss, and motor speed loss.

### ■ b5-05: Derivative Time (D)

| No. (Hex.)             | Name                | Description   | Default (Range)            |
|------------------------|---------------------|---|----------------------------|
| b5-05<br>(01A9)<br>RUN | Derivative Time (D) | <b>V/f</b> <b>CL-V/f</b> <b>OLV</b> <b>CLV</b> <b>AOLV</b> <b>OLV/PM</b> <b>AOLV/PM</b> <b>CLV/PM</b> <b>EZOLV</b><br>Sets the derivative time (D) for PID control. This parameter adjusts system responsiveness. | 0.00 s<br>(0.00 - 10.00 s) |

Increasing the time setting increases controller responsiveness but possibly causes vibrations. Decreasing the time setting suppresses overshoot but decreases controller responsiveness.

Set *b5-05* = 0.00 to disable D control.

### ■ b5-06: PID Output Limit

| No. (Hex.)             | Name             | Description   | Default (Range)          |
|------------------------|------------------|---|--------------------------|
| b5-06<br>(01AA)<br>RUN | PID Output Limit | <b>V/f</b> <b>CL-V/f</b> <b>OLV</b> <b>CLV</b> <b>AOLV</b> <b>OLV/PM</b> <b>AOLV/PM</b> <b>CLV/PM</b> <b>EZOLV</b><br>Sets the maximum possible output from the PID controller as a percentage of the Maximum Output Frequency. | 100.0%<br>(0.0 - 100.0%) |

### ■ b5-07: PID Offset Adjustment

| No. (Hex.)             | Name                  | Description   | Default (Range)            |
|------------------------|-----------------------|---|----------------------------|
| b5-07<br>(01AB)<br>RUN | PID Offset Adjustment | <b>V/f</b> <b>CL-V/f</b> <b>OLV</b> <b>CLV</b> <b>AOLV</b> <b>OLV/PM</b> <b>AOLV/PM</b> <b>CLV/PM</b> <b>EZOLV</b><br>Sets the offset for the PID control output as a percentage of the Maximum Output Frequency. | 0.0%<br>(-100.0 - +100.0%) |

### ■ b5-08: PID Primary Delay Time Constant

| No. (Hex.)                       | Name                            | Description  | Default (Range)            |
|----------------------------------|---------------------------------|--|----------------------------|
| b5-08<br>(01AC)<br>RUN<br>Expert | PID Primary Delay Time Constant | <b>V/f</b> <b>CL-V/f</b> <b>OLV</b> <b>CLV</b> <b>AOLV</b> <b>OLV/PM</b> <b>AOLV/PM</b> <b>CLV/PM</b> <b>EZOLV</b><br>Sets the primary delay time constant for the PID control output. Usually it is not necessary to change this setting. | 0.00 s<br>(0.00 - 10.00 s) |

Prevents resonance if there is a large quantity of mechanical friction or if rigidity is unsatisfactory. Set the value larger than the resonant frequency cycle. A value that is too large will decrease drive responsiveness.

### ■ b5-09: PID Output Level Selection

| No. (Hex.)      | Name                       | Description  | Default (Range) |
|-----------------|----------------------------|--|-----------------|
| b5-09<br>(01AD) | PID Output Level Selection | <b>V/f</b> <b>CL-V/f</b> <b>OLV</b> <b>CLV</b> <b>AOLV</b> <b>OLV/PM</b> <b>AOLV/PM</b> <b>CLV/PM</b> <b>EZOLV</b><br>Sets the polarity of the PID output. | 0<br>(0, 1)     |

Use this parameter in applications that decrease the drive output frequency when you increase the PID setpoint.

#### 0 : Normal Output (Direct Acting)

A positive PID input increases the PID output (direct acting).

#### 1 : Reverse Output (Reverse Acting)

A positive PID input decreases the PID output (reverse acting).

### ■ b5-10: PID Output Gain Setting

| No. (Hex.)             | Name                    | Description   | Default (Range)        |
|------------------------|-------------------------|---|------------------------|
| b5-10<br>(01AE)<br>RUN | PID Output Gain Setting | <b>V/f</b> <b>CL-V/f</b> <b>OLV</b> <b>CLV</b> <b>AOLV</b> <b>OLV/PM</b> <b>AOLV/PM</b> <b>CLV/PM</b> <b>EZOLV</b><br>Sets the amount of gain to apply to the PID output. | 1.00<br>(0.00 - 25.00) |

## 2.3 b: Application

Applies a gain to the PID output and can help when  $b5-01 = 3$  or  $4$  [*PID Mode Setting = Fref + PID Trim, Fref + PID Trim (D on feedback)*].

### ■ b5-11: PID Output Reverse Selection

| No. (Hex.)   | Name                         | Description  | Default (Range) |
|--------------|------------------------------|--|-----------------|
| b5-11 (01AF) | PID Output Reverse Selection | <div style="display: flex; gap: 5px;"> <span>V/f</span> <span>CL-V/f</span> <span>OLV</span> <span>CLV</span> <span>AOLV</span> <span>OLV/PM</span> <span>AOLV/PM</span> <span>CLV/PM</span> <span>EZOLV</span> </div> Sets the function that enables and disables reverse motor rotation for negative PID control output. | 0<br>(0, 1)     |

This parameter is disabled when  $b5-01 = 3, 4$  [*PID Mode Setting = Fref + PID Trim, Fref + PID Trim (D on feedback)*]. There is no limit for PID output (PID output can be positive or negative). Operates the same as setting “1: Enabled: Negative lower limit”.

#### 0 : Lower Limit is Zero

When PID output is negative, PID output is limited to 0 and drive output is shut off.

#### 1 : Negative Output Accepted

When the PID output is negative, the motor will rotate in reverse. If  $b1-04 = 1$  [*Reverse Operation Selection = Reverse Disabled*], the lower limit is 0.

### ■ b5-12: Feedback Loss Detection Select

| No. (Hex.)   | Name                           | Description  | Default (Range) |
|--------------|--------------------------------|--|-----------------|
| b5-12 (01B0) | Feedback Loss Detection Select | <div style="display: flex; gap: 5px;"> <span>V/f</span> <span>CL-V/f</span> <span>OLV</span> <span>CLV</span> <span>AOLV</span> <span>OLV/PM</span> <span>AOLV/PM</span> <span>CLV/PM</span> <span>EZOLV</span> </div> Sets the drive response to PID Feedback Low/High. Sets drive operation after the drive detects PID feedback Low/High. | 0<br>(0 - 5)    |

#### 0 : Digital Out Only, Always Detect

The MFDO terminal set for *PID Feedback Low* or *PID Feedback High* [ $H2-01$  to  $H2-03 = 3E, 3F$ ] activates. When the drive detects Feedback Low/High, the keypad will not show an alarm and the drive will continue operation.

When the feedback signal is less than the level set in  $b5-13$  [*PID Feedback Loss Detection Lvl*] for longer than the time set in  $b5-14$  [*PID Feedback Loss Detection Time*], the MFDO terminal set for a *PID Feedback Low* activates.

When the feedback signal is more than the level set in  $b5-36$  [*PID High Feedback Detection Lvl*] for longer than the time set in  $b5-37$  [*PID High Feedback Detection Time*] the MFDO terminal set for a *PID Feedback High* activates.

When the feedback value is not in the detection range, the drive resets the MFDO.

#### 1 : Alarm + Digital Out, Always Det

The drive detects *FbL* [*PID Feedback Loss*] and *FbH* [*Excessive PID Feedback*]. The MFDO terminal set for *PID Feedback Low* or *PID Feedback High* [ $H2-01$  to  $H2-03 = 3E, 3F$ ] activates. The output terminal set for *Alarm* [ $H2-01$  to  $H2-03 = 10$ ] activates and the drive continues operation.

When the feedback signal is less than the level set in  $b5-13$  for longer than the time set in  $b5-14$ , the MFDO terminal set for a *PID Feedback Low* activates.

When the feedback signal is less than the level set in  $b5-36$  for longer than the time set in  $b5-37$ , the MFDO terminal set for a *PID Feedback High* activates.

When the feedback value is not in the detection range, the drive resets the MFDO.

#### 2 : Fault + Digital Out, Always Det

The drive detects *FbL* and *FbH*. Fault relay output terminal MA-MC turns ON, MB-MC turns OFF, and the drive coasts to stop.

When the feedback signal is less than the level set in  $b5-13$  for the time set in  $b5-14$ , the drive detects *FbL*.

When the feedback signal is less than the level set in  $b5-36$  for the time set in  $b5-37$ , the drive detects *FbH*.

#### 3 : Digital Out Only, @PID Enable

The MFDO terminal set for *PID Feedback Low* or *PID Feedback High* activates. The keypad will not show an alarm. The drive continues operation.

When the MFDI terminal set to *PID Disable* [ $H1-xx = 19$ ] activates, the drive disables fault detection.

#### 4 : Alarm + Digital Out, @PID Enable

The drive detects *FbL* and *FbH*. The MFDO terminal set for *PID Feedback Low* or *PID Feedback High* activates. The output terminal set for *Alarm [H2-01 to H2-03 = 10]* activates and the drive continues operation.

When the MFDI terminal set to *PID Disable [H1-xx = 19]* activates, the drive disables fault detection.

### 5 : Fault + Digital Out, @PID Enable

The drive detects *FbL* and *FbH*. Fault relay output terminal MA-MC turns ON, MB-MC turns OFF, and the drive coasts to stop.

When the MFDI terminal set to *PID Disable [H1-xx = 19]* activates, the drive disables fault detection.

#### ■ b5-13: PID Feedback Loss Detection Lvl

| No. (Hex.)      | Name                            | Description  | Default (Range)  |
|-----------------|---------------------------------|--|------------------|
| b5-13<br>(01B1) | PID Feedback Loss Detection Lvl | <div style="display: flex; justify-content: space-between; gap: 5px;"> <span>V/f</span> <span>CL-V/f</span> <span>OLV</span> <span>CLV</span> <span>AOLV</span> <span>OLV/PM</span> <span>AOLV/PM</span> <span>CLV/PM</span> <span>EZOLV</span> </div> <p>Sets the level that triggers <i>PID Feedback Loss [FbL]</i> detection as a percentage of the Maximum Output Frequency.</p> | 0%<br>(0 - 100%) |

The drive detects *PID Feedback Loss [FbL]* when the feedback signal decreases to less than the level set in *b5-13* for longer than the time set in *b5-14 [PID Feedback Loss Detection Time]*.

#### ■ b5-14: PID Feedback Loss Detection Time

| No. (Hex.)      | Name                             | Description  | Default (Range)         |
|-----------------|----------------------------------|--|-------------------------|
| b5-14<br>(01B2) | PID Feedback Loss Detection Time | <div style="display: flex; justify-content: space-between; gap: 5px;"> <span>V/f</span> <span>CL-V/f</span> <span>OLV</span> <span>CLV</span> <span>AOLV</span> <span>OLV/PM</span> <span>AOLV/PM</span> <span>CLV/PM</span> <span>EZOLV</span> </div> <p>Sets the length of time that PID Feedback must be less than <i>b5-13 [PID Feedback Loss Detection Lvl]</i> to detect <i>PID Feedback Loss [FbL]</i>.</p> | 1.0 s<br>(0.0 - 25.5 s) |

#### ■ b5-15: PID Sleep Function Start Level

| No. (Hex.)      | Name                           | Description   | Default (Range)                      |
|-----------------|--------------------------------|---|--------------------------------------|
| b5-15<br>(01B3) | PID Sleep Function Start Level | <div style="display: flex; justify-content: space-between; gap: 5px;"> <span>V/f</span> <span>CL-V/f</span> <span>OLV</span> <span>CLV</span> <span>AOLV</span> <span>OLV/PM</span> <span>AOLV/PM</span> <span>CLV/PM</span> <span>EZOLV</span> </div> <p>Sets the output level that triggers the PID Sleep function.</p> | Determined by A1-02<br>(0.0 - 590.0) |

The drive goes into Sleep mode when the PID output or frequency reference is less than *b5-15* for longer than the time set to *b5-16 [PID Sleep Delay Time]*. The drive continues operation when the PID output or frequency reference is more than *b5-15* for longer than the time set to *b5-16*.

#### ■ b5-16: PID Sleep Delay Time

| No. (Hex.)      | Name                 | Description  | Default (Range)         |
|-----------------|----------------------|--|-------------------------|
| b5-16<br>(01B4) | PID Sleep Delay Time | <div style="display: flex; justify-content: space-between; gap: 5px;"> <span>V/f</span> <span>CL-V/f</span> <span>OLV</span> <span>CLV</span> <span>AOLV</span> <span>OLV/PM</span> <span>AOLV/PM</span> <span>CLV/PM</span> <span>EZOLV</span> </div> <p>Sets a delay time to start or stop the PID Sleep function.</p> | 0.0 s<br>(0.0 - 25.5 s) |

#### ■ b5-17: PID Accel/Decel Time

| No. (Hex.)             | Name                 | Description  | Default (Range)           |
|------------------------|----------------------|--|---------------------------|
| b5-17<br>(01B5)<br>RUN | PID Accel/Decel Time | <div style="display: flex; justify-content: space-between; gap: 5px;"> <span>V/f</span> <span>CL-V/f</span> <span>OLV</span> <span>CLV</span> <span>AOLV</span> <span>OLV/PM</span> <span>AOLV/PM</span> <span>CLV/PM</span> <span>EZOLV</span> </div> <p>Raises or lowers the PID setpoint using the acceleration and deceleration times set to the drive. This is a soft-starter for the PID setpoint.</p> | 0.0 s<br>(0.0 - 6000.0 s) |

The drive usually uses the acceleration and deceleration times set in *CI-xx [Accel and Decel Times]*, but when PID control is enabled, the drive applies *CI-xx* after PID output. If you frequently change the PID setpoint, the drive responsiveness decreases. When resonance with PID control causes hunting, overshoot, or undershoot, set *b5-17* for longer acceleration and deceleration times.

Decrease *CI-xx* until hunting stops, then use *b5-17* to check the acceleration and deceleration. To enable and disable the setting in *b5-17* through an MFDI terminal, set *PID Soft Starter Disable [H1-xx = 34]*.

## 2.3 b: Application

### ■ b5-18: b5-19 PID Setpoint Selection

| No.<br>(Hex.)   | Name                   | Description  | Default<br>(Range) |
|-----------------|------------------------|--|--------------------|
| b5-18<br>(01DC) | PID Setpoint Selection | <b>V/f</b> <b>CL-V/f</b> <b>OLV</b> <b>CLV</b> <b>AOLV</b> <b>OLV/PM</b> <b>AOLV/PM</b> <b>CLV/PM</b> <b>EZOLV</b><br>Sets the function that enables and disables <i>b5-19</i> [PID Setpoint Value]. | 0<br>(0, 1)        |

#### 0 : Disabled

The drive does not use the value set in *b5-19* as the PID setpoint.

#### 1 : Enabled

The drive uses the value set in *b5-19* as the PID setpoint.

### ■ b5-19: PID Setpoint Value

| No.<br>(Hex.)          | Name         | Description   | Default<br>(Range)        |
|------------------------|--------------|---|---------------------------|
| b5-19<br>(01DD)<br>RUN | PID Setpoint | <b>V/f</b> <b>CL-V/f</b> <b>OLV</b> <b>CLV</b> <b>AOLV</b> <b>OLV/PM</b> <b>AOLV/PM</b> <b>CLV/PM</b> <b>EZOLV</b><br>Sets the PID setpoint when <i>b5-18</i> = 1 [PID Setpoint Selection = Enabled]. | 0.00%<br>(0.00 - 100.00%) |

### ■ b5-20: PID Unit Selection

| No.<br>(Hex.)   | Name               | Description   | Default<br>(Range) |
|-----------------|--------------------|---|--------------------|
| b5-20<br>(01E2) | PID Unit Selection | <b>V/f</b> <b>CL-V/f</b> <b>OLV</b> <b>CLV</b> <b>AOLV</b> <b>OLV/PM</b> <b>AOLV/PM</b> <b>CLV/PM</b> <b>EZOLV</b><br>Sets the number of digits to set and show the PID setpoint. | 1<br>(0 - 3)       |

Set the units for the following parameters and monitors.

- b5-19 [PID Setpoint Value]
- b5-58 [PID Setpoint2]
- b5-59 [PID Setpoint3]
- b5-60 [PID Setpoint4]
- U5-01 [PID Feedback]
- U5-04 [PID Setpoint]
- U5-99 [PID Setpoint Command]

#### 0 : 0.01Hz units

The drive uses 0.01 Hz units.

#### 1 : 0.01% units

The drive uses 0.01% units. Set the value as a percentage of *E1-04* [Maximum Output Frequency].

#### 2 : rev/min

The drive uses 1 rev/min unit. Set *E2-04*, *E4-04*, or *E5-04* [Motor Pole Count].

#### 3 : User Units

The drive uses units set in *b5-38* [PID User Unit Display Scaling] and *b5-39* [PID User Unit Display Digits] to show the PID setpoint in *U5-01*, *U5-04*, *U5-06* [PID Feedback, PID Setpoint, PID Fdbk-Diff PID Fdbk].

### ■ b5-34: PID Output Lower Limit Level

| No.<br>(Hex.)          | Name                         | Description  | Default<br>(Range)         |
|------------------------|------------------------------|--|----------------------------|
| b5-34<br>(019F)<br>RUN | PID Output Lower Limit Level | <b>V/f</b> <b>CL-V/f</b> <b>OLV</b> <b>CLV</b> <b>AOLV</b> <b>OLV/PM</b> <b>AOLV/PM</b> <b>CLV/PM</b> <b>EZOLV</b><br>Sets the output lower limit for the PID control as a percentage of the Maximum Output Frequency. | 0.0%<br>(-100.0 - +100.0%) |

Use a lower limit to keep PID control output from dropping below a fixed level.

Set this parameter to 0.0% to disable this function.

### ■ b5-35: PID Input Limit Level

| No. (Hex.)             | Name                  | Description  | Default (Range)            |
|------------------------|-----------------------|--|----------------------------|
| b5-35<br>(01A0)<br>RUN | PID Input Limit Level | <b>V/f</b> <b>CL-V/f</b> <b>OLV</b> <b>CLV</b> <b>AOLV</b> <b>OLV/PM</b> <b>AOLV/PM</b> <b>CLV/PM</b> <b>EZOLV</b><br>Sets the output upper limit for the PID control as a percentage of the Maximum Output Frequency. | 1000.0%<br>(0.0 - 1000.0%) |

A large input value for PID control makes a high output. The drive applies this limit to the negative and positive domains.

### ■ b5-36: PID High Feedback Detection Lvl

| No. (Hex.)      | Name                            | Description   | Default (Range)    |
|-----------------|---------------------------------|---|--------------------|
| b5-36<br>(01A1) | PID High Feedback Detection Lvl | <b>V/f</b> <b>CL-V/f</b> <b>OLV</b> <b>CLV</b> <b>AOLV</b> <b>OLV/PM</b> <b>AOLV/PM</b> <b>CLV/PM</b> <b>EZOLV</b><br>Sets the level that triggers <i>Excessive PID Feedback [FbH]</i> as a percentage of the Maximum Output Frequency. | 100%<br>(0 - 100%) |

When the feedback signal increases to more than the level set in *b5-36* for the time set in *b5-37* [*PID High Feedback Detection Time*], the drive will detect *Excessive PID Feedback [FbH]*.

### ■ b5-37: PID High Feedback Detection Time

| No. (Hex.)      | Name                             | Description  | Default (Range)         |
|-----------------|----------------------------------|--|-------------------------|
| b5-37<br>(01A2) | PID High Feedback Detection Time | <b>V/f</b> <b>CL-V/f</b> <b>OLV</b> <b>CLV</b> <b>AOLV</b> <b>OLV/PM</b> <b>AOLV/PM</b> <b>CLV/PM</b> <b>EZOLV</b><br>Sets the length of time that the PID feedback signal must be more than the level set in <i>b5-36</i> [ <i>PID Feedback High Detection Lvl</i> ] to cause <i>Excessive PID Feedback [FbH]</i> . | 1.0 s<br>(0.0 - 25.5 s) |

### ■ b5-38: PID User Unit Display Scaling

| No. (Hex.)      | Name                          | Description   | Default (Range)                    |
|-----------------|-------------------------------|---|------------------------------------|
| b5-38<br>(01FE) | PID User Unit Display Scaling | <b>V/f</b> <b>CL-V/f</b> <b>OLV</b> <b>CLV</b> <b>AOLV</b> <b>OLV/PM</b> <b>AOLV/PM</b> <b>CLV/PM</b> <b>EZOLV</b><br>Sets the value that the drive sets or shows as the PID setpoint when at the maximum output frequency. | Determined by b5-20<br>(1 - 60000) |

The drive uses this parameter and *b5-39* [*PID Setpoint Display Digits*] together.

When *b5-20* = 3 [*PID Unit Selection = User Units*], the drive applies user-set PID setpoint and display units to the following parameters and monitors.

- b5-19 [PID Setpoint Value]
- b5-58 [PID Setpoint2]
- b5-59 [PID Setpoint3]
- b5-60 [PID Setpoint4]
- U5-01 [PID Feedback]
- U5-04 [PID Setpoint]
- U5-99 [PID Setpoint Command]

### ■ b5-39: PID User Unit Display Digits

| No. (Hex.)      | Name                         | Description   | Default (Range)                |
|-----------------|------------------------------|---|--------------------------------|
| b5-39<br>(01FF) | PID User Unit Display Digits | <b>V/f</b> <b>CL-V/f</b> <b>OLV</b> <b>CLV</b> <b>AOLV</b> <b>OLV/PM</b> <b>AOLV/PM</b> <b>CLV/PM</b> <b>EZOLV</b><br>Sets the number of digits to set and show the PID setpoint. | Determined by b5-20<br>(0 - 3) |

The drive uses this parameter and *b5-38* [*PID Setpoint User Display*] together.

When *b5-20* = 3 [*PID Unit Selection = User Units*], the drive applies user-set PID setpoint and display units to the following parameters and monitors.

- b5-19 [PID Setpoint Value]
- b5-58 [PID Setpoint2]

## 2.3 b: Application

- b5-59 [PID Setpoint3]
- b5-60 [PID Setpoint4]
- U5-01 [PID Feedback]
- U5-04 [PID Setpoint]
- U5-99 [PID Setpoint Command]

**0 : No Decimal Places (XXXXX)**

**1 : One Decimal Places (XXXX.X)**

**2 : Two Decimal Places (XXX.XX)**

**3 : Three Decimal Places (XX.XXX)**

### ■ b5-40: Frequency Reference Monitor @PID

| No. (Hex.)      | Name                             | Description  | Default (Range) |
|-----------------|----------------------------------|--|-----------------|
| b5-40<br>(017F) | Frequency Reference Monitor @PID | <b>V/f</b> <b>CL-V/f</b> <b>OLV</b> <b>CLV</b> <b>AOLV</b> <b>OLV/PM</b> <b>AOLV/PM</b> <b>CLV/PM</b> <b>EZOLV</b><br>Sets the contents for monitor <i>U1-01</i> [Frequency Reference] in PID control. | 0<br>(0, 1)     |

**0 : U1-01 Includes PID Output**

Monitor *U1-01* shows the frequency reference that was increased or decreased by the PID output.

**1 : U1-01 Excludes PID Output**

Monitor *U1-01* shows the actual frequency reference.

### ■ b5-47: PID Trim Mode Output Reverse Sel

| No. (Hex.)      | Name                             | Description   | Default (Range) |
|-----------------|----------------------------------|---|-----------------|
| b5-47<br>(017D) | PID Trim Mode Output Reverse Sel | <b>V/f</b> <b>CL-V/f</b> <b>OLV</b> <b>CLV</b> <b>AOLV</b> <b>OLV/PM</b> <b>AOLV/PM</b> <b>CLV/PM</b> <b>EZOLV</b><br>Sets whether or not the motor should rotate in reverse when the PID control output is negative. | 1<br>(0, 1)     |

This parameter is enabled when  $b5-01 = 3$  or  $4$  [PID Function Setting =  $Fref+PID D=Fdbk$ ,  $Fref+PID D=Fdfwd$ ].

**0 : Lower Limit is Zero**

When PID output is negative, PID output is limited to 0 and drive output is shut off.

**1 : Negative Output Accepted**

When the PID output is negative, the motor will rotate in reverse.

### ■ b5-53: PID Integrator Ramp Limit

| No. (Hex.)             | Name                      | Description   | Default (Range)           |
|------------------------|---------------------------|---|---------------------------|
| b5-53<br>(0B8F)<br>RUN | PID Integrator Ramp Limit | <b>V/f</b> <b>CL-V/f</b> <b>OLV</b> <b>CLV</b> <b>AOLV</b> <b>OLV/PM</b> <b>AOLV/PM</b> <b>CLV/PM</b> <b>EZOLV</b><br>Sets the responsiveness of PID control when the PID feedback changes quickly. | 0.0 Hz<br>(0.0 - 10.0 Hz) |

**Note:**

- This parameter is disabled when set to 0.0 Hz.
- When the integrator ramp limit is enabled ( $b5-53 > 0.0$  Hz), the PID integrator value limit is the range set by the output frequency  $\pm b5-53$ .
- When the PID feedback changes quickly, gradually decrease the value of this parameter in increments of 0.1 Hz to decrease the speed of the response of PID control.

### ■ b5-55: PID Feedback Monitor Selection

| No. (Hex.)      | Name                           | Description  | Default (Range)    |
|-----------------|--------------------------------|--|--------------------|
| b5-55<br>(0BE1) | PID Feedback Monitor Selection | <b>V/f</b> <b>CL-V/f</b> <b>OLV</b> <b>CLV</b> <b>AOLV</b> <b>OLV/PM</b> <b>AOLV/PM</b> <b>CLV/PM</b> <b>EZOLV</b><br>Selects the monitor ( <i>Ux-xx</i> ) used as the PID Feedback. Set the <i>x-xx</i> part of the <i>Ux-xx</i> [Monitor]. | 000<br>(000 - 999) |

**Note:**

- You cannot select *parameter U5-xx*.
- This parameter is disabled when set to 000.



### ■ b5-56: PID Feedback Monitor Gain

| No. (Hex.)      | Name                      | Description  | Default (Range)        |
|-----------------|---------------------------|--|------------------------|
| b5-56<br>(0BE2) | PID Feedback Monitor Gain | <b>V/f</b> <b>CL-V/f</b> <b>OLV</b> <b>CLV</b> <b>AOLV</b> <b>OLV/PM</b> <b>AOLV/PM</b> <b>CLV/PM</b> <b>EZOLV</b><br>Sets the gain for the monitor specified in b5-55 [PID Feedback Monitor Selection]. | 1.00<br>(0.00 - 10.00) |

### ■ b5-57: PID Feedback Monitor Bias

| No. (Hex.)      | Name                      | Description  | Default (Range)           |
|-----------------|---------------------------|--|---------------------------|
| b5-57<br>(11DD) | PID Feedback Monitor Bias | <b>V/f</b> <b>CL-V/f</b> <b>OLV</b> <b>CLV</b> <b>AOLV</b> <b>OLV/PM</b> <b>AOLV/PM</b> <b>CLV/PM</b> <b>EZOLV</b><br>Sets the bias for the monitor specified in b5-55 [PID Feedback Monitor Selection]. | 0.00<br>(-10.00 - +10.00) |

### ■ b5-58 to b5-60: PID Setpoints 2 to 4

| No. (Hex.)                              | Name                 | Description  | Default (Range)           |
|---|----------------------|--|---------------------------|
| b5-58 to b5-60:<br>(1182 - 1184)<br>RUN | PID Setpoints 2 to 4 | <b>V/f</b> <b>CL-V/f</b> <b>OLV</b> <b>CLV</b> <b>AOLV</b> <b>OLV/PM</b> <b>AOLV/PM</b> <b>CLV/PM</b> <b>EZOLV</b><br>Sets the PID setpoint when H1-xx = 3E or 3F [MFDI Function Select = PID Setpoint Selection 1/2]. This value is a percentage of the maximum output frequency. | 0.00%<br>(0.00 - 100.00%) |

Table 2.28 shows how the different MFDI H1-xx values (3E and 3F) have an effect on the PID setpoint value.

Table 2.28 Switching of MFDI and PID Setpoint Value

| H1-xx = 3E | H1-xx = 3F | PID Setpoint Value    |
|------------|------------|-----------------------|
| OFF        | OFF        | No switch             |
| ON         | OFF        | b5-58 [PID Setpoint2] |
| OFF        | ON         | b5-59 [PID Setpoint3] |
| ON         | ON         | b5-60 [PID Setpoint4] |

### ■ b5-61: PID Trim Mode Lower Limit Sel

| No. (Hex.)      | Name                          | Description   | Default (Range) |
|-----------------|-------------------------------|---|-----------------|
| b5-61<br>(119A) | PID Trim Mode Lower Limit Sel | <b>V/f</b> <b>CL-V/f</b> <b>OLV</b> <b>CLV</b> <b>AOLV</b> <b>OLV/PM</b> <b>AOLV/PM</b> <b>CLV/PM</b> <b>EZOLV</b><br>Sets the function that adjusts the PID output in relation to the frequency reference. | 0<br>(0, 1)     |

#### 0 : No

Does not adjust the PID output with the frequency reference.

#### 1 : Yes

Adjusts the PID output in relation to the frequency reference. The setting value of b5-62 [PID Trim Mode Lower Limit Value] sets the lower limit of the post-adjustment value. The maximum output frequency sets the upper limit.

#### Note:

- Set b5-01 = 3, 4, 7, or 8 to enable this parameter.
- When b5-61 = 1, you can use this formula to adjust PID output proportional to the frequency reference:

$$U5-03 = U5-03 \times \left| \frac{F_{ref}}{F_{max}} \right|^{*1}$$

U5-03 [PID Output], Fref [Frequency Reference], and Fmax [Maximum Output Frequency]

\*1 Lower limit = b5-62, Upper limit = Maximum output frequency

### ■ b5-62: PID Trim Mode Lower Limit Value

| No. (Hex.)      | Name                            | Description   | Default (Range)           |
|-----------------|---------------------------------|---|---------------------------|
| b5-62<br>(119B) | PID Trim Mode Lower Limit Value | <b>V/f</b> <b>CL-V/f</b> <b>OLV</b> <b>CLV</b> <b>AOLV</b> <b>OLV/PM</b> <b>AOLV/PM</b> <b>CLV/PM</b> <b>EZOLV</b><br>Sets the PID Trim Mode Lower Limit Value as a percentage of the maximum output frequency. | 0.00%<br>(0.00 - 100.00%) |

## 2.3 b: Application

**Note:**

Set *b5-01* = 3, 4, 7, or 8 to enable this parameter.

### ■ b5-63: PID Differential FB Monitor Sel

| No. (Hex.)   | Name                            | Description   | Default (Range)    |
|--------------|---------------------------------|---|--------------------|
| b5-63 (119C) | PID Differential FB Monitor Sel | <div style="display: flex; gap: 5px;"> <span>V/f</span> <span>CL-V/f</span> <span>OLV</span> <span>CLV</span> <span>AOLV</span> <span>OLV/PM</span> <span>AOLV/PM</span> <span>CLV/PM</span> <span>EZOLV</span> </div> <p>Selects the monitor (<i>Ux-xx</i>) used as the PID Differential Feedback. Set the <i>x-xx</i> part of the <i>Ux-xx</i> [Monitor].</p> | 000<br>(000 - 999) |

**Note:**

- You cannot select *parameter U5-xx*.
- This parameter is disabled when set to 000.

### ■ b5-64: PID Differential FB Monitor Gain

| No. (Hex.)   | Name                             | Description  | Default (Range)        |
|--------------|----------------------------------|--|------------------------|
| b5-64 (119D) | PID Differential FB Monitor Gain | <div style="display: flex; gap: 5px;"> <span>V/f</span> <span>CL-V/f</span> <span>OLV</span> <span>CLV</span> <span>AOLV</span> <span>OLV/PM</span> <span>AOLV/PM</span> <span>CLV/PM</span> <span>EZOLV</span> </div> <p>Sets the gain for the monitor specified in <i>b5-63</i> [PID Differential FB Monitor Sel].</p> | 1.00<br>(0.00 - 10.00) |

### ■ b5-65: PID Differential FB Monitor Bias

| No. (Hex.)   | Name                             | Description  | Default (Range)           |
|--------------|----------------------------------|--|---------------------------|
| b5-65 (119F) | PID Differential FB Monitor Bias | <div style="display: flex; gap: 5px;"> <span>V/f</span> <span>CL-V/f</span> <span>OLV</span> <span>CLV</span> <span>AOLV</span> <span>OLV/PM</span> <span>AOLV/PM</span> <span>CLV/PM</span> <span>EZOLV</span> </div> <p>Sets the bias for the monitor specified in <i>b5-63</i> [PID Differential FB Monitor Sel].</p> | 0.00<br>(-10.00 - +10.00) |

### ■ b5-66: PID Feedback Monitor Level

| No. (Hex.)   | Name                       | Description   | Default (Range) |
|--------------|----------------------------|---|-----------------|
| b5-66 (11DE) | PID Feedback Monitor Level | <div style="display: flex; gap: 5px;"> <span>V/f</span> <span>CL-V/f</span> <span>OLV</span> <span>CLV</span> <span>AOLV</span> <span>OLV/PM</span> <span>AOLV/PM</span> <span>CLV/PM</span> <span>EZOLV</span> </div> <p>Sets the signal level for the monitor specified in <i>b5-55</i> [PID Feedback Monitor Selection].</p> | 0<br>(0, 1)     |

0 : Absolute

1 : Bi-directional (+/-)

### ■ b5-67: PID Differential FB Monitor Lvl

| No. (Hex.)   | Name                            | Description  | Default (Range) |
|--------------|---------------------------------|--|-----------------|
| b5-67 (11DF) | PID Differential FB Monitor Lvl | <div style="display: flex; gap: 5px;"> <span>V/f</span> <span>CL-V/f</span> <span>OLV</span> <span>CLV</span> <span>AOLV</span> <span>OLV/PM</span> <span>AOLV/PM</span> <span>CLV/PM</span> <span>EZOLV</span> </div> <p>Sets the signal level for the monitor specified in <i>b5-63</i> [PID Differential FB Monitor Sel].</p> | 0<br>(0, 1)     |

0 : Absolute

1 : Bi-directional (+/-)

### ■ b5-89: Sleep Method Selection

| No. (Hex.)          | Name                   | Description  | Default (Range) |
|---------------------|------------------------|--|-----------------|
| b5-89 (0B89)<br>RUN | Sleep Method Selection | <div style="display: flex; gap: 5px;"> <span>V/f</span> <span>CL-V/f</span> <span>OLV</span> <span>CLV</span> <span>AOLV</span> <span>OLV/PM</span> <span>AOLV/PM</span> <span>CLV/PM</span> <span>EZOLV</span> </div> <p>Sets sleep and wake up operation when using PID.</p> | 0<br>(0, 1)     |

0 : Standard

1 : EZ Sleep/Wake-up

### ■ b5-90: EZ Sleep Unit

| No. (Hex.)      | Name          | Description   | Default (Range) |
|-----------------|---------------|---|-----------------|
| b5-90<br>(0B90) | EZ Sleep Unit | <b>V/f</b> <b>CL-V/f</b> <b>OLV</b> <b>CLV</b> <b>AOLV</b> <b>OLV/PM</b> <b>AOLV/PM</b> <b>CLV/PM</b> <b>EZOLV</b><br>Sets the measurement units for b5-91 [EZ Sleep Minimum Speed] and b5-92 [EZ Sleep Level]. | 0<br>(0, 1)     |

0 : 0.1Hz units

1 : rev/min

### ■ b5-91: EZ Sleep Minimum Speed

| No. (Hex.)             | Name                   | Description   | Default (Range)  |
|------------------------|------------------------|---|--|
| b5-91<br>(0B91)<br>RUN | EZ Sleep Minimum Speed | <b>V/f</b> <b>CL-V/f</b> <b>OLV</b> <b>CLV</b> <b>AOLV</b> <b>OLV/PM</b> <b>AOLV/PM</b> <b>CLV/PM</b> <b>EZOLV</b><br>Sets the minimum speed for the EZ Sleep/Wakeup function. This parameter uses the largest value from b5-91, b5-34 [PID Output Lower Limit Level], and d2-02 [Frequency Reference Lower Limit]. | 0.0 Hz or 0 min <sup>-1</sup> (r/min)<br>(0.0 to 590.0 Hz or 0 to 35400 min <sup>-1</sup> (r/min)) |

**Note:**

The value of b5-90 [EZ Sleep Unit] sets the units. When b5-90 changes, this parameter does not automatically update. Set this parameter again after you change b5-90 is changed.

### ■ b5-92: EZ Sleep Level

| No. (Hex.)             | Name           | Description  | Default (Range)  |
|------------------------|----------------|--|--|
| b5-92<br>(0B92)<br>RUN | EZ Sleep Level | <b>V/f</b> <b>CL-V/f</b> <b>OLV</b> <b>CLV</b> <b>AOLV</b> <b>OLV/PM</b> <b>AOLV/PM</b> <b>CLV/PM</b> <b>EZOLV</b><br>Sets the value that the output frequency or motor speed must be less than b5-93 [EZ Sleep Time] to enter Sleep Mode. | 0.0 Hz or 0 min <sup>-1</sup> (r/min)<br>(0.0 to 590.0 Hz or 0 to 35400 min <sup>-1</sup> (r/min)) |

**Note:**

When b5-90 [EZ Sleep Unit] changes, this parameter does not automatically update. Set this parameter again after you change b5-90.

### ■ b5-93: EZ Sleep Time

| No. (Hex.)             | Name          | Description  | Default (Range)           |
|------------------------|---------------|--|---------------------------|
| b5-93<br>(0B93)<br>RUN | EZ Sleep Time | <b>V/f</b> <b>CL-V/f</b> <b>OLV</b> <b>CLV</b> <b>AOLV</b> <b>OLV/PM</b> <b>AOLV/PM</b> <b>CLV/PM</b> <b>EZOLV</b><br>Sets the length of time that the output frequency or motor speed must be less than b5-92 [EZ Sleep Level] to enter Sleep Mode. | 5.0 s<br>(0.0 - 1000.0 s) |

### ■ b5-94: EZ Sleep Wake-up Level

| No. (Hex.)             | Name                   | Description  | Default (Range)           |
|------------------------|------------------------|--|---------------------------|
| b5-94<br>(0B94)<br>RUN | EZ Sleep Wake-up Level | <b>V/f</b> <b>CL-V/f</b> <b>OLV</b> <b>CLV</b> <b>AOLV</b> <b>OLV/PM</b> <b>AOLV/PM</b> <b>CLV/PM</b> <b>EZOLV</b><br>Sets the level at which the drive resumes operation when exiting Sleep Mode. | 0.00%<br>(0.00 - 600.00%) |

**Note:**

The values of b5-20 [PID Unit Selection], b5-38 [PID User Unit Display Scaling], and b5-39 [PID User Unit Display Digits] set the units. When b5-20, b5-38, and b5-39 change, this parameter does not automatically update. Set this parameter again after you change b5-20, b5-38, and b5-39 are changed.

- When b5-95 = 0 [EZ Sleep Wake-up Mode = Absolute]:  
When b5-09 = 0 [PID Output Level Selection = Normal Output (Direct Acting)], and the PID Feedback [H3-xx = B] is less than the value of b5-94 for a time longer than the value of b5-96 [EZ Sleep Wake-up Time], the drive will exit sleep and start operation again. When b5-09 = 1 [Reverse Output (Reverse Acting)], and the PID feedback is more than setting value of b5-94 for a time longer than the setting value of b5-96, the drive will exit sleep and start operation again.
- When b5-95 = 1 [Setpoint Delta]:  
When b5-09 = 0, and the PID feedback is less than the value of "PID setpoint value - b5-94" for a time longer than the value of b5-96, the drive will exit sleep and start operation again. When b5-09 = 1, and the PID feedback is

## 2.3 b: Application

more than the value of "PID setpoint value + *b5-94*" for a time longer than the setting value of *b5-96*, the drive will exit sleep and start operation again.

### ■ b5-95: EZ Sleep Wake-up Mode

| No. (Hex.)      | Name                  | Description   | Default (Range) |
|-----------------|-----------------------|---|-----------------|
| b5-95<br>(0B95) | EZ Sleep Wake-up Mode | <b>V/f</b> <b>CL-V/f</b> <b>OLV</b> <b>CLV</b> <b>AOLV</b> <b>OLV/PM</b> <b>AOLV/PM</b> <b>CLV/PM</b> <b>EZOLV</b><br>Sets the wake-up mode to use when exiting Sleep Mode. | 0<br>(0, 1)     |

**0 : Absolute**

**1 : Setpoint Delta**

### ■ b5-96: EZ Sleep Wake-up Time

| No. (Hex.)             | Name                  | Description   | Default (Range)           |
|------------------------|-----------------------|---|---------------------------|
| b5-96<br>(0B96)<br>RUN | EZ Sleep Wake-up Time | <b>V/f</b> <b>CL-V/f</b> <b>OLV</b> <b>CLV</b> <b>AOLV</b> <b>OLV/PM</b> <b>AOLV/PM</b> <b>CLV/PM</b> <b>EZOLV</b><br>Sets the EZ Wake-up time. | 1.0 s<br>(0.0 - 1000.0 s) |

When the PID feedback is less than the value of *b5-94* [*EZ Sleep Wake-up Level*] continuously for the time set in *b5-96*, the drive will exit sleep and start operation again.

## ◆ b6: Dwell Function

The Dwell function momentarily holds the output frequency at start and stop.

This prevents motor speed loss when you start and stop heavy loads. The Dwell function is also enabled when backlash on the machine side causes sudden movement at the start of acceleration and deceleration.

At the start of acceleration, the drive uses the output frequency and acceleration time set for the Dwell function to automatically operate at low speed to minimize the effects of backlash. Then, the drive can accelerate again. The Dwell function operates the same for deceleration.

For conveyor applications, the Dwell function also lets the drive interlock the output frequency and a delay time for the holding brake on the load side.

The Dwell function momentarily stops during acceleration to prevent a PM motor from stepping out. Figure 2.40 shows how the Dwell function works.

#### Note:

When you use the Dwell function at stop, set *b1-03* = 0 [*Stopping Method Selection = Ramp to Stop*].

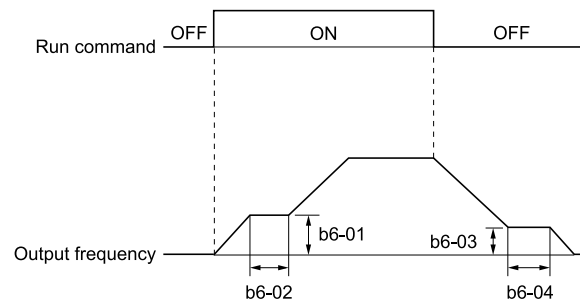


Figure 2.40 Time Chart for the Dwell Function at Start/Stop

### ■ b6-01: Dwell Reference at Start

| No. (Hex.)      | Name                     | Description   | Default (Range)              |
|-----------------|--------------------------|---|------------------------------|
| b6-01<br>(01B6) | Dwell Reference at Start | <b>V/f</b> <b>CL-V/f</b> <b>OLV</b> <b>CLV</b> <b>AOLV</b> <b>OLV/PM</b> <b>AOLV/PM</b> <b>CLV/PM</b> <b>EZOLV</b><br>Sets the output frequency that the drive will hold momentarily when the motor starts. | 0.0<br>(Determined by A1-02) |

When the drive accelerates to the output frequency set in *b6-01*, it holds that frequency for the time set in *b6-02* [*Dwell Time at Start*], and starts to accelerate again.

### ■ b6-02: Dwell Time at Start

| No. (Hex.)   | Name                | Description  | Default (Range)         |
|--------------|---------------------|--|-------------------------|
| b6-02 (01B7) | Dwell Time at Start | <b>V/f</b> <b>CL-V/f</b> <b>OLV</b> <b>CLV</b> <b>AOLV</b> <b>OLV/PM</b> <b>AOLV/PM</b> <b>CLV/PM</b> <b>EZOLV</b><br>Sets the length of time that the drive will hold the output frequency when the motor starts. | 0.0 s<br>(0.0 - 10.0 s) |

### ■ b6-03: Dwell Reference at Stop

| No. (Hex.)   | Name                    | Description  | Default (Range)              |
|--------------|-------------------------|--|------------------------------|
| b6-03 (01B8) | Dwell Reference at Stop | <b>V/f</b> <b>CL-V/f</b> <b>OLV</b> <b>CLV</b> <b>AOLV</b> <b>OLV/PM</b> <b>AOLV/PM</b> <b>CLV/PM</b> <b>EZOLV</b><br>Sets the output frequency that the drive will hold momentarily when ramping to stop the motor. | 0.0<br>(Determined by A1-02) |

When the drive decelerates to the output frequency set in *b6-03*, it holds that frequency for the time set in *b6-04* [*Dwell Time at Stop*] and starts to decelerate again.

### ■ b6-04: Dwell Time at Stop

| No. (Hex.)   | Name               | Description  | Default (Range)         |
|--------------|--------------------|--|-------------------------|
| b6-04 (01B9) | Dwell Time at Stop | <b>V/f</b> <b>CL-V/f</b> <b>OLV</b> <b>CLV</b> <b>AOLV</b> <b>OLV/PM</b> <b>AOLV/PM</b> <b>CLV/PM</b> <b>EZOLV</b><br>Sets the length of time for the drive to hold the output frequency when ramping to stop the motor. | 0.0 s<br>(0.0 - 10.0 s) |

## ◆ b7: Droop Control

Droop control automatically balances the load level between two motors that operate the same load.

Droop control decreases motor speed as the load changes. You must enable the Droop control function for each motor it is operating.

To decrease motor speed, the Droop control function decreases the speed reference when an increase in the load increases the torque reference. To increase motor speed, the Droop control function increases the speed reference when a decrease in the load decreases the torque reference. The Droop control function adjusts motor speed as the torque reference changes to balance the load between the motors.

#### Note:

When you use Droop control, set *n5-01* = 0 [*Feed Forward Control Selection* = Disabled].

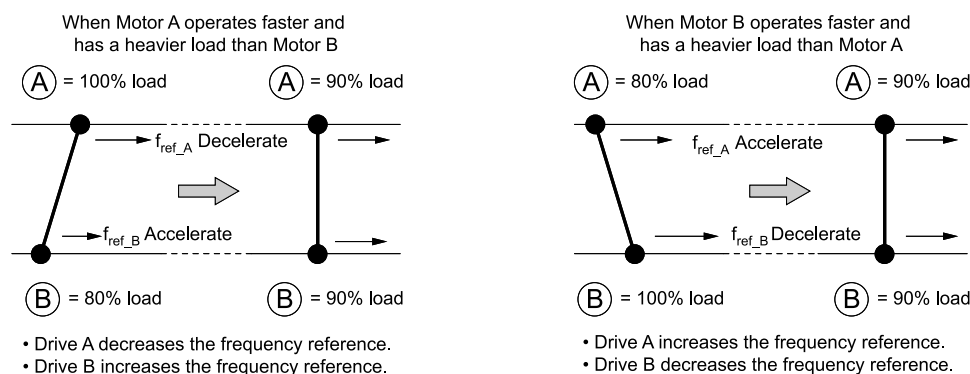


Figure 2.41 Droop Control Application

## 2.3 b: Application

### ■ b7-01: Droop Control Gain

| No. (Hex.)             | Name               | Description   | Default (Range)        |
|------------------------|--------------------|---|------------------------|
| b7-01<br>(01CA)<br>RUN | Droop Control Gain | <div style="display: flex; justify-content: space-between; font-size: small;"> <span>V/f</span> <span>CL-V/f</span> <span>OLV</span> <span style="background-color: black; color: white;">CLV</span> <span>AOLV</span> <span>OLV/PM</span> <span>AOLV/PM</span> <span style="background-color: black; color: white;">CLV/PM</span> <span>EZOLV</span> </div> Sets the amount of deceleration when the torque reference is at 100% as a percentage of <i>E1-04</i> [Maximum Output Frequency]. | 0.0%<br>(0.0 - 100.0%) |

To disable Droop control, set this parameter to 0.0%.

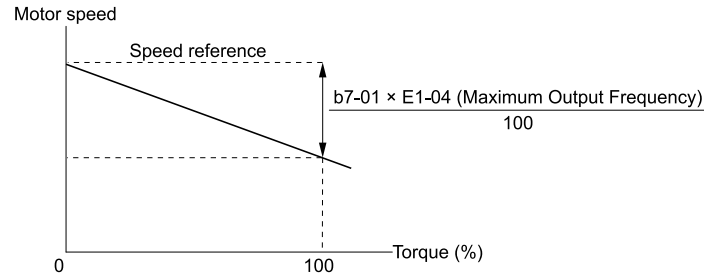


Figure 2.42 Droop Control Gain

### ■ b7-02: Droop Control Delay Time

| No. (Hex.)             | Name                     | Description  | Default (Range)           |
|------------------------|--------------------------|--|---------------------------|
| b7-02<br>(01CB)<br>RUN | Droop Control Delay Time | <div style="display: flex; justify-content: space-between; font-size: small;"> <span>V/f</span> <span>CL-V/f</span> <span>OLV</span> <span style="background-color: black; color: white;">CLV</span> <span>AOLV</span> <span>OLV/PM</span> <span>AOLV/PM</span> <span style="background-color: black; color: white;">CLV/PM</span> <span>EZOLV</span> </div> Sets the responsiveness of Droop control. Decrease this setting when drive response is slow. Increase this setting when hunting or oscillation occur. | 0.05 s<br>(0.03 - 2.00 s) |

### ■ b7-03: Droop Control Limit Selection

| No. (Hex.)      | Name                          | Description   | Default (Range) |
|-----------------|-------------------------------|---|-----------------|
| b7-03<br>(017E) | Droop Control Limit Selection | <div style="display: flex; justify-content: space-between; font-size: small;"> <span>V/f</span> <span>CL-V/f</span> <span>OLV</span> <span style="background-color: black; color: white;">CLV</span> <span>AOLV</span> <span>OLV/PM</span> <span>AOLV/PM</span> <span style="background-color: black; color: white;">CLV/PM</span> <span>EZOLV</span> </div> Sets the Droop control limit function. | 1<br>(0, 1)     |

0 : Disabled

1 : Enabled

## ◆ b8: Energy Saving

Energy-saving control improves overall system operating efficiency by operating the motor at its most efficient level. Set *b8-01* and the following parameters according to the control mode and the motor.

- Set parameters *b8-04*, *b8-05*, and *b8-06* when using V/f Control or Closed Loop V/f Control.
- Set parameters *b8-02*, *b8-03* when using vector control with an induction motor.
- Set parameters *b8-16*, *b8-17* when using a PM motor.

**Note:**

- Energy-saving control is not appropriate for applications with sudden changes in the load, or applications driving heavy loads such as a traverse car application.
- Energy-saving control maximizes operation based on precise motor data set to the drive. Be sure to perform Auto-Tuning and enter the correct information about the motor before using the Energy-saving control.

### ■ b8-01: Energy Saving Control Selection

| No. (Hex.)      | Name                            | Description  | Default (Range) |
|-----------------|---------------------------------|--|-----------------|
| b8-01<br>(01CC) | Energy Saving Control Selection | <div style="display: flex; justify-content: space-between; font-size: small;"> <span style="background-color: black; color: white;">V/f</span> <span>CL-V/f</span> <span>OLV</span> <span style="background-color: black; color: white;">CLV</span> <span>AOLV</span> <span style="background-color: black; color: white;">OLV/PM</span> <span style="background-color: black; color: white;">AOLV/PM</span> <span style="background-color: black; color: white;">CLV/PM</span> <span>EZOLV</span> </div> Sets the Energy-saving control function. | 0<br>(0 - 2)    |

0 : Energy Saving Control Disabled

**1 : Energy Saving Control Enabled****2 : Automatic Optimization****Note:**

The Setting 2 is available only when  $A1-02 = 6, 7$  [Control Method Selection = AOLV/PM, CLV/PM] and in Expert Mode.

**■ b8-02: Energy Saving Gain**

| No. (Hex.)                       | Name               | Description  | Default (Range)                     |
|----------------------------------|--------------------|--|-------------------------------------|
| b8-02<br>(01CD)<br>RUN<br>Expert | Energy Saving Gain | V/f CL-V/f <b>OLV</b> <b>CLV</b> <b>AOLV</b> OLV/PM AOLV/PM CLV/PM EZOLV<br>Sets the gain for Energy-saving control. | Determined by A1-02<br>(0.0 - 10.0) |

Increase the setting value to increase energy saving. If the setting value is too large, the motor will stall.

**■ b8-03: Energy Saving Filter Time**

| No. (Hex.)                       | Name                      | Description  | Default (Range)  |
|----------------------------------|---------------------------|--|--|
| b8-03<br>(01CE)<br>RUN<br>Expert | Energy Saving Filter Time | V/f CL-V/f <b>OLV</b> <b>CLV</b> <b>AOLV</b> OLV/PM AOLV/PM CLV/PM EZOLV<br>Sets the responsiveness for Energy-saving control. | Determined by A1-02, C6-01 and o2-04<br>(0.00 - 10.00 s) |

Decrease the setting value to increase responsiveness. If the setting value is too low, operation will not be stable.

**■ b8-04: Energy Saving Coefficient Value**

| No. (Hex.)                | Name                            | Description  | Default (Range)  |
|---------------------------|---------------------------------|--|--|
| b8-04<br>(01CF)<br>Expert | Energy Saving Coefficient Value | V/f <b>CL-V/f</b> <b>OLV</b> <b>CLV</b> <b>AOLV</b> OLV/PM AOLV/PM CLV/PM EZOLV<br>Sets the Energy-saving control coefficient to maintain maximum motor efficiency. The default setting is for Yaskawa motors. | Determined by C6-01, E2-11, and o2-04<br>(0.00 - 655.00) |

When you use a motor from a different manufacturer, increase the setting value in 5% increments to find the minimum value for  $U1-08$  [Output Power] at light loads.

When you decrease the setting value, it decreases the output voltage and decreases power consumption. If the setting value is too low, the motor will stall.

**Note:**

When you do Rotational Auto-Tuning, the drive will automatically set the energy-saving coefficient.

**■ b8-05: Power Detection Filter Time**

| No. (Hex.)                | Name                        | Description  | Default (Range)        |
|---------------------------|-----------------------------|--|------------------------|
| b8-05<br>(01D0)<br>Expert | Power Detection Filter Time | V/f <b>CL-V/f</b> <b>OLV</b> <b>CLV</b> <b>AOLV</b> OLV/PM AOLV/PM CLV/PM EZOLV<br>Sets the time constant to measure output power. | 20 ms<br>(0 - 2000 ms) |

Decrease the setting value to increase responsiveness to load changes. If you set the value too low during operation at light loads, motor speed is not stable.

**■ b8-06: PM E-Save Search Voltage Limiter**

| No. (Hex.)                | Name                             | Description  | Default (Range)  |
|---------------------------|----------------------------------|--|------------------|
| b8-06<br>(01D1)<br>Expert | PM E-Save Search Voltage Limiter | V/f <b>CL-V/f</b> <b>OLV</b> <b>CLV</b> <b>AOLV</b> OLV/PM AOLV/PM CLV/PM EZOLV<br>Sets the voltage limit for Search Operation as a percentage of the motor rated voltage. | 0%<br>(0 - 100%) |

## 2.3 b: Application

The Search Operation changes the output voltage in small increments to find a setpoint at which the drive can use minimum power to operate.

Set this parameter to 0 to disable Search Operation. This will not disable Energy-saving control.

If the setting value is too low, the motor will stall when loads suddenly increase.

### ■ b8-16: PM E-Save Coefficient Ki

| No. (Hex.)                | Name                     | Description  | Default (Range)       |
|---------------------------|--------------------------|--|-----------------------|
| b8-16<br>(01F8)<br>Expert | PM E-Save Coefficient Ki | V/f CL-V/f OLV CLV AOLV OLV/PM AOLV/PM CLV/PM EZOLV<br>Sets torque linearity. This parameter uses the Ki value from the motor nameplate. Usually it is not necessary to change this setting. | 1.00<br>(0.00 - 3.00) |

When  $b8-16 = 1.00$  (default), the drive will automatically calculate and control the energy-saving coefficient. If the motor nameplate has a description for “Ki”, set this parameter to the Ki value.

Do this procedure to prevent oscillation when you set  $b8-01 = 1$  [Energy Saving Control Selection = Enabled].

1. Check  $U5-21$  [Energy Save Coeff Ki] and make sure that it aligns with the Ki value on the motor nameplate.
2. If the numbers are different, set  $b8-16$  to the Ki value on the motor nameplate.

### ■ b8-17: PM E-Save Coefficient Kt

| No. (Hex.)                | Name                     | Description  | Default (Range)       |
|---------------------------|--------------------------|--|-----------------------|
| b8-17<br>(01F9)<br>Expert | PM E-Save Coefficient Kt | V/f CL-V/f OLV CLV AOLV OLV/PM AOLV/PM CLV/PM EZOLV<br>Sets torque linearity. This parameter uses the Kt value from the motor nameplate. Usually it is not necessary to change this setting. | 1.00<br>(0.00 - 3.00) |

When  $E5-01 = 1xxx, 2xxx$  [PM Motor Code Selection = Yaskawa SSR1 or SST4 series IPM motor], the drive automatically calculates the energy-saving coefficient Kt and uses that value to control operation.

Do this procedure to prevent oscillation when you set  $b8-01 = 1$  [Energy Saving Control Selection = Enabled].

1. Check  $U5-22$  [Energy Save Coeff Kt] and make sure that it aligns with the Kt value on the motor nameplate.
2. If the numbers are different, set  $b8-17$  to the Kt value on the motor nameplate.

### ■ b8-18: E-Save d-axis Current FilterTime

| No. (Hex.)                | Name                             | Description  | Default (Range)              |
|---------------------------|----------------------------------|--|------------------------------|
| b8-18<br>(01FA)<br>Expert | E-Save d-axis Current FilterTime | V/f CL-V/f OLV CLV AOLV OLV/PM AOLV/PM CLV/PM EZOLV<br>Sets the d-axis current reference filter time constant. | 0.100 s<br>(0.000 - 5.000 s) |

### ■ b8-19: E-Save Search Frequency

| No. (Hex.)                | Name                    | Description   | Default (Range)                      |
|---------------------------|-------------------------|---|--------------------------------------|
| b8-19<br>(0B40)<br>Expert | E-Save Search Frequency | V/f CL-V/f OLV CLV AOLV OLV/PM AOLV/PM CLV/PM EZOLV<br>Sets the frequency of Energy-saving control search operations. Usually it is not necessary to change this setting. | Determined by A1-02<br>(10 - 300 Hz) |

#### Note:

- If low inertia causes vibration in the machine, increase the setting value in 10 Hz increments and check the response. If  $A1-02 = 8$  [Control Method Selection = EZOLV], increase the setting value in 1 Hz increments.
- To make the motor more efficient, decrease the setting value in 1 Hz increments until the point immediately before machine vibration starts to occur.



### ■ b8-20: E-Save Search Width

| No. (Hex.)                | Name                | Description   | Default (Range)                    |
|---------------------------|---------------------|---|------------------------------------|
| b8-20<br>(0B41)<br>Expert | E-Save Search Width | V/f CL-V/f OLV CLV AOLV OLV/PM AOLV/PM CLV/PM EZOLV<br>Sets the amplitude of Energy-saving control search operations. | 1.0 degrees<br>(0.1 - 5.0 degrees) |

An increase in the value can make the operational efficiency better. However, if the load inertia is small, it may be necessary to adjust the value to prevent machine vibration.

**Note:**

- If low inertia causes vibration in the machine, decrease the setting value in 1.0-degree increments and check the response.
- To make the motor more efficient, increase the setting value in 1.0-degree increments until the point immediately before machine vibration starts to occur.

### ■ b8-21: PM E-Save Search Gain

| No. (Hex.)                | Name                  | Description  | Default (Range)          |
|---------------------------|-----------------------|--|--------------------------|
| b8-21<br>(0B42)<br>Expert | PM E-Save Search Gain | V/f CL-V/f OLV CLV AOLV OLV/PM AOLV/PM CLV/PM EZOLV<br>Sets the gain of Energy-saving control search operations. | 0.3Hz<br>(0.1 - 20.0 Hz) |

When you decrease the value of *C5-01 [ASR Proportional Gain 1]*, also decrease the value of *b8-21* to keep the correct ratio.

### ■ b8-22: PM E-Save Search LPF Cutoff Freq

| No. (Hex.)                | Name                             | Description   | Default (Range)            |
|---------------------------|----------------------------------|---|----------------------------|
| b8-22<br>(0B43)<br>Expert | PM E-Save Search LPF Cutoff Freq | V/f CL-V/f OLV CLV AOLV OLV/PM AOLV/PM CLV/PM EZOLV<br>Sets the frequency of the filter used to extract the high-efficiency phase from search operations. Usually it is not necessary to change this setting. | 10.0 Hz<br>(1.0 - 30.0 Hz) |

### ■ b8-23: PM E-Save Search Limit

| No. (Hex.)                | Name                   | Description   | Default (Range)                      |
|---------------------------|------------------------|---|--------------------------------------|
| b8-23<br>(0B44)<br>Expert | PM E-Save Search Limit | V/f CL-V/f OLV CLV AOLV OLV/PM AOLV/PM CLV/PM EZOLV<br>Sets the search operations output limit. Usually it is not necessary to change this setting. | 15.0 degrees<br>(0.0 - 30.0 degrees) |

When the motor characteristics are correct, increase this value to make the motor more efficient.

### ■ b8-24: PM E-Save High Freq ACR Gain

| No. (Hex.)                | Name                         | Description  | Default (Range)                 |
|---------------------------|------------------------------|--|---------------------------------|
| b8-24<br>(0B45)<br>Expert | PM E-Save High Freq ACR Gain | V/f CL-V/f OLV CLV AOLV OLV/PM AOLV/PM CLV/PM EZOLV<br>Sets the gain for high-frequency current control. | 200.0 Hz<br>(100.0 - 1000.0 Hz) |

**Note:**

If the drive detects *oC [Overcurrent]*, decrease the value.

### ■ b8-25: PM E-Save Search Start Level

| No. (Hex.)                | Name                         | Description  | Default (Range)         |
|---------------------------|------------------------------|--|-------------------------|
| b8-25<br>(0B46)<br>Expert | PM E-Save Search Start Level | V/f CL-V/f OLV CLV AOLV OLV/PM AOLV/PM CLV/PM EZOLV<br>Sets the start level for search operations. | 10.0%<br>(0.0 - 100.0%) |

## 2.3 b: Application

**Note:**

If there is vibration in the machine, increase the value.

### ■ b8-26: PM E-Save Power Setpoint

| No. (Hex.)                | Name                     | Description  | Default (Range)          |
|---------------------------|--------------------------|--|--------------------------|
| b8-26<br>(0B47)<br>Expert | PM E-Save Power Setpoint | V/f CL-V/f OLV CLV AOLV OLV/PM AOLV/PM CLV/PM EZOLV<br>Sets a value to increase torque accuracy. | 0.0%<br>(-10.0 - +10.0%) |

### ■ b8-28: Over Excitation Action Selection

| No. (Hex.)                | Name                             | Description  | Default (Range) |
|---------------------------|----------------------------------|--|-----------------|
| b8-28<br>(0B8B)<br>Expert | Over Excitation Action Selection | V/f CL-V/f OLV CLV AOLV OLV/PM AOLV/PM CLV/PM EZOLV<br>Sets the function for excitation operation. | 0<br>(0, 1)     |

When operation is not stable at low speeds, set this parameter to 1 to enable the function.

**0 : Disabled**

**1 : Enabled**

### ■ b8-29: Energy Saving Priority Selection

| No. (Hex.)      | Name                             | Description   | Default (Range) |
|-----------------|----------------------------------|---|-----------------|
| b8-29<br>(0B8C) | Energy Saving Priority Selection | V/f CL-V/f OLV CLV AOLV OLV/PM AOLV/PM CLV/PM EZOLV<br>Sets whether to prioritize tracking related to load changes or energy-saving control. Enable this to prioritize energy-saving control. Disable it to favor tracking related to rapid load changes, thereby preventing motor stall. | 0<br>(0, 1)     |

Enable this parameter when there are small changes in the load. It is possible that the motor cannot respond correctly to changes in the load.

**0 : Priority: Drive Response**

**1 : Priority: Energy Savings**

### ■ b8-50: Standby Mode Selection

| No. (Hex.)      | Name                   | Description  | Default (Range) |
|-----------------|------------------------|--|-----------------|
| b8-50<br>(0B0D) | Standby Mode Selection | V/f CL-V/f OLV CLV AOLV OLV/PM AOLV/PM CLV/PM EZOLV<br>Sets the Standby Mode function. | 0<br>(0, 1)     |

**0 : No**

**1 : Yes**

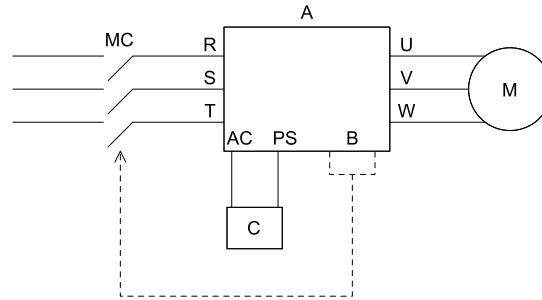
Standby Mode decreases how much power the drive consumes when it is in standby.

Standby Mode waits for the drive to stop, then uses the relay output of an MFDO terminal to shut off the input side electromagnetic contactor (MC) and then shut off the main circuit power supply.

**Note:**

These conditions are also necessary for Standby Mode:

- Connect an external 24 V power supply.
- Connect an electromagnetic contactor to the drive input side and connect the MFDO terminal set for  $H2-xx = 65$  [Standby Output]. When the MFDO terminal is OFF, the electromagnetic contactor must be OFF.
- Frequently starting and stopping the drive and regularly opening and closing the electromagnetic contactor will decrease the service life of the drive.



A - Drive  
 B - MFDO Terminal  
 C - External 24 V power supply

■ **b8-51: Standby Mode Wait Time**

| No. (Hex.)   | Name                   | Description   | Default (Range)       |
|--------------|------------------------|---|-----------------------|
| b8-51 (0B01) | Standby Mode Wait Time | <b>V/f</b> <b>CL-V/f</b> <b>OLV</b> <b>CLV</b> <b>AOLV</b> <b>OLV/PM</b> <b>AOLV/PM</b> <b>CLV/PM</b> <b>EZOLV</b><br>Sets the delay time before turning off the electromagnetic contactor after the drive stops. | 600 s<br>(0 - 6000 s) |

◆ **b9: Zero Servo**

Zero Servo is a position control function that stops and holds the motor shaft. The drive safeties the stopped motor and an external force will not move the motor.

When you enable the Zero Servo function, the drive will save the home position. The drive can correct the motor position and put the motor into the home position when the load rotates the motor.

To enable Zero Servo, set  $H1-xx = 72$  [MFDI Function Selection = Zero Servo]. The drive starts Zero Servo when the MFDI terminal set for Zero Servo [ $H1-xx = 72$ ] activates and the motor speed decreases to less than the value set in  $b2-01$  [DC Injection/Zero SpeedThreshold]. The drive stops and holds the motor in the Zero Servo start position. When Zero Servo is enabled, the drive will hold the motor in position when the frequency reference increases to more than the value set in  $b2-01$ . When Zero Servo is enabled, the drive will hold the motor in position when the frequency reference increases to more than the value set in  $b2-01$ .

**Note:**

Zero Servo is available when  $A1-02 = 3, 7$  [Control Method Selection = Closed Loop Vector; PM Closed Loop Vector].

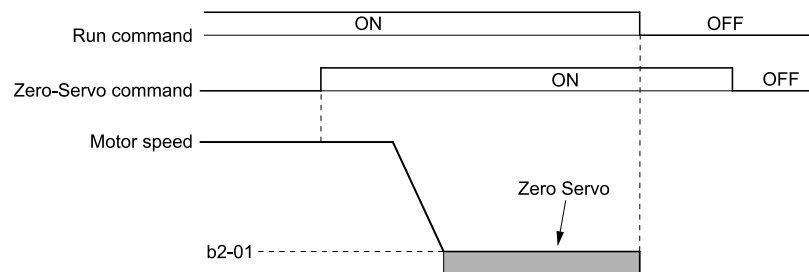


Figure 2.43 Zero Servo Time Chart

Monitor  $U6-22$  [ZeroServoPulse Move] shows the difference between the position of the motor shaft and the Zero Servo start position when Zero Servo is enabled. To find the difference, divide the number of pulses shown in  $U6-22$  by 4.

When the position of the motor shaft is in the range of “Zero Servo start position  $\pm b9-02$  [Zero Servo Completion Window]”, the drive will activate an MFDO set for Zero Servo Complete [ $H2-xx = 33$ ].

**NOTICE:** Do not let the Zero Servo function hold 100% load for long periods of time. When the application must use Zero Servo to hold 100% load for long periods, operate in less than 50% of the drive rated output current or use a larger capacity drive. If Zero Servo holds the load for too long in 50% or more of the drive rated output current, it will cause damage to the drive.

## 2.3 b: Application

**Note:**

- When you use the Zero Servo function, keep the Run command ON. If the Run command is OFF, the drive will not hold the motor shaft in position.
- When you turn OFF the Zero-Servo command, the terminal set for Zero Servo Complete will deactivate.
- If  $A1-02 = 7$  [PM Closed Loop Vector] and an external force rotates the motor during Zero Servo, the drive will detect  $dv4$  [Inversion Prevention Detection]. To prevent  $dv4$  detection, increase  $b9-01$  [Zero Servo Gain] or increase the number of pulses set in  $F1-19$  [Deviation 4 Detection Selection].

### ■ b9-01: Zero Servo Gain

| No. (Hex.)      | Name            | Description   | Default (Range) |
|-----------------|-----------------|---|-----------------|
| b9-01<br>(01DA) | Zero Servo Gain | <div style="display: flex; justify-content: space-between; font-size: small;"> <span>V/f</span> <span>CL-V/f</span> <span>OLV</span> <span style="background-color: #333; color: white; padding: 2px;">CLV</span> <span>AOLV</span> <span>OLV/PM</span> <span>AOLV/PM</span> <span style="background-color: #333; color: white; padding: 2px;">CLV/PM</span> <span>EZOLV</span> </div> Sets the responsiveness for the Zero Servo function. | 5<br>(0 - 100)  |

If the drive is not responsive, or if there is too much deviation from the Zero Servo start point when you increase the load, increase this setting. If oscillation or hunting occurs, decrease this setting.

**Note:**

- Set  $C5-xx$  [Automatic Speed Regulator (ASR)] parameters correctly before you adjust the Zero Servo gain.
- When you operate with the Zero Servo command enabled, oscillation and hunting must not occur.

### ■ b9-02: Zero Servo Completion Window

| No. (Hex.)      | Name                         | Description   | Default (Range)   |
|-----------------|------------------------------|---|-------------------|
| b9-02<br>(01DB) | Zero Servo Completion Window | <div style="display: flex; justify-content: space-between; font-size: small;"> <span>V/f</span> <span>CL-V/f</span> <span>OLV</span> <span style="background-color: #333; color: white; padding: 2px;">CLV</span> <span>AOLV</span> <span>OLV/PM</span> <span>AOLV/PM</span> <span style="background-color: #333; color: white; padding: 2px;">CLV/PM</span> <span>EZOLV</span> </div> Sets the range to trigger an output terminal set for “Zero Servo Complete” during Zero Servo operation. Be sure to set the deviation from the Zero Servo start position. | 10<br>(0 - 16383) |

When the position of the motor shaft is in the range of “Zero Servo start position  $\pm b9-02$ ”, the drive will activate a MFDO set for *Zero Servo Complete* [ $H2-xx = 33$ ].

## 2.4 C: Tuning

*C* parameters adjust drive operation, including:

- Acceleration Time
- Deceleration Time
- Slip Compensation
- Torque Compensation
- Carrier Frequency

### ◆ C1: Acceleration and deceleration times

You can set four different acceleration and deceleration time pairs in the drive. When you activate and deactivate H1-xx = 7, 16, 1A [MFDI Function Select = Accel/Decel Time Selection 1, Motor 2 Selection, Accel/Decel Time Selection 2], you can switch acceleration and deceleration times during run.

Acceleration time parameters always set the time to accelerate from 0 Hz to *E1-04* [Maximum Output Frequency]. Deceleration time parameters always set the time to decelerate from *E1-04* to 0 Hz.

*C1-01* [Acceleration Time 1] and *C1-02* [Deceleration Time 1] are the default active accel/decel settings.

| Parameter                   | Range           |
|-----------------------------|-----------------|
| C1-01 [Acceleration Time 1] | 0.0 to 6000.0 s |
| C1-02 [Deceleration Time 1] |                 |
| C1-03 [Acceleration Time 2] |                 |
| C1-04 [Deceleration Time 2] |                 |
| C1-05 [Acceleration Time 3] |                 |
| C1-06 [Deceleration Time 3] |                 |
| C1-07 [Acceleration Time 4] |                 |
| C1-08 [Deceleration Time 4] |                 |

**Note:**

The setting range for acceleration and deceleration times is 0.00 to 600.00 s when *C1-10* = 0 [Accel/Decel Time Setting Units = 0.01 s (0.00 to 600.00 s)].

### ■ Use MFDIs to Switch Acceleration Times

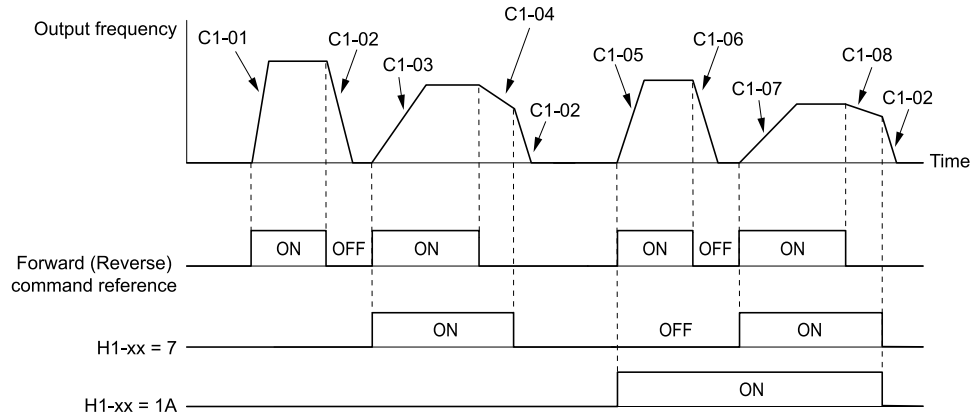
Table 2.29 shows the different acceleration and deceleration times.

**Table 2.29 Accel/Decel Times and Active Parameters**

| H1-xx = 7<br>[Accel/Decel Time Selection 1] | H1-xx = 1A<br>[Accel/Decel Time Selection 2] | Active Parameter            |                             |
|---|--|-----------------------------|-----------------------------|
|   |  | Acceleration Time           | Deceleration Time           |
| OFF   | OFF  | C1-01 [Acceleration Time 1] | C1-02 [Deceleration Time 1] |
| ON  | OFF  | C1-03 [Acceleration Time 2] | C1-04 [Deceleration Time 2] |
| OFF   | ON   | C1-05 [Acceleration Time 3] | C1-06 [Deceleration Time 3] |
| ON  | ON   | C1-07 [Acceleration Time 4] | C1-08 [Deceleration Time 4] |

Figure 2.44 shows an operation example to change acceleration and deceleration times. It is necessary to set *b1-03* = 0 [Stopping Method Selection = Ramp to Stop] for this example.

## 2.4 C: Tuning



**Figure 2.44 Timing Diagram of Acceleration and Deceleration Times**

### ■ Use Motor Selection to Switch Acceleration and Deceleration Times

When you set  $H1-xx = 16$  [MFDI Function Selection = Motor 2 Selection], you can activate and deactivate the input terminal to switch between motor 1 and motor 2.

**Note:**

You cannot use the Motor 2 Selection function with PM motors.

Table 2.30 shows the possible acceleration and deceleration time combinations when you use the Motor 2 Selection function.

**Table 2.30 Motor Selection and Acceleration and Deceleration Times**

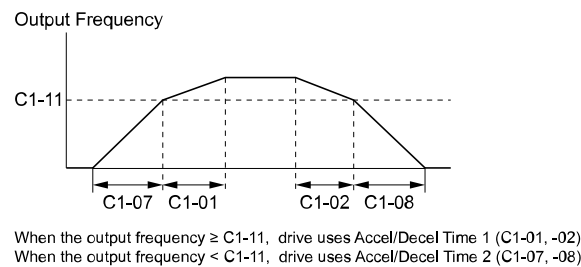
| H1-xx = 7<br>[Accel/Decel Time Selection<br>1] | H1-xx = 16 [Motor 2 Selection] |                   |                       |                   |
|--|--------------------------------|-------------------|-----------------------|-------------------|
|  | Motor 2 Selection: OFF         |                   | Motor 2 Selection: ON |                   |
|  | Acceleration Time              | Deceleration Time | Acceleration Time     | Deceleration Time |
| OFF  | C1-01                          | C1-02             | C1-05                 | C1-06             |
| ON   | C1-03                          | C1-04             | C1-07                 | C1-08             |

### ■ Use Output Frequency Level to Switch Acceleration and Deceleration Times

The drive can use output frequency to automatically switch between different acceleration and deceleration times. When the output frequency =  $C1-11$  [Accel/Decel Time Switchover Freq], the drive automatically switches the acceleration and deceleration times. Set  $C1-11 = 0.0$  Hz to disable this function.

**Note:**

- Acceleration and deceleration times set to MFDIs are more important than the automatic switch using the frequency level set in  $C1-11$ . For example, if you set the switchover frequency to  $C1-11$ , the drive will not automatically switch acceleration and deceleration times when the MFDI terminal set for *Accel/Decel Time Selection 1* [ $H1-xx = 7$ ] is activated.
- If Motor 2 Selection [ $H1-xx = 16$ ] is activated, the drive will set the acceleration/deceleration time to  $C1-05$  and  $C1-06$  for motor 2 when the output frequency is more than the frequency level set in  $C1-11$ .



**Figure 2.45 Accel/Decel Time Switching Frequency**

### ■ C1-01: Acceleration Time 1

| No. (Hex.)             | Name                | Description  | Default (Range)            |
|------------------------|---------------------|--|----------------------------|
| C1-01<br>(0200)<br>RUN | Acceleration Time 1 | <b>V/f</b> <b>CL-V/f</b> <b>OLV</b> <b>CLV</b> <b>AOLV</b> <b>OLV/PM</b> <b>AOLV/PM</b> <b>CLV/PM</b> <b>EZOLV</b><br>Sets the length of time to accelerate from zero to maximum output frequency. | 10.0 s<br>(0.0 - 6000.0 s) |

**Note:**

When  $C1-10 = 0$  [Accel/Decel Time Setting Units = 0.01 s (0.00 to 600.00 s)], the setting range is 0.00 to 600.00 s.

### ■ C1-02: Deceleration Time 1

| No. (Hex.)             | Name                | Description  | Default (Range)            |
|------------------------|---------------------|--|----------------------------|
| C1-02<br>(0201)<br>RUN | Deceleration Time 1 | <b>V/f</b> <b>CL-V/f</b> <b>OLV</b> <b>CLV</b> <b>AOLV</b> <b>OLV/PM</b> <b>AOLV/PM</b> <b>CLV/PM</b> <b>EZOLV</b><br>Sets the length of time to decelerate from maximum output frequency to zero. | 10.0 s<br>(0.0 - 6000.0 s) |

**Note:**

When  $C1-10 = 0$  [Accel/Decel Time Setting Units = 0.01 s (0.00 to 600.00 s)], the setting range is 0.00 to 600.00 s.

### ■ C1-03: Acceleration Time 2

| No. (Hex.)             | Name                | Description  | Default (Range)            |
|------------------------|---------------------|--|----------------------------|
| C1-03<br>(0202)<br>RUN | Acceleration Time 2 | <b>V/f</b> <b>CL-V/f</b> <b>OLV</b> <b>CLV</b> <b>AOLV</b> <b>OLV/PM</b> <b>AOLV/PM</b> <b>CLV/PM</b> <b>EZOLV</b><br>Sets the length of time to accelerate from zero to maximum output frequency. | 10.0 s<br>(0.0 - 6000.0 s) |

**Note:**

When  $C1-10 = 0$  [Accel/Decel Time Setting Units = 0.01 s (0.00 to 600.00 s)], the setting range is 0.00 to 600.00 s.

### ■ C1-04: Deceleration Time 2

| No. (Hex.)             | Name                | Description  | Default (Range)            |
|------------------------|---------------------|--|----------------------------|
| C1-04<br>(0203)<br>RUN | Deceleration Time 2 | <b>V/f</b> <b>CL-V/f</b> <b>OLV</b> <b>CLV</b> <b>AOLV</b> <b>OLV/PM</b> <b>AOLV/PM</b> <b>CLV/PM</b> <b>EZOLV</b><br>Sets the length of time to decelerate from maximum output frequency to zero. | 10.0 s<br>(0.0 - 6000.0 s) |

**Note:**

When  $C1-10 = 0$  [Accel/Decel Time Setting Units = 0.01 s (0.00 to 600.00 s)], the setting range is 0.00 to 600.00 s.

### ■ C1-05: Acceleration Time 3

| No. (Hex.)             | Name                | Description  | Default (Range)            |
|------------------------|---------------------|--|----------------------------|
| C1-05<br>(0204)<br>RUN | Acceleration Time 3 | <b>V/f</b> <b>CL-V/f</b> <b>OLV</b> <b>CLV</b> <b>AOLV</b> <b>OLV/PM</b> <b>AOLV/PM</b> <b>CLV/PM</b> <b>EZOLV</b><br>Sets the length of time to accelerate from zero to maximum output frequency. | 10.0 s<br>(0.0 - 6000.0 s) |

**Note:**

When  $C1-10 = 0$  [Accel/Decel Time Setting Units = 0.01 s (0.00 to 600.00 s)], the setting range is 0.00 to 600.00 s.

### ■ C1-06: Deceleration Time 3

| No. (Hex.)             | Name                | Description  | Default (Range)            |
|------------------------|---------------------|--|----------------------------|
| C1-06<br>(0205)<br>RUN | Deceleration Time 3 | <b>V/f</b> <b>CL-V/f</b> <b>OLV</b> <b>CLV</b> <b>AOLV</b> <b>OLV/PM</b> <b>AOLV/PM</b> <b>CLV/PM</b> <b>EZOLV</b><br>Sets the length of time to decelerate from maximum output frequency to zero. | 10.0 s<br>(0.0 - 6000.0 s) |

**Note:**

When  $C1-10 = 0$  [Accel/Decel Time Setting Units = 0.01 s (0.00 to 600.00 s)], the setting range is 0.00 to 600.00 s.

## 2.4 C: Tuning

### ■ C1-07: Acceleration Time 4

| No. (Hex.)             | Name                | Description  | Default (Range)            |
|------------------------|---------------------|--|----------------------------|
| C1-07<br>(0206)<br>RUN | Acceleration Time 4 | <b>V/f</b> <b>CL-V/f</b> <b>OLV</b> <b>CLV</b> <b>AOLV</b> <b>OLV/PM</b> <b>AOLV/PM</b> <b>CLV/PM</b> <b>EZOLV</b><br>Sets the length of time to accelerate from zero to maximum output frequency. | 10.0 s<br>(0.0 - 6000.0 s) |

**Note:**

When  $C1-10 = 0$  [Accel/Decel Time Setting Units = 0.01 s (0.00 to 600.00 s)], the setting range is 0.00 to 600.00 s.

### ■ C1-08: Deceleration Time 4

| No. (Hex.)             | Name                | Description  | Default (Range)            |
|------------------------|---------------------|--|----------------------------|
| C1-08<br>(0207)<br>RUN | Deceleration Time 4 | <b>V/f</b> <b>CL-V/f</b> <b>OLV</b> <b>CLV</b> <b>AOLV</b> <b>OLV/PM</b> <b>AOLV/PM</b> <b>CLV/PM</b> <b>EZOLV</b><br>Sets the length of time to decelerate from maximum output frequency to zero. | 10.0 s<br>(0.0 - 6000.0 s) |

**Note:**

When  $C1-10 = 0$  [Accel/Decel Time Setting Units = 0.01 s (0.00 to 600.00 s)], the setting range is 0.00 to 600.00 s.

### ■ C1-09: Fast Stop Time

| No. (Hex.)             | Name           | Description   | Default (Range)            |
|------------------------|----------------|---|----------------------------|
| C1-09<br>(0208)<br>RUN | Fast Stop Time | <b>V/f</b> <b>CL-V/f</b> <b>OLV</b> <b>CLV</b> <b>AOLV</b> <b>OLV/PM</b> <b>AOLV/PM</b> <b>CLV/PM</b> <b>EZOLV</b><br>Sets the length of time that the drive will decelerate to zero for a Fast Stop. | 10.0 s<br>(0.0 - 6000.0 s) |

**Note:**

- When  $C1-10 = 0$  [Accel/Decel Time Setting Units = 0.01 s (0.00 to 600.00 s)], the setting range is 0.00 to 600.00 s.
- When  $L2-29 = 0$  [Kinetic Energy Backup Method = Single Drive KEB Ride-Thru 1] and you do KEB Auto-Tuning, the drive will automatically set  $C1-09$ . If you must not change the Fast Stop time, do not do KEB Auto-Tuning.

The Fast Stop function will be triggered in the following circumstances.

- The Fast Stop operation will be triggered by the input of the Fast Stop command via the multi-function digital input terminal.
- The Fast Stop operation is will be triggered when by the input of the Fast Stop command is input via the multi-function digital input terminal.

Set  $H1-xx = 15, 17$  [MFDI Function Select = Fast Stop (N.O.), Fast Stop (N.C.)].

When the Fast Stop command is input, the Fast Stop operation will be triggered at the deceleration time set to  $C1-09$ . The drive cannot be restarted after initiating a Fast Stop operation until deceleration is complete. Complete deceleration and cycle the Run command to clear the Fast Stop input.

The terminal set for  $H2-xx = 4C$  [MFDO Function Select = During Fast Stop] will be ON during Fast Stop.

**Note:**

Decelerating too quickly can cause an *ov* [Overvoltage] fault that shuts off the drive while the motor to coasts to a stop. Set a Fast Stop time in  $C1-09$  that prevents motor coasting and makes sure that the motor stops quickly and safely.

### ■ C1-10: Accel/Decel Time Setting Units

| No. (Hex.)      | Name                           | Description   | Default (Range) |
|-----------------|--------------------------------|---|-----------------|
| C1-10<br>(0209) | Accel/Decel Time Setting Units | <b>V/f</b> <b>CL-V/f</b> <b>OLV</b> <b>CLV</b> <b>AOLV</b> <b>OLV/PM</b> <b>AOLV/PM</b> <b>CLV/PM</b> <b>EZOLV</b><br>Sets the setting units for $C1-01$ to $C1-08$ [Accel/Decel Times 1 to 4], $C1-09$ [Fast Stop Time], $L2-06$ [Kinetic Energy Backup Decel Time], and $L2-07$ [Kinetic Energy Backup Accel Time]. | 1<br>(0, 1)     |

#### 0 : 0.01 s (0.00 to 600.00 s)

Sets acceleration and deceleration times in 0.01 s units. The setting range is 0.0 to 6000.0 s.

If one of these parameters is set to 1000.0 s or longer, you cannot set  $C1-10 = 0$ :

- $C1-01$  to  $C1-09$



- L2-06
- L2-07

When one of those parameters is set to a value between 600.1 s and 1000.0 s, you can set  $C1-10 = 0$ , but the time will change to 600.00 s.

### 1 : 0.1 s (0.0 to 6000.0 s)

Sets acceleration and deceleration times in 0.1 s units. The setting range is 0.0 to 6000.0 s.

## ■ C1-11: Accel/Decel Time Switchover Freq

| No. (Hex.)   | Name                                 | Description   | Default (Range)                      |
|--------------|--------------------------------------|---|--------------------------------------|
| C1-11 (020A) | Accel/Decel Time Switching Frequency | V/f CL-V/f OLV CLV AOLV OLV/PM AOLV/PM CLV/PM EZOLV<br>Sets the frequency at which the drive will automatically change acceleration and deceleration times. | Determined by A1-02 (0.0 - 590.0 Hz) |

When output frequency get  $C1-11$  value, the drive automatically switches the acceleration and deceleration times. Set this parameter to  $0.0$  to disable this function.

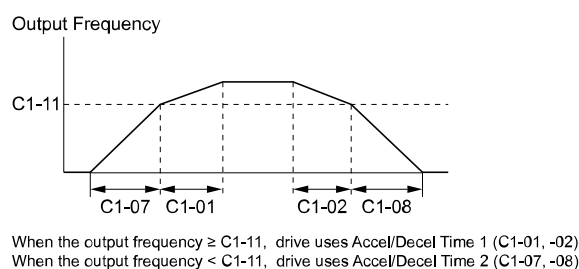


Figure 2.46 Accel/Decel Time Switching Frequency

Table 2.31 lists the possible combinations of acceleration and deceleration time switchover frequencies and the acceleration times for the Motor 2 Selection function.

Table 2.31 Motor and Acceleration and Deceleration Time Combination

| C1-11                                   | Motor 1                     |                             | Motor 2                     |                             |
|---|-----------------------------|-----------------------------|-----------------------------|-----------------------------|
|   | Acceleration Time           | Deceleration Time           | Acceleration Time           | Deceleration Time           |
| Less than the setting value             | C1-07 [Acceleration Time 4] | C1-08 [Deceleration Time 4] | C1-07 [Acceleration Time 4] | C1-08 [Deceleration Time 4] |
| Equal to or more than the setting value | C1-01 [Acceleration Time 1] | C1-02 [Deceleration Time 1] | C1-05 [Acceleration Time 3] | C1-06 [Deceleration Time 3] |

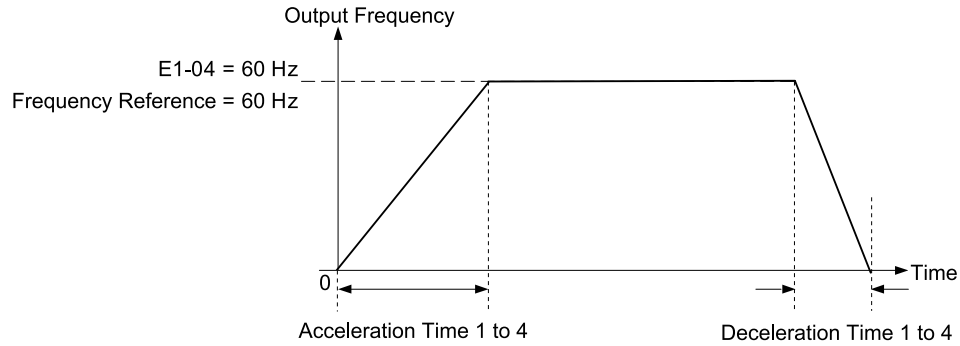
## ■ C1-14: Accel/Decel Rate Frequency

| No. (Hex.)       | Name                       | Description   | Default (Range)         |
|------------------|----------------------------|---|-------------------------|
| C1-14 (0264) RUN | Accel/Decel Rate Frequency | V/f CL-V/f OLV CLV AOLV OLV/PM AOLV/PM CLV/PM EZOLV<br>Sets the base frequency used to calculate acceleration and deceleration rates. | 0.0 Hz (0.0 - 590.0 Hz) |

The acceleration and deceleration rates set in  $C1-01$  to  $C1-09$  [Acceleration/Deceleration Times 1 to 4, Fast Stop Time] will change when the value of  $C1-14$  changes.

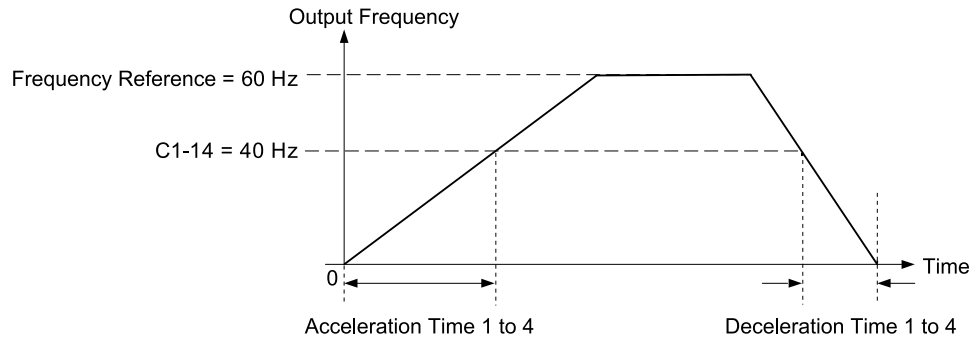
- When  $C1-14 = 0.0$  Hz
  - $C1-01$ ,  $C1-03$ ,  $C1-05$ ,  $C1-07$  [Acceleration Times 1 to 4]: Time to accelerate from 0 Hz to  $E1-04$  [Maximum Output Frequency]
  - $C1-02$ ,  $C1-04$ ,  $C1-06$ ,  $C1-08$  [Deceleration Times 1 to 4],  $C1-09$  [Fast Stop Time]: Time to decelerate from  $E1-04$  to 0 Hz.

## 2.4 C: Tuning

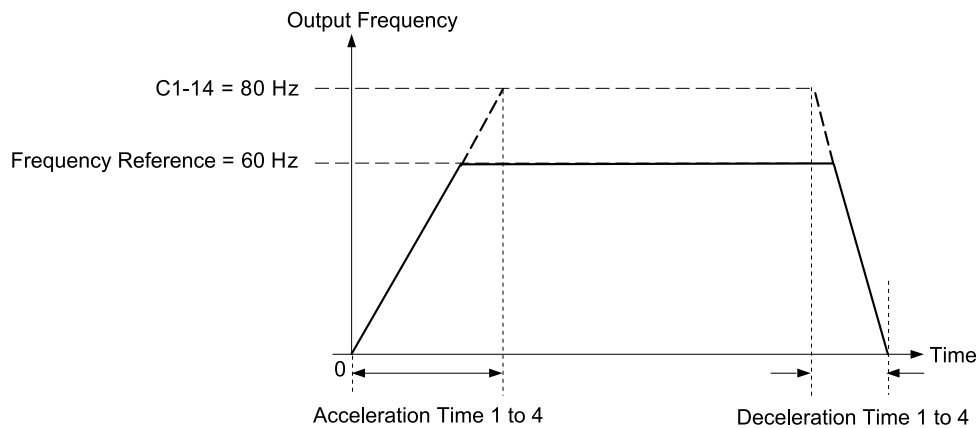


**Figure 2.47 Example 1: Acceleration/Deceleration Rate (When C1-14 = 0 Hz, E1-04 = 60 Hz, and the Frequency Reference is 60 Hz)**

- When  $C1-14 \neq 0.0$  Hz
  - C1-01, C1-03, C1-05, C1-07: Time to accelerate from 0 Hz to C1-14
  - C1-02, C1-04, C1-06, C1-08, C1-09: Time to decelerate from C1-14 to 0 Hz



**Figure 2.48 Example 2: Acceleration/Deceleration Rate (When C1-14 = 40 Hz, E1-04 = 60 Hz, and the Frequency Reference is 60 Hz)**



**Figure 2.49 Example 3: Acceleration/Deceleration Rate (When C1-14 = 80 Hz, E1-04 = 60 Hz, and the Frequency Reference is 60 Hz)**

**Note:**

- Figure 2.47 to Figure 2.49 show the accel/decel times when C2-01 to C2-04 [S-Curve Times @ Start/End of Accel/Decel] = 0.00 s.
- When L3-01  $\neq 0$  [Stall Prevention during Accel  $\neq$  Disabled], Stall Prevention could cause the acceleration time to be longer than the set value.
- When L3-04  $\neq 0$  [Stall Prevention during Decel  $\neq$  Disabled], Stall Prevention could cause the deceleration time to be longer than the set value.

### ◆ C2: S-Curve Characteristics

Use S-curve characteristics to smooth acceleration and deceleration and to minimize abrupt shock to the load.

Set S-curve characteristic time during acceleration/deceleration at start and acceleration/deceleration at stop. The following figure explains how S-curves are applied.

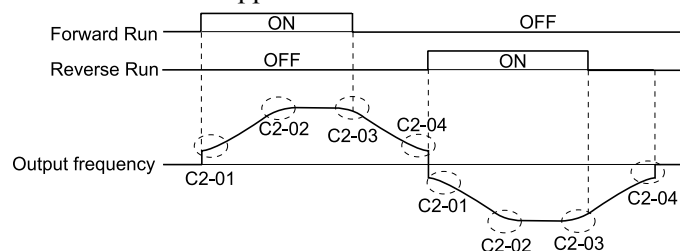


Figure 2.50 S-Curve Timing Diagram - Forward/Reverse Operation

**Note:**

- If *STPo* [Motor Step-Out Detected] occurs when starting a PM motor, try increasing the value set to *C2-01*.
- Setting the S-curve will increase the acceleration and deceleration times.

$$\text{Acceleration time} = \text{Selected acceleration time} + \frac{C2-01 + C2-02}{2}$$

$$\text{Deceleration time} = \text{Selected deceleration time} + \frac{C2-03 + C2-04}{2}$$

### ■ C2-01: S-Curve Time @ Start of Accel

| No. (Hex.)   | Name                          | Description  | Default (Range)                      |
|--------------|-------------------------------|--|--------------------------------------|
| C2-01 (020B) | S-Curve Time @ Start of Accel | <input type="checkbox"/> V/f <input type="checkbox"/> CL-V/f <input type="checkbox"/> OLV <input type="checkbox"/> CLV <input type="checkbox"/> AOLV <input type="checkbox"/> OLV/PM <input type="checkbox"/> AOLV/PM <input type="checkbox"/> CLV/PM <input type="checkbox"/> EZOLV<br>Sets the S-curve acceleration time at start. | Determined by A1-02 (0.00 - 10.00 s) |

### ■ C2-02: S-Curve Time @ End of Accel

| No. (Hex.)   | Name                        | Description   | Default (Range)         |
|--------------|-----------------------------|---|-------------------------|
| C2-02 (020C) | S-Curve Time @ End of Accel | <input type="checkbox"/> V/f <input type="checkbox"/> CL-V/f <input type="checkbox"/> OLV <input type="checkbox"/> CLV <input type="checkbox"/> AOLV <input type="checkbox"/> OLV/PM <input type="checkbox"/> AOLV/PM <input type="checkbox"/> CLV/PM <input type="checkbox"/> EZOLV<br>Sets the S-curve acceleration time at completion. | 0.20 s (0.00 - 10.00 s) |

### ■ C2-03: S-Curve Time @ Start of Decel

| No. (Hex.)   | Name                          | Description  | Default (Range)         |
|--------------|-------------------------------|--|-------------------------|
| C2-03 (020D) | S-Curve Time @ Start of Decel | <input type="checkbox"/> V/f <input type="checkbox"/> CL-V/f <input type="checkbox"/> OLV <input type="checkbox"/> CLV <input type="checkbox"/> AOLV <input type="checkbox"/> OLV/PM <input type="checkbox"/> AOLV/PM <input type="checkbox"/> CLV/PM <input type="checkbox"/> EZOLV<br>Sets the S-curve deceleration time at start. | 0.20 s (0.00 - 10.00 s) |

### ■ C2-04: S-Curve Time @ End of Decel

| No. (Hex.)   | Name                        | Description   | Default (Range)         |
|--------------|-----------------------------|---|-------------------------|
| C2-04 (020E) | S-Curve Time @ End of Decel | <input type="checkbox"/> V/f <input type="checkbox"/> CL-V/f <input type="checkbox"/> OLV <input type="checkbox"/> CLV <input type="checkbox"/> AOLV <input type="checkbox"/> OLV/PM <input type="checkbox"/> AOLV/PM <input type="checkbox"/> CLV/PM <input type="checkbox"/> EZOLV<br>Sets the S-curve deceleration time at completion. | 0.00 s (0.00 - 10.00 s) |

## ◆ C3: Slip Compensation

The Slip Compensation function improves the speed accuracy of an induction motor. As loads on induction motors increase, motor slip increases and motor speed decreases. By adjusting the output frequency in accordance with the motor load, it compensates the slip and makes the motor speed equal to the frequency reference.

## 2.4 C: Tuning

### ■ C3-01: Slip Compensation Gain

| No. (Hex.)             | Name                   | Description   | Default (Range)                    |
|------------------------|------------------------|---|------------------------------------|
| C3-01<br>(020F)<br>RUN | Slip Compensation Gain | <div style="display: flex; gap: 5px;"> <span>V/f</span> <span>CL-V/f</span> <span>OLV</span> <span>CLV</span> <span>AOLV</span> <span>OLV/PM</span> <span>AOLV/PM</span> <span>CLV/PM</span> <span>EZOLV</span> </div> <p>Sets the gain for the slip compensation function. Usually it is not necessary to change this setting.</p> | Determined by A1-02<br>(0.0 - 2.5) |

**Note:**

- Correctly set these parameters before changing the slip compensation gain:
  - E2-01 [Motor Rated Current (FLA)]
  - E2-02 [Motor Rated Slip]
  - E2-03 [Motor No-Load Current]
- When  $A1-02 = 3 [CLV]$ , the slip compensation gain becomes the motor temperature compensation gain. When the motor temperature increases, the motor internal constant changes and increases the slip. When you set this parameter, the drive adjusts the slip with the increase in temperature. Adjust this parameter in these conditions: When the setting value increases, the compensation also increases:
  - The drive is doing torque control.
  - There are torque limits.
  - Output torque changes when the temperature changes.

Use these settings to adjust this parameter as necessary:

- If the motor speed is slower than the frequency reference, increase C3-01 in 0.1 unit increments.
- If the motor speed is higher than the frequency reference, decrease the setting of this parameter in increments of 0.1.

### ■ C3-02: Slip Compensation Delay Time

| No. (Hex.)             | Name                         | Description  | Default (Range)                       |
|------------------------|------------------------------|--|---------------------------------------|
| C3-02<br>(0210)<br>RUN | Slip Compensation Delay Time | <div style="display: flex; gap: 5px;"> <span>V/f</span> <span>CL-V/f</span> <span>OLV</span> <span>CLV</span> <span>AOLV</span> <span>OLV/PM</span> <span>AOLV/PM</span> <span>CLV/PM</span> <span>EZOLV</span> </div> <p>Sets the slip compensation delay time when speed is unstable or when the slip compensation response is too slow. Usually it is not necessary to change this setting.</p> | Determined by A1-02<br>(0 - 10000 ms) |

Use these settings to adjust this parameter as necessary:

- When the speed is not stable, increase the setting.
- When the slip compensation response is too slow, decrease the setting.

### ■ C3-03: Slip Compensation Limit

| No. (Hex.)      | Name                    | Description  | Default (Range)    |
|-----------------|-------------------------|--|--------------------|
| C3-03<br>(0211) | Slip Compensation Limit | <div style="display: flex; gap: 5px;"> <span>V/f</span> <span>CL-V/f</span> <span>OLV</span> <span>CLV</span> <span>AOLV</span> <span>OLV/PM</span> <span>AOLV/PM</span> <span>CLV/PM</span> <span>EZOLV</span> </div> <p>Sets the upper limit for the slip compensation function as a percentage of the motor rated slip.</p> | 200%<br>(0 - 250%) |

If you increase the value of C3-01 [Slip Compensation Gain] and the motor speed is slow, use this parameter. The drive uses this parameter when the slip is at the upper limit of slip compensation. Make sure that you measure the motor speed when you increase this parameter value. Set this parameter to make the frequency reference and the slip compensation limit less than the permitted range of the machine.

The slip compensation limit is constant in the constant torque range (frequency reference  $\leq E1-06$  [Base Frequency]). In the constant output range where the frequency reference  $> E1-06$ , the slip compensation limit increases with the C3-03 value and the output frequency as shown in Figure 2.51.

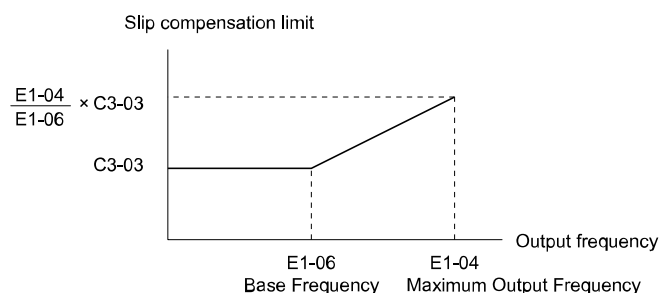


Figure 2.51 Slip Compensation Limit

### ■ C3-04: Slip Compensation at Regen

| No. (Hex.)   | Name                       | Description   | Default (Range) |
|--------------|----------------------------|---|-----------------|
| C3-04 (0212) | Slip Compensation at Regen | <input type="checkbox"/> V/f <input type="checkbox"/> CL-V/f <input checked="" type="checkbox"/> OLV <input type="checkbox"/> CLV <input type="checkbox"/> AOLV <input type="checkbox"/> OLV/PM <input type="checkbox"/> AOLV/PM <input type="checkbox"/> CLV/PM <input type="checkbox"/> EZOLV<br>Sets the slip compensation function during regenerative operation. | 0<br>(0 - 2)    |

If you apply a regenerative load when slip compensation during regeneration is active, the regeneration amount may instantaneously increase and it can be necessary to use a dynamic braking option (braking resistor or braking resistor unit).

#### 0 : Disabled

The drive does not provide slip compensation during regeneration.

The load and operation status (regenerative operation) can cause the motor speed to be higher or lower than the frequency reference.

#### 1 : Enabled Above 6Hz

Slip compensation function is enabled during regeneration. Slip compensation is disabled at output frequencies of 6 Hz or less.

#### 2 : Enabled Above C3-15

The drive uses *E2-02 [Motor Rated Slip]* to automatically calculate the frequency range where it will disable slip compensation function during regenerative operation.

Slip compensation is enabled at frequencies as low as 2 Hz.

### ■ C3-05: Output Voltage Limit Selection

| No. (Hex.)   | Name                           | Description  | Default (Range) |
|--------------|--------------------------------|--|-----------------|
| C3-05 (0213) | Output Voltage Limit Selection | <input type="checkbox"/> V/f <input type="checkbox"/> CL-V/f <input checked="" type="checkbox"/> OLV <input type="checkbox"/> CLV <input type="checkbox"/> AOLV <input type="checkbox"/> OLV/PM <input type="checkbox"/> AOLV/PM <input type="checkbox"/> CLV/PM <input type="checkbox"/> EZOLV<br>Sets the automatic reduction of motor magnetic flux when the output voltage is saturated. | 0<br>(0, 1)     |

The drive will decrease flux and increase current to compensate torque when voltage is in saturation state. Make sure that the drive has sufficient output current capacity before you enable this parameter. When this parameter is set to *1 [Enabled]*, the output current will increase by 10% at a maximum (at rated load) than before it is enabled.

Enable this parameter to increase speed precision when you move heavy loads at high speeds in these conditions:

- Power supply voltage is low
- Motor rated voltage is high

Do not enable this parameter in these conditions:

- Operating a motor in the middle speed range or low speed range
- Power supply voltage is a minimum of 10% more than the motor rated voltage

When this parameter is enabled, you could possibly not have accurate torque control if the power supply voltage is much less than the motor rated voltage.

#### 0 : Disabled

#### 1 : Enabled

## 2.4 C: Tuning

### ■ C3-16: Vout Modulation Limit Start Lvl

| No. (Hex.)                | Name                            | Description   | Default (Range)         |
|---------------------------|---------------------------------|---|-------------------------|
| C3-16<br>(0261)<br>Expert | Vout Modulation Limit Start Lvl | <input type="checkbox"/> V/f <input type="checkbox"/> CL-V/f <input checked="" type="checkbox"/> OLV <input type="checkbox"/> CLV <input type="checkbox"/> AOLV <input type="checkbox"/> OLV/PM <input type="checkbox"/> AOLV/PM <input type="checkbox"/> CLV/PM <input type="checkbox"/> EZOLV<br>Sets the modulation factor that starts the output voltage limit operation when C3-05 = 1 [Output Voltage Limit Selection = Enabled]. | 90.0%<br>(70.0 - 90.0%) |

### ■ C3-17: Vout Modulation Limit Max Level

| No. (Hex.)                | Name                            | Description  | Default (Range)           |
|---------------------------|---------------------------------|--|---------------------------|
| C3-17<br>(0262)<br>Expert | Vout Modulation Limit Max Level | <input type="checkbox"/> V/f <input type="checkbox"/> CL-V/f <input checked="" type="checkbox"/> OLV <input type="checkbox"/> CLV <input type="checkbox"/> AOLV <input type="checkbox"/> OLV/PM <input type="checkbox"/> AOLV/PM <input type="checkbox"/> CLV/PM <input type="checkbox"/> EZOLV<br>Sets the modulation factor used with C3-18 [Output Voltage Limit Level] for the output voltage limit operation when C3-05 = 1 [Output Voltage Limit Selection = Enabled]. | 100.0%<br>(85.0 - 100.0%) |

### ■ C3-18: Output Voltage Limit Level

| No. (Hex.)                | Name                       | Description  | Default (Range)          |
|---------------------------|----------------------------|--|--------------------------|
| C3-18<br>(0263)<br>Expert | Output Voltage Limit Level | <input type="checkbox"/> V/f <input type="checkbox"/> CL-V/f <input checked="" type="checkbox"/> OLV <input type="checkbox"/> CLV <input type="checkbox"/> AOLV <input type="checkbox"/> OLV/PM <input type="checkbox"/> AOLV/PM <input type="checkbox"/> CLV/PM <input type="checkbox"/> EZOLV<br>Sets the maximum drop width of the voltage reference when C3-05 = 1 [Output Voltage Limit Selection = Enabled]. | 90.0%<br>(50.0 - 100.0%) |

### ■ C3-21: Motor 2 Slip Compensation Gain

| No. (Hex.)             | Name                           | Description  | Default (Range)                    |
|------------------------|--------------------------------|--|------------------------------------|
| C3-21<br>(033E)<br>RUN | Motor 2 Slip Compensation Gain | <input type="checkbox"/> V/f <input type="checkbox"/> CL-V/f <input checked="" type="checkbox"/> OLV <input type="checkbox"/> CLV <input type="checkbox"/> AOLV <input type="checkbox"/> OLV/PM <input type="checkbox"/> AOLV/PM <input type="checkbox"/> CLV/PM <input type="checkbox"/> EZOLV<br>Sets the gain for the motor 2 slip compensation function. Usually it is not necessary to change this setting. | Determined by E3-01<br>(0.0 - 2.5) |

**Note:**

Correctly set these parameters before changing the slip compensation gain:

- E4-01 [Motor 2 Rated Current]
- E4-02 [Motor 2 Rated Slip]
- E4-03 [Motor 2 Rated No-Load Current]

Use these settings to adjust this parameter as necessary:

- If the motor speed is slower than the frequency reference, increase C3-01 in 0.1 unit increments.
- If the motor speed is higher than the frequency reference, decrease the setting of this parameter in increments of 0.1.

### ■ C3-22: Motor 2 Slip Comp Delay Time

| No. (Hex.)             | Name                         | Description  | Default (Range)                       |
|------------------------|------------------------------|--|---------------------------------------|
| C3-22<br>(0241)<br>RUN | Motor 2 Slip Comp Delay Time | <input checked="" type="checkbox"/> V/f <input type="checkbox"/> CL-V/f <input checked="" type="checkbox"/> OLV <input type="checkbox"/> CLV <input type="checkbox"/> AOLV <input type="checkbox"/> OLV/PM <input type="checkbox"/> AOLV/PM <input type="checkbox"/> CLV/PM <input type="checkbox"/> EZOLV<br>Sets the slip compensation delay time for motor 2 when speed is unstable or when the slip compensation response is too slow. Usually it is not necessary to change this setting. | Determined by E3-01<br>(0 - 10000 ms) |

Use these settings to adjust this parameter as necessary:

- When the speed is not stable, increase the setting.
- When the slip compensation response is too slow, decrease the setting.

### ■ C3-23: Motor 2 Slip Compensation Limit

| No. (Hex.)      | Name                            | Description   | Default (Range)    |
|-----------------|---------------------------------|---|--------------------|
| C3-23<br>(0242) | Motor 2 Slip Compensation Limit | <input type="checkbox"/> V/f <input type="checkbox"/> CL-V/f <input checked="" type="checkbox"/> OLV <input type="checkbox"/> CLV <input type="checkbox"/> AOLV <input type="checkbox"/> OLV/PM <input type="checkbox"/> AOLV/PM <input type="checkbox"/> CLV/PM <input type="checkbox"/> EZOLV<br>Sets the upper limit for the slip compensation function as a percentage of the motor 2 rated slip. | 200%<br>(0 - 250%) |

If you increase the value of *C3-21 [Motor 2 Slip Compensation Gain]* and the motor speed is slow, use this parameter. The drive uses this parameter when the slip is at the upper limit of slip compensation. Make sure that you measure the motor speed when you increase this parameter value. Set this parameter to make the frequency reference and the slip compensation limit less than the permitted range of the machine.

The slip compensation limit is constant in the constant torque range (frequency reference  $\leq E3-06$  [*Motor 2 Base Frequency*]). In the constant power range where the frequency reference  $> E3-06$ , the slip compensation limit increases with the *C3-23* value and the output frequency as shown in Figure 2.52.

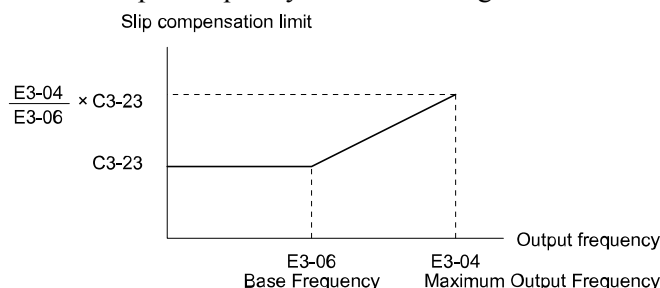


Figure 2.52 Motor 2 Slip Compensation Limit

### ■ C3-24: Motor 2 Slip Comp during Regen

| No. (Hex.)   | Name                           | Description  | Default (Range) |
|--------------|--------------------------------|--|-----------------|
| C3-24 (0243) | Motor 2 Slip Comp during Regen | <input type="checkbox"/> V/f <input type="checkbox"/> CL-V/f <input type="checkbox"/> OLV <input type="checkbox"/> CLV <input type="checkbox"/> AOLV <input type="checkbox"/> OLV/PM <input type="checkbox"/> AOLV/PM <input type="checkbox"/> CLV/PM <input type="checkbox"/> EZOLV<br>Sets the slip compensation during regenerative operation function for motor 2. | 0<br>(0 - 2)    |

If you enable the slip compensation function during regeneration, the regeneration amount may instantaneously increase, making it necessary to use a dynamic braking option (braking resistor or braking resistor unit).

#### 0 : No

Slip compensation is not performed during regeneration.

The load and operation status (regenerative operation) can cause the motor speed to be higher or lower than the frequency reference.

#### 1 : Enabled Above 6Hz

The slip compensation function is enabled during regeneration. Slip compensation is disabled at output frequencies of 6 Hz or less.

#### 2 : Enabled Above C3-15

The drive uses *E2-02 [Motor Rated Slip]* to automatically calculate the frequency range where it will disable slip compensation function during regenerative operation.

Slip compensation is enabled at frequencies as low as 2 Hz.

### ■ C3-28: Adaptive Slip Control Mode

| No. (Hex.)          | Name                       | Description  | Default (Range) |
|---------------------|----------------------------|--|-----------------|
| C3-28 (1B5B) Expert | Adaptive Slip Control Mode | <input type="checkbox"/> V/f <input type="checkbox"/> CL-V/f <input type="checkbox"/> OLV <input checked="" type="checkbox"/> CLV <input type="checkbox"/> AOLV <input type="checkbox"/> OLV/PM <input type="checkbox"/> AOLV/PM <input type="checkbox"/> CLV/PM <input type="checkbox"/> EZOLV<br>Sets the slip compensation function mode. | 0<br>(0, 1)     |

#### 0 : Normal

#### 1 : Advanced

##### Note:

Set *C3-28 = 0* for better torque precision. If the torque precision does is not better, set *C3-28 = 1* and increase the value of *n4-65 [Flux Estimate Response@High Freq]* or *n4-66 [Flux Estimate Response @Low Freq]* in 0.1-unit increments. Then, you must do Rotational Auto-Tuning.

### ◆ C4: Torque Compensation

Torque compensation is a function that increases voltage to increase output torque as compensation for insufficient torque production at start-up or low-speed operation.

Voltage drops due to motor winding resistance cause torque generating voltage to decrease, which causes insufficient torque. If the main circuit cable connecting the drive and motor is long, this can also cause insufficient torque due to voltage drops.

**Note:**

Set the motor parameters and V/f pattern properly before setting *C4 parameters*.

#### ■ C4-01: Torque Compensation Gain

| No. (Hex.)             | Name                     | Description  | Default (Range)                      |
|------------------------|--------------------------|--|--------------------------------------|
| C4-01<br>(0215)<br>RUN | Torque Compensation Gain | <div style="display: flex; justify-content: space-between; font-size: 0.8em;"> <span>V/f</span> <span>CL-V/f</span> <span>OLV</span> <span>CLV</span> <span>AOLV</span> <span>OLV/PM</span> <span>AOLV/PM</span> <span>CLV/PM</span> <span>EZOLV</span> </div> <p>Sets the gain for the torque compensation function. Use this parameter value for motor 1 when operating multiple motors.</p> | Determined by A1-02<br>(0.00 - 2.50) |

Adjust the setting when in the following control method and state.

| A1-02 [Control Method Selection]   | Status  | Adjustment                                  |
|--|---|---|
| 0 [V/f Control]<br>1 [V/f Control with Encoder]<br>8 [EZ Vector Control] | Torque is not sufficient during low-speed operation of 10 Hz or less.       | Increase the setting in increments of 0.05. |
|  | There is vibration in the motor when operating the drive with a light load. | Decrease the setting in decrements of 0.05. |
|  | The cable between the drive and motor is too long.                          | Increase the setting in increments of 0.05. |

**Note:**

- Adjust C4-01 to the extent that the output current is not more than the drive rated current during low-speed operation.
- When A1-02 = 2 [Open Loop Vector], normally do not change the setting. Failure to observe this could worsen the torque precision.
- When A1-02 = 5 [PM Open Loop Vector], normally do not change the setting. Setting this value too high can cause overcompensation and motor oscillation.
- When A1-02 = 8 [EZ Open Loop Vector Control], you cannot change the setting while the drive is running.

#### ■ C4-02: Torque Compensation Delay Time

| No. (Hex.)             | Name                           | Description  | Default (Range)                       |
|------------------------|--------------------------------|--|---------------------------------------|
| C4-02<br>(0216)<br>RUN | Torque Compensation Delay Time | <div style="display: flex; justify-content: space-between; font-size: 0.8em;"> <span>V/f</span> <span>CL-V/f</span> <span>OLV</span> <span>CLV</span> <span>AOLV</span> <span>OLV/PM</span> <span>AOLV/PM</span> <span>CLV/PM</span> <span>EZOLV</span> </div> <p>Sets the torque compensation delay time. Usually it is not necessary to change this setting.</p> | Determined by A1-02<br>(0 - 60000 ms) |

**Note:**

If A1-02 = 8 [Control Method Selection = EZOLV], you cannot change the setting while the drive is running.

As needed, set this parameter as shown below.

- If there is vibration in the motor, increase the setting.
- If the motor speed or motor torque response is too slow, decrease the setting.

#### ■ C4-03: Torque Compensation @ FWD Start

| No. (Hex.)      | Name                            | Description   | Default (Range)        |
|-----------------|---------------------------------|---|------------------------|
| C4-03<br>(0217) | Torque Compensation @ FWD Start | <div style="display: flex; justify-content: space-between; font-size: 0.8em;"> <span>V/f</span> <span>CL-V/f</span> <span>OLV</span> <span>CLV</span> <span>AOLV</span> <span>OLV/PM</span> <span>AOLV/PM</span> <span>CLV/PM</span> <span>EZOLV</span> </div> <p>Set the amount of torque reference for forward start as a percentage of the motor rated torque.</p> | 0.0%<br>(0.0 - 200.0%) |

The torque compensation function is performed using the time constant set in C4-05 [Torque Compensation Time]. This is available only when starting the motor with the forward command. Set this parameter to 0.0 to disable this function.



### ■ C4-04: Torque Compensation @ REV Start

| No. (Hex.)   | Name                            | Description  | Default (Range)         |
|--------------|---------------------------------|--|-------------------------|
| C4-04 (0218) | Torque Compensation @ REV Start | V/f CL-V/f <b>OLV</b> CLV AOLV OLV/PM AOLV/PM CLV/PM EZOLV<br>Sets the amount of torque reference for reverse start as a percentage of the motor rated torque. | 0.0%<br>(-200.0 - 0.0%) |

The torque compensation function is performed using the time constant set in *C4-05 [Torque Compensation Time]*. This is available only when starting the motor with the reverse run command.

### ■ C4-05: Torque Compensation Time

| No. (Hex.)   | Name                     | Description   | Default (Range)       |
|--------------|--------------------------|---|-----------------------|
| C4-05 (0219) | Torque Compensation Time | V/f CL-V/f <b>OLV</b> CLV AOLV OLV/PM AOLV/PM CLV/PM EZOLV<br>Sets the starting torque constant to use with <i>C4-03</i> and <i>C4-04 [Torque Compensation @ FWD/REV Start]</i> . | 10 ms<br>(0 - 200 ms) |

### ■ C4-06: Motor 2 Torque Comp Delay Time

| No. (Hex.)   | Name                           | Description  | Default (Range)          |
|--------------|--------------------------------|--|--------------------------|
| C4-06 (021A) | Motor 2 Torque Comp Delay Time | V/f CL-V/f <b>OLV</b> CLV AOLV OLV/PM AOLV/PM CLV/PM EZOLV<br>Sets the value if <i>ov</i> [Overvoltage] occurs with sudden changes in the load, at the end of acceleration, or at the start of deceleration. | 150 ms<br>(0 - 10000 ms) |

Sets the time constant used during Speed Search or during regenerative operation when *ov* occurs.

Adjust this parameter in the following circumstances.

- Gradually reduce the setting in 10 ms increments and check the performance to improve motor torque speed response when *ov* occurs.

**Note:**

- Ensure that  $C4-06 \geq C4-02$  [Torque Compensation Delay Time].
- Increase the setting value of *n2-03 [Automatic Freq Regulator Time 2]* proportional to *C4-06*.

### ■ C4-07: Motor 2 Torque Compensation Gain

| No. (Hex.)          | Name                             | Description  | Default (Range)       |
|---------------------|----------------------------------|--|-----------------------|
| C4-07 (0341)<br>RUN | Motor 2 Torque Compensation Gain | V/f CL-V/f <b>OLV</b> CLV AOLV OLV/PM AOLV/PM CLV/PM EZOLV<br>Sets the gain for motor 2 torque compensation function when using the Motor Switch function. | 1.00<br>(0.00 - 2.50) |

In V/f Control or CL-V/f Control, adjust the value in 0.05 unit increments for these conditions:

- When torque is not sufficient during low-speed operation of 10 Hz or less, increase the setting value
- When there is vibration in the motor or when the motor hunts when operating the drive with a light load, decrease the setting value
- When you are using a long motor cable, increase the setting.

**Note:**

- Adjust *C4-07* to the extent that the output current is not more than the drive rated current during low-speed operation.
- When  $A1-02 = 2$  [Control Method Selection = *OLV*], normally do not change the setting. Failure to observe this could worsen the torque precision.

### ■ C4-19: Torque Ripple Suppress Min Freq

| No. (Hex.)             | Name                            | Description  | Default (Range)           |
|------------------------|---------------------------------|--|---------------------------|
| C4-19 (0B8D)<br>Expert | Torque Ripple Suppress Min Freq | V/f CL-V/f <b>OLV</b> CLV AOLV OLV/PM AOLV/PM CLV/PM EZOLV<br>Adjust this if a slow oscillation occurs at low speeds. Increase this parameter in 1.0 Hz increments when current ripples and torque ripples occur during low-speed operation. Set this parameter to 0.0 to disable the function if increasing the value does not fix the problem. Usually it is not necessary to change this setting. | 0.1 Hz<br>(0.0 - 10.0 Hz) |

## 2.4 C: Tuning

**Note:**

Set C4-20 [Voltage Compensation Adjust 1]  $\neq 0$  to enable this parameter.

### ■ C4-20: Voltage Compensation Adjust 1

| No. (Hex.)                | Name                          | Description  | Default (Range)  |
|---------------------------|-------------------------------|--|------------------|
| C4-20<br>(0BCB)<br>Expert | Voltage Compensation Adjust 1 | <b>V/f</b> <b>CL-V/f</b> <b>OLV</b> <b>CLV</b> <b>AOLV</b> <b>OLV/PM</b> <b>AOLV/PM</b> <b>CLV/PM</b> <b>EZOLV</b><br>Sets voltage precision compensation. Usually it is not necessary to change this setting. | 120<br>(0 - 200) |

**Note:**

Set C4-20 = 0 when noise occurs during low-speed operation.

### ■ C4-21: Voltage Compensation Adjust 2

| No. (Hex.)                | Name                          | Description  | Default (Range) |
|---------------------------|-------------------------------|--|-----------------|
| C4-21<br>(0BCC)<br>Expert | Voltage Compensation Adjust 2 | <b>V/f</b> <b>CL-V/f</b> <b>OLV</b> <b>CLV</b> <b>AOLV</b> <b>OLV/PM</b> <b>AOLV/PM</b> <b>CLV/PM</b> <b>EZOLV</b><br>Sets voltage precision compensation. Usually it is not necessary to change this setting. | 5<br>(0 - 10)   |

**Note:**

Set C4-21 = 0 when noise occurs during high-speed operation.

### ■ C4-23: Current Control Gain

| No. (Hex.)                       | Name                 | Description   | Default (Range)       |
|----------------------------------|----------------------|---|-----------------------|
| C4-23<br>(1583)<br>RUN<br>Expert | Current Control Gain | <b>V/f</b> <b>CL-V/f</b> <b>OLV</b> <b>CLV</b> <b>AOLV</b> <b>OLV/PM</b> <b>AOLV/PM</b> <b>CLV/PM</b> <b>EZOLV</b><br>Current control gain. Usually it is not necessary to change this parameter. | 1.00<br>(0.50 - 2.50) |

## ◆ C5: Speed control (ASR: Automatic Speed Regulator)

The ASR adjusts the output frequency or torque reference to decrease the difference between frequency reference and motor speed. The control method sets the parameter that you must adjust.

| A1-02 [Control Method Selection]   | Targets of Adjustment |
|--|-----------------------|
| 1: Closed Loop V/f Control (CL-V/f)  | Output Frequency      |
| <ul style="list-style-type: none"> <li>3: Closed Loop Vector Control (CLV)</li> <li>4: Advanced Open Loop Vector Control (AOLV)</li> <li>6: PM Advanced Open Loop Vector (AOLV/PM)</li> <li>7: Closed Loop Vector Control for PM (CLV/PM)</li> <li>8: EZ Vector Control (EZOLV)</li> </ul> | Torque Reference      |

The speed control block diagrams of the respective control methods are shown in Figure 2.53 and Figure 2.54.

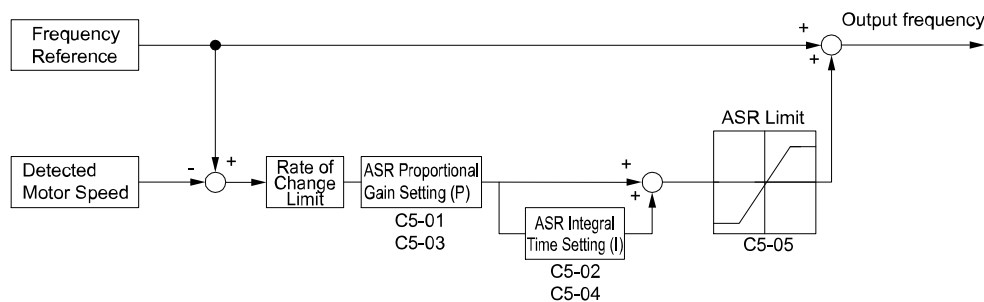


Figure 2.53 Speed control block diagram for CL-V/f

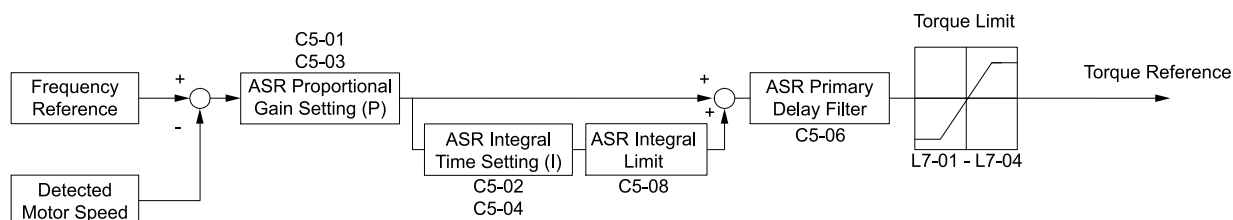


Figure 2.54 Speed control block diagrams for CLV, AOLV, CLV/PM, AOLV/PM, and EZOLV

**Note:**

The detected speed is the speed estimation value when configured such that  $A1-02 = 4, 6, \text{ or } 8$  [Control Method Selection = AOLV, AOLV/PM, or EZOLV].

### ■ Before You Adjust ASR Parameters

- Do Auto-Tuning and set up all motor data correctly.
- Always make adjustments with the load connected to the motor.
- Use analog output signals to monitor  $U1-16$  [SFS Output Frequency] and  $U1-05$  [Motor Speed] when you adjust the ASR.

### ■ ASR adjustment procedure for CL-V/f

Do this procedure to adjust ASR parameters:

1. Run the motor at minimum speed and increase  $C5-03$  [ASR Proportional Gain 2] as much as possible without oscillation.

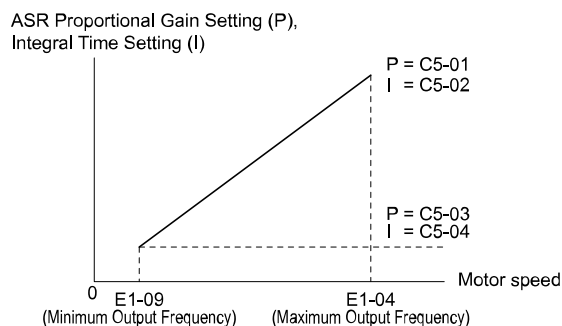


Figure 2.55 ASR Gain and Integral Time Adjustment

2. Run the motor at minimum speed and decrease  $C5-04$  [ASR Integral Time 2] as much as possible without oscillation.
3. Check the output current monitor to make sure that the output current is less than 50% of the drive rated current. If the setting value is higher than 50%, decrease  $C5-03$  and increase  $C5-04$ .
4. Run the motor at maximum speed and increase  $C5-01$  [ASR Proportional Gain 1] as much as possible without oscillations.
5. Run the motor at maximum speed and decrease  $C5-02$  [ASR Integral Time 1] as much as possible without oscillations.
6. If higher speed precision and faster response during acceleration or deceleration are necessary, set  $C5-12 = 1$  [Integral Operation @ Accel/Decel = Enabled] to enable integral control during acceleration/decel.

**Note:**

- If overshooting occurs when acceleration ends, decrease the value set in  $C5-01$  and increase the value set in  $C5-02$ .
- If undershoot occurs at stop, decrease  $C5-03$  and increase  $C5-04$ .
- If you adjust the gain and it does not correct overshooting and undershooting, decrease the value set in  $C5-05$  [ASR Limit] to decrease the upper limit of the frequency reference compensation.

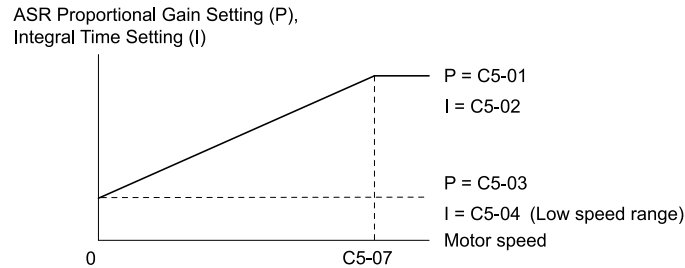
### ■ ASR adjustment procedure for CLV, AOLV, AOLV/PM, CLV/PM, and EZOLV

Do this procedure to adjust ASR parameters:

1. Run the motor at zero speed or low speed and increase  $C5-01$  [ASR Proportional Gain 1] until immediately before vibration starts to occur.

## 2.4 C: Tuning

2. Run the motor at zero speed or low speed and decrease *C5-02* [ASR Integral Time 1] until immediately before vibration starts to occur.
3. Check for oscillation when you run the motor at maximum speed.
4. If oscillation occurs, increase *C5-02* and decrease *C5-01*.  
When there is no oscillation, the adjustment procedure is complete.
5. Set the low-speed gain. Run the motor at zero speed or low speed and increase *C5-03* [ASR Proportional Gain 2] until immediately before vibration starts to occur.



**Figure 2.56 Low-speed/High-speed Gain Settings**

6. Set the low-speed integral time. Run the motor at zero speed or low speed and decrease *C5-04* [ASR Integral Time 2] until immediately before vibration starts to occur.
7. Set *C5-07* [ASR Gain Switchover Frequency].
8. Check for oscillation when you run the motor at speeds more than the setting in *C5-07*.

**Note:**

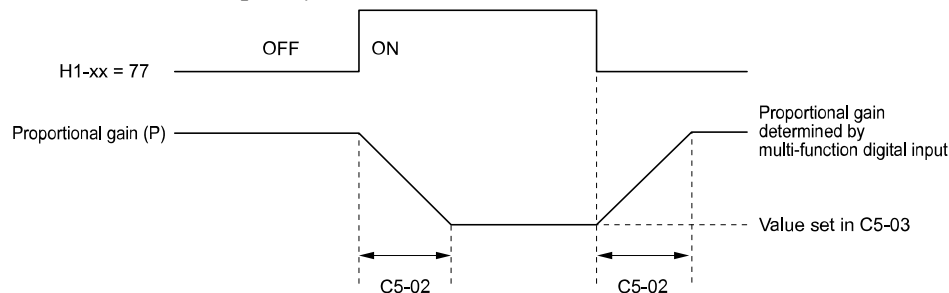
- If overshooting occurs when acceleration ends, decrease the value set in *C5-01* and increase the value set in *C5-02*.
- If undershoot occurs at stop, decrease *C5-03* and increase *C5-04*.

### ■ Use MFDI Switch for Proportional Gain

**Note:**

If *A1-02* = 1 [Control Method Selection = V/f Control with Encoder], you cannot use this function.

You can use the input terminals set for ASR Gain (*C5-03*) Select [*H1-xx* = 77] to switch the proportional gains set with *C5-01* and *C5-03*. When the configured input terminal is deactivated, the proportional gain set for *C5-01* is selected. When the terminal is activated, the proportional gain set for *C5-03* is selected. The proportional gain changes linearly over the time set in *C5-02* [ASR Integral Time 1]. The signals from this MFDI are more important than *C5-07* [ASR Gain Switchover Frequency].



**Figure 2.57 Proportional Gain through Multi-function Digital Input Switch**

### ■ Speed Waveform Monitoring Method

To make small adjustments of ASR parameters, monitor the speed waveforms when you make the adjustments. Table 2.32 shows example settings of parameters to monitor speed waveforms.

Table 2.32 Example Settings of MFAO Terminals to Monitor Speed Waveforms

| No.   | Name                             | Setting Value | Description   |
|-------|----------------------------------|---------------|---|
| H4-01 | Terminal FM Analog Output Select | 116           | Lets you use terminal FM to monitor U1-16 [SFS Output Frequency]. |
| H4-02 | Terminal FM Analog Output Gain   | 100.0%        |   |
| H4-03 | Terminal FM Analog Output Bias   | 0.0%          |   |
| H4-04 | Terminal AM Analog Output Select | 105           | Lets you use the terminal AM to monitor U1-05 [Motor Speed].      |
| H4-05 | Terminal AM Analog Output Gain   | 50.0%         |   |
| H4-06 | Terminal AM Analog Output Bias   | 0.0%          |   |
| H4-07 | Terminal FM Signal Level Select  | 1             | Lets you monitor in a -10 to +10 V range.                         |
| H4-08 | Terminal AM Signal Level Select  | 1             |   |

These settings cause this MFAO configuration. The MFAO common is terminal AC:

- Terminal FM: Outputs the output frequency after SFS in a -10 V to +10 V (-100% to +100%) range.
- Terminal AM: Outputs the motor speed in a -10 V to +10 V (-200% to +200%) range.

Yaskawa recommends that you monitor the output frequency after SFS and the motor speed for delays in response and differences in reference values.

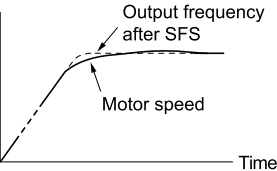
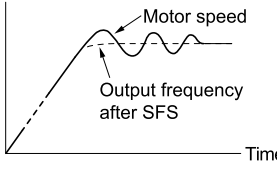
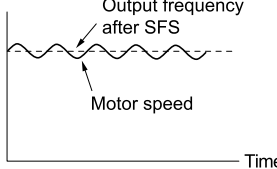
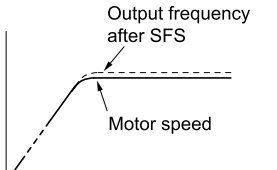
### ■ Adjust ASR Parameters

Use Table 2.33 to adjust ASR. The table shows the parameters for motor 1. When you want to operate motor 2, configure the parameters for motor 2 similarly.

#### Note:

When adjusting the proportional gain and integral time, adjust the proportional gain first.

Table 2.33 ASR Response and Possible Solutions

| Problem   |  | Possible Solutions  |
|---|--|---|
| Speed response is slow.   |  | <ul style="list-style-type: none"> <li>• Increase C5-01/C5-03 [ASR Proportional Gain].</li> <li>• Decrease C5-02/C5-04 [ASR Integral Time].</li> </ul>  |
| Overshoot or undershoot occurs at the end of acceleration or deceleration.  |  | <ul style="list-style-type: none"> <li>• Decrease C5-01/C5-03.</li> <li>• Increase C5-02/C5-04.</li> </ul>  |
| Vibration and oscillation occur at constant speed.  |  | <ul style="list-style-type: none"> <li>• Decrease C5-01/C5-03.</li> <li>• Increase C5-02/C5-04.</li> <li>• Increase C5-06 [ASR Delay Time].</li> </ul>  |
| Speed accuracy is unsatisfactory when you operate a motor that has a large quantity of rated slip in Closed Loop V/f Control. |  | <ul style="list-style-type: none"> <li>• Check the pulse number set to F1-01 [Encoder 1 Pulse Count (PPR)] and the gear ratio set to F1-12 [Encoder 1 Gear Teeth 1] and F1-13 [Encoder 1 Gear Teeth 2].</li> <li>• Make sure that you correctly set the pulse signal from the encoder.</li> <li>• Check U6-04 [ASR Output] to make sure that the ASR operates at its output limit set to C5-05 [ASR Limit]. If the ASR is at the output limit, increase C5-05.</li> </ul> |

## 2.4 C: Tuning

| Problem   |   | Possible Solutions   |
|---|---|--|
| If C5-12 = 1 or C5-32 = 1 [Enabled] in Closed Loop V/f Control, over/undershoot occurs when you change speeds.                                  | - | <ul style="list-style-type: none"> <li>Decrease C5-01/C5-03.</li> <li>Increase C5-02/C5-04.</li> <li>Decrease the value set to C5-05.</li> </ul>   |
| <p>Oscillation at low speed and response is too slow at high speed.</p> <p>Oscillation at high speed and response is too slow at low speed.</p> | - | <ul style="list-style-type: none"> <li>Closed Loop V/f Control Mode:<br/>Use C5-03 and C5-04 at maximum speed and C5-01 and C5-02 at minimum speed to set different ASR settings.</li> <li>Closed Loop Vector Control, PM Advanced Open Loop Vector Control, and PM Closed Loop Vector Control:<br/>Use C5-01 to C5-04 to set the best ASR settings for high and low speed. Use C5-07 [ASR Gain Switchover Frequency] to switch the ASR proportional gain and ASR integral time as specified by the output frequency.</li> </ul> |

### ■ C5-01: ASR Proportional Gain 1

| No. (Hex.)             | Name                    | Description   | Default (Range)                        |
|------------------------|-------------------------|---|--|
| C5-01<br>(021B)<br>RUN | ASR Proportional Gain 1 | <div style="display: flex; justify-content: space-between; font-size: 0.8em;"> <span>V/f</span> <span>CL-V/f</span> <span>OLV</span> <span>CLV</span> <span>AOLV</span> <span>OLV/PM</span> <span>AOLV/PM</span> <span>CLV/PM</span> <span>EZOLV</span> </div> <p>Sets the gain to adjust ASR response.</p> | Determined by A1-02<br>(0.00 - 300.00) |

A higher gain provides a higher speed response. Usually, the gain increases with larger loads. Too much gain will cause vibration.

**Note:**

- The drive usually sets Motor 1 ASR with C5-01 and C5-02 [ASR Integral Time 1]. You can switch between C5-01 and C5-03 [ASR Proportional Gain 2 (P)] by setting H1-xx = 77 [MFDI Function Select = ASR Gain Switch]. You can also use C5-01 and C5-02 as alternatives to C5-03 and C5-04, respectively, when the speed is less than or equal to the frequency set in C5-07 [ASR Gain Switchover Frequency].
- The drive automatically adjusts C5-01 in ASR Tuning.

### ■ C5-02: ASR Integral Time 1

| No. (Hex.)             | Name                | Description   | Default (Range)                           |
|------------------------|---------------------|---|---|
| C5-02<br>(021C)<br>RUN | ASR Integral Time 1 | <div style="display: flex; justify-content: space-between; font-size: 0.8em;"> <span>V/f</span> <span>CL-V/f</span> <span>OLV</span> <span>CLV</span> <span>AOLV</span> <span>OLV/PM</span> <span>AOLV/PM</span> <span>CLV/PM</span> <span>EZOLV</span> </div> <p>Sets the ASR integral time.</p> | Determined by A1-02<br>(0.000 - 60.000 s) |

Increasing the integral time decreases the responsiveness. An integral time that is too short can cause oscillation.

### ■ C5-03: ASR Proportional Gain 2

| No. (Hex.)             | Name                    | Description   | Default (Range)                        |
|------------------------|-------------------------|---|--|
| C5-03<br>(021D)<br>RUN | ASR Proportional Gain 2 | <div style="display: flex; justify-content: space-between; font-size: 0.8em;"> <span>V/f</span> <span>CL-V/f</span> <span>OLV</span> <span>CLV</span> <span>AOLV</span> <span>OLV/PM</span> <span>AOLV/PM</span> <span>CLV/PM</span> <span>EZOLV</span> </div> <p>Sets the gain to adjust ASR response.</p> | Determined by A1-02<br>(0.00 - 300.00) |

A higher gain provides a higher speed response. Usually, the gain increases with larger loads. Too much gain will cause vibration.

### ■ C5-04: ASR Integral Time 2

| No. (Hex.)             | Name                | Description   | Default (Range)                           |
|------------------------|---------------------|---|---|
| C5-04<br>(021E)<br>RUN | ASR Integral Time 2 | <div style="display: flex; justify-content: space-between; font-size: 0.8em;"> <span>V/f</span> <span>CL-V/f</span> <span>OLV</span> <span>CLV</span> <span>AOLV</span> <span>OLV/PM</span> <span>AOLV/PM</span> <span>CLV/PM</span> <span>EZOLV</span> </div> <p>Sets the ASR integral time.</p> | Determined by A1-02<br>(0.000 - 60.000 s) |

Increasing the integral time decreases the responsiveness. An integral time that is too short can cause oscillation.

### ■ C5-05: ASR Limit

| No. (Hex.)      | Name      | Description   | Default (Range)       |
|-----------------|-----------|---|-----------------------|
| C5-05<br>(021F) | ASR Limit | V/f <input checked="" type="checkbox"/> CL-V/f <input type="checkbox"/> OLV <input type="checkbox"/> CLV <input type="checkbox"/> AOLV <input type="checkbox"/> OLV/PM <input type="checkbox"/> AOLV/PM <input type="checkbox"/> CLV/PM <input type="checkbox"/> EZOLV<br>Set the ASR output limit as a percentage of E1-04 [Maximum Output Frequency]. | 5.0%<br>(0.0 - 20.0%) |

If the motor rated slip is high, it is necessary to increase the setting to provide correct motor speed control. Use U6-04 [ASR Output] to make sure that ASR is operating at the limit set in this parameter. When ASR is operating at the limit, correctly set the PG signal and these parameters before you make changes to C5-05.

- F1-01 [Encoder 1 Pulse Count (PPR)]
- F1-12 [Encoder 1 Gear Teeth 1]
- F1-13 [Encoder 1 Gear Teeth 2]

### ■ C5-06: ASR Delay Time

| No. (Hex.)      | Name           | Description  | Default (Range)                          |
|-----------------|----------------|--|--|
| C5-06<br>(0220) | ASR Delay Time | V/f <input type="checkbox"/> CL-V/f <input type="checkbox"/> OLV <input type="checkbox"/> <input checked="" type="checkbox"/> CLV <input type="checkbox"/> AOLV <input type="checkbox"/> OLV/PM <input type="checkbox"/> AOLV/PM <input type="checkbox"/> CLV/PM <input type="checkbox"/> EZOLV<br>Sets the filter time constant of the torque reference output from the speed loop. Usually it is not necessary to change this setting. | Determined by A1-02<br>(0.000 - 0.500 s) |

If you have a load with low rigidity or if oscillation is a problem, decrease C5-01 in units of 2 or decrease C5-06 in units of 0.001.

### ■ C5-07: ASR Gain Switchover Frequency

| No. (Hex.)      | Name                          | Description   | Default (Range)                              |
|-----------------|-------------------------------|---|--|
| C5-07<br>(0221) | ASR Gain Switchover Frequency | V/f <input type="checkbox"/> CL-V/f <input type="checkbox"/> OLV <input type="checkbox"/> <input checked="" type="checkbox"/> CLV <input type="checkbox"/> AOLV <input type="checkbox"/> OLV/PM <input type="checkbox"/> AOLV/PM <input type="checkbox"/> CLV/PM <input type="checkbox"/> EZOLV<br>Sets the frequency where the drive will switch between these parameters:<br>C5-01 and C5-03 [ASR Proportional Gain 1/2]<br>C5-02 and C5-04 [ASR Integral Time 1/2] | Determined by A1-02<br>(Determined by A1-02) |

Switching the proportional gain and integral time in the low or high speed range can help operation become stable. A good switching point is 80% of the frequency where oscillation occurs or at 80% of the maximum output frequency.

**Note:**

An MFDI set for H1-xx = 77 [MFDI Function Select = ASR Gain (C5-03) Select] will have priority over the ASR gain switching frequency.

### ■ C5-08: ASR Integral Limit

| No. (Hex.)      | Name               | Description  | Default (Range)    |
|-----------------|--------------------|--|--------------------|
| C5-08<br>(0222) | ASR Integral Limit | V/f <input type="checkbox"/> CL-V/f <input type="checkbox"/> OLV <input type="checkbox"/> <input checked="" type="checkbox"/> CLV <input type="checkbox"/> AOLV <input type="checkbox"/> OLV/PM <input type="checkbox"/> AOLV/PM <input type="checkbox"/> CLV/PM <input type="checkbox"/> EZOLV<br>Set the upper limit of the ASR integral amount as a percentage of the rated load. | 400%<br>(0 - 400%) |

### ■ C5-12: Integral Operation @ Accel/Decel

| No. (Hex.)      | Name                             | Description  | Default (Range) |
|-----------------|----------------------------------|--|-----------------|
| C5-12<br>(0386) | Integral Operation @ Accel/Decel | V/f <input type="checkbox"/> <input checked="" type="checkbox"/> CL-V/f <input type="checkbox"/> OLV <input type="checkbox"/> CLV <input type="checkbox"/> AOLV <input type="checkbox"/> OLV/PM <input type="checkbox"/> AOLV/PM <input type="checkbox"/> CLV/PM <input type="checkbox"/> EZOLV<br>Sets ASR integral operation during acceleration and deceleration. | 0<br>(0, 1)     |

Set this parameter to 1 if you want the motor speed to be as close to the frequency reference as possible even during acceleration or deceleration.

**Note:**

If you enable integral control, an overshoot or undershoot may occur upon completion of acceleration or deceleration. If there are problems with overshooting and undershooting, set this parameter to 0.

#### 0 : No

Integral operation is always enabled during constant speed. Integral operation is not enabled during acceleration or deceleration.

## 2.4 C: Tuning

### 1 : Yes

Integral operation is always enabled.

#### ■ C5-17: Motor Inertia

| No. (Hex.)                | Name          | Description  | Default (Range)  |
|---------------------------|---------------|--|--|
| C5-17<br>(0276)<br>Expert | Motor Inertia | <div style="display: flex; justify-content: space-between; font-size: 8px; font-weight: normal;"> <span>V/f</span> <span>CL-V/f</span> <span>OLV</span> <span style="background-color: #333; color: white; padding: 2px;">CLV</span> <span>AOLV</span> <span>OLV/PM</span> <span>AOLV/PM</span> <span style="background-color: #333; color: white; padding: 2px;">CLV/PM</span> <span>EZOLV</span> </div> <p>Sets the motor inertia.</p> | Determined by o2-04, C6-01, and E5-01<br>(0.0001 - 600.00 kgm <sup>2</sup> ) |

**Note:**

The default settings and the display units for setting ranges differ depending on the drive model.

- 0.0001 kgm<sup>2</sup> units (setting range: 0.0001 kgm<sup>2</sup> to 6.0000 kgm<sup>2</sup>): 2004 to 2021, 4002 to 4012
- 0.001 kgm<sup>2</sup> units (setting range: 0.001 kgm<sup>2</sup> to 60.000 kgm<sup>2</sup>): 2030 to 2211, 4018 to 4103
- 0.01 kgm<sup>2</sup> units (setting range: 0.01 kgm<sup>2</sup> to 600.00 kgm<sup>2</sup>): 2257 to 2415, 4140 to 4720

When  $A1-02 = 3$  or  $7$  [*Control Method Selection = CLV or CLV/PM*], the drive automatically sets C5-17 to the value of [Motor Inertia] when you do Inertia Tuning or ASR Tuning.

#### ■ C5-18: Load Inertia Ratio

| No. (Hex.)                | Name               | Description   | Default (Range)       |
|---------------------------|--------------------|---|-----------------------|
| C5-18<br>(0277)<br>Expert | Load Inertia Ratio | <div style="display: flex; justify-content: space-between; font-size: 8px; font-weight: normal;"> <span>V/f</span> <span>CL-V/f</span> <span>OLV</span> <span style="background-color: #333; color: white; padding: 2px;">CLV</span> <span>AOLV</span> <span>OLV/PM</span> <span>AOLV/PM</span> <span style="background-color: #333; color: white; padding: 2px;">CLV/PM</span> <span>EZOLV</span> </div> <p>Sets the load inertia ratio for the motor inertia.</p> | 1.0<br>(0.0 - 6000.0) |

When  $A1-02 = 3$  or  $7$  [*Control Method Selection = CLV or CLV/PM*], the drive automatically sets C5-18 to the load inertia ratio when you do Inertia Tuning or ASR Tuning.

#### ■ C5-21: Motor 2 ASR Proportional Gain 1

| No. (Hex.)             | Name                            | Description  | Default (Range)                        |
|------------------------|---------------------------------|--|--|
| C5-21<br>(0356)<br>RUN | Motor 2 ASR Proportional Gain 1 | <div style="display: flex; justify-content: space-between; font-size: 8px; font-weight: normal;"> <span>V/f</span> <span style="background-color: #333; color: white; padding: 2px;">CL-V/f</span> <span>OLV</span> <span style="background-color: #333; color: white; padding: 2px;">CLV</span> <span>AOLV</span> <span>OLV/PM</span> <span>AOLV/PM</span> <span style="background-color: #333; color: white; padding: 2px;">CLV/PM</span> <span>EZOLV</span> </div> <p>Sets the gain to adjust ASR response for motor 2.</p> | Determined by E3-01<br>(0.00 - 300.00) |

A higher gain provides a higher speed response. Usually, the gain increases with larger loads. Too much gain will cause vibration.

**Note:**

- The drive usually sets Motor 2 ASR with C5-21 and C5-22 [*Motor 2 ASR Integral Time 1 (I)*]. You can also use C5-23 [*Motor 2 ASR Proportional Gain 2 (P)*] instead of C5-21 when the speed is less than or equal to the frequency set in C5-27 [*Motor 2 ASR Gain Switchover Freq.*]. You can switch between C5-21 and C5-23 by setting  $H1-xx = 77$  [*MFDI Function Select = ASR Gain Switch*].
- The drive automatically adjusts C5-21 in ASR Tuning.

#### ■ C5-22: Motor 2 ASR Integral Time 1

| No. (Hex.)             | Name                        | Description  | Default (Range)                           |
|------------------------|-----------------------------|--|---|
| C5-22<br>(0357)<br>RUN | Motor 2 ASR Integral Time 1 | <div style="display: flex; justify-content: space-between; font-size: 8px; font-weight: normal;"> <span>V/f</span> <span style="background-color: #333; color: white; padding: 2px;">CL-V/f</span> <span>OLV</span> <span style="background-color: #333; color: white; padding: 2px;">CLV</span> <span>AOLV</span> <span>OLV/PM</span> <span>AOLV/PM</span> <span style="background-color: #333; color: white; padding: 2px;">CLV/PM</span> <span>EZOLV</span> </div> <p>Sets the ASR integral time for motor 2.</p> | Determined by E3-01<br>(0.000 - 60.000 s) |

Increasing the integral time decreases the responsiveness. An integral time that is too short can cause oscillation.

**Note:**

The drive usually sets Motor 2 ASR with C5-21 [*Motor 2 ASR Proportional Gain 1 (P)*] and C5-22. You can also use C5-24 [*Motor 2 ASR Integral Time 2 (I)*] instead of C5-22 when the speed is less than or equal to the frequency set in C5-27 [*Motor 2 ASR Gain Switchover Freq.*].



### ■ C5-23: Motor 2 ASR Proportional Gain 2

| No. (Hex.)             | Name                            | Description   | Default (Range)                        |
|------------------------|---------------------------------|---|--|
| C5-23<br>(0358)<br>RUN | Motor 2 ASR Proportional Gain 2 | V/f <input type="checkbox"/> CL-V/f <input checked="" type="checkbox"/> OLV <input type="checkbox"/> CLV <input checked="" type="checkbox"/> AOLV <input type="checkbox"/> OLV/PM <input type="checkbox"/> AOLV/PM <input type="checkbox"/> CLV/PM <input type="checkbox"/> EZOLV <input type="checkbox"/><br>Sets the gain to adjust ASR response for motor 2. | Determined by E3-01<br>(0.00 - 300.00) |

A higher gain provides a higher speed response. Usually, the gain increases with larger loads. Too much gain causes vibration.

### ■ C5-24: Motor 2 ASR Integral Time 2

| No. (Hex.)             | Name                        | Description   | Default (Range)                           |
|------------------------|-----------------------------|---|---|
| C5-24<br>(0359)<br>RUN | Motor 2 ASR Integral Time 2 | V/f <input type="checkbox"/> CL-V/f <input checked="" type="checkbox"/> OLV <input type="checkbox"/> CLV <input checked="" type="checkbox"/> AOLV <input type="checkbox"/> OLV/PM <input type="checkbox"/> AOLV/PM <input type="checkbox"/> CLV/PM <input type="checkbox"/> EZOLV <input type="checkbox"/><br>Sets the ASR integral time for motor 2. | Determined by E3-01<br>(0.000 - 60.000 s) |

Increasing the integral time decreases the responsiveness. An integral time that is too short can cause oscillation.

**Note:**

The drive usually sets Motor 2 ASR with C5-21 [Motor 2 ASR Proportional Gain 1 (P)] and C5-22 [Motor 2 ASR Integral Time 1 (I)]. You can also use C5-24 [Motor 2 ASR Integral Time 2 (I)] instead of C5-22 when the speed is less than or equal to the frequency set in C5-27 [Motor 2 ASR Gain Switchover Freq].

### ■ C5-25: Motor 2 ASR Limit

| No. (Hex.)      | Name              | Description   | Default (Range)       |
|-----------------|-------------------|---|-----------------------|
| C5-25<br>(035A) | Motor 2 ASR Limit | V/f <input type="checkbox"/> CL-V/f <input checked="" type="checkbox"/> OLV <input type="checkbox"/> CLV <input checked="" type="checkbox"/> AOLV <input type="checkbox"/> OLV/PM <input type="checkbox"/> AOLV/PM <input type="checkbox"/> CLV/PM <input type="checkbox"/> EZOLV <input type="checkbox"/><br>Set the motor 2 ASR output limit as a percentage of E1-04 [Maximum Output Frequency]. | 5.0%<br>(0.0 - 20.0%) |

If the motor rated slip is high, it is necessary to increase the setting to provide correct motor speed control. Use U6-04 [ASR Output] to make sure that ASR is operating at the limit set in this parameter. When ASR is operating at the limit, correctly set the PG signal and these parameters before you make changes to C5-25.

- F1-31 [Encoder 2 Pulse Count (PPR)]
- F1-33 [Encoder 2 Gear Teeth 1]
- F1-34 [Encoder 2 Gear Teeth 2]

### ■ C5-26: Motor 2 ASR Delay Time

| No. (Hex.)      | Name                   | Description   | Default (Range)                          |
|-----------------|------------------------|---|--|
| C5-26<br>(035B) | Motor 2 ASR Delay Time | V/f <input type="checkbox"/> CL-V/f <input type="checkbox"/> OLV <input checked="" type="checkbox"/> CLV <input checked="" type="checkbox"/> AOLV <input type="checkbox"/> OLV/PM <input type="checkbox"/> AOLV/PM <input type="checkbox"/> CLV/PM <input type="checkbox"/> EZOLV <input type="checkbox"/><br>Sets the motor 2 filter time constant of the torque reference output from the speed loop. Usually it is not necessary to change this setting. | Determined by E3-01<br>(0.000 - 0.500 s) |

If you have a load with low rigidity or if oscillation is a problem, decrease C5-21 in units of 2 or decrease C5-26 in units of 0.001.

### ■ C5-27: Motor 2 ASR Gain Switchover Freq

| No. (Hex.)      | Name                             | Description  | Default (Range)      |
|-----------------|----------------------------------|--|----------------------|
| C5-27<br>(035C) | Motor 2 ASR Gain Switchover Freq | V/f <input type="checkbox"/> CL-V/f <input type="checkbox"/> OLV <input checked="" type="checkbox"/> CLV <input checked="" type="checkbox"/> AOLV <input type="checkbox"/> OLV/PM <input type="checkbox"/> AOLV/PM <input type="checkbox"/> CLV/PM <input type="checkbox"/> EZOLV <input type="checkbox"/><br>Sets the frequency where the drive will switch between these parameters:<br>C5-21 and C5-23 [Motor 2 ASR Proportional Gain 1 (P)/2 (P)]<br>C5-22 and C5-24 [Motor 2 ASR Integral Time 1 (I)/2 (I)] | 0.0<br>(0.0 - 400.0) |

Switching the proportional gain and integral time in the low or high speed range can help operation become stable. A good switching point is 80% of the frequency where oscillation occurs or at 80% of the maximum output frequency.

**Note:**

An MFDI set for H1-xx = 77 [MFDI Function Select = ASR Gain (C5-03) Select] will have priority over the ASR gain switching frequency.

## 2.4 C: Tuning

### ■ C5-28: Motor 2 ASR Integral Limit

| No. (Hex.)      | Name                       | Description  | Default (Range)    |
|-----------------|----------------------------|--|--------------------|
| C5-28<br>(035D) | Motor 2 ASR Integral Limit | <input type="checkbox"/> V/f <input type="checkbox"/> CL-V/f <input type="checkbox"/> OLV <input checked="" type="checkbox"/> CLV <input type="checkbox"/> AOLV <input type="checkbox"/> OLV/PM <input type="checkbox"/> AOLV/PM <input type="checkbox"/> CLV/PM <input type="checkbox"/> EZOLV<br>Set the upper limit of the motor 2 ASR integral amount as a percentage of the rated load. | 400%<br>(0 - 400%) |

### ■ C5-29: Speed Control Response

| No. (Hex.)                | Name                   | Description  | Default (Range) |
|---------------------------|------------------------|--|-----------------|
| C5-29<br>(0B18)<br>Expert | Speed Control Response | <input checked="" type="checkbox"/> V/f <input type="checkbox"/> CL-V/f <input type="checkbox"/> OLV <input type="checkbox"/> CLV <input type="checkbox"/> AOLV <input type="checkbox"/> OLV/PM <input type="checkbox"/> AOLV/PM <input type="checkbox"/> CLV/PM <input type="checkbox"/> EZOLV<br>Sets the level of speed control responsiveness. Usually it is not necessary to change this setting. | 0<br>(0, 1)     |

If a high level of speed control responsiveness is necessary, set  $C5-29 = 1$ , then adjust the speed control (ASR) parameter.

**0 : Standard**

**1 : High Performance 1**

### ■ C5-32: Motor 2 Integral Oper at Acc/Dec

| No. (Hex.)      | Name                             | Description  | Default (Range) |
|-----------------|----------------------------------|--|-----------------|
| C5-32<br>(0361) | Motor 2 Integral Oper at Acc/Dec | <input type="checkbox"/> V/f <input checked="" type="checkbox"/> CL-V/f <input type="checkbox"/> OLV <input type="checkbox"/> CLV <input type="checkbox"/> AOLV <input type="checkbox"/> OLV/PM <input type="checkbox"/> AOLV/PM <input type="checkbox"/> CLV/PM <input type="checkbox"/> EZOLV<br>Sets ASR integral operation during acceleration and deceleration for motor 2. | 0<br>(0, 1)     |

Set this parameter to  $1$  if you want the motor speed to be as close to the frequency reference as possible even during acceleration or deceleration.

**Note:**

If you enable integral control, an overshoot or undershoot may occur upon completion of acceleration or deceleration. If there are problems with overshooting and undershooting, set this parameter to  $0$ .

**0 : No**

Integral operation is not enabled during acceleration or deceleration. Integral operation is always enabled during constant speed.

**1 : Yes**

Integral operation is always enabled.

### ■ C5-37: Motor 2 Inertia

| No. (Hex.)                | Name            | Description  | Default (Range)   |
|---------------------------|-----------------|--|---|
| C5-37<br>(0278)<br>Expert | Motor 2 Inertia | <input type="checkbox"/> V/f <input type="checkbox"/> CL-V/f <input type="checkbox"/> OLV <input checked="" type="checkbox"/> CLV <input type="checkbox"/> AOLV <input type="checkbox"/> OLV/PM <input type="checkbox"/> AOLV/PM <input type="checkbox"/> CLV/PM <input type="checkbox"/> EZOLV<br>Sets the motor inertia for motor 2. | Determined by o2-04, C6-01<br>(0.0001 - 600.00 kgm <sup>2</sup> ) |

**Note:**

The default settings and the display units for setting ranges differ depending on the drive model.

- 0.0001 kgm<sup>2</sup> units (setting range: 0.0001 kgm<sup>2</sup> to 6.0000 kgm<sup>2</sup>): 2004 to 2021, 4002 to 4012
- 0.001 kgm<sup>2</sup> units (setting range: 0.001 kgm<sup>2</sup> to 60.000 kgm<sup>2</sup>): 2030 to 2211, 4018 to 4103
- 0.01 kgm<sup>2</sup> units (setting range: 0.01 kgm<sup>2</sup> to 600.00 kgm<sup>2</sup>): 2257 to 2415, 4140 to 4720

The drive automatically sets  $C5-37$  to the value of [Motor Inertia] when you do Inertia Tuning or ASR Tuning.

### ■ C5-38: Motor 2 Load Inertia Ratio

| No. (Hex.)                | Name                       | Description  | Default (Range)       |
|---------------------------|----------------------------|--|-----------------------|
| C5-38<br>(0279)<br>Expert | Motor 2 Load Inertia Ratio | V/f CL-V/f OLV <b>CLV</b> AOLV OLV/PM AOLV/PM CLV/PM EZOLV<br>Sets the load inertia ratio for the motor 2 inertia. | 1.0<br>(0.0 - 6000.0) |

The drive automatically sets C5-38 to the value of [Load Inertia Ratio] when you do Inertia Tuning or ASR Tuning.

### ■ C5-39: ASR Primary Delay Time Const 2

| No. (Hex.)      | Name                           | Description   | Default (Range)              |
|-----------------|--------------------------------|---|------------------------------|
| C5-39<br>(030D) | ASR Primary Delay Time Const 2 | V/f CL-V/f OLV CLV AOLV OLV/PM <b>AOLV/PM</b> <b>CLV/PM</b> EZOLV<br>Sets the filter time constant used when the torque reference is output from ASR. Usually it is not necessary to change this parameter. | 0.000 s<br>(0.000 - 0.500 s) |

If you have a load with low rigidity or if oscillation is a problem, increase this setting in 0.01 unit increments.

### ■ C5-50: Notch Filter Frequency

| No. (Hex.)                | Name                   | Description  | Default (Range)             |
|---------------------------|------------------------|--|-----------------------------|
| C5-50<br>(0B14)<br>Expert | Notch Filter Frequency | V/f CL-V/f OLV <b>CLV</b> AOLV OLV/PM AOLV/PM <b>CLV/PM</b> EZOLV<br>Sets the machine resonance frequency. | 0 Hz<br>(0, or 2 to 100 Hz) |

Machine resonance can cause high-frequency noise and vibration during operation. A notch filter can help prevent the noise and vibration. Notch filters set the resonant frequency of the machine to remove specific vibrational frequency components caused by machine resonance.

**Note:**

- Correctly set the value for the notch filter frequency. If the frequency value is too low in regards to the speed loop response frequency, it could have an adverse effect on the speed control functionality. Set the frequency to be a minimum of 4 times the speed loop response frequency.
- Set C5-50 = 0 [0 Hz] to disable the notch filter.

### ■ C5-51: Notch Filter Bandwidth

| No. (Hex.)                | Name                   | Description  | Default (Range)    |
|---------------------------|------------------------|--|--------------------|
| C5-51<br>(0B15)<br>Expert | Notch Filter Bandwidth | V/f CL-V/f OLV <b>CLV</b> AOLV OLV/PM AOLV/PM <b>CLV/PM</b> EZOLV<br>Sets the notch width of the notch filter. | 1.0<br>(0.5 - 5.0) |

**Note:**

Set C5-50 = 0 [Notch Filter Frequency = 0 Hz] to disable the notch filter.

## ◆ C6: Duty & Carrier Frequency

C6 parameters are used to set the selection of drive duty rating, selection of carrier frequency, and upper and lower limits of carrier frequencies.

### ■ C6-01: Normal / Heavy Duty Selection

| No. (Hex.)      | Name                          | Description   | Default (Range) |
|-----------------|-------------------------------|---|-----------------|
| C6-01<br>(0223) | Normal / Heavy Duty Selection | V/f <b>CL-V/f</b> OLV <b>CLV</b> AOLV OLV/PM AOLV/PM <b>CLV/PM</b> EZOLV<br>Sets the drive duty rating. | 1<br>(0, 1)     |

#### 0 : Heavy Duty Rating

The overload tolerance is 150% of the rated output current for 60 seconds.

#### 1 : Normal Duty Rating

## 2.4 C: Tuning

The overload tolerance is 110% of the rated output current for 60 seconds.

There are two types of load ratings for this product depending on the load characteristics of the application: Heavy Duty Rating (HD) and Normal Duty Rating (ND).

The drive rated output current, overload tolerance, and acceleration stall prevention level change when the duty rating changes. Set the drive to agree with the duty rating of the selected drive capacity. In HD, the tolerance is 150% overload for 60 seconds. In ND, the tolerance is 110% overload for 60 seconds. The rated output current for ND drives is higher than the rated output current for HD drives. Refer to “Model Specifications (200 V Class)” and “Model Specifications (400 V Class)” for more information about rated output current.

**Note:**

This product has two more load characteristic types: HD2 and ND2. When the value of *E1-01 [Input AC Supply Voltage]* is 460 V or more, the load characteristic level automatically changes from HD1 to HD2 or from ND1 to ND2.

**Table 2.34 Differences between Heavy Duty Rating and Normal Duty Rating**

| Item                             | Heavy Duty Rating 1 (HD1)   | Heavy Duty Rating 2 (HD2) | Normal Duty Rating 1 (ND1)   | Normal Duty Rating 2 (ND2) |
|----------------------------------|---|---------------------------|--|----------------------------|
| E1-01 Setting                    | 200 V ≤ E1-01 ≤ 240 V<br>380 V ≤ E1-01 < 460 V  | 460 V ≤ E1-01 < 480 V     | 200 V ≤ E1-01 ≤ 240 V<br>380 V ≤ E1-01 < 460 V   | 460 V ≤ E1-01 < 480 V      |
| C6-01 Setting                    | 0   |                           | 1  |                            |
| Load Characteristics             |   |                           |  |                            |
| Application                      | A high overload tolerance is necessary during start up, acceleration, deceleration, and equivalent conditions. <ul style="list-style-type: none"> <li>• Extruder</li> <li>• Conveyor</li> <li>• Constant torque or high overload capacity are necessary.</li> </ul> |                           | Overload tolerance is not necessary. <ul style="list-style-type: none"> <li>• Fan</li> <li>• Pump</li> <li>• Blower</li> </ul> |                            |
| Overload Tolerance               | 150% - 60 seconds   |                           | 110% - 60 seconds  |                            |
| Stall Prevent Level during Accel | 150%  |                           | 110%   |                            |
| Stall Prevent Level during Run   | 150%  |                           | 110%   |                            |
| Carrier Frequency                | 2 kHz   |                           | 2 kHz Swing-PWM  |                            |

**Note:**

- Set the stall prevention level during acceleration with *L3-02* and the stall prevention level during run with *L3-06*.
- Changing *C6-01* also changes the maximum capacity of applicable drive motors. The drive automatically changes the setting values *E2-xx* and *E4-xx* to applicable values. The drive also automatically changes these parameters that depend on motor output:
  - b8-04 [Energy Saving Coefficient Value]
  - C5-17 [Motor Inertia]
  - C5-37 [Motor 2 Inertia]
  - L2-03 [Minimum Baseblock Time]
  - L3-24 [Motor Accel Time @ Rated Torque]
  - n5-02 [Motor Inertia Acceleration Time]

### ■ C6-02: Carrier Frequency Selection

| No. (Hex.)   | Name                        | Description   | Default (Range)  |
|--------------|-----------------------------|---|--|
| C6-02 (0224) | Carrier Frequency Selection | <span style="background-color: #cccccc; padding: 2px;">V/f</span> <span style="background-color: #cccccc; padding: 2px;">CL-V/f</span> <span style="background-color: #cccccc; padding: 2px;">OLV</span> <span style="background-color: #cccccc; padding: 2px;">CLV</span> <span style="background-color: #cccccc; padding: 2px;">AOLV</span> <span style="background-color: #cccccc; padding: 2px;">OLV/PM</span> <span style="background-color: #cccccc; padding: 2px;">AOLV/PM</span> <span style="background-color: #cccccc; padding: 2px;">CLV/PM</span> <span style="background-color: #cccccc; padding: 2px;">EZOLV</span><br>Sets the carrier frequency for the transistors in the drive. | Determined by A1-02, C6-01, and o2-04<br>(Determined by A1-02) |

Changes to the switching frequency will decrease audible noise and decrease leakage current.

**Note:**

Increasing the carrier frequency to more than the default setting will automatically decrease the drive current rating.

- 1 : 2.0 kHz**
- 2 : 5.0 kHz (4.0 kHz AOLV/PM)**
- 3 : 8.0 kHz (6.0 kHz AOLV/PM)**
- 4 : 10.0 kHz (8.0 kHz AOLV/PM)**
- 5 : 12.5 kHz (10.0 kHz AOLV/PM)**
- 6 : 15.0 kHz (12.0 kHz AOLV/PM)**
- 7 : Swing PWM4 (Audible Sound 1)**
- 8 : Swing PWM4 (Audible Sound 2)**
- 9 : Swing PWM4 (Audible Sound 3)**
- A : Swing PWM4 (Audible Sound 4)**
- F : User Defined (C6-03 to C6-05)**

Use *C6-03 to C6-05* to set detailed setting values.

**Note:**

- The carrier frequency for Swing PWM 1 is equivalent to 2.0 kHz. Swing PWM applies a special PWM pattern to decrease the audible noise.
- The setting range changes when the *A1-02 [Control Method Selection]* value changes:
  - 3, 5, 7, 8 [*CLV, OLV/PM, CLV/PM, EZOLV*]: You cannot set to 7 to A.
  - 4 [*AOLV*]: You cannot set to 6, 7 to A, or F.
  - 6 [*AOLV/PM*]: You cannot set to 7 to A or F.

**Table 2.35 Guidelines for Carrier Frequency Parameter Setup**

| Symptom   | Remedy  |
|---|---|
| Speed and torque are not stable at low speed.   | Decrease the carrier frequency.   |
| Speed and torque are not stable at low speed.   | Decrease the carrier frequency.   |
| Too much leakage current from the drive.        | Decrease the carrier frequency.   |
| Wiring between the drive and motor is too long. | Decrease the carrier frequency.<br><b>Note:</b><br>If the motor cable is too long, it can be necessary to decrease the carrier frequency. Refer to Table 2.36 for the wiring distance and decrease the carrier frequency.   |
| Audible motor noise is too loud.                | Increase the carrier frequency. Use Swing PWM.<br><b>Note:</b><br>The default carrier frequency in ND is Swing PWM 1 ( <i>C6-02</i> = 7), with a 2 kHz base. You can increase the carrier frequency in Normal Duty mode, but this will also decrease the drive rated current. |

**Table 2.36 Wiring Distance**

| Wiring Distance                            | Up to 50 m            | Up to 100 m             | Greater than 100 m |
|--|-----------------------|-------------------------|--------------------|
| <i>C6-02</i> [Carrier Frequency Selection] | 1 to F (up to 15 kHz) | 1 to 2 (up to 5 kHz), 7 | 1 (up to 2 kHz), 7 |

**Note:**

When *A1-02* = 5 or 6 [*Control Method Selection* = *OLV/PM* or *AOLV/PM*], the maximum cable length is 100 m (328 ft).

**■ C6-03: Carrier Frequency Upper Limit**

| No. (Hex.)          | Name                          | Description  | Default (Range)                             |
|---------------------|-------------------------------|--|---|
| <i>C6-03</i> (0225) | Carrier Frequency Upper Limit | <div style="display: flex; gap: 5px;"> <span>V/f</span> <span>CL-V/f</span> <span>OLV</span> <span>CLV</span> <span>AOLV</span> <span>OLV/PM</span> <span>AOLV/PM</span> <span>CLV/PM</span> <span>EZOLV</span> </div> Sets the upper limit of the carrier frequency. Set <i>C6-02</i> = F [ <i>Carrier Frequency Selection</i> = User Defined ( <i>C6-03 to C6-05</i> )] to set this parameter. | Determined by <i>C6-02</i> (1.0 - 15.0 kHz) |

**Setting a Fixed User-Defined Carrier Frequency**

When you cannot use *C6-02* to set a carrier frequency between set selectable values, you can set the value in *C6-03*. The carrier frequency will be fixed to the value set to *C6-03*.

When *A1-02* = 0, 1 [*Control Method Selection* = *V/f, CL-V/f*], set *C6-03* = *C6-04* [*Carrier Frequency Lower Limit*] to fix the carrier frequency.

## 2.4 C: Tuning

### Setting a Variable Carrier Frequency to Agree with the Output Frequency

When  $A1-02 = 0, 1$ , set  $C6-03$ ,  $C6-04$ , and  $C6-05$  [Carrier Freq Proportional Gain] as shown in Figure 2.58 to make the carrier frequency change linearly with the output frequency.

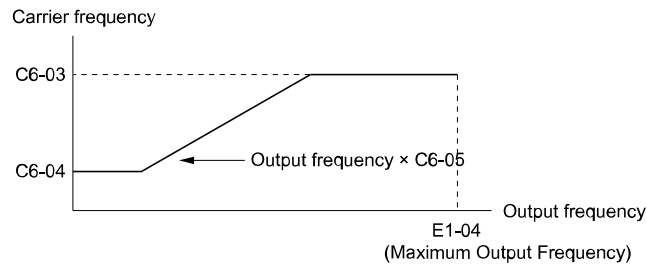


Figure 2.58 Setting a Variable Carrier Frequency to Agree with the Output Frequency

**Note:**

- When  $C6-05 \leq 7$ , the drive disables  $C6-04$ . The carrier frequency is fixed to the value set to  $C6-03$ .
- The drive detects  $oPE11$  [Carrier Frequency Setting Error] when these conditions are correct at the same time:
  - $C6-05 \geq 6$
  - $C6-04 \geq C6-03$

### ■ C6-04: Carrier Frequency Lower Limit

| No. (Hex.)   | Name                          | Description  | Default (Range)                      |
|--------------|-------------------------------|--|--------------------------------------|
| C6-04 (0226) | Carrier Frequency Lower Limit | <input type="checkbox"/> V/f <input checked="" type="checkbox"/> CL-V/f <input type="checkbox"/> OLV <input type="checkbox"/> CLV <input type="checkbox"/> AOLV <input type="checkbox"/> OLV/PM <input type="checkbox"/> AOLV/PM <input type="checkbox"/> CLV/PM <input type="checkbox"/> EZOLV<br>Sets the lower limit of the carrier frequency. Set $C6-02 = F$ [Carrier Frequency Selection = User Defined (C6-03 to C6-05)] to set this parameter. | Determined by C6-02 (1.0 - 15.0 kHz) |

Set  $C6-03$  [Carrier Frequency Upper Limit],  $C6-04$ , and  $C6-05$  [Carrier Freq Proportional Gain] to make the carrier frequency change linearly with the output frequency.

**Note:**

- The drive detects  $oPE11$  [Carrier Frequency Setting Error] when these conditions are correct at the same time:
- $C6-04 \geq C6-03$
  - $C6-05 \geq 6$

### ■ C6-05: Carrier Freq Proportional Gain

| No. (Hex.)   | Name                           | Description   | Default (Range)              |
|--------------|--------------------------------|---|------------------------------|
| C6-05 (0227) | Carrier Freq Proportional Gain | <input type="checkbox"/> V/f <input checked="" type="checkbox"/> CL-V/f <input type="checkbox"/> OLV <input type="checkbox"/> CLV <input type="checkbox"/> AOLV <input type="checkbox"/> OLV/PM <input type="checkbox"/> AOLV/PM <input type="checkbox"/> CLV/PM <input type="checkbox"/> EZOLV<br>Sets the proportional gain for the carrier frequency. Set $C6-02 = F$ [Carrier Frequency Selection = User Defined (C6-03 to C6-05)] to set this parameter. | Determined by C6-02 (0 - 99) |

Set  $C6-03$  [Carrier Frequency Upper Limit],  $C6-04$  [Carrier Frequency Lower Limit], and  $C6-05$  to make the carrier frequency change linearly with the output frequency.

### ■ C6-09: Carrier Freq at Rotational Tune

| No. (Hex.)   | Name                            | Description  | Default (Range) |
|--------------|---------------------------------|--|-----------------|
| C6-09 (022B) | Carrier Freq at Rotational Tune | <input type="checkbox"/> V/f <input type="checkbox"/> CL-V/f <input checked="" type="checkbox"/> OLV <input type="checkbox"/> CLV <input type="checkbox"/> AOLV <input type="checkbox"/> OLV/PM <input type="checkbox"/> AOLV/PM <input type="checkbox"/> CLV/PM <input type="checkbox"/> EZOLV<br>Sets the Auto-Tuning carrier frequency. Usually it is not necessary to change this setting. | 0 (0, 1)        |

When you set  $C6-09 = 0$  for a high-frequency or low-impedance motor,  $oC$  [Overcurrent] may occur. To prevent  $oC$ , set the carrier frequency to a high value and set  $C6-09 = 1$  before performing Auto-Tuning.

The procedure to set the carrier frequency when the  $A1-02$  [Control Method Selection] setting changes.

- When  $A1-02 = 2, 3$  [OLV, CLV], set  $C6-02 = F$  [Carrier Frequency Selection = User Defined] and then increase the value set to  $C6-03$  [Carrier Frequency Upper Limit].
- When  $A1-02 = 4$  to  $7$  [AOLV, OLV/PM, AOLV/PM, or CLV/PM], use  $C6-02$  to increase the carrier frequency.

### 0 : Carrier frequency 5 kHz

**Note:**

If  $A1-02 = 5, 6, 7$  [Control Method Selection = *OLV/PM, AOLV/PM, CLV/PM*], the carrier frequency is 2 kHz.

**1 : use C6-03****Note:**

If  $A1-02 = 5, 6, 7$  [Control Method Selection = *OLV/PM, AOLV/PM, CLV/PM*], the carrier frequency is as specified in C6-02.

## 2.5 d: Softstarter

*d* parameters [References] set the frequency reference input method and dead band range. They also set torque control, field weakening, and field forcing functions.

**WARNING! Sudden Movement Hazard.** Use fast stop circuits to safely and quickly stop the drive. After you wire the fast stop circuits, you must check their operation. Test the operation of the fast stop function before you use the drive. If you do not test the fast stop circuit before you operate the drive, it can cause serious injury or death.

**WARNING! Sudden Movement Hazard.** When you use the drive in a lifting application, you must also install external safety circuitry. The drive does not have protection against accidental load drops in lifting applications. Install electrical and/or mechanical safety circuit mechanisms that are isolated from the drive circuitry. If you do not use external safety circuitry, the drive could drop the load and cause serious injury or death.

### ◆ d1: Frequency Reference

Figure 2.59 shows the frequency reference input method, command source selection method and priority descriptions.

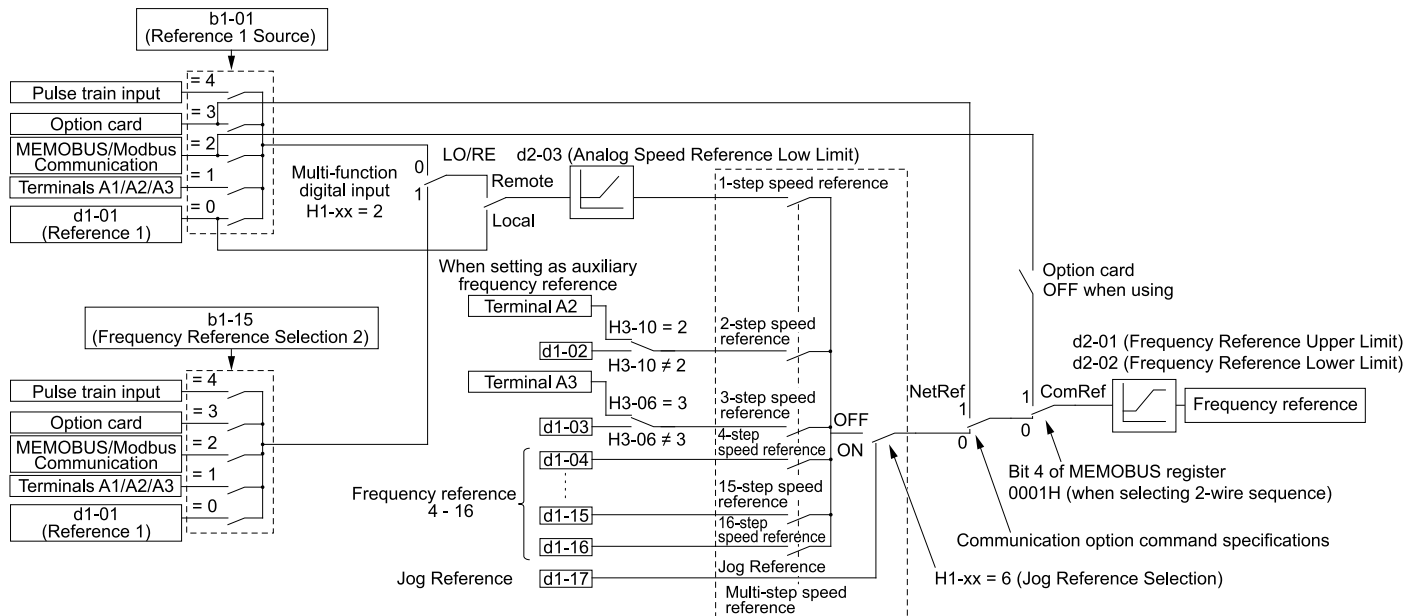


Figure 2.59 Frequency Reference Setting Hierarchy

### ■ Multi-Step Speed Operation

The drive has a multi-step speed operation function that can set many frequency references in advance. Set frequency references in *d1-xx* parameters. You can select the set frequency references with MFDI signals from an external source. Activate and deactivate the digital input to select the frequency reference to change the motor speed in steps. You can use the 16-step frequency reference and one Jog Frequency Reference (JOG command) to switch the speed to the maximum 17-step speeds.

**Note:**

- The Jog Frequency Reference (JOG command) overrides all other frequency references.
- You can use the MFDI to switch the frequency reference when the motor is running. The drive will apply the enabled acceleration and deceleration times.
- The default settings for Multi-Step Speed Reference 1 (master frequency reference) and Multi-Step Speed Reference 2 (auxiliary frequency reference) are the analog frequency reference. Also, voltage command input terminal A1 and current input terminal A2 for Multi-Step Speed Reference 1 (master frequency reference) are added internally by default. The drive uses Multi-Step Speed Reference 1 when the signal is connected to an analog input terminal.

### ■ Setting Procedures for Multi-step Speed Operation

#### Use an Analog Input as Reference 1 and 2

This section gives information about the procedures to set these examples:

- Multi-Step Speed 6 (6 types of frequency references)



- When you set the voltage input of analog inputs from terminals A1 and A3 to -10 V to +10 V

| Procedure | Configuration Parameter           | Task Contents  |
|-----------|-----------------------------------|--|
| 1         | Reference 1                       | 1. Sets $b1-01 = 1$ [Frequency Reference Selection 1 = Analog Input].<br>2. Sets $H3-02 = 0$ [Terminal A1 Function Selection = Frequency Reference].<br>3. Sets $H3-01 = 1$ [Terminal A1 Signal Level Select = -10 to +10V (Bipolar Reference)]. |
| 2         | Reference 2                       | 1. Sets $H3-06 = 2$ [Terminal A3 Function Selection = Auxiliary Frequency Reference 1].<br>2. Set $H3-05 = 1$ [Terminal A3 Signal Level Select = -10 V to +10 V (Lower Limit at -10)].   |
| 3         | Signal type of analog input       | Set DIP switches S1-1 and S1-3 on the control circuit board to the V-side (voltage).<br><b>Note:</b><br>Set this before you energize the drive.  |
| 4         | Reference 3                       | Sets the value of $d1-03$ [Reference 3].   |
| 5         | Reference 4                       | Sets the value of $d1-04$ [Reference 4].   |
| 6         | Reference 5                       | Sets the value of $d1-05$ [Reference 5].   |
| 7         | Jog Reference                     | Sets $d1-17$ [Jog Reference] to the jog speed.   |
| 8         | External digital input (3 inputs) | Set the Multi-Step Speed Reference 1 to 3 [ $H1-xx = 3, 4, 5$ ] to one of the MFDI terminals S1 to S8.   |
| 9         | JOG command                       | Set the Jog Reference Selection [ $H1-xx = 6$ ] to one of the MFDI terminals S1 to S8.   |

### Use the Maximum 17-Step Speed with All Digital Inputs

This section is the procedure to set the 17-step speeds (17 types of frequency references) without an analog input.

| Procedure | Configuration Parameter           | Task Contents  |
|-----------|-----------------------------------|--|
| 1         | Reference 1                       | 1. Set $b1-01 = 0$ [Frequency Reference Selection 1 = Keypad].<br>2. Sets the value of $d1-01$ [Reference 1].                                      |
| 2         | Reference 2                       | 1. Sets $H3-06 = F$ [Terminal A3 Function Selection = Not Used], and disables the analog reference.<br>2. Sets the value of $d1-02$ [Reference 2]. |
| 3         | Reference 3                       | 1. Sets $H3-10 = F$ [Terminal A2 Function Selection = Not Used], and disables the analog reference.<br>2. Sets the value of $d1-03$ [Reference 3]. |
| 4         | Reference 4                       | Sets the value of $d1-04$ [Reference 4].   |
| 5         | Reference 5 to 16                 | Sets the values of $d1-05$ to $d1-16$ [Reference 5 to 16].   |
| 6         | Jog Reference                     | Sets $d1-17$ [Jog Reference] to the jog speed.   |
| 7         | External digital input (4 inputs) | Set Multi-Step Speed Reference 1 to 4 [ $H1-xx = 3, 4, 5, 32$ ] to one of the MFDI terminals S1 to S8.   |
| 8         | JOG command                       | Set the Jog Reference Selection [ $H1-xx = 6$ ] to one of the MFDI terminals S1 to S8.   |

### Multi-step Speed Operation Combinations

Refer to Table 2.37 and Figure 2.60 for information about multi-step speed reference combinations. The selected frequency reference changes when the combination of digital input signals from an external source changes.

**Table 2.37 Multi-step Speed Reference and MFDI Terminal Combinations**

| Related Parameters                             | Multi-Step Speed Reference 1<br>$H1-xx = 3$ | Multi-Step Speed Reference 2<br>$H1-xx = 4$ | Multi-Step Speed Reference 3<br>$H1-xx = 5$ | Multi-Step Speed Reference 4<br>$H1-xx = 32$ | Jog Reference<br>$H1-xx = 6$ |
|--|---|---|---|--|------------------------------|
| Reference 1 (set in $b1-01$ )                  | OFF   | OFF   | OFF   | OFF  | OFF                          |
| Reference 2 ( $d1-02$ or terminals A1, A2, A3) | ON  | OFF   | OFF   | OFF  | OFF                          |
| Reference 3 ( $d1-03$ or terminals A1, A2, A3) | OFF   | ON  | OFF   | OFF  | OFF                          |
| Reference 4 ( $d1-04$ )                        | ON  | ON  | OFF   | OFF  | OFF                          |
| Reference 5 ( $d1-05$ )                        | OFF   | OFF   | ON  | OFF  | OFF                          |
| Reference 6 ( $d1-06$ )                        | ON  | OFF   | ON  | OFF  | OFF                          |
| Reference 7 ( $d1-07$ )                        | OFF   | ON  | ON  | OFF  | OFF                          |
| Reference 8 ( $d1-08$ )                        | ON  | ON  | ON  | OFF  | OFF                          |
| Reference 9 ( $d1-09$ )                        | OFF   | OFF   | OFF   | ON   | OFF                          |

## 2.5 d: Softstarter

| Related Parameters       | Multi-Step Speed Reference 1<br>H1-xx = 3 | Multi-Step Speed Reference 2<br>H1-xx = 4 | Multi-Step Speed Reference 3<br>H1-xx = 5 | Multi-Step Speed Reference 4<br>H1-xx = 32 | Jog Reference<br>H1-xx = 6 |
|--------------------------|---|---|---|--|----------------------------|
| Reference 10 (d1-10)     | ON  | OFF                                       | OFF                                       | ON   | OFF                        |
| Reference 11 (d1-11)     | OFF                                       | ON  | OFF                                       | ON   | OFF                        |
| Reference 12 (d1-12)     | ON  | ON  | OFF                                       | ON   | OFF                        |
| Reference 13 (d1-13)     | OFF                                       | OFF                                       | ON  | ON   | OFF                        |
| Reference 14 (d1-14)     | ON  | OFF                                       | ON  | ON   | OFF                        |
| Reference 15 (d1-15)     | OFF                                       | ON  | ON  | ON   | OFF                        |
| Reference 16 (d1-16)     | ON  | ON  | ON  | ON   | OFF                        |
| Jog Reference (d1-17) *1 | -   | -   | -   | -  | ON                         |

\*1 The Jog Frequency Reference (JOG command) overrides all other frequency references.

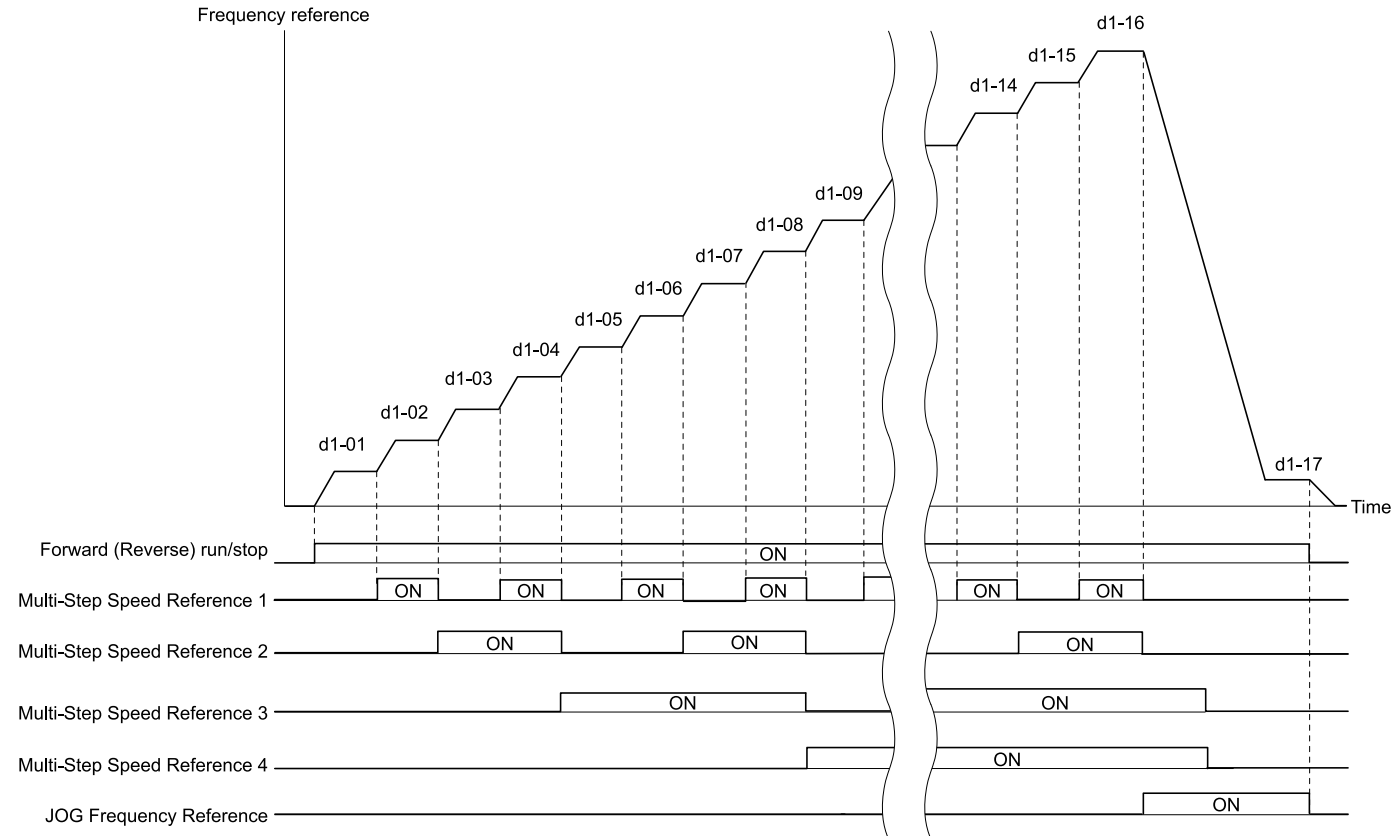


Figure 2.60 Time Chart for Multi-step Speed Reference/JOG Reference










### ■ d1-01: Reference 1

| No. (Hex.)             | Name        | Description   | Default (Range)               |
|------------------------|-------------|---|-------------------------------|
| d1-01<br>(0280)<br>RUN | Reference 1 | <span style="background-color: #cccccc; padding: 2px;">V/f</span> <span style="background-color: #cccccc; padding: 2px;">CL-V/f</span> <span style="background-color: #cccccc; padding: 2px;">OLV</span> <span style="background-color: #cccccc; padding: 2px;">CLV</span> <span style="background-color: #cccccc; padding: 2px;">AOLV</span> <span style="background-color: #cccccc; padding: 2px;">OLV/PM</span> <span style="background-color: #cccccc; padding: 2px;">AOLV/PM</span> <span style="background-color: #cccccc; padding: 2px;">CLV/PM</span> <span style="background-color: #cccccc; padding: 2px;">EZOLV</span><br>Sets the frequency reference in the units from o1-03 [Frequency Display Unit Selection]. | 0.00 Hz<br>(0.00 - 590.00 Hz) |

#### Note:

- The upper limit value changes when the E1-04 [Maximum Output Frequency] and d2-01 [Frequency Reference Upper Limit] values change. Calculate the upper limit value with this formula:  
Upper limit value =  $(E1-04) \times (d2-01) / 100$
- When A1-02 = 6, 7 [Control Method Selection = AOLV/PM, CLV/PM], the drive changes o1-03 = 1 [0.01% (100% = E1-04)].
- To set d1-01 to 1-step speed parameter in a multi-step speed operation, set b1-01 = 0 [Frequency Reference Selection 1 = Keypad].










### ■ d1-02: Reference 2

| No. (Hex.)             | Name        | Description  | Default (Range)               |
|------------------------|-------------|--|-------------------------------|
| d1-02<br>(0281)<br>RUN | Reference 2 |         <br>Sets the frequency reference in the units from o1-03 [Frequency Display Unit Selection]. | 0.00 Hz<br>(0.00 - 590.00 Hz) |

**Note:**

- The upper limit value changes when the E1-04 [Maximum Output Frequency] and d2-01 [Frequency Reference Upper Limit] values change.
- When A1-02 = 6, 7 [Control Method Selection = AOLV/PM, CLV/PM], the drive changes o1-03 = 1 [0.01% (100% = E1-04)].
- To set d1-02 to Multi-Step Speed 2, set H3-02, H3-06, and H3-10 ≠ 2 [MFAI Function Select ≠ Auxiliary Frequency Reference 1]. When the status is the default setting, set H3-06 = F [Terminal A3 Function Selection = Not Used].










### ■ d1-03: Reference 3

| No. (Hex.)             | Name        | Description  | Default (Range)               |
|------------------------|-------------|--|-------------------------------|
| d1-03<br>(0282)<br>RUN | Reference 3 |         <br>Sets the frequency reference in the units from o1-03 [Frequency Display Unit Selection]. | 0.00 Hz<br>(0.00 - 590.00 Hz) |

**Note:**

- The upper limit value changes when the E1-04 [Maximum Output Frequency] and d2-01 [Frequency Reference Upper Limit] values change.
- When A1-02 = 6, 7 [Control Method Selection = AOLV/PM, CLV/PM], the drive changes o1-03 = 1 [0.01% (100% = E1-04)].
- To set d1-03 to Multi-Step Speed 3, set H3-02, H3-06, and H3-10 ≠ 3 [MFAI Function Select ≠ Auxiliary Frequency Reference 2].










### ■ d1-04: Reference 4

| No. (Hex.)             | Name        | Description  | Default (Range)               |
|------------------------|-------------|--|-------------------------------|
| d1-04<br>(0283)<br>RUN | Reference 4 |         <br>Sets the frequency reference in the units from o1-03 [Frequency Display Unit Selection]. | 0.00 Hz<br>(0.00 - 590.00 Hz) |

**Note:**

- The upper limit value changes when the E1-04 [Maximum Output Frequency] and d2-01 [Frequency Reference Upper Limit] values change.
- When A1-02 = 6, 7 [Control Method Selection = AOLV/PM, CLV/PM], the drive changes o1-03 = 1 [0.01% (100% = E1-04)].
- This parameter sets the frequency reference of Multi-Step Speed 4.










### ■ d1-05: Reference 5

| No. (Hex.)             | Name        | Description  | Default (Range)               |
|------------------------|-------------|--|-------------------------------|
| d1-05<br>(0284)<br>RUN | Reference 5 |         <br>Sets the frequency reference in the units from o1-03 [Frequency Display Unit Selection]. | 0.00 Hz<br>(0.00 - 590.00 Hz) |

**Note:**

- The upper limit value changes when the E1-04 [Maximum Output Frequency] and d2-01 [Frequency Reference Upper Limit] values change.
- When A1-02 = 6, 7 [Control Method Selection = AOLV/PM, CLV/PM], the drive changes o1-03 = 1 [0.01% (100% = E1-04)].
- This parameter sets the frequency reference of Multi-Step Speed 5.

### ■ d1-06: Reference 6

| No. (Hex.)             | Name        | Description  | Default (Range)               |
|------------------------|-------------|--|-------------------------------|
| d1-06<br>(0285)<br>RUN | Reference 6 |         <br>Sets the frequency reference in the units from o1-03 [Frequency Display Unit Selection]. | 0.00 Hz<br>(0.00 - 590.00 Hz) |

## 2.5 d: Softstarter

**Note:**

- The upper limit value changes when the *E1-04 [Maximum Output Frequency]* and *d2-01 [Frequency Reference Upper Limit]* values change.
- When *A1-02 = 6, 7 [Control Method Selection = AOLV/PM, CLV/PM]*, the drive changes *o1-03 = 1 [0.01% (100% = E1-04)]*.
- This parameter sets the frequency reference of Multi-Step Speed 6.

### ■ d1-07: Reference 7

| No. (Hex.)             | Name        | Description  | Default (Range)               |
|------------------------|-------------|--|-------------------------------|
| d1-07<br>(0286)<br>RUN | Reference 7 | <div style="display: flex; justify-content: space-between; font-size: 0.8em; font-weight: bold; background-color: #333; color: white; padding: 2px;"> <span>V/f</span> <span>CL-V/f</span> <span>OLV</span> <span>CLV</span> <span>AOLV</span> <span>OLV/PM</span> <span>AOLV/PM</span> <span>CLV/PM</span> <span>EZOLV</span> </div> Sets the frequency reference in the units from <i>o1-03 [Frequency Display Unit Selection]</i> . | 0.00 Hz<br>(0.00 - 590.00 Hz) |

**Note:**

- The upper limit value changes when the *E1-04 [Maximum Output Frequency]* and *d2-01 [Frequency Reference Upper Limit]* values change.
- When *A1-02 = 6, 7 [Control Method Selection = AOLV/PM, CLV/PM]*, the drive changes *o1-03 = 1 [0.01% (100% = E1-04)]*.
- This parameter sets the frequency reference of Multi-Step Speed 7.

### ■ d1-08: Reference 8

| No. (Hex.)             | Name        | Description  | Default (Range)               |
|------------------------|-------------|--|-------------------------------|
| d1-08<br>(0287)<br>RUN | Reference 8 | <div style="display: flex; justify-content: space-between; font-size: 0.8em; font-weight: bold; background-color: #333; color: white; padding: 2px;"> <span>V/f</span> <span>CL-V/f</span> <span>OLV</span> <span>CLV</span> <span>AOLV</span> <span>OLV/PM</span> <span>AOLV/PM</span> <span>CLV/PM</span> <span>EZOLV</span> </div> Sets the frequency reference in the units from <i>o1-03 [Frequency Display Unit Selection]</i> . | 0.00 Hz<br>(0.00 - 590.00 Hz) |

**Note:**

- The upper limit value changes when the *E1-04 [Maximum Output Frequency]* and *d2-01 [Frequency Reference Upper Limit]* values change.
- When *A1-02 = 6, 7 [Control Method Selection = AOLV/PM, CLV/PM]*, the drive changes *o1-03 = 1 [0.01% (100% = E1-04)]*.
- This parameter sets the frequency reference of Multi-Step Speed 8.

### ■ d1-09: Reference 9

| No. (Hex.)             | Name        | Description  | Default (Range)               |
|------------------------|-------------|--|-------------------------------|
| d1-09<br>(0288)<br>RUN | Reference 9 | <div style="display: flex; justify-content: space-between; font-size: 0.8em; font-weight: bold; background-color: #333; color: white; padding: 2px;"> <span>V/f</span> <span>CL-V/f</span> <span>OLV</span> <span>CLV</span> <span>AOLV</span> <span>OLV/PM</span> <span>AOLV/PM</span> <span>CLV/PM</span> <span>EZOLV</span> </div> Sets the frequency reference in the units from <i>o1-03 [Frequency Display Unit Selection]</i> . | 0.00 Hz<br>(0.00 - 590.00 Hz) |

**Note:**

- The upper limit value changes when the *E1-04 [Maximum Output Frequency]* and *d2-01 [Frequency Reference Upper Limit]* values change.
- When *A1-02 = 6, 7 [Control Method Selection = AOLV/PM, CLV/PM]*, the drive changes *o1-03 = 1 [0.01% (100% = E1-04)]*.
- This parameter sets the frequency reference of Multi-Step Speed 9.

### ■ d1-10: Reference 10

| No. (Hex.)             | Name         | Description  | Default (Range)               |
|------------------------|--------------|--|-------------------------------|
| d1-10<br>(028B)<br>RUN | Reference 10 | <div style="display: flex; justify-content: space-between; font-size: 0.8em; font-weight: bold; background-color: #333; color: white; padding: 2px;"> <span>V/f</span> <span>CL-V/f</span> <span>OLV</span> <span>CLV</span> <span>AOLV</span> <span>OLV/PM</span> <span>AOLV/PM</span> <span>CLV/PM</span> <span>EZOLV</span> </div> Sets the frequency reference in the units from <i>o1-03 [Frequency Display Unit Selection]</i> . | 0.00 Hz<br>(0.00 - 590.00 Hz) |

**Note:**

- The upper limit value changes when the *E1-04 [Maximum Output Frequency]* and *d2-01 [Frequency Reference Upper Limit]* values change.
- When *A1-02 = 6, 7 [Control Method Selection = AOLV/PM, CLV/PM]*, the drive changes *o1-03 = 1 [0.01% (100% = E1-04)]*.
- This parameter sets the frequency reference of Multi-Step Speed 10.

### ■ d1-11: Reference 11

| No. (Hex.)             | Name         | Description  | Default (Range)               |
|------------------------|--------------|--|-------------------------------|
| d1-11<br>(028C)<br>RUN | Reference 11 | <div style="display: flex; justify-content: space-between; align-items: center;"> <span>V/f</span> <span>CL-V/f</span> <span>OLV</span> <span>CLV</span> <span>AOLV</span> <span>OLV/PM</span> <span>AOLV/PM</span> <span>CLV/PM</span> <span>EZOLV</span> </div> Sets the frequency reference in the units from o1-03 [Frequency Display Unit Selection]. | 0.00 Hz<br>(0.00 - 590.00 Hz) |

**Note:**

- The upper limit value changes when the E1-04 [Maximum Output Frequency] and d2-01 [Frequency Reference Upper Limit] values change.
- When A1-02 = 6, 7 [Control Method Selection = AOLV/PM, CLV/PM], the drive changes o1-03 = 1 [0.01% (100% = E1-04)].
- This parameter sets the frequency reference of Multi-Step Speed 11.

### ■ d1-12: Reference 12

| No. (Hex.)             | Name         | Description  | Default (Range)               |
|------------------------|--------------|--|-------------------------------|
| d1-12<br>(028D)<br>RUN | Reference 12 | <div style="display: flex; justify-content: space-between; align-items: center;"> <span>V/f</span> <span>CL-V/f</span> <span>OLV</span> <span>CLV</span> <span>AOLV</span> <span>OLV/PM</span> <span>AOLV/PM</span> <span>CLV/PM</span> <span>EZOLV</span> </div> Sets the frequency reference in the units from o1-03 [Frequency Display Unit Selection]. | 0.00 Hz<br>(0.00 - 590.00 Hz) |

**Note:**

- The upper limit value changes when the E1-04 [Maximum Output Frequency] and d2-01 [Frequency Reference Upper Limit] values change.
- When A1-02 = 6, 7 [Control Method Selection = AOLV/PM, CLV/PM], the drive changes o1-03 = 1 [0.01% (100% = E1-04)].
- This parameter sets the frequency reference of Multi-Step Speed 12.

### ■ d1-13: Reference 13

| No. (Hex.)             | Name         | Description  | Default (Range)               |
|------------------------|--------------|--|-------------------------------|
| d1-13<br>(028E)<br>RUN | Reference 13 | <div style="display: flex; justify-content: space-between; align-items: center;"> <span>V/f</span> <span>CL-V/f</span> <span>OLV</span> <span>CLV</span> <span>AOLV</span> <span>OLV/PM</span> <span>AOLV/PM</span> <span>CLV/PM</span> <span>EZOLV</span> </div> Sets the frequency reference in the units from o1-03 [Frequency Display Unit Selection]. | 0.00 Hz<br>(0.00 - 590.00 Hz) |

**Note:**

- The upper limit value changes when the E1-04 [Maximum Output Frequency] and d2-01 [Frequency Reference Upper Limit] values change.
- When A1-02 = 6, 7 [Control Method Selection = AOLV/PM, CLV/PM], the drive changes o1-03 = 1 [0.01% (100% = E1-04)].
- This parameter sets the frequency reference of Multi-Step Speed 13.

### ■ d1-14: Reference 14

| No. (Hex.)             | Name         | Description  | Default (Range)               |
|------------------------|--------------|--|-------------------------------|
| d1-14<br>(028F)<br>RUN | Reference 14 | <div style="display: flex; justify-content: space-between; align-items: center;"> <span>V/f</span> <span>CL-V/f</span> <span>OLV</span> <span>CLV</span> <span>AOLV</span> <span>OLV/PM</span> <span>AOLV/PM</span> <span>CLV/PM</span> <span>EZOLV</span> </div> Sets the frequency reference in the units from o1-03 [Frequency Display Unit Selection]. | 0.00 Hz<br>(0.00 - 590.00 Hz) |

**Note:**

- The upper limit value changes when the E1-04 [Maximum Output Frequency] and d2-01 [Frequency Reference Upper Limit] values change.
- When A1-02 = 6, 7 [Control Method Selection = AOLV/PM, CLV/PM], the drive changes o1-03 = 1 [0.01% (100% = E1-04)].
- This parameter sets the frequency reference of Multi-Step Speed 14.

### ■ d1-15: Reference 15

| No. (Hex.)             | Name         | Description  | Default (Range)               |
|------------------------|--------------|--|-------------------------------|
| d1-15<br>(0290)<br>RUN | Reference 15 | <div style="display: flex; justify-content: space-between; align-items: center;"> <span>V/f</span> <span>CL-V/f</span> <span>OLV</span> <span>CLV</span> <span>AOLV</span> <span>OLV/PM</span> <span>AOLV/PM</span> <span>CLV/PM</span> <span>EZOLV</span> </div> Sets the frequency reference in the units from o1-03 [Frequency Display Unit Selection]. | 0.00 Hz<br>(0.00 - 590.00 Hz) |

## 2.5 d: Softstarter

### Note:

- The upper limit value changes when the *E1-04* [Maximum Output Frequency] and *d2-01* [Frequency Reference Upper Limit] values change.
- When *A1-02* = 6, 7 [Control Method Selection = AOLV/PM, CLV/PM], the drive changes *o1-03* = 1 [0.01% (100% = E1-04)].
- This parameter sets the frequency reference of Multi-Step Speed 15.

### ■ d1-16: Reference 16

| No. (Hex.)             | Name         | Description   | Default (Range)               |
|------------------------|--------------|---|-------------------------------|
| d1-16<br>(0291)<br>RUN | Reference 16 | <b>V/f</b> <b>CL-V/f</b> <b>OLV</b> <b>CLV</b> <b>AOLV</b> <b>OLV/PM</b> <b>AOLV/PM</b> <b>CLV/PM</b> <b>EZOLV</b><br>Sets the frequency reference in the units from <i>o1-03</i> [Frequency Display Unit Selection]. | 0.00 Hz<br>(0.00 - 590.00 Hz) |

### Note:

- The upper limit value changes when the *E1-04* [Maximum Output Frequency] and *d2-01* [Frequency Reference Upper Limit] values change.
- When *A1-02* = 6, 7 [Control Method Selection = AOLV/PM, CLV/PM], the drive changes *o1-03* = 1 [0.01% (100% = E1-04)].
- This parameter sets the frequency reference of Multi-Step Speed 16.

### ■ d1-17: Jog Reference

| No. (Hex.)             | Name          | Description   | Default (Range)               |
|------------------------|---------------|---|-------------------------------|
| d1-17<br>(0292)<br>RUN | Jog Reference | <b>V/f</b> <b>CL-V/f</b> <b>OLV</b> <b>CLV</b> <b>AOLV</b> <b>OLV/PM</b> <b>AOLV/PM</b> <b>CLV/PM</b> <b>EZOLV</b><br>Sets the Jog frequency reference in the units from <i>o1-03</i> [Frequency Display Unit Selection]. Set <i>H1-xx</i> = 6 [MFDI Function Select = Jog Reference Selection] to use the Jog frequency reference. | 6.00 Hz<br>(0.00 - 590.00 Hz) |

### Note:

- The upper limit value changes when the *E1-04* [Maximum Output Frequency] and *d2-01* [Frequency Reference Upper Limit] values change.
- When *A1-02* = 6, 7 [Control Method Selection = AOLV/PM, CLV/PM], the drive changes *o1-03* = 1 [0.01% (100% = E1-04)].

## ◆ d2: Reference Limits

*d2* parameters set the upper and lower frequency limits to control the motor speed. Apply these parameters to for example, run the motor at low-speed due to mechanical strength concerns, or if the motor should not be run at low speed because of lubrication issues with the gears and bearings.

The upper frequency limit is set in *d2-01* [Frequency Reference Upper Limit] and the lower limit is set in *d2-02* [Frequency Reference Lower Limit].

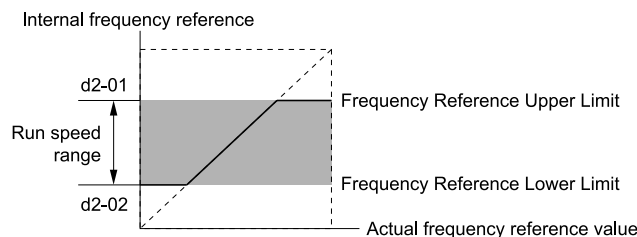


Figure 2.61 Upper and Lower Frequency Limits

### ■ d2-01: Frequency Reference Upper Limit

| No. (Hex.)      | Name                            | Description  | Default (Range)          |
|-----------------|---------------------------------|--|--------------------------|
| d2-01<br>(0289) | Frequency Reference Upper Limit | <b>V/f</b> <b>CL-V/f</b> <b>OLV</b> <b>CLV</b> <b>AOLV</b> <b>OLV/PM</b> <b>AOLV/PM</b> <b>CLV/PM</b> <b>EZOLV</b><br>Sets maximum limit for all frequency references. The maximum output frequency is 100%. | 100.0%<br>(0.0 - 110.0%) |

When the frequency reference is more than the value set in *d2-01* the drive will continue to operate at the value set in *d2-01*.

### ■ d2-02: Frequency Reference Lower Limit

| No. (Hex.)   | Name                            | Description  | Default (Range)        |
|--------------|---------------------------------|--|------------------------|
| d2-02 (028A) | Frequency Reference Lower Limit | <b>V/f</b> <b>CL-V/f</b> <b>OLV</b> <b>CLV</b> <b>AOLV</b> <b>OLV/PM</b> <b>AOLV/PM</b> <b>CLV/PM</b> <b>EZOLV</b><br>Sets minimum limit for all frequency references. The maximum output frequency is 100%. | 0.0%<br>(0.0 - 110.0%) |

When the frequency reference is less than the value set in *d2-02*, the drive will continue to operate at the value set in *d2-02*. The motor will accelerate to the *d2-02* value after the drive receives a Run command and a lower frequency reference than *d2-02* has been entered.

### ■ d2-03: Analog Frequency Ref Lower Limit

| No. (Hex.)   | Name                             | Description  | Default (Range)        |
|--------------|----------------------------------|--|------------------------|
| d2-03 (0293) | Analog Frequency Ref Lower Limit | <b>V/f</b> <b>CL-V/f</b> <b>OLV</b> <b>CLV</b> <b>AOLV</b> <b>OLV/PM</b> <b>AOLV/PM</b> <b>CLV/PM</b> <b>EZOLV</b><br>Sets the lower limit for the master frequency reference (the first frequency of the multi-step speed reference) as a percentage. The maximum output frequency is 100%. | 0.0%<br>(0.0 - 110.0%) |

This parameter does not change the lower limit of Jog reference, frequency reference for multi-step speed operation, or the auxiliary frequency reference.

The drive operates at the value set in *d2-03* when the frequency reference decreases to less than the value set in *d2-03*.

**Note:**

When lower limits are set to parameters *d2-02* [*Frequency Reference Lower Limit*] and *d2-03*, the drive uses the larger value as the lower limit.

### ◆ d3: Jump Frequency

The Jump frequency is a function that sets the dead band to a specified frequency band. If a machine that operated at constant speed is operated with variable speed, it can make resonance. To operate the machine without resonance from the natural frequency of the machinery mechanical system, use a frequency band jump.

You can program the drive to have three different Jump frequencies. Set *d3-01* to *d3-03* [*Jump Frequencies*] to the median value for the jumped frequency and set *d3-04* [*Jump Frequency Width*] to the Jump frequency width.

When you input a frequency reference that is the same as or near the Jump frequency width, the frequency reference changes automatically.

The drive accelerates or decelerates the motor smoothly until the frequency reference is not in the range of the Jump frequency band. The drive will use the active accel/decel time to go through the specified dead band range. If the frequency reference is not in the range of the Jump frequency band, switch to constant speed operation.

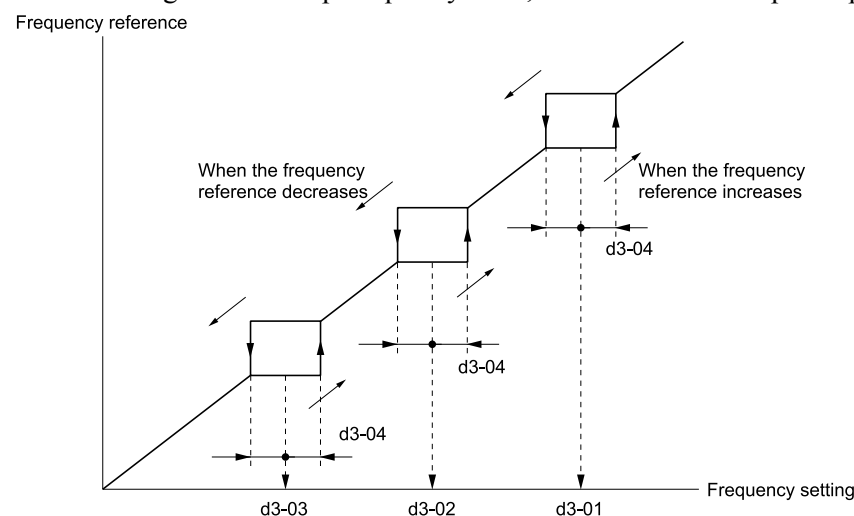


Figure 2.62 Jump Frequency

## 2.5 d: Softstarter

**Note:**

- When you set Jump Frequencies 1 to 3, make sure that the parameters do not overlap.
- When the drive is in the range of the Jump frequency, the frequency reference changes automatically. When Jump is executed, the output frequency changes smoothly as specified by the values set in *C1-01 [Acceleration Time 1]* and *C1-02 [Deceleration Time 1]*.

### ■ d3-01: Jump Frequency 1

| No. (Hex.)      | Name             | Description  | Default (Range)                 |
|-----------------|------------------|--|---------------------------------|
| d3-01<br>(0294) | Jump Frequency 1 | <b>V/f</b> <b>CL-V/f</b> <b>OLV</b> <b>CLV</b> <b>AOLV</b> <b>OLV/PM</b> <b>AOLV/PM</b> <b>CLV/PM</b> <b>EZOLV</b><br>Sets the median value of the frequency band that the drive will avoid. | 0.0 Hz<br>(Determined by A1-02) |

**Note:**

Set this parameter to 0.0 Hz to disable the Jump frequency.

### ■ d3-02: Jump Frequency 2

| No. (Hex.)      | Name             | Description  | Default (Range)                 |
|-----------------|------------------|--|---------------------------------|
| d3-02<br>(0295) | Jump Frequency 2 | <b>V/f</b> <b>CL-V/f</b> <b>OLV</b> <b>CLV</b> <b>AOLV</b> <b>OLV/PM</b> <b>AOLV/PM</b> <b>CLV/PM</b> <b>EZOLV</b><br>Sets the median value of the frequency band that the drive will avoid. | 0.0 Hz<br>(Determined by A1-02) |

**Note:**

Set this parameter to 0.0 Hz to disable the Jump frequency.

### ■ d3-03: Jump Frequency 3

| No. (Hex.)      | Name             | Description  | Default (Range)                 |
|-----------------|------------------|--|---------------------------------|
| d3-03<br>(0296) | Jump Frequency 3 | <b>V/f</b> <b>CL-V/f</b> <b>OLV</b> <b>CLV</b> <b>AOLV</b> <b>OLV/PM</b> <b>AOLV/PM</b> <b>CLV/PM</b> <b>EZOLV</b><br>Sets the median value of the frequency band that the drive will avoid. | 0.0 Hz<br>(Determined by A1-02) |

**Note:**

Set this parameter to 0.0 Hz to disable the Jump frequency.

### ■ d3-04: Jump Frequency Width

| No. (Hex.)      | Name                 | Description   | Default (Range)                 |
|-----------------|----------------------|---|---------------------------------|
| d3-04<br>(0297) | Jump Frequency Width | <b>V/f</b> <b>CL-V/f</b> <b>OLV</b> <b>CLV</b> <b>AOLV</b> <b>OLV/PM</b> <b>AOLV/PM</b> <b>CLV/PM</b> <b>EZOLV</b><br>Sets the width of the frequency band that the drive will avoid. | 1.0 Hz<br>(Determined by A1-02) |

## ◆ d4: Frequency Ref Up/Down & Hold

The *d4 parameters* set the Frequency Reference Hold function and Up/Down and Up/Down 2 commands.

**WARNING! Sudden Movement Hazard.** When you use the drive in a lifting application, you must also install external safety circuitry. The drive does not have protection against accidental load drops in lifting applications. Install electrical and/or mechanical safety circuit mechanisms that are isolated from the drive circuitry. If you do not use external safety circuitry, the drive could drop the load and cause serious injury or death.

- Frequency Reference Hold Function Command: This acceleration/deceleration ramp hold command uses an MFDI to momentarily stop the acceleration/deceleration of the motor, and continues to operate the motor at the output frequency at which the command reference was input. Turn OFF the acceleration/deceleration ramp hold command to continue acceleration/deceleration.
- Up/Down command: The Up/Down command is a function to activate and deactivate an MFDI to increase and decrease the frequency reference. The Up/Down command overrides frequency references from the analog input terminal, pulse train input terminal, and keypad.
- Up/Down 2 command: The Up/Down 2 command is a function that adds a set bias value to the frequency reference to accelerate or decelerate. The Up/Down 2 command activates and deactivates the MFDI to add a bias value.



## ■ d4-01: Freq Reference Hold Selection

| No. (Hex.)   | Name                          | Description  | Default (Range) |
|--------------|-------------------------------|--|-----------------|
| d4-01 (0298) | Freq Reference Hold Selection | <div style="display: flex; justify-content: space-between; font-size: 0.8em; font-weight: bold;"> <span>V/f</span> <span>CL-V/f</span> <span>OLV</span> <span>CLV</span> <span>AOLV</span> <span>OLV/PM</span> <span>AOLV/PM</span> <span>CLV/PM</span> <span>EZOLV</span> </div> Sets the function that saves the frequency reference or the frequency bias (Up/Down 2) after a Stop command or when de-energizing the drive. | 0 (0, 1)        |

Set *H1-xx [MFDI Function Select]* to one of these values to enable this parameter:

- *A [Accel/Decel Ramp Hold]*
- *10/11 [Up/Down Command]*
- *75/76 [Up/Down 2 Command]*

### 0 : No

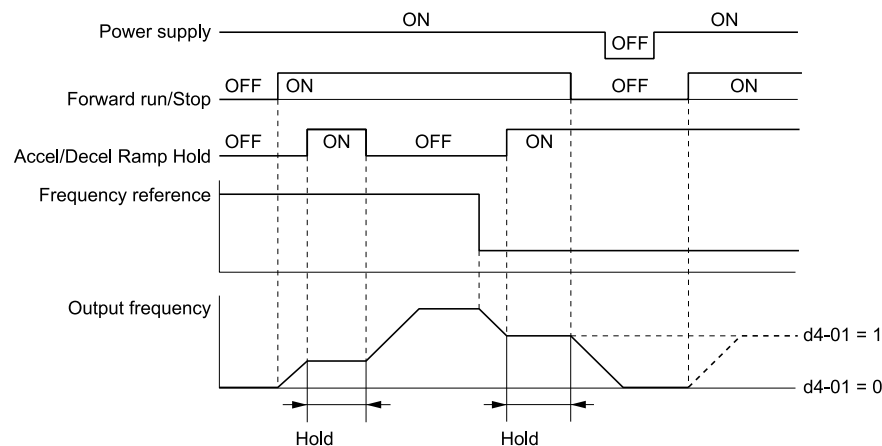
- **Acceleration/Deceleration Ramp Hold**  
When you enter a Stop command or de-energize the drive, the hold value is reset to 0 Hz. The drive will use the active frequency reference when it restarts.
- **Up/Down Command**  
When you enter a Stop command or de-energize the drive, the frequency reference value is reset to 0 Hz. The drive will start from 0 Hz when it restarts.
- **Combined with the Up/Down 2 Command**  
When you enter the Stop command or 5 s after you release the Up/Down 2 command, the drive does not save the frequency bias. The Up/Down 2 function will start with a bias of 0% when the drive restarts.

### 1 : Yes

- **Acceleration/Deceleration Ramp Hold**  
When you clear the Run command or de-energize the drive, it will save the last hold value. The drive will use the saved value as the frequency reference when it restarts.

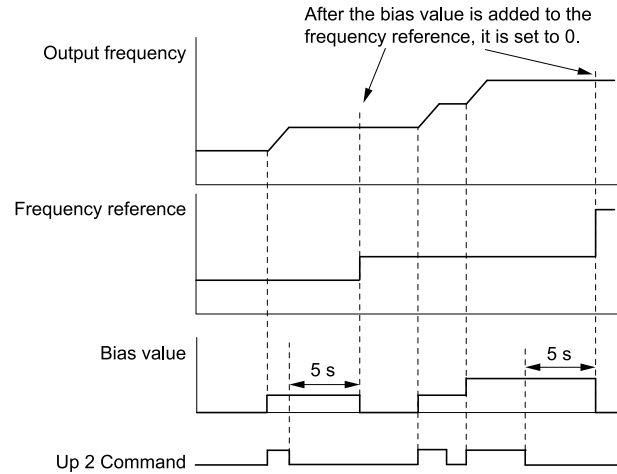
#### Note:

When you energize the drive, continuously enable the MFDI terminal set for *Accel/Decel Ramp Hold [H1-xx = A]*. If the digital input does not activate, the drive will clear the hold value and set it to 0 Hz.



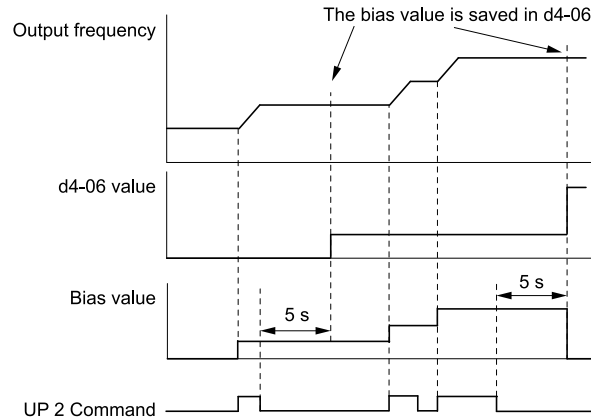
**Figure 2.63 Frequency Reference Hold with Accel/Decel Hold Function**

- **Up/Down Command**  
When you clear the Run command or de-energize the drive, it will save the frequency reference value. The drive will use the saved value as the frequency reference when it restarts.
- **Up/Down 2 Command with Frequency Reference from Keypad**  
When a Run command is active and you release the Up/Down 2 command for longer than 5 s, the drive adds the Up/Down 2 bias value to the frequency reference and sets it to 0. The drive saves the frequency reference value to which the bias value was added. The drive will use the new value as the frequency reference when it restarts.



**Figure 2.64 Up/Down 2 Example with Reference from Keypad and d4-01 = 1**

- Up/Down 2 Command with Frequency Reference from Input Sources Other Than the Keypad  
When a Run command is active and you release the Up/Down 2 command for longer than 5 s, the drive will save the bias value in *d4-06* [Frequency Ref Bias (Up/Down 2)]. The drive saves the frequency reference + *d4-06* as a frequency reference value. The drive will use the new value as the frequency reference when it restarts.



**Figure 2.65 Up/Down 2 Example with Other Reference than Keypad and d4-01 = 1**

**Note:**

To use the combination of the frequency reference hold function and the Up/Down 2 function, configure the Up/Down 2 upper limit [*d4-08*] and lower limit [*d4-09*] correctly.

**Remove the Saved Frequency Reference Value**

The procedure to remove the saved frequency reference value is different for different functions. Use these methods to remove the value:

- Release the input programmed for *Accel/Decel Ramp Hold* [*H1-xx = A*].
- Set an Up or Down command while no Run command is active.
- Use the Up/Down 2 Command to set *d4-06* = 0.0 or set *d4-06* = 0.0 during stop.

**■ d4-03: Up/Down 2 Bias Step Frequency**

| No. (Hex.)       | Name                          | Description  | Default (Range)              |
|------------------|-------------------------------|--|------------------------------|
| d4-03 (02AA) RUN | Up/Down 2 Bias Step Frequency | <b>V/f</b> <b>CL-V/f</b> <b>OLV</b> <b>CLV</b> <b>AOLV</b> <b>OLV/PM</b> <b>AOLV/PM</b> <b>CLV/PM</b> <b>EZOLV</b><br>Sets the bias that the Up/Down 2 function adds to or subtracts from the frequency reference. | 0.00 Hz<br>(0.00 - 99.99 Hz) |

The operation is different for different setting values:

- **Setting d4-03 = 0.00 Hz**

When the *Up/Down 2 Command* [ $H1-xx = 75, 76$ ] is active, the drive uses the accel/decel times set in  $d4-04$  [*Up/Down 2 Ramp Selection*] to increase or decrease the bias value.

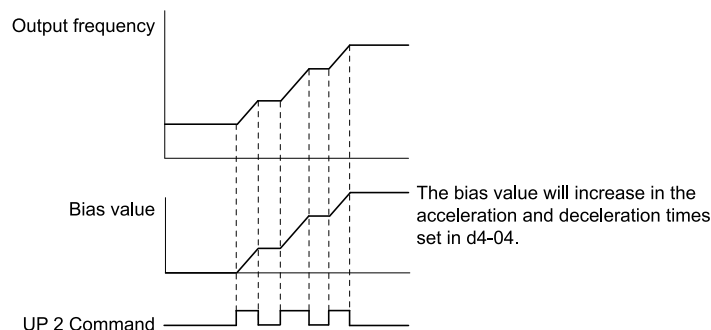


Figure 2.66 Up/Down 2 Bias when  $d4-03 = 0.00$  Hz

- **Setting  $d4-03 \neq 0.00$  Hz**

When the *Up/Down 2 Command* [ $H1-xx = 75, 76$ ] is active, the drive increases or decreases the bias in steps for the value set in  $d4-03$ . The drive uses the acceleration and deceleration times set in  $d4-04$ .

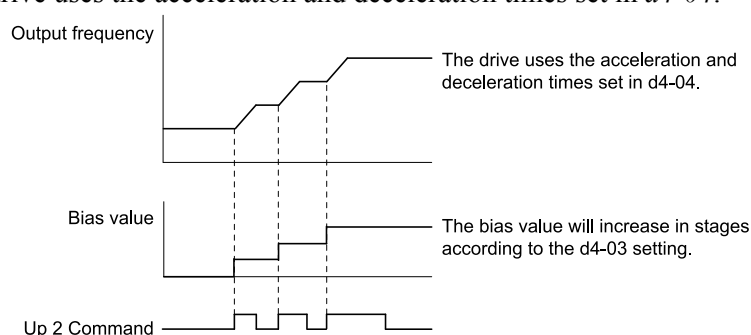


Figure 2.67 Up/Down 2 Bias when  $d4-03 \neq 0.00$  Hz

### ■ $d4-04$ : Up/Down 2 Ramp Selection

| No. (Hex.)             | Name                     | Description   | Default (Range) |
|------------------------|--------------------------|---|-----------------|
| d4-04<br>(02AB)<br>RUN | Up/Down 2 Ramp Selection | <b>V/f</b> <b>CL-V/f</b> <b>OLV</b> <b>CLV</b> <b>AOLV</b> <b>OLV/PM</b> <b>AOLV/PM</b> <b>CLV/PM</b> <b>EZOLV</b><br>Sets the acceleration and deceleration times for the Up/Down 2 function to apply the bias to the frequency reference. | 0<br>(0, 1)     |

#### 0 : Use Selected Accel/Decel Time

Use the active acceleration and deceleration times to increase or decrease the bias.

#### 1 : Use Accel/Decel Time 4

Use  $C1-07$  [*Acceleration Time 4*] and  $C1-08$  [*Deceleration Time 4*] to increase or decrease the bias.

### ■ $d4-05$ : Up/Down 2 Bias Mode Selection

| No. (Hex.)             | Name                          | Description  | Default (Range) |
|------------------------|-------------------------------|--|-----------------|
| d4-05<br>(02AC)<br>RUN | Up/Down 2 Bias Mode Selection | <b>V/f</b> <b>CL-V/f</b> <b>OLV</b> <b>CLV</b> <b>AOLV</b> <b>OLV/PM</b> <b>AOLV/PM</b> <b>CLV/PM</b> <b>EZOLV</b><br>Sets the function that saves the bias value to the drive when you open or close the two <i>Up/Down 2 Commands</i> [ $H1-xx = 75, 76$ ]. Set $d4-03$ [ <i>Up/Down 2 Bias Step Frequency</i> ] = 0.00 before you set this parameter. | 0<br>(0, 1)     |

#### 0 : Hold when Neither Up/Down Closed

When the two MFDI terminals set for *Up/Down 2 Command* [ $H1-xx = 75, 76$ ] activate or deactivate, the drive will hold the bias value.

#### 1 : Reset when Neither / Both Closed

When the two MFDI terminals set for *Up/Down 2 Command* [ $H1-xx = 75, 76$ ] activate or deactivate, the drive will reset the bias value to 0. The drive will use the acceleration and deceleration times set in  $d4-04$  [*Up/Down 2 Ramp Selection*] to accelerate and decelerate the motor to the selected output frequency.

### ■ d4-06: Frequency Ref Bias (Up/Down 2)

| No.<br>(Hex.)   | Name                 | Description   | Default<br>(Range)        |
|-----------------|----------------------|---|---------------------------|
| d4-06<br>(02AD) | UP/DOWN 2 Bias Value | <div style="display: flex; justify-content: space-between; font-size: 0.8em;"> <span>V/f</span> <span>CL-V/f</span> <span>OLV</span> <span>CLV</span> <span>AOLV</span> <span>OLV/PM</span> <span>AOLV/PM</span> <span>CLV/PM</span> <span>EZOLV</span> </div> <p>Saves the bias value from the Up/Down 2 Command assuming that the Maximum Output Frequency is 100%.</p> | 0.0%<br>(-99.9 - +100.0%) |

The Up/Down 2 function setting changes the function of *d4-06*:

**Note:**

When the keypad sets the frequency reference, you do not usually use parameter *d4-06*.

- When *d4-01* = 0 [*Freq Reference Hold Selection = Disabled*] and a source other than the keypad sets the frequency reference, the drive adds the value set in *d4-06* to the frequency reference. If the value set in *d4-06* is a negative number, the drive will subtract it from frequency reference.
- When *d4-01* = 1 [*Enabled*] and a source other than the keypad sets the frequency reference, the drive will store the bias value adjusted with the Up/Down 2 command in *d4-06* 5 seconds after you release the Up/Down 2 command. The drive adds or subtracts the value set in *d4-06* to the frequency reference.

**Conditions that Reset or Disable d4-06**

The drive resets and disables the bias value in these conditions:

- *d4-01* = 0 and the Run command was cleared.
- *H1-xx* = 75, 76 [*MFDI Function Select = Up/Down 2 Command*] is not set.
- The frequency reference source was changed.  
This includes switching LOCAL/REMOTE and multi-step speed reference.
- A digital input changed the frequency reference value.
- *d4-03* [*Up/Down 2 Bias Step Frequency*] = 0 and *d4-05* = 1 [*Up/Down 2 Bias Mode Selection = Reset when Neither / Both Closed*], and the two MFDI terminals set for *Up/Down 2 Command* [*H1-xx* = 75/76] are activated or deactivated.
- The value of *E1-04* [*Maximum Output Frequency*] was changed.

### ■ d4-07: Analog Freq Ref Fluctuate Limit

| No.<br>(Hex.)          | Name                            | Description   | Default<br>(Range)     |
|------------------------|---------------------------------|---|------------------------|
| d4-07<br>(02AE)<br>RUN | Analog Freq Ref Fluctuate Limit | <div style="display: flex; justify-content: space-between; font-size: 0.8em;"> <span>V/f</span> <span>CL-V/f</span> <span>OLV</span> <span>CLV</span> <span>AOLV</span> <span>OLV/PM</span> <span>AOLV/PM</span> <span>CLV/PM</span> <span>EZOLV</span> </div> <p>If the frequency reference changes for more than the level set to this parameter, then the bias value will be held. The value is set as a percentage of the Maximum Output Frequency.</p> | 1.0%<br>(0.1 - 100.0%) |

Handles frequency reference changes while *Up/Down 2 Command* [*H1-xx* = 75, 76] is activated. When the frequency reference changes for more than the level set in *d4-07*, the drive will hold the bias value, and the drive will accelerate or decelerate to the frequency reference. When the drive is at the frequency reference, it releases the bias hold and the bias follows the Up/Down 2 input commands.

This parameter is applicable only when an analog or pulse input sets the frequency reference.

### ■ d4-08: Up/Down 2 Bias Upper Limit

| No.<br>(Hex.)          | Name                       | Description   | Default<br>(Range)       |
|------------------------|----------------------------|---|--------------------------|
| d4-08<br>(02AF)<br>RUN | Up/Down 2 Bias Upper Limit | <div style="display: flex; justify-content: space-between; font-size: 0.8em;"> <span>V/f</span> <span>CL-V/f</span> <span>OLV</span> <span>CLV</span> <span>AOLV</span> <span>OLV/PM</span> <span>AOLV/PM</span> <span>CLV/PM</span> <span>EZOLV</span> </div> <p>Sets the upper limit of the Up/Down 2 bias as a percentage of the Maximum Output Frequency.</p> | 100.0%<br>(0.0 - 100.0%) |

The drive saves the set bias upper limit in *d4-06* [*Frequency Ref Bias (Up/Down 2)*]. Set *d4-08* an applicable value before you use the Up/Down 2 function.

**Note:**

When *d4-01* = 1 [*Freq Reference Hold Selection = Enabled*] and *b1-01* = 0 [*Freq Reference Selection 1 = Keypad*], the drive will add the bias value to the frequency reference when it does not receive an Up/Down 2 command for 5 s. Then the drive will reset the value to 0 at which time you can increase the bias to the limit set in *d4-08* again.

### ■ d4-09: Up/Down 2 Bias Lower Limit

| No.<br>(Hex.)          | Name                       | Description   | Default<br>(Range)     |
|------------------------|----------------------------|---|------------------------|
| d4-09<br>(02B0)<br>RUN | Up/Down 2 Bias Lower Limit | <b>V/f</b> <b>CL-V/f</b> <b>OLV</b> <b>CLV</b> <b>AOLV</b> <b>OLV/PM</b> <b>AOLV/PM</b> <b>CLV/PM</b> <b>EZOLV</b><br>Sets the lower limit of the Up/Down 2 bias as a percentage of the Maximum Output Frequency. | 0.0%<br>(-99.9 - 0.0%) |

The drive saves the set bias lower limit in *d4-06* [*Frequency Ref Bias (Up/Down 2)*]. Set *d4-09* to an applicable value before you use the Up/Down 2 function.

#### Note:

When *d4-01* = 1 [*Freq Reference Hold Selection = Enabled*] and *b1-01* = 0 [*Frequency Reference Selection 1 = Keypad*], the drive will add the bias value to the frequency reference when it does not receive an Up/Down 2 command for 5 s. Then the drive will reset the value to 0.

If you increase the bias with the Up 2 command and *d4-09* = 0, you cannot use a Down 2 command to decrease the frequency reference. To decrease speed in this condition, set a negative lower limit in *d4-09*.

### ■ d4-10: Up/Down Freq Lower Limit Select

| No.<br>(Hex.)   | Name                            | Description  | Default<br>(Range) |
|-----------------|---------------------------------|--|--------------------|
| d4-10<br>(02B6) | Up/Down Freq Lower Limit Select | <b>V/f</b> <b>CL-V/f</b> <b>OLV</b> <b>CLV</b> <b>AOLV</b> <b>OLV/PM</b> <b>AOLV/PM</b> <b>CLV/PM</b> <b>EZOLV</b><br>Sets the lower frequency limit for the Up/Down function. | 0<br>(0, 1)        |

### 0 : Greater of d2-02 or Analog

The higher value between *d2-02* [*Frequency Reference Lower Limit*] and an analog input programmed for *Frequency Reference* [*H3-02, H3-06, H3-10* = 0] sets the lower frequency reference limit.

#### Note:

When you use *External Reference 1/2 Selection* [*H1-xx* = 2] to switch between the Up/Down function and an analog input as the reference source, the analog value becomes the lower reference limit when the Up/Down command is active. Set *d4-10* = 1 to isolate the Up/Down function and the analog input value.

### 1 : d2-02

You can only use *d2-02* to set the lower limit of the frequency reference.

## ◆ d5: Torque Control

*d5 parameters* set the Torque Control function.

The Torque Control function controls the output torque of the motor. You can use Torque Control for roller drives, winders, unwinders, conveyors and other machines that use tension control and push/pull applications. When there is no more material and the machine suddenly has no load, the drive uses Torque Control and the speed limit function to keep the rotation speed of the motor from increasing.

Set *A1-02* [*Control Method Selection*] to one of these values to use Torque Control:

- 3 [Closed Loop Vector]
- 4 [Advanced Open Loop Vector]
- 6 [PM Advanced Open Loop Vector]
- 7 [PM Closed Loop Vector]

#### Note:

When you use Torque Control and *A1-02* = 4, use a motor designed for winding applications.

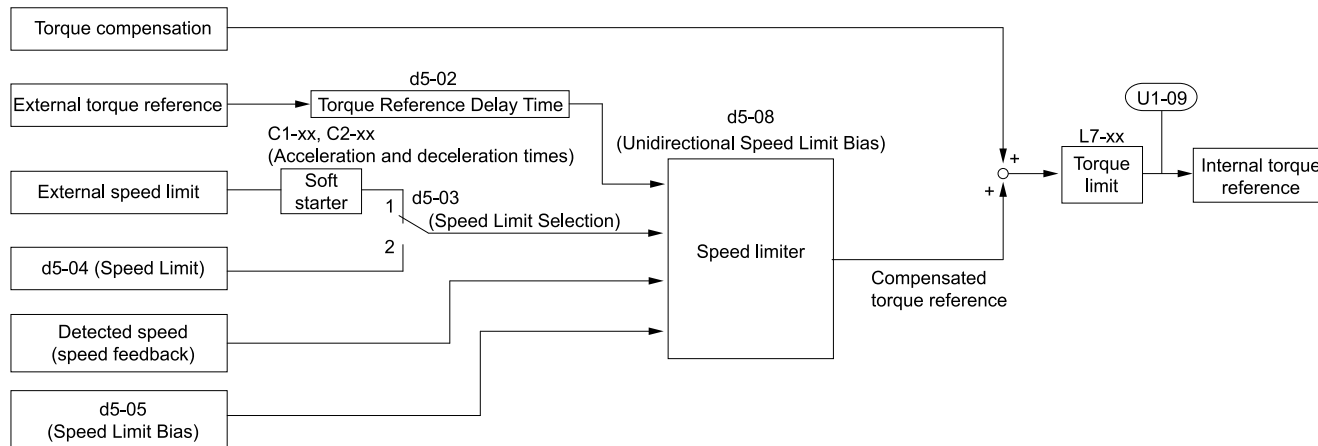
Use one of these methods to enable Torque Control:

- Set *d5-01* = 1 [*Torque Control Selection = Torque Control*].
- Set *H1-xx* = 71 [*Torque Control*] ON.

### ■ Torque Control Operation

Figure 2.68 shows the operation principle of Torque Control.

## 2.5 d: Softstarter



**Figure 2.68 Torque Control Block Diagram**

The externally input torque reference is the target value for the motor output torque. If the motor output torque and load torque are not balanced during Torque Control, the motor accelerates or decelerates. To prevent operation beyond the speed limit, the drive corrects the external torque reference if the motor speed reaches the speed limit. The speed limit, speed feedback, and the speed limit bias are the values that calculate the compensation value.

When an external torque compensation value is input, the drive adds that value to the speed limit compensated torque reference value. The values *L7-01 to L7-04 [Torque Limit]* limit the resulting torque reference. The drive uses the value as the internal torque reference. You can use *U1-09 [Torque Reference]* to monitor the calculated torque reference. The torque limit values set in *L7-01 to L7-04* are most important. Although you can set a higher external torque reference from an external source, the motor will not operate a torque output higher than values set in *L7-01 to L7-04*.

### ■ Setting the Torque Reference, Speed Limit, and Torque Compensation Values

#### Torque Control Input Value Selection

Table 2.38 lists the method for torque control input signals.

**Table 2.38 The Method for Torque Control Input Signals**

| Configuration Parameter | Signal Input Method  | Parameter Settings  | Notes   |
|-------------------------|--|---|---|
| Torque Reference        | Drive analog input terminals A1, A2, A3                              | <i>H3-02, H3-10, H3-06 = 13 [MFAI Function Select = Torque Reference / Torque Limit] *1</i>   | The level of the set input signal must align with the polarity of the external signals.   |
|                         | Analog reference option cards AI-A3                                  | <ul style="list-style-type: none"> <li><i>F2-01 = 0 [Analog Input Function Selection = 3 Independent Channels]</i></li> <li><i>H3-02, H3-10, and H3-06 = 13 *1</i></li> </ul>   | <i>H3-02, H3-10, or H3-06</i> settings are enabled for the option card input terminal. The level of the set input signal must align with the polarity of the external signals.    |
|                         | MEMOBUS register 0004H   | <ul style="list-style-type: none"> <li><i>b1-01 = 2 [Frequency Reference Selection 1 = Memobus/Modbus Communications]</i></li> <li>When register bit 2 of 000FH = 1, the torque reference and torque limit from register 0004H is enabled.</li> </ul>       | -   |
|                         | Communication option card  | <ul style="list-style-type: none"> <li><i>b1-01 = 3 [Option PCB]</i></li> <li><i>F6-06 = 1 [Torque Reference/Limit by Comm = Enabled]</i></li> </ul> Refer to the communication option card manual for more information about the torque reference setting. | -   |
| Speed Limit             | Frequency Reference Selection (Reference source selected with b1-01) | <i>d5-03 = 1 [Speed Limit Selection = Active Frequency Reference]</i><br>The drive gets the speed limit from the frequency reference source input in <i>b1-01</i> or <i>b1-15 [Frequency Reference Selection 2]</i> . *1                                    | The drive applies the settings in <i>C1-01 to C1-08 [Acceleration/Deceleration Times]</i> and <i>C2-01 to C2-04 [S-Curve Time @ Start/End of Accel/Decel]</i> to the speed limit. |
|                         | <i>d5-04 [Speed Limit]</i>   | <i>d5-03 = 2 [d5-04 Setting]</i>  | -   |

| Configuration Parameter | Signal Input Method                     | Parameter Settings  | Notes   |
|-------------------------|---|---|---|
| Torque Compensation     | Drive analog input terminals A1, A2, A3 | $H3-02$ , $H3-10$ , or $H3-06 = 14$ [Torque Compensation] *1  | The level of the set input signal must align with the polarity of the external signals.   |
|                         | Analog reference option cards AI-A3     | <ul style="list-style-type: none"> <li><math>F2-01 = 0</math></li> <li><math>H3-02</math>, <math>H3-10</math>, or <math>H3-06 = 14</math> *1</li> </ul>                                   | $H3-02$ , $H3-10$ , or $H3-06$ settings are enabled for the option card input terminal. The level of the set input signal must align with the polarity of the external signals. |
|                         | MEMOBUS register 0005H                  | <ul style="list-style-type: none"> <li><math>b1-01 = 2</math></li> <li>When register bit 3 of 000FH = 1, the torque reference and torque limit from register 0005H is enabled.</li> </ul> | -   |
|                         | Communication option card               | $b1-01 = 3$<br>Refer to the communication option card manual for more information about the torque reference setting.   | -   |

\*1 Sets analog input terminals A1, A2, and A3 to supply the speed limit, torque reference, or torque compensation. If you set the same function to A1 to A3 terminals with  $H3-02$ ,  $H3-10$ , or  $H3-06$ , the drive will detect *oPE07* [Analog Input Selection Error].

### Input Signal Polarity

The positive and negative torque references set the motor rotation direction. The direction of the Run command does not set it. The positive and negative torque reference signals and the direction of the Run command have an effect on the internal torque reference.

**Table 2.39 Torque Control Signal Polarity**

| Run Command Direction | Torque Reference Signal Polarity | Direction of Motor Rotation | Polarity of the Internal Torque Reference [U1-09] |
|-----------------------|----------------------------------|-----------------------------|---|
| Forward run           | + (Positive)                     | Forward direction           | + (Positive)                                      |
|                       | - (Negative)                     | Reverse direction           | - (Negative)                                      |
| Reverse run           | + (Positive)                     | Reverse direction           | - (Negative)                                      |
|                       | - (Negative)                     | Forward direction           | + (Positive)                                      |

**Note:**

For Yaskawa motors, the forward run direction is counterclockwise direction when seen from the load shaft.

When you use analog inputs, you can get negative input values with these methods:

- Apply negative voltage input signals.
- Use positive voltage input signals and set the analog input bias to negative values.
- Apply positive voltage input signals and use a digital input programmed for *Analog TorqueRef Polarity Invert* [ $H1-xx = 78$ ].

When you use MEMOBUS/Modbus communication or a communication option card, set the positive or negative signed torque reference.

When the level of the analog signal input is 0 V to 10 V or 4 mA to 20 mA, the torque reference is the forward direction. To reverse the polarity of the torque reference, use one of these two methods:

- Use a -10 V to +10 V voltage input
- Set  $H1-xx = 78$  [*MFDI Function Select = Analog TorqueRef Polarity Invert*].

### ■ Speed Limit and Speed Limit Bias

The drive reads the speed limit setting from the input selected in  $d5-03$  [*Speed Limit Selection*]. You can use  $d5-05$  [*Speed Limit Bias*] to add a bias to this speed. Parameter  $d5-08$  [*Uni-directional Speed Limit Bias*] sets how the drive applies bias to the speed limit.

Table 2.40 shows the relation between these settings:

**Table 2.40 Speed Limit, Speed Bias and Speed Limit Priority Selection**

| Run command                | Operating Conditions |              |              |              |              |              |              |              |
|----------------------------|----------------------|--------------|--------------|--------------|--------------|--------------|--------------|--------------|
|                            | Forward              | Reverse      | Forward      | Reverse      | Forward      | Reverse      | Forward      | Reverse      |
| Torque reference direction | + (Positive)         | + (Positive) | - (Negative) | - (Negative) | - (Negative) | - (Negative) | + (Positive) | + (Positive) |

## 2.5 d: Softstarter

| Speed limit direction                         | Operating Conditions |              |              |              |              |              |              |              |
|---|----------------------|--------------|--------------|--------------|--------------|--------------|--------------|--------------|
|   | + (Positive)         | - (Negative) | - (Negative) | + (Positive) | + (Positive) | - (Negative) | - (Negative) | + (Positive) |
| Direction of motor rotation                   | Forward              |              | Reverse      |              | Forward      |              | Reverse      |              |
| Generated torque (d5-08 = 0 [Disabled])<br>*1 |                      |              |              |              |              |              |              |              |
| Generated torque (d5-08 = 1 [Enabled])<br>*1  |                      |              |              |              |              |              |              |              |
| Application example                           | Wind up              |              |              |              | Rewind       |              |              |              |
|   |                      |              |              |              |              |              |              |              |

\*1 The C5 parameter set the  $\Delta n$  value.

### ■ Show Speed Limit Operation

When the motor is at the speed limit or more than the speed limit, the drive sends a signal to the PLC or other such control devices to tell you that an error has occurred. To enable this function, set an MFDO function [H2-01 to H2-03] to 32 [In Speed Limit During Trq Ctrl].

### ■ Switch Between Torque Control and Speed Control

Use a digital input to switch Torque Control and Speed Control. To enable this function, set H1-xx = 71 [MFDI Function Select = Torque Control] to enable this function.

When you switch from Speed Control to Torque Control, the torque limit becomes the torque reference and the speed reference becomes the speed limit. When you switch from Torque Control to Speed Control, the torque reference becomes the torque limit and the speed limit becomes the speed reference. When you must use a delay time to switch between Speed Control and Torque Control, set d5-06 [Speed/Torque Changeover Time]. During this switch delay time, the drive keeps the reference value of the Torque Control and Speed Control when the switch signal was input. Change the reference values from an external control device during this delay time.

#### Note:

- When you switch between Torque Control and Speed Control, set d5-01 = 0 [Torque Control Selection = Speed Control]. If d5-01 = 1 [Torque Control] and H1-xx = 71 at the same time, the drive will detect oPE15 [Torque Control Setting Error].
- If the Stop command is input, the drive will not apply the delay time set in d5-06. Torque Control will immediately switch to Speed Control and ramp to stop.



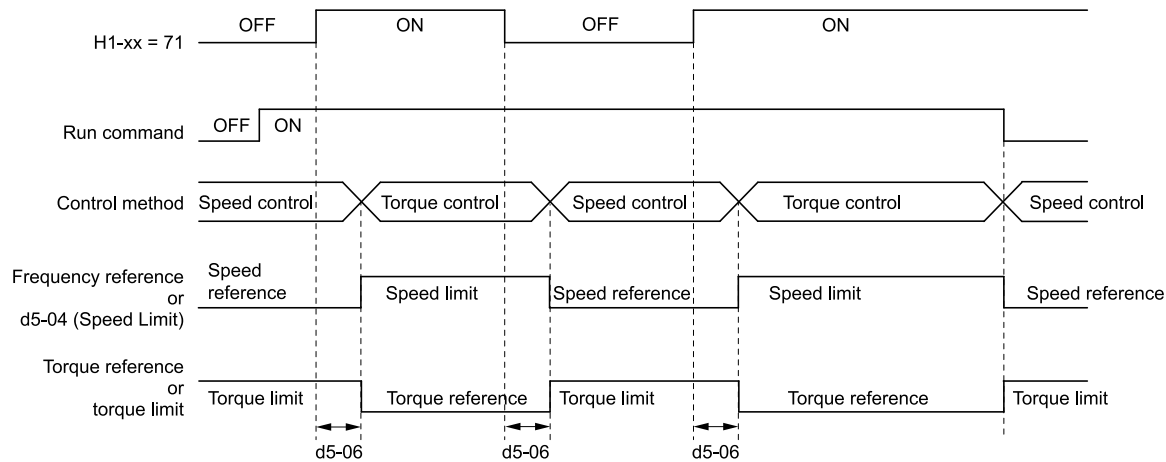


Figure 2.69 Speed/Torque Control Switching Time

### ■ d5-01: Torque Control Selection

| No. (Hex.)   | Name                     | Description  | Default (Range) |
|--------------|--------------------------|--|-----------------|
| d5-01 (029A) | Torque Control Selection | <input type="checkbox"/> V/f <input type="checkbox"/> CL-V/f <input type="checkbox"/> OLV <input checked="" type="checkbox"/> CLV <input type="checkbox"/> AOLV <input type="checkbox"/> OLV/PM <input type="checkbox"/> AOLV/PM <input type="checkbox"/> CLV/PM <input type="checkbox"/> EZOLV<br>Sets the drive for torque control or speed control. | 0<br>(0, 1)     |

#### 0 : Speed Control

Enables Speed Control. The drive controls the speed as specified by *C5-01 to C5-07 [Speed Control (ASR) Setting Parameters]*.

Also use this setting when you use *H1-xx = 71 [MFDI Function Select = Torque Control]* to change between Speed Control and Torque Control.

#### 1 : Torque Control

Always enables Torque Control.

### ■ d5-02: Torque Reference Delay Time

| No. (Hex.)   | Name                        | Description  | Default (Range)                      |
|--------------|-----------------------------|--|--------------------------------------|
| d5-02 (029B) | Torque Reference Delay Time | <input type="checkbox"/> V/f <input type="checkbox"/> CL-V/f <input type="checkbox"/> OLV <input checked="" type="checkbox"/> CLV <input type="checkbox"/> AOLV <input type="checkbox"/> OLV/PM <input type="checkbox"/> AOLV/PM <input type="checkbox"/> CLV/PM <input type="checkbox"/> EZOLV<br>Sets the primary delay time constant for the torque reference filter. | Determined by A1-02<br>(0 - 1000 ms) |

This parameter applies a primary delay filter to the torque reference signal to stop oscillation caused by a torque reference signal that is not stable. This also helps remove electrical interference from the torque reference signal and helps adjust the responsiveness between host controllers.

If oscillation occurs during Torque Control, increase the setting value. If the setting value is too high, responsiveness becomes unsatisfactory.

### ■ d5-03: Speed Limit Selection

| No. (Hex.)   | Name                  | Description  | Default (Range) |
|--------------|-----------------------|--|-----------------|
| d5-03 (029C) | Speed Limit Selection | <input type="checkbox"/> V/f <input type="checkbox"/> CL-V/f <input type="checkbox"/> OLV <input checked="" type="checkbox"/> CLV <input type="checkbox"/> AOLV <input type="checkbox"/> OLV/PM <input type="checkbox"/> AOLV/PM <input type="checkbox"/> CLV/PM <input type="checkbox"/> EZOLV<br>Sets the torque control speed limit method. | 1<br>(1, 2)     |

#### 1 : Active Frequency Reference

The enabled frequency reference set in *b1-01 [Frequency Reference Selection 1]* or *b1-15 [Frequency Reference Selection 2]* will be the speed limit. The drive applies the values set in *C1-01 to C1-08 [Acceleration/Deceleration Times 1 to 4]* and *C2-01 to C2-04 [S-Curve Time @ Start/End of Accel]* as speed limits.

#### 2 : d5-04 Setting

The speed limit is the value set in *d5-04*.

■ **d5-04: Speed Limit**

| No. (Hex.)   | Name        | Description  | Default (Range)      |
|--------------|-------------|--|----------------------|
| d5-04 (029D) | Speed Limit | <div style="display: flex; justify-content: space-between; font-size: 0.8em;"> <span>V/f</span> <span>CL-V/f</span> <span>OLV</span> <span style="background-color: #333; color: white; padding: 2px;">CLV</span> <span style="background-color: #333; color: white; padding: 2px;">AOLV</span> <span>OLV/PM</span> <span>AOLV/PM</span> <span>CLV/PM</span> <span>EZOLV</span> </div> <p>Sets the speed limit during Torque Control as a percentage of E1-04 [Maximum Output Frequency]. Set d5-03 = 2 [Speed Limit Selection = d5-04 Setting] before you set this parameter.</p> | 0%<br>(-120 - +120%) |

The speed limit is a positive value when it is in the same direction as the Run command. The speed limit is a negative value when it is in the opposite direction of the Run command.

■ **d5-05: Speed Limit Bias**

| No. (Hex.)   | Name             | Description  | Default (Range)   |
|--------------|------------------|--|-------------------|
| d5-05 (029E) | Speed Limit Bias | <div style="display: flex; justify-content: space-between; font-size: 0.8em;"> <span>V/f</span> <span>CL-V/f</span> <span>OLV</span> <span style="background-color: #333; color: white; padding: 2px;">CLV</span> <span style="background-color: #333; color: white; padding: 2px;">AOLV</span> <span>OLV/PM</span> <span>AOLV/PM</span> <span>CLV/PM</span> <span>EZOLV</span> </div> <p>Sets the speed limit bias value as a percentage of E1-04 [Maximum Output Frequency].</p> | 10%<br>(0 - 120%) |

Adjusts the margin for the speed limit.

■ **d5-06: Speed/Torque Changeover Time**

| No. (Hex.)   | Name                         | Description   | Default (Range)       |
|--------------|------------------------------|---|-----------------------|
| d5-06 (029F) | Speed/Torque Changeover Time | <div style="display: flex; justify-content: space-between; font-size: 0.8em;"> <span>V/f</span> <span>CL-V/f</span> <span>OLV</span> <span style="background-color: #333; color: white; padding: 2px;">CLV</span> <span style="background-color: #333; color: white; padding: 2px;">AOLV</span> <span>OLV/PM</span> <span>AOLV/PM</span> <span>CLV/PM</span> <span>EZOLV</span> </div> <p>Sets the delay time to switch between Speed Control and Torque Control. Set H1-xx = 71 [MFDI Function Select = Torque Control] before you set this parameter.</p> | 0 ms<br>(0 - 1000 ms) |

The analog input (torque reference, speed limit value) holds at the value when the drive switched between Speed and Torque Control in the time of the Speed/Torque Changeover Timer. During this time, prepare to switch to an external source.

■ **d5-08: Uni-directional Speed Limit Bias**

| No. (Hex.)   | Name                             | Description  | Default (Range) |
|--------------|----------------------------------|--|-----------------|
| d5-08 (02B5) | Uni-directional Speed Limit Bias | <div style="display: flex; justify-content: space-between; font-size: 0.8em;"> <span>V/f</span> <span>CL-V/f</span> <span>OLV</span> <span style="background-color: #333; color: white; padding: 2px;">CLV</span> <span style="background-color: #333; color: white; padding: 2px;">AOLV</span> <span>OLV/PM</span> <span>AOLV/PM</span> <span>CLV/PM</span> <span>EZOLV</span> </div> <p>Sets the direction of the speed limit reference to which Speed Limit Bias [d5-05] applies.</p> | 1<br>(0, 1)     |

**0 : Disabled**

The drive applies the speed limit bias in the speed limit direction and the opposite direction.

**1 : Enabled**

The drive applies the speed limit bias in the opposite direction of the speed limit only.

◆ **d6: Field Weakening /Forcing**

d6 parameters set the field weakening and field forcing functions.

The field weakening function decreases the energy consumption of the motor. It decreases the output voltage of the drive to a set level. The function decreases the motor excitation current inversely proportional to speed in a constant output range, and does not let the induced voltage of the motor become more than the power supply voltage. To enable this function, set *Field Weakening* [H1-xx = 63] ON.

**Note:**

Use the Field Weakening function in constant light-load applications. To control the energy consumption of the motor for other load conditions, use the b8 parameters [Energy Saving].

The Field Forcing function adjusts the delaying influence of the motor time constant when the drive changes the excitation current reference and it also increases motor responsiveness. This function uses a high motor excitation current reference for drive start-up only to help develop actual motor excitation current. Enable the Field Forcing function to increase motor responsiveness.

**Note:**

You cannot use Field Forcing during DC Injection Braking.

### ■ d6-01: Field Weakening Level

| No. (Hex.)      | Name                  | Description  | Default (Range)   |
|-----------------|-----------------------|--|-------------------|
| d6-01<br>(02A0) | Field Weakening Level | <div style="display: flex; justify-content: space-between; font-size: 0.8em; margin-bottom: 5px;"> <span>V/f</span> <span>CL-V/f</span> <span>OLV</span> <span>CLV</span> <span>AOLV</span> <span>OLV/PM</span> <span>AOLV/PM</span> <span>CLV/PM</span> <span>EZOLV</span> </div> Sets the drive output voltage as a percentage of <i>E1-05 [Maximum Output Voltage]</i> when <i>H1-xx = 63 [Field Weakening]</i> is activated. | 80%<br>(0 - 100%) |

### ■ d6-02: Field Weakening Frequency Limit

| No. (Hex.)      | Name                            | Description  | Default (Range)            |
|-----------------|---------------------------------|--|----------------------------|
| d6-02<br>(02A1) | Field Weakening Frequency Limit | <div style="display: flex; justify-content: space-between; font-size: 0.8em; margin-bottom: 5px;"> <span>V/f</span> <span>CL-V/f</span> <span>OLV</span> <span>CLV</span> <span>AOLV</span> <span>OLV/PM</span> <span>AOLV/PM</span> <span>CLV/PM</span> <span>EZOLV</span> </div> Sets the minimum output frequency to start field weakening. | 0.0 Hz<br>(0.0 - 590.0 Hz) |

Make sure that these two conditions are correct to enable the Field Weakening command:

- The output frequency  $\geq$  *d6-02*.
- There is a speed agreement status.

### ■ d6-03: Field Forcing Selection

| No. (Hex.)      | Name                    | Description   | Default (Range) |
|-----------------|-------------------------|---|-----------------|
| d6-03<br>(02A2) | Field Forcing Selection | <div style="display: flex; justify-content: space-between; font-size: 0.8em; margin-bottom: 5px;"> <span>V/f</span> <span>CL-V/f</span> <span>OLV</span> <span>CLV</span> <span>AOLV</span> <span>OLV/PM</span> <span>AOLV/PM</span> <span>CLV/PM</span> <span>EZOLV</span> </div> Sets the field forcing function. | 0<br>(0, 1)     |

**0 : Disabled**

**1 : Enabled**

### ■ d6-06: Field Forcing Limit

| No. (Hex.)      | Name                | Description  | Default (Range)      |
|-----------------|---------------------|--|----------------------|
| d6-06<br>(02A5) | Field Forcing Limit | <div style="display: flex; justify-content: space-between; font-size: 0.8em; margin-bottom: 5px;"> <span>V/f</span> <span>CL-V/f</span> <span>OLV</span> <span>CLV</span> <span>AOLV</span> <span>OLV/PM</span> <span>AOLV/PM</span> <span>CLV/PM</span> <span>EZOLV</span> </div> Sets the limit value for field forcing to increase the motor excitation current reference as a percentage of <i>E2-03 [Motor No-Load Current]</i> . Usually it is not necessary to change this setting. | 400%<br>(100 - 400%) |

**Note:**

You cannot use Field Forcing during DC Injection Braking.

### ◆ d7: Offset Frequency

The drive will use 3 digital signal inputs, to add or subtract the set frequency (Offset frequency) to/from the frequency reference and correct the speed. The drive uses the terminal set in *H1-xx = 44 to 46 [MFDI Function Select = Add Offset Frequency 1 to 3]* to set the Offset frequency. When you close more than one input at the same time, the drive adds the selected offset values together.

Figure 2.70 shows the Offset frequency function:

## 2.5 d: Softstarter

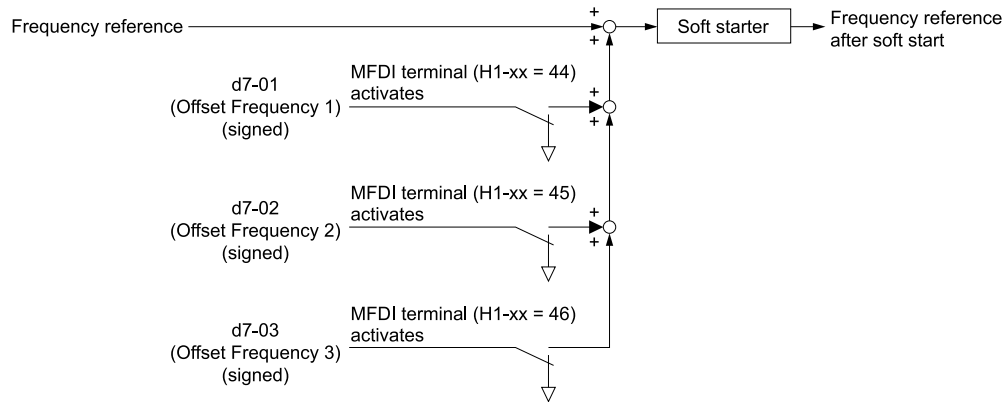


Figure 2.70 Offset Frequency Operation

### ■ d7-01: Offset Frequency 1

| No. (Hex.)             | Name               | Description   | Default (Range)            |
|------------------------|--------------------|---|----------------------------|
| d7-01<br>(02B2)<br>RUN | Offset Frequency 1 | <b>V/f</b> <b>CL-V/f</b> <b>OLV</b> <b>CLV</b> <b>AOLV</b> <b>OLV/PM</b> <b>AOLV/PM</b> <b>CLV/PM</b> <b>EZOLV</b><br>Adds or subtracts the set frequency to/from the frequency reference using $H1-xx = 44$ [MFDI Function Select = Add Offset Frequency 1 (d7-01)] as a percentage of the Maximum Output Frequency. | 0.0%<br>(-100.0 - +100.0%) |

### ■ d7-02: Offset Frequency 2

| No. (Hex.)             | Name               | Description   | Default (Range)            |
|------------------------|--------------------|---|----------------------------|
| d7-02<br>(02B3)<br>RUN | Offset Frequency 2 | <b>V/f</b> <b>CL-V/f</b> <b>OLV</b> <b>CLV</b> <b>AOLV</b> <b>OLV/PM</b> <b>AOLV/PM</b> <b>CLV/PM</b> <b>EZOLV</b><br>Adds or subtracts the set frequency to/from the frequency reference using $H1-xx = 45$ [MFDI Function Select = Add Offset Frequency 2 (d7-02)] as a percentage of the Maximum Output Frequency. | 0.0%<br>(-100.0 - +100.0%) |

### ■ d7-03: Offset Frequency 3

| No. (Hex.)             | Name               | Description   | Default (Range)            |
|------------------------|--------------------|---|----------------------------|
| d7-03<br>(02B4)<br>RUN | Offset Frequency 3 | <b>V/f</b> <b>CL-V/f</b> <b>OLV</b> <b>CLV</b> <b>AOLV</b> <b>OLV/PM</b> <b>AOLV/PM</b> <b>CLV/PM</b> <b>EZOLV</b><br>Adds or subtracts the set frequency to/from the frequency reference using $H1-xx = 46$ [MFDI Function Select = Add Offset Frequency 3 (d7-03)] as a percentage of the Maximum Output Frequency. | 0.0%<br>(-100.0 - +100.0%) |

## 2.6 E: Motor Parameters

*E* parameters cover drive input voltage, V/f pattern, and motor parameters.

### ◆ E1: V/f Pattern for Motor 1

*E1* parameters are used to set the drive input voltage and motor V/f characteristics. To switch drive operation from one motor to another motor, set the V/f characteristics for motor 1.

#### ■ V/f Pattern Settings

The drive uses a V/f pattern to adjust the output voltage relative to the frequency reference.

This product has been preconfigured with 15 voltage/frequency (V/f) patterns. Use *E1-03 [V/f Pattern Selection]* to select the V/f pattern that is appropriate for the application.

Additionally, one custom V/f pattern is available. Set *E1-03 = F [Custom]* and then manually set parameters *E1-04* to *E1-10*.

**Table 2.41 Predefined V/f Patterns**

| Setting Value | Specification                     | Characteristic                 | Application   |
|---------------|-----------------------------------|--------------------------------|---|
| 0             | Const Trq, 50Hz base, 50Hz max    | Constant torque                | For general purpose applications. This pattern is used when the load torque is constant without any rotation speed such as that used for linear conveyor systems.   |
| 1             | Const Trq, 60Hz base, 60Hz max    |                                |   |
| 2             | Const Trq, 50Hz base, 60Hz max    |                                |   |
| 3             | Const Trq, 60 Hz base, 72 Hz max  |                                |   |
| 4             | VT, 50Hz, 65% Vmid reduction      | Derated torque characteristics | This pattern is used for torque loads proportional to 2 or 3 times the rotation speed, such as is the case with fans and pumps.   |
| 5             | VT, 50Hz, 50% Vmid reduction      |                                |   |
| 6             | VT, 60Hz, 65% Vmid reduction      |                                |   |
| 7             | VT, 60Hz, 50% Vmid reduction      |                                |   |
| 8             | High Trq, 50Hz, 25% Vmin boost    | High starting torque           | This pattern is used when strong torque is required during startup.   |
| 9             | High Trq, 50Hz, 65% Vmin boost    |                                |   |
| A             | High Trq, 60Hz, 25% Vmin boost    |                                |   |
| B             | High Trq, 60Hz, 65% Vmin boost    |                                |   |
| C             | Const Trq, 60 Hz base, 90 Hz max  | Constant output                | This pattern is used to rotate motors at greater than 60 Hz. Output voltage is constant when operating at greater than 60 Hz.   |
| D             | Const Trq, 60 Hz base, 120 Hz max |                                |   |
| E             | Const Trq, 60 Hz base, 180 Hz max |                                |   |
| F             | Const Trq, 60Hz base, 60Hz max    | Constant torque                | Enables a custom V/f pattern by changing <i>E1-04</i> to <i>E1-13 [V/f Pattern for Motor 1]</i> . The default settings for <i>E1-04</i> to <i>E1-13</i> are the same as <i>Setting Value 1 [Const Trq, 60Hz base, 60Hz max]</i> . |

## 2.6 E: Motor Parameters

### Note:

Be aware of the following points when manually setting V/f patterns.

- To set linear V/f characteristics at frequencies lower than that of  $E1-06$  [Base Frequency], set  $E1-07 = E1-09$  [Mid Point A Frequency = Minimum Output Frequency]. In this application, the drive ignores  $E1-08$  [Mid Point A Voltage].
- Set the five frequencies as specified by these rules: Incorrect settings will trigger  $oPE10$  [V/f Data Setting Error].  
 $E1-09 \leq E1-07 < E1-06 \leq E1-11 \leq E1-04$  [Minimum Output Frequency  $\leq$  Mid Point A Frequency  $<$  Base Frequency  $\leq$  Mid Point B Frequency  $\leq$  Maximum Output Frequency]
- Setting  $E1-11 = 0$  [Mid Point B Frequency = 0 Hz] disables  $E1-12$  [Mid Point B Voltage]. Ensure that the four frequencies are set according to the following rules;  
 $E1-09 \leq E1-07 < E1-06 \leq E1-04$
- Parameter  $E1-03$  is not reset when the drive is initialized using  $A1-03$  [Initialize].

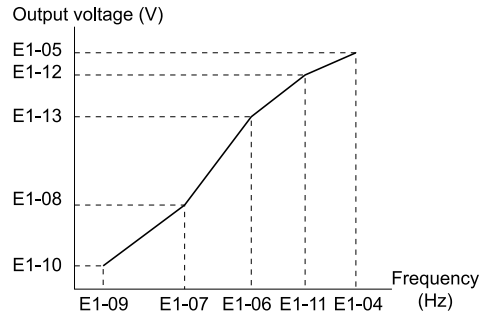


Figure 2.71 V/f Pattern

### ■ E1-01: Input AC Supply Voltage

| No. (Hex.)   | Name                    | Description  | Default (Range)  |
|--------------|-------------------------|--|--|
| E1-01 (0300) | Input AC Supply Voltage | <input checked="" type="checkbox"/> V/f <input checked="" type="checkbox"/> CL-V/f <input checked="" type="checkbox"/> OLV <input checked="" type="checkbox"/> CLV <input checked="" type="checkbox"/> AOLV <input checked="" type="checkbox"/> OLV/PM <input checked="" type="checkbox"/> AOLV/PM <input checked="" type="checkbox"/> CLV/PM <input checked="" type="checkbox"/> EZOLV<br>Sets the drive input voltage. | 200 V Class: 240 V, 400 V: 480 V<br>(200 V Class: 155 to 255 V, 400 V Class: 310 to 510 V) |

**NOTICE:** Set parameter  $E1-01$  to align with the drive input voltage (not motor voltage). If this parameter is incorrect, the protective functions of the drive will not operate correctly and it can cause damage to the drive.

#### Values Related to the Drive Input Voltage

The value set in  $E1-01$  is the base value used for the motor protective functions in Table 2.42. With a 400 V class drive, the detection level changes for some motor protective functions.

Table 2.42 Values Related to the Drive Input Voltage

| Voltage     | E1-01 setting              | Approximate Values |   |  |                                     |                                 |
|-------------|----------------------------|--------------------|---|--|-------------------------------------|---------------------------------|
|             |                            | ov Detection Level | BTR Operation Level (rr Detection Level) *1 | L2-05 [Undervoltage Detection Lvl (Uv1)] | L2-11 [KEB DC Bus Voltage Setpoint] | L3-17 [DC Bus Regulation Level] |
| 200 V class | All settings               | 410 V              | 394 V                                       | 190 V                                    | 260 V                               | 375 V                           |
| 400 V class | Setting value $\geq$ 400 V | 820 V              | 788 V                                       | 380 V                                    | 500 V                               | 750 V                           |
|             | Setting value $<$ 400 V    | 820 V              | 788 V                                       | 350 V                                    | 460 V                               | 750 V                           |

\*1 This is the protection function enabled in drives with built-in braking transistors. These values show the level that will trigger the built-in braking transistor. Refer to "YASKAWA AC Drive 72060001 Series Option Braking Unit and Braking Resistor Unit Installation Manual (TOBPC72060001)" for more information.

### ■ E1-03: V/f Pattern Selection

| No. (Hex.)   | Name                  | Description   | Default (Range)            |
|--------------|-----------------------|---|----------------------------|
| E1-03 (0302) | V/f Pattern Selection | <input checked="" type="checkbox"/> V/f <input checked="" type="checkbox"/> CL-V/f <input checked="" type="checkbox"/> OLV <input checked="" type="checkbox"/> CLV <input checked="" type="checkbox"/> AOLV <input checked="" type="checkbox"/> OLV/PM <input checked="" type="checkbox"/> AOLV/PM <input checked="" type="checkbox"/> CLV/PM <input checked="" type="checkbox"/> EZOLV<br>Sets the V/f pattern for the drive and motor. You can use one of the preset patterns or you can make a custom pattern. | F<br>(Determined by A1-02) |

**Note:**

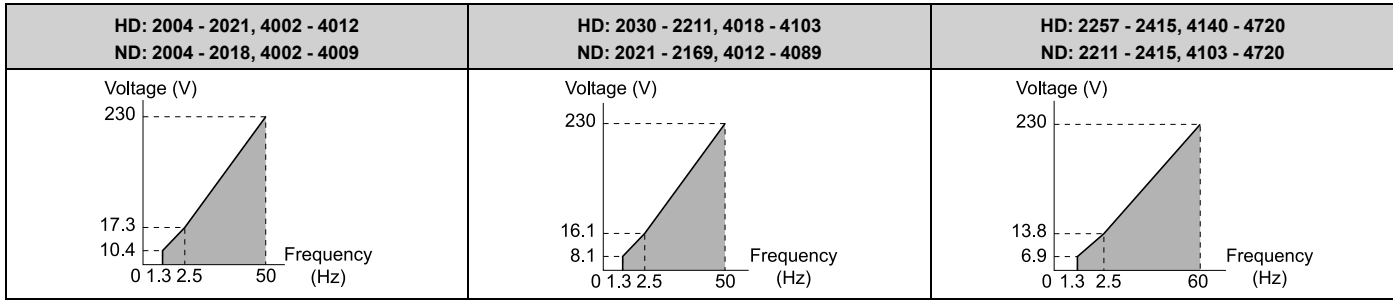
- When  $A1-02 = 2$  [Control Method Selection = OLV], settings 0 through E are not available.
- Set the correct V/f pattern for the application and operation area. An incorrect V/f pattern can decrease motor torque and increase current from overexcitation.
- Parameter  $A1-03$  [Initialize Parameters] will not initialize the value  $E1-03$ .

**0 : Const Trq, 60Hz base, 60Hz max**

Use this constant torque pattern for general applications. This pattern is used when the load torque is constant without any rotation speed such as that used for linear conveyor systems.

**Note:**

The voltage values in the figures are for 200 V class drives. Multiply the values by 2 for 400 V class drives.

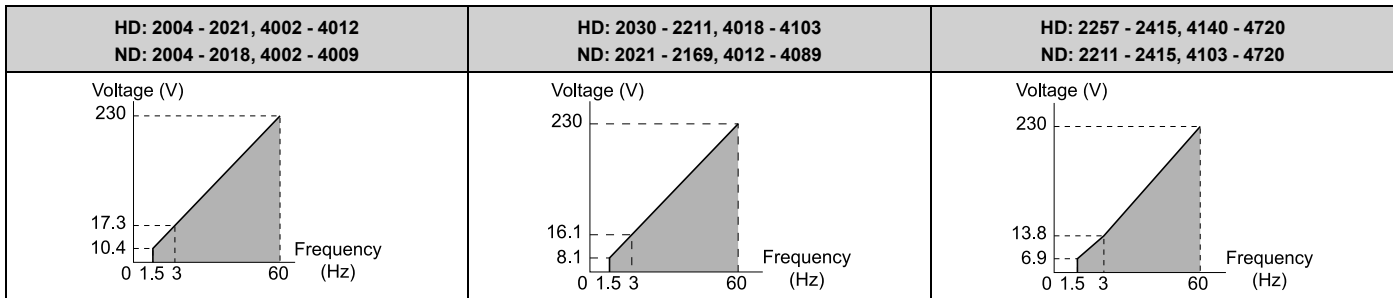


**1 : Const Trq, 60Hz base, 60Hz max**

Use this constant torque pattern for general applications. This pattern is used when the load torque is constant without any rotation speed such as that used for linear conveyor systems.

**Note:**

The voltage values in the figures are for 200 V class drives. Multiply the values by 2 for 400 V class drives.

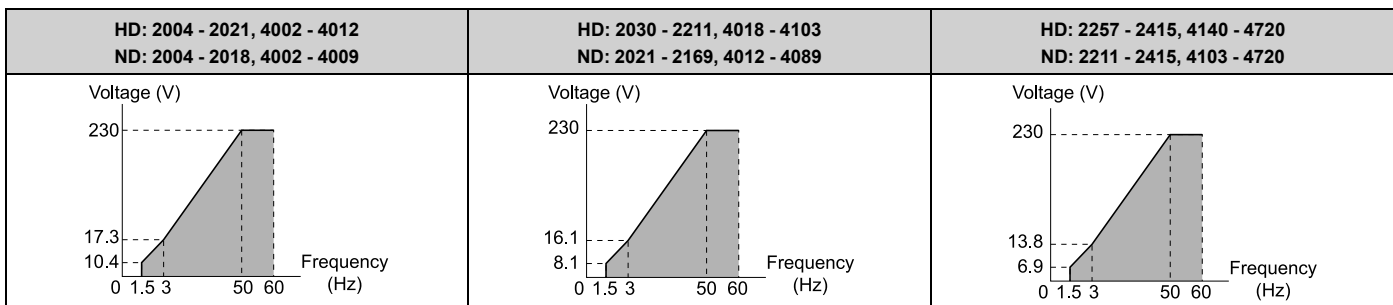


**2 : Const Trq, 50Hz base, 60Hz max**

Use this constant torque pattern for general applications. This pattern is used when the load torque is constant without any rotation speed such as that used for linear conveyor systems.

**Note:**

The voltage values in the figures are for 200 V class drives. Multiply the values by 2 for 400 V class drives.



**3 : Const Trq, 60 Hz base, 72 Hz max**

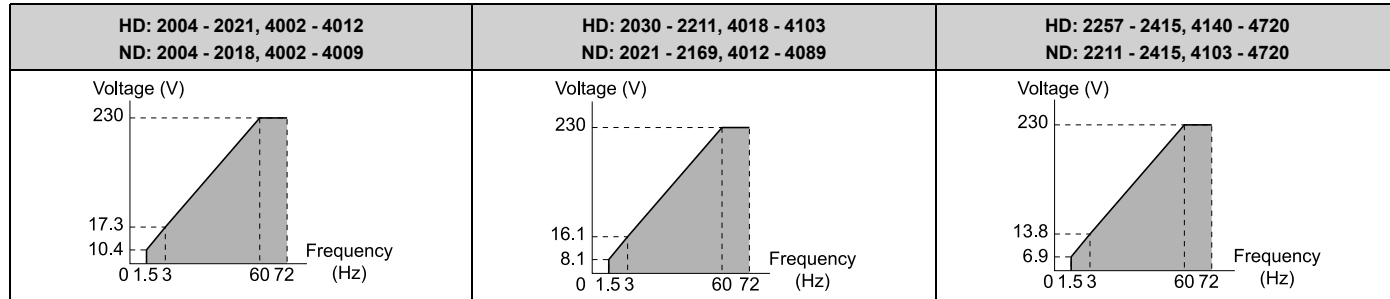
Parameter Details

## 2.6 E: Motor Parameters

Use this constant torque pattern for general applications. This pattern is used when the load torque is constant without any rotation speed such as that used for linear conveyor systems.

**Note:**

The voltage values in the figures are for 200 V class drives. Multiply the values by 2 for 400 V class drives.

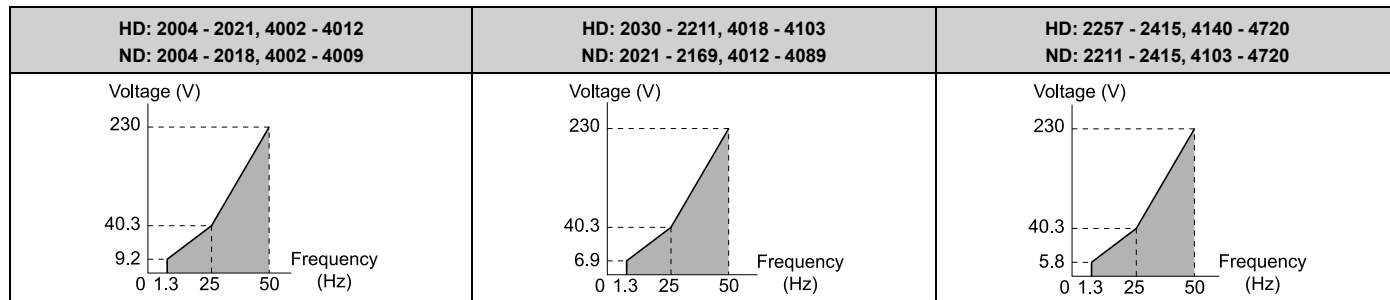


### 4 : VT, 50Hz, 65% Vmid reduction

Use this derated torque pattern for torque loads proportional to three times the rotation speed. For example, fans and pumps.

**Note:**

The voltage values in the figures are for 200 V class drives. Multiply the values by 2 for 400 V class drives.

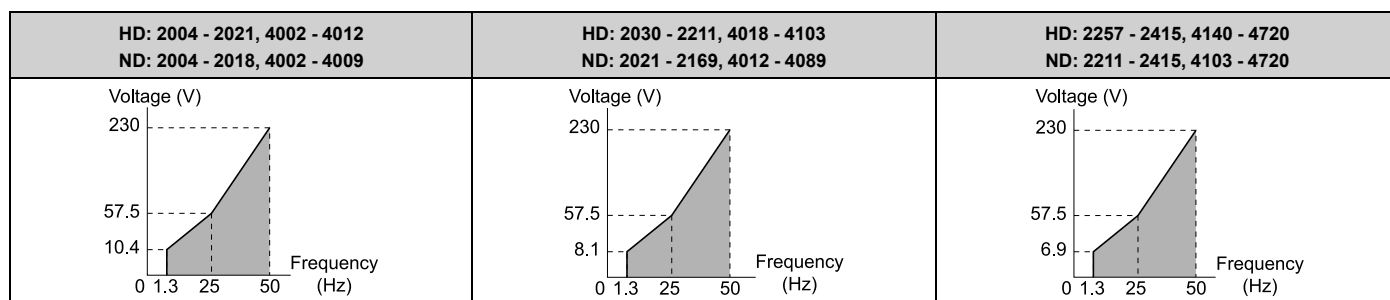


### 5 : VT, 50Hz, 50% Vmid reduction

Use this derated torque pattern for torque loads proportional to two times the rotation speed. For example, fans and pumps.

**Note:**

The voltage values in the figures are for 200 V class drives. Multiply the values by 2 for 400 V class drives.



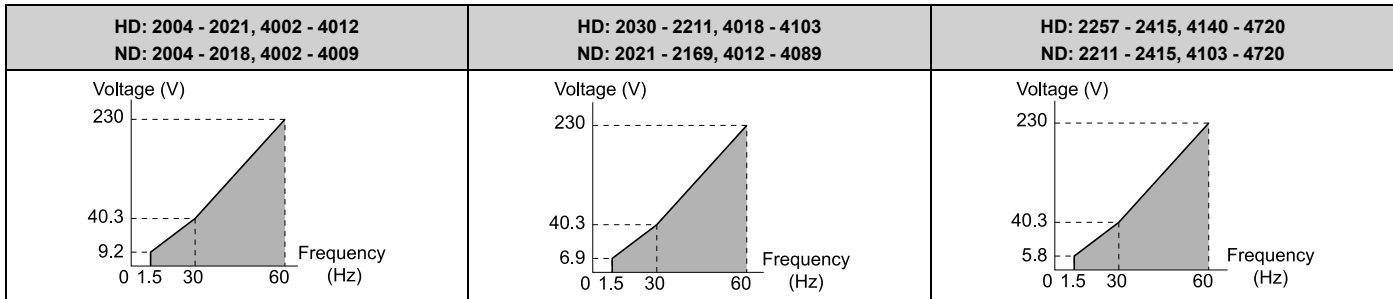
### 6 : VT, 60 Hz, 65% Vmid reduction

Use this derated torque pattern for torque loads proportional to three times the rotation speed. For example, fans and pumps.

**Note:**

The voltage values in the figures are for 200 V class drives. Multiply the values by 2 for 400 V class drives.



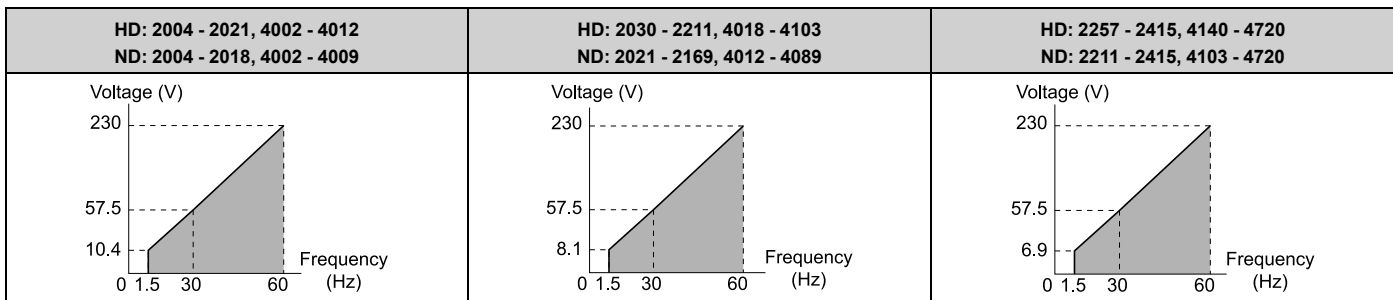


**7 : VT, 60Hz, 50% Vmid reduction**

Use this derated torque pattern for torque loads proportional to two times the rotation speed. For example, fans and pumps.

**Note:**

The voltage values in the figures are for 200 V class drives. Multiply the values by 2 for 400 V class drives.



**8 : High Trq, 50Hz, 25% Vmin boost**

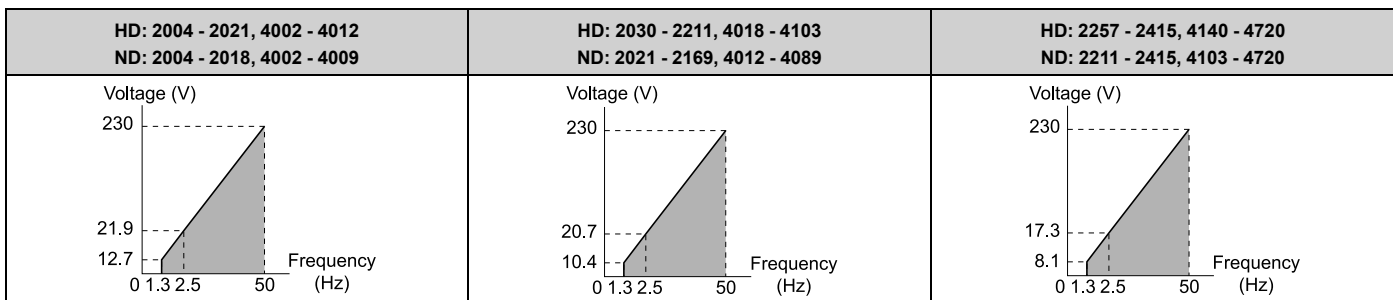
Use this pattern when moderate torque is necessary during start up.

Select this pattern only in these conditions:

- The wiring distance between the drive and motor is 150 m (492.1 ft.) minimum.
- There is an AC reactor connected to the drive output.

**Note:**

The voltage values in the figures are for 200 V class drives. Multiply the values by 2 for 400 V class drives.



**9 : High Trq, 50Hz, 65% Vmin boost**

Use this pattern when high torque is necessary during start up.

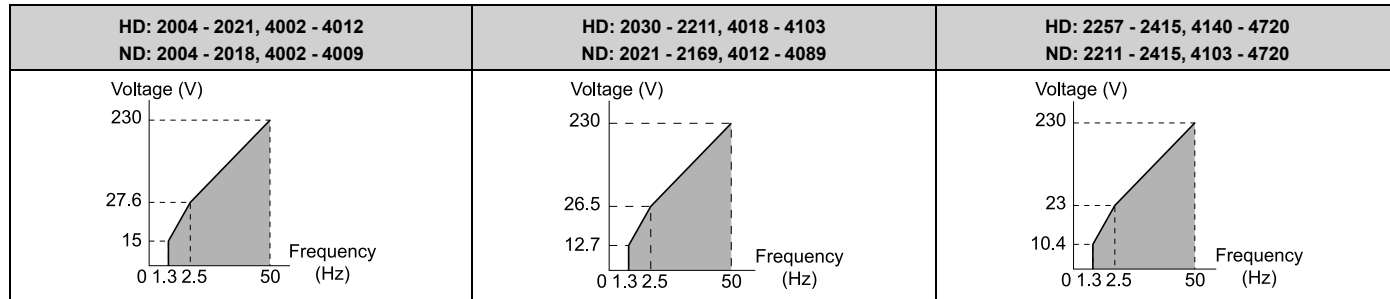
Select this pattern only in these conditions:

- The wiring distance between the drive and motor is 150 m (492.1 ft.) minimum.
- There is an AC reactor connected to the drive output.

**Note:**

The voltage values in the figures are for 200 V class drives. Multiply the values by 2 for 400 V class drives.

## 2.6 E: Motor Parameters



### A : High Trq, 60Hz, 25% Vmin boost

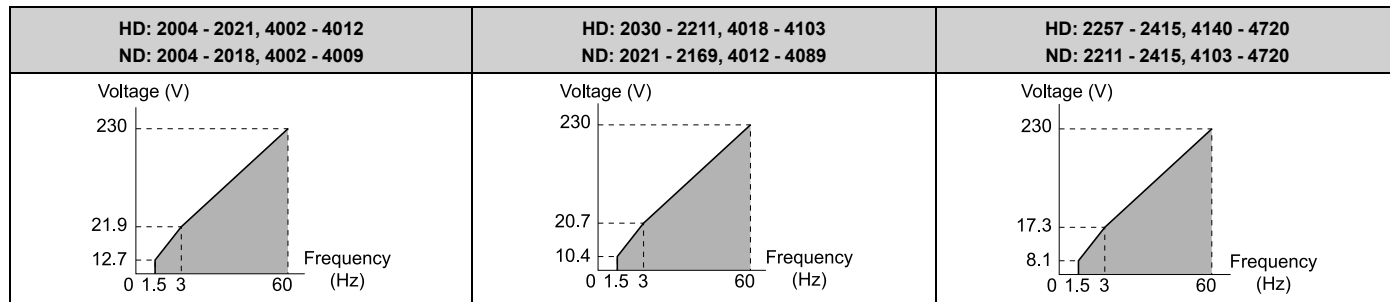
Use this pattern when moderate torque is necessary during start up.

Select this pattern only in these conditions:

- The wiring distance between the drive and motor is 150 m (492.1 ft.) minimum.
- There is an AC reactor connected to the drive output.

**Note:**

The voltage values in the figures are for 200 V class drives. Multiply the values by 2 for 400 V class drives.



### B : High Trq, 60Hz, 65% Vmin boost

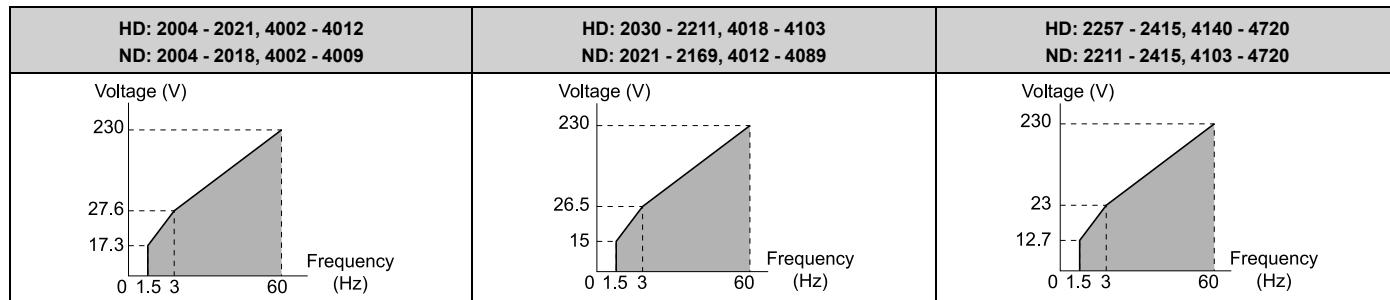
Use this pattern when high torque is necessary during start up.

Select this pattern only in these conditions:

- The wiring distance between the drive and motor is 150 m (492.1 ft.) minimum.
- There is an AC reactor connected to the drive output.

**Note:**

The voltage values in the figures are for 200 V class drives. Multiply the values by 2 for 400 V class drives.

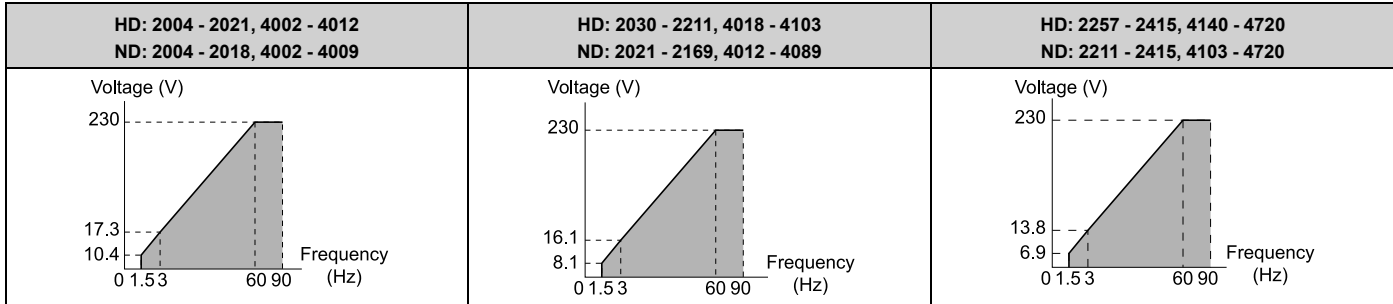


### C : Const Trq, 60 Hz base, 90 Hz max

Use this constant output pattern to rotate motors at more than 60 Hz. Output voltage is constant when you operate at more than 60 Hz.

**Note:**

The voltage values in the figures are for 200 V class drives. Multiply the values by 2 for 400 V class drives.

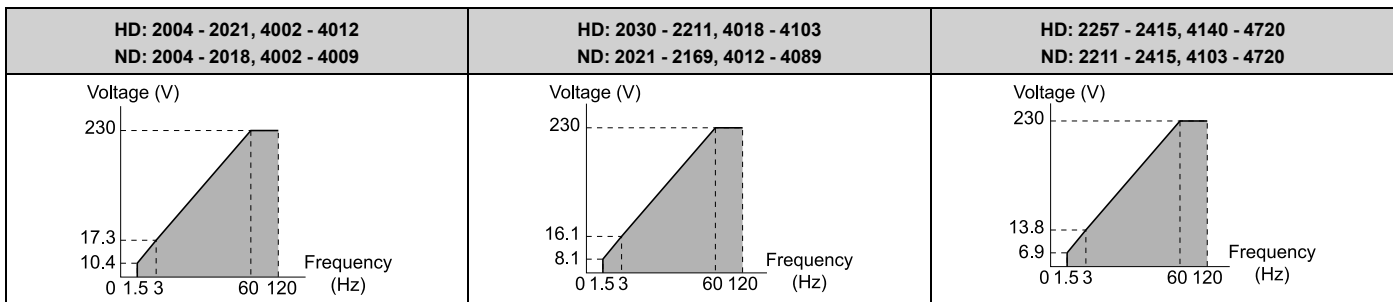


**D : Const Trq, 60 Hz base, 120 Hz max**

Use this constant output pattern to rotate motors at more than 60 Hz. Output voltage is constant when you operate at more than 60 Hz.

**Note:**

The voltage values in the figures are for 200 V class drives. Multiply the values by 2 for 400 V class drives.

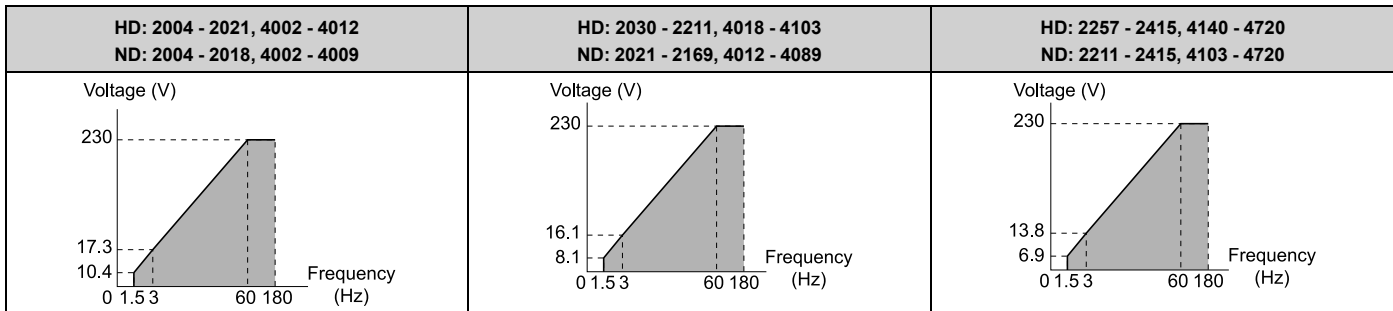


**E : Const Trq, 60 Hz base, 180 Hz max**

Use this constant output pattern to rotate motors at more than 60 Hz. Output voltage is constant when you operate at more than 60 Hz.

**Note:**

The voltage values in the figures are for 200 V class drives. Multiply the values by 2 for 400 V class drives.



**F : User-defined V/f pattern**

Set E1-04 to E1-13 [V/f Pattern for Motor 1] to set the values for this custom pattern.

The default settings are the same as Setting Value 1 [Const Trq, 60Hz base, 60Hz max].

■ **E1-04: Maximum Output Frequency**

| No. (Hex.)   | Name                     | Description  | Default (Range)   |
|--------------|--------------------------|--|---|
| E1-04 (0303) | Maximum Output Frequency | <input checked="" type="checkbox"/> V/f <input type="checkbox"/> CL-V/f <input type="checkbox"/> OLV <input type="checkbox"/> CLV <input type="checkbox"/> AOLV <input type="checkbox"/> OLV/IPM <input type="checkbox"/> AOLV/IPM <input type="checkbox"/> CLV/IPM <input type="checkbox"/> EZOLV | Determined by A1-02 and E5-01 (Determined by A1-02 and E5-01) |

Parameter Details

## 2.6 E: Motor Parameters

### ■ E1-05: Maximum Output Voltage

| No. (Hex.)      | Name                   | Description  | Default (Range)  |
|-----------------|------------------------|--|--|
| E1-05<br>(0304) | Maximum Output Voltage | <span>V/f</span> <span>CL-V/f</span> <span>OLV</span> <span>CLV</span> <span>AOLV</span> <span>OLV/PM</span> <span>AOLV/PM</span> <span>CLV/PM</span> <span>EZOLV</span><br>Sets the maximum output voltage for the V/f pattern. | 200 V Class: 230.0 V, 400 V:<br>460.0 V<br>(200 V Class: 0.0 - 255.0 V,<br>400 V Class: 0.0 - 510.0 V) |

### ■ E1-06: Base Frequency

| No. (Hex.)      | Name           | Description  | Default (Range)                                   |
|-----------------|----------------|--|---|
| E1-06<br>(0305) | Base Frequency | <span>V/f</span> <span>CL-V/f</span> <span>OLV</span> <span>CLV</span> <span>AOLV</span> <span>OLV/PM</span> <span>AOLV/PM</span> <span>CLV/PM</span> <span>EZOLV</span><br>Sets the base frequency for the V/f pattern. | Determined by A1-02 and<br>E5-01<br>(0.0 - E1-04) |

### ■ E1-07: Mid Point A Frequency

| No. (Hex.)      | Name                  | Description   | Default (Range)                      |
|-----------------|-----------------------|---|--------------------------------------|
| E1-07<br>(0306) | Mid Point A Frequency | <span>V/f</span> <span>CL-V/f</span> <span>OLV</span> <span>CLV</span> <span>AOLV</span> <span>OLV/PM</span> <span>AOLV/PM</span> <span>CLV/PM</span> <span>EZOLV</span><br>Sets a middle output frequency for the V/f pattern. | Determined by A1-02<br>(0.0 - E1-04) |

### ■ E1-08: Mid Point A Voltage

| No. (Hex.)      | Name                | Description   | Default (Range)   |
|-----------------|---------------------|---|---|
| E1-08<br>(0307) | Mid Point A Voltage | <span>V/f</span> <span>CL-V/f</span> <span>OLV</span> <span>CLV</span> <span>AOLV</span> <span>OLV/PM</span> <span>AOLV/PM</span> <span>CLV/PM</span> <span>EZOLV</span><br>Sets a middle output voltage for the V/f pattern. | Determined by A1-02, C6-<br>01 and o2-04<br>(200 V Class: 0.0 - 255.0 V,<br>400 V Class: 0.0 - 510.0 V) |

**Note:**

Default setting is determined by A1-02 [Control Method Selection], C6-01 [Normal / Heavy Duty Selection], and o2-04 [Drive Model Selection].

### ■ E1-09: Minimum Output Frequency

| No. (Hex.)      | Name                     | Description  | Default (Range)   |
|-----------------|--------------------------|--|---|
| E1-09<br>(0308) | Minimum Output Frequency | <span>V/f</span> <span>CL-V/f</span> <span>OLV</span> <span>CLV</span> <span>AOLV</span> <span>OLV/PM</span> <span>AOLV/PM</span> <span>CLV/PM</span> <span>EZOLV</span><br>Sets the minimum output frequency for the V/f pattern. | Determined by A1-02 and<br>E5-01<br>(Determined by A1-02, E1-<br>04, and E5-01) |

### ■ E1-10: Minimum Output Voltage

| No. (Hex.)      | Name                   | Description  | Default (Range)  |
|-----------------|------------------------|--|--|
| E1-10<br>(0309) | Minimum Output Voltage | <span>V/f</span> <span>CL-V/f</span> <span>OLV</span> <span>CLV</span> <span>AOLV</span> <span>OLV/PM</span> <span>AOLV/PM</span> <span>CLV/PM</span> <span>EZOLV</span><br>Sets the minimum output voltage for the V/f pattern. | Determined by A1-02<br>(200 V Class: 0.0 to 255.0 V,<br>400 V Class: 0.0 to 510.0 V) |

### ■ E1-11: Mid Point B Frequency

| No. (Hex.)                | Name                  | Description   | Default (Range)         |
|---------------------------|-----------------------|---|-------------------------|
| E1-11<br>(030A)<br>Expert | Mid Point B Frequency | <span>V/f</span> <span>CL-V/f</span> <span>OLV</span> <span>CLV</span> <span>AOLV</span> <span>OLV/PM</span> <span>AOLV/PM</span> <span>CLV/PM</span> <span>EZOLV</span><br>Sets a middle output frequency for the V/f pattern. | 0.0 Hz<br>(0.0 - E1-04) |

**Note:**

Set this parameter to 0.0 to disable the function.

### ■ E1-12: Mid Point B Voltage

| No. (Hex.)                | Name                | Description  | Default (Range)  |
|---------------------------|---------------------|--|--|
| E1-12<br>(030B)<br>Expert | Mid Point B Voltage | <b>V/f</b> <b>CL-V/f</b> <b>OLV</b> <b>CLV</b> <b>AOLV</b> <b>OLV/PM</b> <b>AOLV/PM</b> <b>CLV/PM</b> <b>EZOLV</b><br>Sets a middle point voltage for the V/f pattern. | 0.0 V<br>(200 V Class: 0.0 to 255.0 V,<br>400 V Class: 0.0 to 510.0 V) |

**Note:**

Set this parameter to 0.0 to disable the function.

### ■ E1-13: Base Voltage

| No. (Hex.)                | Name         | Description  | Default (Range)  |
|---------------------------|--------------|--|--|
| E1-13<br>(030C)<br>Expert | Base Voltage | <b>V/f</b> <b>CL-V/f</b> <b>OLV</b> <b>CLV</b> <b>AOLV</b> <b>OLV/PM</b> <b>AOLV/PM</b> <b>CLV/PM</b> <b>EZOLV</b><br>Sets the base voltage for the V/f pattern. | 0.0 V<br>(200 V Class: 0.0 - 255.0 V,<br>400 V Class: 0.0 - 510.0 V) |

**Note:**

- The setting value of  $E1-13 = E1-05$  [Maximum Output Voltage] after you do Auto-Tuning.
- When  $E1-13 = 0.0$ , use the value of  $E1-05$  to control the voltage.

## ◆ E2: Motor Parameters

*E2 parameters* [Motor Parameters] are used to set induction motor data. To switch drive operation from one motor to another motor, configure the first motor (motor 1).

Performing Auto-Tuning automatically sets the *E2 parameters* to the optimal values. If Auto-Tuning cannot be performed, set the *E2 parameters* manually.

**Note:**

If  $A1-02$  [Control Method Selection] is set to the following control modes, the keypad does not display  $E2-xx$ .

- 5 [PM Open Loop Vector]
- 6 [PM Advanced Open Loop Vector]
- 7 [PM Closed Loop Vector]
- 8 [EZ Vector Control]

### ■ E2-01: Motor Rated Current (FLA)

| No. (Hex.)      | Name                      | Description   | Default (Range)  |
|-----------------|---------------------------|---|--|
| E2-01<br>(030E) | Motor Rated Current (FLA) | <b>V/f</b> <b>CL-V/f</b> <b>OLV</b> <b>CLV</b> <b>AOLV</b> <b>OLV/PM</b> <b>AOLV/PM</b> <b>CLV/PM</b> <b>EZOLV</b><br>Sets the motor rated current in amps. | Determined by o2-04, C6-01<br>(10% to 200% of the drive rated current) |

**Note:**

- If  $E2-01 < E2-03$  [Motor No-Load Current] the drive will detect oPE02 [Parameter Range Setting Error].
- The default settings and setting ranges are in these units:  
–0.01 A: 2004 to 2042, 4002 to 4023  
–0.1 A: 2056 to 2415, 4031 to 4720

The value set for  $E2-01$  becomes the reference value for motor protection, the torque limit, and torque control. Enter the motor rated current as written on the motor nameplate. The value of  $E2-01$  is automatically set to the value input for “Motor Rated Current” by the Auto-Tuning process.

### ■ E2-02: Motor Rated Slip

| No. (Hex.)      | Name             | Description  | Default (Range)                                   |
|-----------------|------------------|--|---|
| E2-02<br>(030F) | Motor Rated Slip | <b>V/f</b> <b>CL-V/f</b> <b>OLV</b> <b>CLV</b> <b>AOLV</b> <b>OLV/PM</b> <b>AOLV/PM</b> <b>CLV/PM</b> <b>EZOLV</b><br>Sets motor rated slip. | Determined by o2-04, C6-01<br>(0.000 - 20.000 Hz) |

## 2.6 E: Motor Parameters

This parameter value becomes the base slip compensation value. The drive automatically sets this parameter during Auto-Tuning. When you cannot do Auto-Tuning, calculate the motor rated slip with the information on the motor nameplate and this formula:

$$E2-02 = f - (n \times p) / 120$$

- f: Motor rated frequency (Hz)
- n: Rated motor speed ( $\text{min}^{-1}$  (r/min))
- p: Number of motor poles

### ■ E2-03: Motor No-Load Current

| No. (Hex.)   | Name                  | Description  | Default (Range)                         |
|--------------|-----------------------|--|---|
| E2-03 (0310) | Motor No-Load Current | <div style="display: flex; gap: 5px;"> <span>V/f</span> <span>CL-V/f</span> <span>OLV</span> <span>CLV</span> <span>AOLV</span> <span>OLV/PM</span> <span>AOLV/PM</span> <span>CLV/PM</span> <span>EZOLV</span> </div> Sets the no-load current for the motor in amps when operating at the rated frequency and the no-load voltage. | Determined by o2-04, C6-01 (0 to E2-01) |

**Note:**

The default settings and setting ranges are in these units:

- 0.01 A: 2004 to 2042, 4002 to 4023
- 0.1 A: 2056 to 2415, 4031 to 4720

The drive automatically sets this parameter during Auto-Tuning. When you cannot do Auto-Tuning, you can also use the motor no-load current on the motor test report to enter this value manually. Contact the motor manufacturer to receive a copy of the motor test report.

**Note:**

The default setting of the no-load current is for operation with a 4-pole motor recommended by Yaskawa.

### ■ E2-04: Motor Pole Count

| No. (Hex.)   | Name             | Description  | Default (Range) |
|--------------|------------------|--|-----------------|
| E2-04 (0311) | Motor Pole Count | <div style="display: flex; gap: 5px;"> <span>V/f</span> <span>CL-V/f</span> <span>OLV</span> <span>CLV</span> <span>AOLV</span> <span>OLV/PM</span> <span>AOLV/PM</span> <span>CLV/PM</span> <span>EZOLV</span> </div> Sets the number of motor poles. | 4 (2 - 120)     |

**Note:**

- When  $A1-02 = 0, 1, 3$  [Control Method Selection = V/f, CL-V/f, CLV], the maximum value is 120.
- When  $A1-02 = 2, 4$  [OLV, AOLV], the maximum value is 48.

Auto-Tuning automatically sets this parameter to the value of [Number of Motor Poles].

### ■ E2-05: Motor Line-to-Line Resistance

| No. (Hex.)   | Name                          | Description  | Default (Range)                                       |
|--------------|-------------------------------|--|---|
| E2-05 (0312) | Motor Line-to-Line Resistance | <div style="display: flex; gap: 5px;"> <span>V/f</span> <span>CL-V/f</span> <span>OLV</span> <span>CLV</span> <span>AOLV</span> <span>OLV/PM</span> <span>AOLV/PM</span> <span>CLV/PM</span> <span>EZOLV</span> </div> Sets the line-to-line resistance for the motor stator windings. | Determined by o2-04, C6-01 (0.000 - 65.000 $\Omega$ ) |

**Note:**

This value is the motor line-to-line resistance. Do not set this parameter with the single-phase resistance.

Auto-Tuning automatically sets this parameter. If you cannot do Auto-Tuning, configure the settings, using the test report from the motor manufacturer. You can calculate the motor line-to-line resistance with one of these formulas:

- E-type insulation: [the resistance value ( $\Omega$ ) shown on the test report at 75 °C]  $\times$  0.92
- B-type insulation: [the resistance value ( $\Omega$ ) shown on the test report at 75 °C]  $\times$  0.92
- F-type insulation: [the resistance value ( $\Omega$ ) shown on the test report at 115 °C]  $\times$  0.87

### ■ E2-06: Motor Leakage Inductance

| No. (Hex.)   | Name                     | Description   | Default (Range)                          |
|--------------|--------------------------|---|--|
| E2-06 (0313) | Motor Leakage Inductance | <input type="checkbox"/> V/f <input type="checkbox"/> CL-V/f <input checked="" type="checkbox"/> OLV <input type="checkbox"/> CLV <input type="checkbox"/> AOLV <input type="checkbox"/> OLV/PM <input type="checkbox"/> AOLV/PM <input type="checkbox"/> CLV/PM <input type="checkbox"/> EZOLV<br>Sets the voltage drop from motor leakage inductance when the motor is operating at the rated frequency and rated current. This value is a percentage of Motor Rated Voltage. | Determined by o2-04, C6-01 (0.0 - 60.0%) |

The drive automatically sets this parameter during Auto-Tuning.

#### Note:

The motor nameplate does not usually show the quantity of voltage drop. If you do not know the value of the motor leakage inductance, contact the motor manufacturer to receive a copy of the motor test report.

### ■ E2-07: Motor Saturation Coefficient 1

| No. (Hex.)   | Name                                      | Description   | Default (Range)    |
|--------------|---|---|--------------------|
| E2-07 (0314) | Motor Saturation Coefficient <sup>1</sup> | <input type="checkbox"/> V/f <input type="checkbox"/> CL-V/f <input checked="" type="checkbox"/> OLV <input type="checkbox"/> CLV <input type="checkbox"/> AOLV <input type="checkbox"/> OLV/PM <input type="checkbox"/> AOLV/PM <input type="checkbox"/> CLV/PM <input type="checkbox"/> EZOLV<br>Sets the motor iron-core saturation coefficient at 50% of the magnetic flux. | 0.50 (0.00 - 0.50) |

The drive uses this coefficient when it operates with constant output. The drive uses this coefficient when it operates the motor in the constant output range.

### ■ E2-08: Motor Saturation Coefficient 2

| No. (Hex.)   | Name                                      | Description   | Default (Range)     |
|--------------|---|---|---------------------|
| E2-08 (0315) | Motor Saturation Coefficient <sup>2</sup> | <input type="checkbox"/> V/f <input type="checkbox"/> CL-V/f <input checked="" type="checkbox"/> OLV <input type="checkbox"/> CLV <input type="checkbox"/> AOLV <input type="checkbox"/> OLV/PM <input type="checkbox"/> AOLV/PM <input type="checkbox"/> CLV/PM <input type="checkbox"/> EZOLV<br>Sets the motor iron-core saturation coefficient at 75% of the magnetic flux. | 0.75 (E2-07 - 0.75) |

The drive uses this coefficient when it operates with constant output. The drive uses this coefficient when it operates the motor in the constant output range.

### ■ E2-09: Motor Mechanical Loss

| No. (Hex.)             | Name                  | Description   | Default (Range)    |
|------------------------|-----------------------|---|--------------------|
| E2-09 (0316)<br>Expert | Motor Mechanical Loss | <input type="checkbox"/> V/f <input type="checkbox"/> CL-V/f <input checked="" type="checkbox"/> OLV <input type="checkbox"/> CLV <input type="checkbox"/> AOLV <input type="checkbox"/> OLV/PM <input type="checkbox"/> AOLV/PM <input type="checkbox"/> CLV/PM <input type="checkbox"/> EZOLV<br>Sets the mechanical loss of the motor. It is set as a percentage of E2-11 [Motor Rated Power]. Usually it is not necessary to change this setting. | 0.0% (0.0 - 10.0%) |

Adjust this parameter in these conditions. The drive adds the configured mechanical loss to the torque reference value as a torque compensation value:

- There is a large quantity of torque loss from motor bearing friction.
- There is a large quantity of torque loss in fans and pumps.

### ■ E2-10: Motor Iron Loss

| No. (Hex.)   | Name            | Description  | Default (Range)                          |
|--------------|-----------------|--|--|
| E2-10 (0317) | Motor Iron Loss | <input type="checkbox"/> V/f <input checked="" type="checkbox"/> CL-V/f <input type="checkbox"/> OLV <input type="checkbox"/> CLV <input type="checkbox"/> AOLV <input type="checkbox"/> OLV/PM <input type="checkbox"/> AOLV/PM <input type="checkbox"/> CLV/PM <input type="checkbox"/> EZOLV<br>Sets the motor iron loss. | Determined by o2-04, C6-01 (0 - 65535 W) |

### ■ E2-11: Motor Rated Power

| No. (Hex.)   | Name              | Description  | Default (Range)                            |
|--------------|-------------------|--|--|
| E2-11 (0318) | Motor Rated Power | <input type="checkbox"/> V/f <input type="checkbox"/> CL-V/f <input checked="" type="checkbox"/> OLV <input type="checkbox"/> CLV <input type="checkbox"/> AOLV <input type="checkbox"/> OLV/PM <input type="checkbox"/> AOLV/PM <input type="checkbox"/> CLV/PM <input type="checkbox"/> EZOLV<br>Sets the motor rated output in the units from o1-58 [Motor Power Unit Selection]. | Determined by o2-04, C6-01 (0.00 - 650.00) |

The drive automatically sets this parameter to the value input for “Motor Rated Power” during Auto-Tuning.

### ◆ E3: V/f Pattern for Motor 2

E3 parameters [V/f Pattern for Motor 2] set the control mode and V/f pattern used for motor 2.

**Note:**

V/f preset patterns equivalent to those set with E1-03 [V/f Pattern Selection] are not available for E3 parameters. Use E3-04 [Motor 2 Maximum Output Frequency] to E3-10 [Motor 2 Minimum Output Voltage] to manually set the V/f pattern.

#### ■ Notes on Manually Setting V/f Patterns

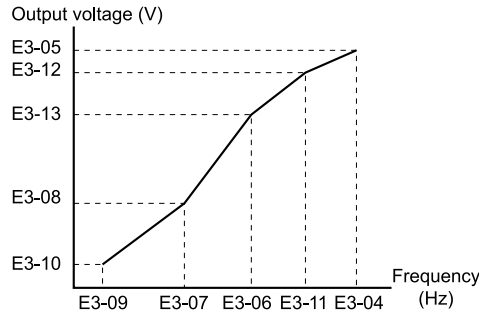


Figure 2.72 Motor 2 V/f Pattern Diagram

- To configure a linear V/f pattern at frequencies lower than E3-06 [Motor 2 Base Frequency], set E3-07 = E3-09 [Motor 2 Mid Point A Frequency = Motor 2 Minimum Output Frequency]. In this application, the drive ignores E1-08 [Mid Point A Voltage].
- Set the five frequencies as specified by these rules:  
 $E3-09 \leq E3-07 < E3-06 \leq E3-11 \leq E3-04$  [Motor 2 Minimum Output Frequency ≤ Motor 2 Mid Point A Frequency < Motor 2 Base Frequency ≤ Motor 2 Mid Point B Frequency ≤ Motor 2 Maximum Output Frequency]  
 Incorrect settings will trigger oPE10 [V/f Data Setting Error].
- If E3-11 = 0.0 Hz, the drive will ignore the V/f pattern settings.
- When you use A1-03 [Initialize Parameters] to initialize the drive, the drive will reset the manually set values for E3-04 to E3-13 [Motor 2 Base Voltage] to default values.

#### ■ E3-01: Motor 2 Control Mode Selection

| No. (Hex.)   | Name                           | Description   | Default (Range) |
|--------------|--------------------------------|---|-----------------|
| E3-01 (0319) | Motor 2 Control Mode Selection | <input type="radio"/> V/f <input type="radio"/> CL-V/f <input type="radio"/> OLV <input type="radio"/> CLV <input type="radio"/> AOLV <input type="radio"/> OLV/PM <input type="radio"/> AOLV/PM <input type="radio"/> CLV/PM <input type="radio"/> EZOLV<br>Sets the control method for motor 2. | 0 (0 - 3)       |

**Note:**

- When you change this setting, the drive will set all parameters that are dependent on this parameter to their default settings.
- Parameter L1-01 [Motor Overload (oL1) Protection] sets the protection operation of oL1 [Motor Overload] the same as Motor 1.
- When you use parameter A1-03 [Initialize Parameters] to initialize the drive, this parameter is not reset.

#### 0 : V/f Control

#### 1 : V/f Control with Encoder

#### 2 : Open Loop Vector

#### 3 : Closed Loop Vector

#### ■ E3-04: Motor 2 Maximum Output Frequency

| No. (Hex.)   | Name                             | Description  | Default (Range)                       |
|--------------|----------------------------------|--|---------------------------------------|
| E3-04 (031A) | Motor 2 Maximum Output Frequency | <input type="radio"/> V/f <input type="radio"/> CL-V/f <input type="radio"/> OLV <input type="radio"/> CLV <input type="radio"/> AOLV <input type="radio"/> OLV/PM <input type="radio"/> AOLV/PM <input type="radio"/> CLV/PM <input type="radio"/> EZOLV<br>Set the maximum output frequency for the motor 2 V/f pattern. | Determined by E3-01 (40.0 - 590.0 Hz) |



### ■ E3-05: Motor 2 Maximum Output Voltage

| No. (Hex.)   | Name                           | Description  | Default (Range)  |
|--------------|--------------------------------|--|--|
| E3-05 (031B) | Motor 2 Maximum Output Voltage | <b>V/f</b> <b>CL-V/f</b> <b>OLV</b> <b>CLV</b> <b>AOLV</b> <b>OLV/PM</b> <b>AOLV/PM</b> <b>CLV/PM</b> <b>EZOLV</b><br>Sets the maximum output voltage for the motor 2 V/f pattern. | Determined by E3-01<br>(200 V Class: 0.0 - 255.0 V,<br>400 V Class: 0.0 - 510.0 V) |

### ■ E3-06: Motor 2 Base Frequency

| No. (Hex.)   | Name                   | Description  | Default (Range)                      |
|--------------|------------------------|--|--------------------------------------|
| E3-06 (031C) | Motor 2 Base Frequency | <b>V/f</b> <b>CL-V/f</b> <b>OLV</b> <b>CLV</b> <b>AOLV</b> <b>OLV/PM</b> <b>AOLV/PM</b> <b>CLV/PM</b> <b>EZOLV</b><br>Sets the base frequency for the motor 2 V/f pattern. | Determined by E3-01<br>(0.0 - E3-04) |

### ■ E3-07: Motor 2 Mid Point A Frequency

| No. (Hex.)   | Name                          | Description   | Default (Range)                      |
|--------------|-------------------------------|---|--------------------------------------|
| E3-07 (031D) | Motor 2 Mid Point A Frequency | <b>V/f</b> <b>CL-V/f</b> <b>OLV</b> <b>CLV</b> <b>AOLV</b> <b>OLV/PM</b> <b>AOLV/PM</b> <b>CLV/PM</b> <b>EZOLV</b><br>Sets a middle output frequency for the motor 2 V/f pattern. | Determined by E3-01<br>(0.0 - E3-04) |

### ■ E3-08: Motor 2 Mid Point A Voltage

| No. (Hex.)   | Name                        | Description   | Default (Range)  |
|--------------|-----------------------------|---|--|
| E3-08 (031E) | Motor 2 Mid Point A Voltage | <b>V/f</b> <b>CL-V/f</b> <b>OLV</b> <b>CLV</b> <b>AOLV</b> <b>OLV/PM</b> <b>AOLV/PM</b> <b>CLV/PM</b> <b>EZOLV</b><br>Sets a middle output voltage for the motor 2 V/f pattern. | Determined by E3-01<br>(200 V Class: 0.0 - 255.0 V,<br>400 V Class: 0.0 - 510.0 V) |

### ■ E3-09: Motor 2 Minimum Output Frequency

| No. (Hex.)   | Name                             | Description  | Default (Range)                      |
|--------------|----------------------------------|--|--------------------------------------|
| E3-09 (031F) | Motor 2 Minimum Output Frequency | <b>V/f</b> <b>CL-V/f</b> <b>OLV</b> <b>CLV</b> <b>AOLV</b> <b>OLV/PM</b> <b>AOLV/PM</b> <b>CLV/PM</b> <b>EZOLV</b><br>Sets the minimum output frequency for the motor 2 V/f pattern. | Determined by E3-01<br>(0.0 - E3-04) |

### ■ E3-10: Motor 2 Minimum Output Voltage

| No. (Hex.)   | Name                           | Description  | Default (Range)  |
|--------------|--------------------------------|--|--|
| E3-10 (0320) | Motor 2 Minimum Output Voltage | <b>V/f</b> <b>CL-V/f</b> <b>OLV</b> <b>CLV</b> <b>AOLV</b> <b>OLV/PM</b> <b>AOLV/PM</b> <b>CLV/PM</b> <b>EZOLV</b><br>Sets the minimum output voltage for the motor 2 V/f pattern. | Determined by E3-01<br>(200 V Class: 0.0 - 255.0 V,<br>400 V Class: 0.0 - 510.0 V) |

### ■ E3-11: Motor 2 Mid Point B Frequency

| No. (Hex.)             | Name                          | Description   | Default (Range)         |
|------------------------|-------------------------------|---|-------------------------|
| E3-11 (0345)<br>Expert | Motor 2 Mid Point B Frequency | <b>V/f</b> <b>CL-V/f</b> <b>OLV</b> <b>CLV</b> <b>AOLV</b> <b>OLV/PM</b> <b>AOLV/PM</b> <b>CLV/PM</b> <b>EZOLV</b><br>Sets a middle output frequency for the motor 2 V/f pattern. Set this parameter to adjust the V/f pattern for the constant output range. Usually it is not necessary to change this parameter. | 0.0 Hz<br>(0.0 - E3-04) |

**Note:**

- Set this parameter to 0.0 to disable the function.
- When you initialize the drive, this parameter is reset to the default value.

## 2.6 E: Motor Parameters

### ■ E3-12: Motor 2 Mid Point B Voltage

| No. (Hex.)                | Name                        | Description   | Default (Range)  |
|---------------------------|-----------------------------|---|--|
| E3-12<br>(0346)<br>Expert | Motor 2 Mid Point B Voltage | <div style="display: flex; gap: 5px;"> <span>V/f</span> <span>CL-V/f</span> <span>OLV</span> <span>CLV</span> <span>AOLV</span> <span>OLV/PM</span> <span>AOLV/PM</span> <span>CLV/PM</span> <span>EZOLV</span> </div> <p>Sets a middle output voltage for the motor 2 V/f pattern. Set this parameter to adjust the V/f pattern for the constant output range. Usually it is not necessary to change this parameter.</p> | 0.0 V<br>(200 V Class: 0.0 to 255.0 V,<br>400 V Class: 0.0 to 510.0 V) |

**Note:**

- Set this parameter to 0.0 to disable the function.
- When you initialize the drive, this parameter is reset to the default value.
- The setting value changes automatically when you do Auto-Tuning (rotational and stationary 1 or 2).

### ■ E3-13: Motor 2 Base Voltage

| No. (Hex.)                | Name                 | Description  | Default (Range)  |
|---------------------------|----------------------|--|--|
| E3-13<br>(0347)<br>Expert | Motor 2 Base Voltage | <div style="display: flex; gap: 5px;"> <span>V/f</span> <span>CL-V/f</span> <span>OLV</span> <span>CLV</span> <span>AOLV</span> <span>OLV/PM</span> <span>AOLV/PM</span> <span>CLV/PM</span> <span>EZOLV</span> </div> <p>Sets the base voltage for the motor 2 V/f pattern. Set this parameter to adjust the V/f pattern for the constant output range. Usually it is not necessary to change this parameter.</p> | 0.0 V<br>(200 V Class: 0.0 to 255.0 V,<br>400 V Class: 0.0 to 510.0 V) |

**Note:**

- When you initialize the drive, this parameter is reset to the default value.
- The setting value changes automatically when you do Auto-Tuning (rotational and stationary 1 or 2).

## ◆ E4: Motor 2 Parameters

*E4 parameters [Motor 2 Parameters]* set induction motor data. To switch drive operation from one motor to a different motor, configure motor 2.

Auto-Tuning automatically sets the *E4 parameters* to the best values for the application. If you cannot do Auto-Tuning, set the *E4 parameters* manually.

**Note:**

*E3-xx* and *E4-xx* are available when *H1-xx = 16* [*MFDI Function Select = Motor 2 Selection*].

### ■ E4-01: Motor 2 Rated Current

| No. (Hex.)      | Name                  | Description   | Default (Range)  |
|-----------------|-----------------------|---|--|
| E4-01<br>(0321) | Motor 2 Rated Current | <div style="display: flex; gap: 5px;"> <span>V/f</span> <span>CL-V/f</span> <span>OLV</span> <span>CLV</span> <span>AOLV</span> <span>OLV/PM</span> <span>AOLV/PM</span> <span>CLV/PM</span> <span>EZOLV</span> </div> <p>Sets the motor rated current for motor 2 in amps.</p> | Determined by o2-04, C6-01<br>(10% to 200% of the drive rated current) |

**Note:**

- If  $E4-01 \leq E4-03$  [*Motor 2 Rated No-Load Current*], the drive will detect *oPE02* [*Parameter Range Setting Error*] will be detected.
- The default settings and setting ranges are in these units:  
 –0.01 A: 2004 to 2042, 4002 to 4023  
 –0.1 A: 2056 to 2415, 4031 to 4720

The value set for *E4-01* becomes the reference value for motor protection, the torque limit, and torque control. Enter the motor rated current written on the motor nameplate. Auto-Tuning automatically sets the value of *E4-01* to the value input for [*Motor Rated Current*].

### ■ E4-02: Motor 2 Rated Slip

| No. (Hex.)      | Name               | Description  | Default (Range)                                   |
|-----------------|--------------------|--|---|
| E4-02<br>(0322) | Motor 2 Rated Slip | <div style="display: flex; gap: 5px;"> <span>V/f</span> <span>CL-V/f</span> <span>OLV</span> <span>CLV</span> <span>AOLV</span> <span>OLV/PM</span> <span>AOLV/PM</span> <span>CLV/PM</span> <span>EZOLV</span> </div> <p>Sets the motor rated slip for motor 2.</p> | Determined by o2-04, C6-01<br>(0.000 - 20.000 Hz) |

The value set in *E4-02* becomes the base slip compensation value. The drive sets this parameter during Rotational Auto-Tuning and Stationary Auto-Tuning. If you cannot do Auto-Tuning, use the information written on the motor nameplate and this formula to calculate the motor rated slip:

$$E4-02 = f - (n \times p) / 120$$

- f: Motor rated frequency (Hz)
- n: Rated motor speed ( $\text{min}^{-1}$  (r/min))
- p: Number of motor poles

### ■ E4-03: Motor 2 Rated No-Load Current

| No. (Hex.)   | Name                          | Description   | Default (Range)                                  |
|--------------|-------------------------------|---|--|
| E4-03 (0323) | Motor 2 Rated No-Load Current | <input type="checkbox"/> V/f <input type="checkbox"/> CL-V/f <input type="checkbox"/> OLV <input type="checkbox"/> CLV <input type="checkbox"/> AOLV <input type="checkbox"/> OLV/PM <input type="checkbox"/> AOLV/PM <input type="checkbox"/> CLV/PM <input type="checkbox"/> EZOLV<br>Sets the no-load current for motor 2 in amps when operating at the rated frequency and the no-load voltage. | Determined by o2-04, C6-01 (Less than 0 - E4-01) |

**Note:**

When the drive model changes, the display units for this parameter also change.

- 0.01 A: 2004 to 2042, 4002 to 4023
- 0.1 A: 2056 to 2415, 4031 to 4720

You can also enter the motor no-load current shown on the motor test report to *E4-03* manually. Contact the motor manufacturer to receive a copy of the motor test report.

**Note:**

The default setting of the no-load current is for a 4-pole motor recommended by Yaskawa.

### ■ E4-04: Motor 2 Motor Poles

| No. (Hex.)   | Name                | Description   | Default (Range) |
|--------------|---------------------|---|-----------------|
| E4-04 (0324) | Motor 2 Motor Poles | <input type="checkbox"/> V/f <input type="checkbox"/> CL-V/f <input type="checkbox"/> OLV <input type="checkbox"/> CLV <input type="checkbox"/> AOLV <input type="checkbox"/> OLV/PM <input type="checkbox"/> AOLV/PM <input type="checkbox"/> CLV/PM <input type="checkbox"/> EZOLV<br>Sets the number of poles for motor 2. | 4 (2 - 120)     |

Auto-Tuning automatically sets *E4-04* to the value input for [Number of Motor Poles].

### ■ E4-05: Motor 2 Line-to-Line Resistance

| No. (Hex.)   | Name                            | Description   | Default (Range)                                       |
|--------------|---------------------------------|---|---|
| E4-05 (0325) | Motor 2 Line-to-Line Resistance | <input type="checkbox"/> V/f <input type="checkbox"/> CL-V/f <input type="checkbox"/> OLV <input type="checkbox"/> CLV <input type="checkbox"/> AOLV <input type="checkbox"/> OLV/PM <input type="checkbox"/> AOLV/PM <input type="checkbox"/> CLV/PM <input type="checkbox"/> EZOLV<br>Sets the line-to-line resistance for the motor 2 stator windings. | Determined by o2-04, C6-01 (0.000 - 65.000 $\Omega$ ) |

**Note:**

This value is the line-to-line resistance for motor 2. Do not use the single-phase resistance to set this parameter.

The drive automatically calculates this value when Auto-Tuning completes successfully. If you cannot do Auto-Tuning, get the test report from the motor manufacturer. To calculate the motor line-to-line resistance, use the information shown on the motor nameplate with one of these formulas:

- E-type insulation: the resistance value ( $\Omega$ ) shown on the test report at  $75\text{ }^\circ\text{C} \times 0.92$
- B-type insulation: the resistance value ( $\Omega$ ) shown on the test report at  $75\text{ }^\circ\text{C} \times 0.92$
- F-type insulation: the resistance value ( $\Omega$ ) shown on the test report at  $115\text{ }^\circ\text{C} \times 0.87$

### ■ E4-06: Motor 2 Leakage Inductance

| No. (Hex.)   | Name                       | Description  | Default (Range)                          |
|--------------|----------------------------|--|--|
| E4-06 (0326) | Motor 2 Leakage Inductance | <input type="checkbox"/> V/f <input type="checkbox"/> CL-V/f <input type="checkbox"/> OLV <input type="checkbox"/> CLV <input type="checkbox"/> AOLV <input type="checkbox"/> OLV/PM <input type="checkbox"/> AOLV/PM <input type="checkbox"/> CLV/PM <input type="checkbox"/> EZOLV<br>Sets the voltage drop from motor 2 leakage inductance as a percentage of Motor Rated Voltage when motor 2 operates at the rated frequency and rated current. | Determined by o2-04, C6-01 (0.0 - 60.0%) |

The drive sets this parameter during Rotational Auto-Tuning and Stationary Auto-Tuning.

**Note:**

You cannot usually find the quantity of voltage drop on the motor nameplate. If you do not know the value of the motor 2 leakage inductance, get the test report from the motor manufacturer.

## 2.6 E: Motor Parameters

### ■ E4-07: Motor 2 Saturation Coefficient 1

| No. (Hex.)      | Name                             | Description  | Default (Range)       |
|-----------------|----------------------------------|--|-----------------------|
| E4-07<br>(0343) | Motor 2 Saturation Coefficient 1 | <input type="checkbox"/> V/f <input type="checkbox"/> CL-V/f <input checked="" type="checkbox"/> OLV <input checked="" type="checkbox"/> CLV <input type="checkbox"/> AOLV <input type="checkbox"/> OLV/PM <input type="checkbox"/> AOLV/PM <input type="checkbox"/> CLV/PM <input type="checkbox"/> EZOLV<br>Sets the motor 2 iron-core saturation coefficient at 50% of the magnetic flux. | 0.50<br>(0.00 - 0.50) |

The drive sets this parameter during Rotational Auto-Tuning. The drive uses this value when it operates the motor in the constant output range.

### ■ E4-08: Motor 2 Saturation Coefficient 2

| No. (Hex.)      | Name                             | Description  | Default (Range)        |
|-----------------|----------------------------------|--|------------------------|
| E4-08<br>(0344) | Motor 2 Saturation Coefficient 2 | <input type="checkbox"/> V/f <input type="checkbox"/> CL-V/f <input checked="" type="checkbox"/> OLV <input checked="" type="checkbox"/> CLV <input type="checkbox"/> AOLV <input type="checkbox"/> OLV/PM <input type="checkbox"/> AOLV/PM <input type="checkbox"/> CLV/PM <input type="checkbox"/> EZOLV<br>Sets the motor 2 iron-core saturation coefficient at 75% of the magnetic flux. | 0.75<br>(E4-07 - 0.75) |

The drive sets this parameter during Rotational Auto-Tuning. The drive uses this value when it operates the motor in the constant output range.

### ■ E4-09: Motor 2 Mechanical Loss

| No. (Hex.)                | Name                    | Description  | Default (Range)       |
|---------------------------|-------------------------|--|-----------------------|
| E4-09<br>(033F)<br>Expert | Motor 2 Mechanical Loss | <input type="checkbox"/> V/f <input type="checkbox"/> CL-V/f <input checked="" type="checkbox"/> OLV <input checked="" type="checkbox"/> CLV <input type="checkbox"/> AOLV <input type="checkbox"/> OLV/PM <input type="checkbox"/> AOLV/PM <input type="checkbox"/> CLV/PM <input type="checkbox"/> EZOLV<br>Sets the mechanical loss of motor 2. It is set as a percentage of E4-11 [Motor 2 Rated Power]. Usually it is not necessary to change this setting. | 0.0%<br>(0.0 - 10.0%) |

Adjust this parameter in these conditions. The drive adds the configured mechanical loss to the torque reference value as a torque compensation value:

- There is a large quantity of torque loss from motor bearing friction.
- There is a large quantity of torque loss in fans and pumps.

### ■ E4-10: Motor 2 Iron Loss

| No. (Hex.)      | Name              | Description   | Default (Range)                             |
|-----------------|-------------------|---|---|
| E4-10<br>(0340) | Motor 2 Iron Loss | <input checked="" type="checkbox"/> V/f <input checked="" type="checkbox"/> CL-V/f <input type="checkbox"/> OLV <input type="checkbox"/> CLV <input type="checkbox"/> AOLV <input type="checkbox"/> OLV/PM <input type="checkbox"/> AOLV/PM <input type="checkbox"/> CLV/PM <input type="checkbox"/> EZOLV<br>Sets the motor iron loss for motor 2. | Determined by o2-04, C6-01<br>(0 - 65535 W) |

### ■ E4-11: Motor 2 Rated Power

| No. (Hex.)      | Name                | Description   | Default (Range)                                  |
|-----------------|---------------------|---|--|
| E4-11<br>(0327) | Motor 2 Rated Power | <input checked="" type="checkbox"/> V/f <input checked="" type="checkbox"/> CL-V/f <input type="checkbox"/> OLV <input checked="" type="checkbox"/> CLV <input type="checkbox"/> AOLV <input type="checkbox"/> OLV/PM <input type="checkbox"/> AOLV/PM <input type="checkbox"/> CLV/PM <input type="checkbox"/> EZOLV<br>Sets the motor rated power in the units from o1-58 [Motor Power Unit Selection]. | Determined by o2-04, C6-01<br>(0.00 - 650.00 kW) |

Auto-Tuning automatically sets this parameter to the value input for [Motor Rated Power].

## ◆ E5: PM Motor Settings

E5 parameters are used to set PM motor data.

Set E5-01 to the motor code when using PM motors recommended by Yaskawa. E5 and other related motor parameters will be automatically set to the optimal values.

Perform Auto-Tuning for all other PM motors. If information from motor nameplates or test reports is available, the E5 parameters can be manually entered.

**Note:**

- The keypad displays E5-xx only when A1-02 = 5, 6, 7 [Control Method Selection = OLV/PM, AOLV/PM, CLV/PM].
- E5-xx parameters are not reset when the drive is initialized using parameter A1-03 [Initialize Parameters].

■ E5-01: PM Motor Code Selection

| No. (Hex.)   | Name                    | Description  | Default (Range)    |
|--------------|-------------------------|--|--------------------|
| E5-01 (0329) | PM Motor Code Selection | <div style="display: flex; justify-content: space-between; font-size: 0.8em;"> <span>V/f</span> <span>CL-V/f</span> <span>OLV</span> <span>CLV</span> <span>AOLV</span> <span style="background-color: #cccccc;">OLV/PM</span> <span style="background-color: #cccccc;">AOLV/PM</span> <span style="background-color: #cccccc;">CLV/PM</span> <span style="background-color: #cccccc;">EZOLV</span> </div> <p>Sets the motor code for Yaskawa PM motors. The drive uses the motor code to set some parameters to their correct settings automatically.</p> | FFFF (0000 - FFFF) |

**Note:**

- If the drive hunts or shows an alarm after you use a motor code, use the keypad to enter the value shown on the nameplate to E5-xx.
- When you use a PM motor other than a Yaskawa SMRA, SSR1, or SST4 series, set E5-01 = FFFF.

Figure 2.73 gives information about the motor code setting digits.

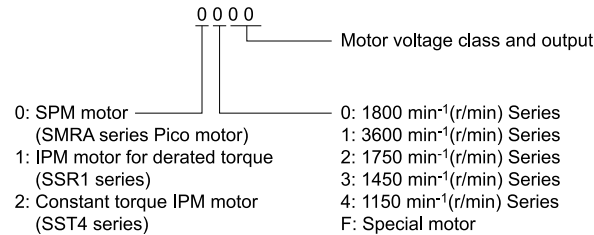


Figure 2.73 PM Motor Code

■ E5-02: PM Motor Rated Power (kW)

| No. (Hex.)   | Name                      | Description   | Default (Range)                        |
|--------------|---------------------------|---|--|
| E5-02 (032A) | PM Motor Rated Power (kW) | <div style="display: flex; justify-content: space-between; font-size: 0.8em;"> <span>V/f</span> <span>CL-V/f</span> <span>OLV</span> <span>CLV</span> <span>AOLV</span> <span style="background-color: #cccccc;">OLV/PM</span> <span style="background-color: #cccccc;">AOLV/PM</span> <span style="background-color: #cccccc;">CLV/PM</span> <span style="background-color: #cccccc;">EZOLV</span> </div> <p>Sets the PM motor rated output in the unit set by 01-58 [Motor Power Unit Selection].</p> | Determined by E5-01 (0.10 - 650.00 kW) |

This parameter will be automatically set the next time you perform Auto-Tuning.

- PM Motor Parameter Settings
- PM Stationary Auto-Tuning
- PM Rotational Auto-Tuning

■ E5-03: PM Motor Rated Current (FLA)

| No. (Hex.)   | Name                         | Description  | Default (Range)  |
|--------------|------------------------------|--|--|
| E5-03 (032B) | PM Motor Rated Current (FLA) | <div style="display: flex; justify-content: space-between; font-size: 0.8em;"> <span>V/f</span> <span>CL-V/f</span> <span>OLV</span> <span>CLV</span> <span>AOLV</span> <span style="background-color: #cccccc;">OLV/PM</span> <span style="background-color: #cccccc;">AOLV/PM</span> <span style="background-color: #cccccc;">CLV/PM</span> <span style="background-color: #cccccc;">EZOLV</span> </div> <p>Sets the PM motor rated current (FLA).</p> | Determined by E5-01 (10% to 200% of the drive rated current) |

**Note:**

- When the drive model changes, the display units for this parameter also change.
- 0.01 A: 2004 to 2042, 4002 to 4023
  - 0.1 A: 2056 to 2415, 4031 to 4720

The drive automatically sets E5-03 to the value input for “PM Motor Rated Current” after you do these types of Auto-Tuning:

- PM Motor Parameter Settings
- PM Stationary Auto-Tuning
- PM StaTun for Stator Resistance
- PM Rotational Auto-Tuning

■ E5-04: PM Motor Pole Count

| No. (Hex.)   | Name                | Description  | Default (Range) |
|--------------|---------------------|--|-----------------|
| E5-04 (032C) | PM Motor Pole Count | <div style="display: flex; justify-content: space-between; font-size: 0.8em;"> <span>V/f</span> <span>CL-V/f</span> <span>OLV</span> <span>CLV</span> <span>AOLV</span> <span style="background-color: #cccccc;">OLV/PM</span> <span style="background-color: #cccccc;">AOLV/PM</span> <span style="background-color: #cccccc;">CLV/PM</span> <span style="background-color: #cccccc;">EZOLV</span> </div> <p>Sets the number of PM motor poles.</p> | 4 (2 - 120)     |

## 2.6 E: Motor Parameters

**Note:**

- When  $A1-02 = 7$  [Control Method Selection = CLV/PM], the maximum value is 120.
- When  $A1-02 = 5, 6$  or  $8$  [OLV/PM, AOLV/PM or EZOLV], the maximum value is 48.

These types of Auto-Tuning will automatically set this parameter to the value of [Number of Motor Poles]:

- PM Motor Parameter Settings
- PM Stationary Auto-Tuning
- PM Rotational Auto-Tuning

### ■ E5-05: PM Motor Resistance (ohms/phase)

| No. (Hex.)   | Name                             | Description   | Default (Range)                        |
|--------------|----------------------------------|---|--|
| E5-05 (032D) | PM Motor Resistance (ohms/phase) | V/f CL-V/f OLV CLV AOLV <b>OLV/PM</b> AOLV/PM CLV/PM EZOLV<br>Sets the resistance per phase of the PM motors. Set 50% of the line-to-line resistance. | Determined by E5-01 (0.000 - 65.000 Ω) |

PM motor Auto-Tuning automatically sets this parameter to the value of [PM Motor Stator Resistance].

**Note:**

Do not change the setting calculated by Auto-Tuning unless it is necessary.

### ■ E5-06: PM d-axis Inductance (mH/phase)

| No. (Hex.)   | Name                            | Description  | Default (Range)                        |
|--------------|---------------------------------|--|--|
| E5-06 (032E) | PM d-axis Inductance (mH/phase) | V/f CL-V/f OLV CLV AOLV <b>OLV/PM</b> AOLV/PM CLV/PM EZOLV<br>Sets the PM motor d-axis inductance. | Determined by E5-01 (0.00 - 300.00 mH) |

PM motor Auto-Tuning automatically sets this parameter to the value of [PM Motor d-Axis Inductance].

**Note:**

Do not change the setting calculated by Auto-Tuning unless it is necessary.

### ■ E5-07: PM q-axis Inductance (mH/phase)

| No. (Hex.)   | Name                            | Description  | Default (Range)                        |
|--------------|---------------------------------|--|--|
| E5-07 (032F) | PM q-axis Inductance (mH/phase) | V/f CL-V/f OLV CLV AOLV <b>OLV/PM</b> AOLV/PM CLV/PM EZOLV<br>Sets the PM motor q-axis inductance. | Determined by E5-01 (0.00 - 600.00 mH) |

PM motor Auto-Tuning automatically sets this parameter to the value of [PM Motor q-Axis Inductance].

**Note:**

Do not change the setting calculated by Auto-Tuning unless it is necessary.

### ■ E5-09: PM Back-EMF Vpeak (mV/(rad/s))

| No. (Hex.)   | Name                           | Description  | Default (Range)                               |
|--------------|--------------------------------|--|---|
| E5-09 (0331) | PM Back-EMF Vpeak (mV/(rad/s)) | V/f CL-V/f OLV CLV AOLV <b>OLV/PM</b> AOLV/PM CLV/PM EZOLV<br>Sets the peak value of PM motor induced voltage. | Determined by E5-01 (0.0 - 2000.0 mV/(rad/s)) |

Set this parameter when you use an IPM motor with derated torque (SSR1-series) or an IPM motor with constant torque (SST4-series).

PM motor Auto-Tuning automatically sets this parameter to the value of [Back-EMF Voltage Constant (Ke)].

When  $E5-01 = FFFF$ , only set  $E5-09$  or  $E5-24$  [PM Back-EMF L-L  $V_{rms}$  (mV/rpm)] as the induced voltage constant.

**Note:**

When you set this parameter, also set  $E5-24 = 0.0$ . The drive will detect  $oPE08$  [Parameter Selection Error] in these conditions:

- $E5-09 = 0.0$  and  $E5-24 = 0.0$
- $E5-09 \neq 0.0$  and  $E5-24 \neq 0.0$

### ■ E5-11: Encoder Z-Pulse Offset

| No. (Hex.)      | Name                   | Description  | Default (Range)                          |
|-----------------|------------------------|--|--|
| E5-11<br>(0333) | Encoder Z-Pulse Offset | V/f CL-V/f OLV CLV AOLV OLV/PM AOLV/PM <b>CLV/PM</b> EZOLV<br>Sets the encoder Z-pulse offset. | 0.0 degrees<br>(-180.0 - +180.0 degrees) |

The drive uses the PM motor parameter settings and PM Stationary Auto-Tuning to set *E5-11* to the value input for “Encoder Z-Pulse Offset” automatically. The drive uses Z Pulse Offset Tuning or the Rotational Auto-Tuning to set *E5-11*.

### ■ E5-24: PM Back-EMF L-L Vrms (mV/rpm)

| No. (Hex.)      | Name                          | Description   | Default (Range)  |
|-----------------|-------------------------------|---|--|
| E5-24<br>(0353) | PM Back-EMF L-L Vrms (mV/rpm) | V/f CL-V/f OLV CLV AOLV <b>OLV/PM</b> AOLV/PM CLV/PM EZOLV<br>Sets the RMS value for PM motor line voltage. | 0.1<br>Determined by E5-01<br>(0.0 - 6500.0 mV/min <sup>-1</sup> ) |

Set this parameter when you use an SPM motor (SMRA-Series Pico motor).

PM motor Auto-Tuning automatically sets this parameter to the value of [Back-EMF Voltage Constant (Ke)].

When *E5-01* = FFFF, only set *E5-09* [PM Back-EMF  $V_{peak}$  (mV/(rad/s))] or *E5-24* as the induced voltage constant.

#### Note:

When you set this parameter, also set *E5-09* = 0.0. The drive will detect *oPE08* [Parameter Selection Error] in these conditions:

- *E5-09* = 0.0 and *E5-24* = 0.0
- *E5-09* ≠ 0.0 and *E5-24* ≠ 0.0

### ■ E5-25: Polarity Estimation Timeout

| No. (Hex.)                | Name                        | Description   | Default (Range) |
|---------------------------|-----------------------------|---|-----------------|
| E5-25<br>(035E)<br>Expert | Polarity Estimation Timeout | V/f CL-V/f OLV CLV AOLV <b>OLV/PM</b> AOLV/PM CLV/PM EZOLV<br>Sets the function that switches polarity for initial polarity estimation. Usually it is not necessary to change this setting. | 0<br>(0, 1)     |

When “Sd = 1” is shown on the motor nameplate or test report for Yaskawa motors, set this parameter to 1.

**0 : Disabled**

**1 : Enabled**

## ◆ E9: Motor Setting

*E9* parameters are used to configure induction motors, PM motors, and SynRM motors. Configure these parameters only for derating torque applications in which a high level of responsiveness and accurate speed control are not required.

*E9* parameters are automatically configured with values input by the Auto-Tuning process for motor parameter settings. *E9* parameters can be manually configured when the EZ Tuning process cannot be performed.

### ■ E9-01: Motor Type Selection

| No. (Hex.)      | Name                 | Description   | Default (Range) |
|-----------------|----------------------|---|-----------------|
| E9-01<br>(11E4) | Motor Type Selection | V/f CL-V/f OLV CLV AOLV OLV/PM AOLV/PM CLV/PM <b>EZOLV</b><br>Sets the type of motor. | 0<br>(0 to 2)   |

EZ Tuning automatically sets this parameter to the value of [Motor Type Selection].

**0 : Induction (IM)**

**1 : Permanent Magnet (PM)**

**2 : Synchronous Reluctance (SynRM)**

## 2.6 E: Motor Parameters

### ■ E9-02: Maximum Speed

| No. (Hex.)   | Name                  | Description  | Default (Range)                       |
|--------------|-----------------------|--|---------------------------------------|
| E9-02 (11E5) | Motor Max Revolutions | V/f CL-V/f OLV CLV AOLV OLV/PM AOLV/PM CLV/PM <b>EZOLV</b><br>Sets the maximum speed of the motor. | Determined by E9-01 (40.0 - 120.0 Hz) |

**Note:**

The unit of measure changes when the setting of *o1-04 [V/f Pattern Display Unit]*.

EZ Tuning automatically sets this parameter to the value of [Motor Max Revolutions].

### ■ E9-03: Rated Speed

| No. (Hex.)   | Name                    | Description   | Default (Range)                                     |
|--------------|-------------------------|---|---|
| E9-03 (11E6) | Motor Rated Revolutions | V/f CL-V/f OLV CLV AOLV OLV/PM AOLV/PM CLV/PM <b>EZOLV</b><br>Sets the rated rotation speed of the motor. | Determined by E9-01 (100 - 7200 min <sup>-1</sup> ) |

EZ Tuning automatically sets this parameter to the value of [Rated Speed].

**Note:**

Set *E9-01 = 0 [Motor Type Selection = Induction (IM)]* before you set this parameter.

### ■ E9-04: Base Frequency

| No. (Hex.)   | Name                  | Description  | Default (Range)                       |
|--------------|-----------------------|--|---------------------------------------|
| E9-04 (11E7) | Motor Rated Frequency | V/f CL-V/f OLV CLV AOLV OLV/PM AOLV/PM CLV/PM <b>EZOLV</b><br>Sets the rated frequency of the motor. | Determined by E9-01 (40.0 - 120.0 Hz) |

**Note:**

The unit of measure changes when the setting of *o1-04 [V/f Pattern Display Unit]*.

EZ Tuning automatically sets this parameter to the value of [Base Frequency].

### ■ E9-05: Base Voltage

| No. (Hex.)   | Name                | Description  | Default (Range)  |
|--------------|---------------------|--|--|
| E9-05 (11E8) | Motor Rated Voltage | V/f CL-V/f OLV CLV AOLV OLV/PM AOLV/PM CLV/PM <b>EZOLV</b><br>Sets the rated voltage of the motor. | 200 V Class: 230.0 V, 400 V: 460.0 V<br>(200 V Class: 0.0 - 255.0 V, 400 V Class: 0.0 - 510.0 V) |

EZ Tuning automatically sets this parameter to the value of [Base Voltage].

### ■ E9-06: Motor Rated Current (FLA)

| No. (Hex.)   | Name                      | Description   | Default (Range)  |
|--------------|---------------------------|---|--|
| E9-06 (11E9) | Motor Rated Current (FLA) | V/f CL-V/f OLV CLV AOLV OLV/PM AOLV/PM CLV/PM <b>EZOLV</b><br>Sets the motor rated current in amps. | Determined by E9-01 and <i>o2-04</i><br>(10% to 200% of the drive rated current) |

**Note:**

When the drive model changes, the display units for this parameter also change.

- 0.01 A: 2004 to 2042, 4002 to 4023
- 0.1 A: 2056 to 2415, 4031 to 4720

The setting value of *E9-06* is the reference value for motor protection. Enter the motor rated current shown on the motor nameplate. Auto-Tuning the drive will automatically set *E9-06* to the value input for “Motor Rated Current”.



### ■ E9-07: Motor Rated Power

| No. (Hex.)   | Name                      | Description  | Default (Range)                                     |
|--------------|---------------------------|--|---|
| E9-07 (11EA) | PM Motor Rated Power (kW) | V/f CL-V/f OLV CLV AOLV OLV/PM AOLV/PM CLV/PM <b>EZOLV</b><br>Sets the motor rated power in the units from o1-58 [Motor Power Unit Selection]. | Determined by E9-02 and o2-04<br>(0.00 - 650.00 kW) |

Auto-Tuning automatically sets this parameter to the value of [Motor Rated Power (kW)].

### ■ E9-08: Motor Pole Count

| No. (Hex.)   | Name             | Description   | Default (Range) |
|--------------|------------------|---|-----------------|
| E9-08 (11EB) | Motor Pole Count | V/f CL-V/f OLV CLV AOLV OLV/PM AOLV/PM CLV/PM <b>EZOLV</b><br>Sets the number of motor poles. | 4<br>(2 to 120) |

Auto-Tuning automatically sets this parameter to the value of [Number of Motor Poles].

### ■ E9-09: Motor Rated Slip

| No. (Hex.)   | Name             | Description  | Default (Range)                 |
|--------------|------------------|--|---------------------------------|
| E9-09 (11EC) | Motor Rated Slip | V/f CL-V/f OLV CLV AOLV OLV/PM AOLV/PM CLV/PM <b>EZOLV</b><br>Sets the motor rated slip. | 0.000 Hz<br>(0.000 - 20.000 Hz) |

The setting value of this parameter is the slip compensation reference value.

The drive uses the setting values of E9-03, E9-04, and E9-08 to calculate this parameter. When Motor Rated Slip = 0, Auto-Tuning automatically sets this parameter to the value of [Motor Rated Slip].

**Note:**

Set E9-01 = 0 [Motor Type Selection = Induction (IM)] before you set this parameter.

### ■ E9-10: Motor Line-to-Line Resistance

| No. (Hex.)   | Name                          | Description   | Default (Range)                           |
|--------------|-------------------------------|---|---|
| E9-10 (11ED) | Motor Line-to-Line Resistance | V/f CL-V/f OLV CLV AOLV OLV/PM AOLV/PM CLV/PM <b>EZOLV</b><br>Sets the line-to-line resistance for the motor stator windings. | Determined by o2-04<br>(0.000 - 65.000 Ω) |

**Note:**

This value is the motor line-to-line resistance. Do not set this parameter with the single-phase resistance.

Stationary Auto-Tuning automatically sets this parameter. If you cannot do Stationary Auto-Tuning, use the test report from the motor manufacturer. You can calculate the motor line-to-line resistance with one of these formulas:

- E-type insulation: the resistance value (Ω) shown on the test report at 75 °C × 0.92
- B-type insulation: the resistance value (Ω) shown on the test report at 75 °C × 0.92
- F-type insulation: the resistance value (Ω) shown on the test report at 115 °C × 0.87

## 2.7 F: Options

*F parameters* are used to set option cards, which function as interfaces for encoders, analog I/O, digital I/O, and fieldbus communication.

### ◆ F1: PG Option Setup (Encoder)

*F1 parameters* are used to set the operation of and protective function for the encoder option card. The following table lists the setting parameters available for each option card.

Refer to the instruction manual packaged with the encoder option card for more information on installing, wiring, and setting the encoder option cards.

**WARNING!** Sudden Movement Hazard. Do test runs and examine the drive to make sure that the command references are correct. If you set the command reference incorrectly, it can cause damage to the drive or serious injury or death.

**WARNING!** Sudden Movement Hazard. Make sure that the host controller circuitry has correct safety design that will let you keep control of the motor if the drive loses speed feedback. If you do not have control of the motor, it can cause serious injury or death.

Table 2.43 Encoder Option Card Setting Parameters

| Setting Parameter | Encoder Option Card |       |       |        |
|-------------------|---------------------|-------|-------|--------|
|                   | PG-B3               | PG-X3 | PG-F3 | PG-RT3 |
| F1-01             | x                   | x     | x     | -      |
| F1-02             | x                   | x     | x     | x      |
| F1-03             | x                   | x     | x     | x      |
| F1-04             | x                   | x     | x     | x      |
| F1-05             | x                   | x     | x     | x      |
| F1-06             | x                   | x     | x     | -      |
| F1-08             | x                   | x     | x     | x      |
| F1-09             | x                   | x     | x     | x      |
| F1-10             | x                   | x     | x     | x      |
| F1-11             | x                   | x     | x     | x      |
| F1-12 */          | x                   | x     | -     | -      |
| F1-13 */          | x                   | x     | -     | -      |
| F1-14             | x                   | x     | x     | x      |
| F1-18             | x                   | x     | x     | x      |
| F1-19             | x                   | x     | x     | x      |
| F1-20             | -                   | x     | x     | -      |
| F1-21             | x                   | x     | -     | -      |
| F1-30             | x                   | x     | -     | -      |
| F1-31 *2          | x                   | x     | -     | -      |
| F1-32 *2          | x                   | x     | -     | -      |
| F1-33 */ *2       | x                   | x     | -     | -      |
| F1-34 */ *2       | x                   | x     | -     | -      |
| F1-35 *2          | x                   | x     | -     | -      |
| F1-36             | -                   | x     | -     | -      |
| F1-37 *2          | x                   | x     | -     | -      |
| F1-50             | -                   | -     | x     | -      |
| F1-51             | -                   | -     | x     | -      |

| Setting Parameter                                | Encoder Option Card |       |       |        |
|--|---------------------|-------|-------|--------|
|  | PG-B3               | PG-X3 | PG-F3 | PG-RT3 |
| F1-52  | -                   | -     | x     | -      |
| Number of cards that can be installed in a drive | 2                   | 2     | 1     | 1      |

\*1 Parameters set when using the Closed Loop V/f Control method.

\*2 Parameters to set an option card connected to CN5-B.

### ■ F1-01: Encoder 1 Pulse Count (PPR)

| No. (Hex.)   | Name                        | Description  | Default (Range)             |
|--------------|-----------------------------|--|-----------------------------|
| F1-01 (0380) | Encoder 1 Pulse Count (PPR) | <div style="display: flex; gap: 5px;"> <span>V/f</span> <span>CL-V/f</span> <span>OLV</span> <span>CLV</span> <span>AOLV</span> <span>OLV/PM</span> <span>AOLV/PM</span> <span>CLV/PM</span> <span>EZOLV</span> </div> Sets the number of output pulses for each motor revolution. | 1024 ppr<br>(1 - 60000 ppr) |

### ■ F1-02: Encoder Signal Loss Detect Sel

| No. (Hex.)   | Name                           | Description  | Default (Range) |
|--------------|--------------------------------|--|-----------------|
| F1-02 (0381) | Encoder Signal Loss Detect Sel | <div style="display: flex; gap: 5px;"> <span>V/f</span> <span>CL-V/f</span> <span>OLV</span> <span>CLV</span> <span>AOLV</span> <span>OLV/PM</span> <span>AOLV/PM</span> <span>CLV/PM</span> <span>EZOLV</span> </div> Sets the method to stop the motor or let the motor continue operating when the drive detects a <i>PGo</i> [Encoder (PG) Feedback Loss]. | 1<br>(0 - 4)    |

If the drive does not detect output pulses from the encoder for the time set in *F1-14* [Encoder Open-Circuit Detect Time], it will trigger *PGo*.

**Note:**

- Motor speed and load conditions can cause *ov* [Overvoltage] and *oC* [Overcurrent] faults.
- In AOLV control, set *n4-72* = 1 [Speed Feedback Mode = With Encoder].

#### 0 : Ramp to Stop

The drive ramps the motor to stop in the deceleration time. Fault relay output terminal MA-MC turns ON, and MB-MC turns OFF.

#### 1 : Coast to Stop

The output turns off and the motor coasts to stop. Fault relay output terminal MA-MC turns ON, and MB-MC turns OFF.

#### 2 : Fast Stop

The drive stops the motor in the deceleration time set in *C1-09* [Fast Stop Time]. Fault relay output terminal MA-MC turns ON, and MB-MC turns OFF.

#### 3 : Alarm Only

The keypad shows *PGo* and the drive continues operation. Only use this setting in special conditions to prevent damage to the motor and machinery. The output terminal set for *Alarm* [H2-01 to H2-03 = 10] turns ON.

#### 4 : No Alarm Display

The drive continues operation and does not show *PGo* on the keypad. Only use this setting in special conditions to prevent damage to the motor and machinery.

### ■ F1-03: Overspeed Detection Selection

| No. (Hex.)   | Name                          | Description  | Default (Range) |
|--------------|-------------------------------|--|-----------------|
| F1-03 (0382) | Overspeed Detection Selection | <div style="display: flex; gap: 5px;"> <span>V/f</span> <span>CL-V/f</span> <span>OLV</span> <span>CLV</span> <span>AOLV</span> <span>OLV/PM</span> <span>AOLV/PM</span> <span>CLV/PM</span> <span>EZOLV</span> </div> Sets the method to stop the motor or let the motor continue operating when the drive detects a <i>oS</i> [Overspeed]. | 1<br>(0 - 3)    |

When the motor speed is more than the value set in *F1-08* [Overspeed Detection Level] for longer than the time set in *F1-09* [Overspeed Detection Delay Time], the drive triggers *oS*.

#### 0 : Ramp to Stop

## 2.7 F: Options

The drive ramps the motor to stop in the deceleration time. Fault relay output terminal MA-MC turns ON, and MB-MC turns OFF.

### 1 : Coast to Stop

The output turns off and the motor coasts to stop. Fault relay output terminal MA-MC turns ON, and MB-MC turns OFF.

### 2 : Fast Stop

The drive stops the motor in the deceleration time set in *C1-09 [Fast Stop Time]*. Fault relay output terminal MA-MC turns ON, and MB-MC turns OFF.

### 3 : Alarm Only

The keypad shows *oS* and the drive continues operation. Only use this setting in special conditions to prevent damage to the motor and machinery. The output terminal set for *Alarm [H2-01 to H2-03 = 10]* turns ON.

**Note:**

When *A1-02 = 6 [Control Method Selection = AOLV/PM]*, the drive will automatically set *F1-03 = 1 [Coast to Stop]*. You cannot change this value.

## ■ F1-04: Speed Deviation Detection Select

| No.<br>(Hex.)   | Name                             | Description   | Default<br>(Range) |
|-----------------|----------------------------------|---|--------------------|
| F1-04<br>(0383) | Speed Deviation Detection Select | <div style="display: flex; justify-content: space-between; align-items: center;"> <span>V/f</span> <span>CL-V/f</span> <span>OLV</span> <span>CLV</span> <span>AOLV</span> <span>OLV/PM</span> <span>AOLV/PM</span> <span>CLV/PM</span> <span>EZOLV</span> </div> <p>Sets the method to stop the motor or let the motor continue operating when the drive detects a <i>dEv</i> [Speed Deviation].</p> | 3<br>(0 - 3)       |

When the difference between the frequency reference and the motor speed is more than the value set in *F1-10 [Speed Deviation Detection Level]* for longer than the time set in *F1-11 [Speed Deviation Detect DelayTime]*, it will trigger *dEv*.

### 0 : Ramp to Stop

The drive ramps the motor to stop in the deceleration time. Fault relay output terminal MA-MC turns ON, and MB-MC turns OFF.

### 1 : Coast to Stop

The output turns off and the motor coasts to stop. Fault relay output terminal MA-MC turns ON, and MB-MC turns OFF.

### 2 : Fast Stop

The drive stops the motor in the deceleration time set in *C1-09 [Fast Stop Time]*. Fault relay output terminal MA-MC turns ON, and MB-MC turns OFF.

### 3 : Alarm Only

The keypad shows *dEv* and the drive continues operation. Only use this setting in special conditions to prevent damage to the motor and machinery. The output terminal set for *Alarm [H2-01 to H2-03 = 10]* turns ON.

## ■ F1-05: Encoder 1 Rotation Selection

| No.<br>(Hex.)   | Name                         | Description   | Default<br>(Range)            |
|-----------------|------------------------------|---|-------------------------------|
| F1-05<br>(0384) | Encoder 1 Rotation Selection | <div style="display: flex; justify-content: space-between; align-items: center;"> <span>V/f</span> <span>CL-V/f</span> <span>OLV</span> <span>CLV</span> <span>AOLV</span> <span>OLV/PM</span> <span>AOLV/PM</span> <span>CLV/PM</span> <span>EZOLV</span> </div> <p>Sets the output sequence for the A and B pulses from the encoder, assuming that the motor is operating in the forward direction.</p> | Determined by A1-02<br>(0, 1) |

Refer to the option card installation manual for more information about how to set the encoder pulse output sequence and make sure that it is correct.

### 0 : Pulse A leads in FWD Direction

### 1 : Pulse B leads in FWD Direction

### ■ F1-06: Encoder 1 Pulse Monitor Scaling

| No. (Hex.)   | Name                            | Description   | Default (Range)                          |
|--------------|---------------------------------|---|--|
| F1-06 (0385) | Encoder 1 Pulse Monitor Scaling | <div style="display: flex; justify-content: space-between; font-size: 0.8em;"> <span>V/f</span> <span>CL-V/f</span> <span>OLV</span> <span>CLV</span> <span>AOLV</span> <span>OLV/PM</span> <span>AOLV/PM</span> <span>CLV/PM</span> <span>EZOLV</span> </div> <p>Sets the ratio between the pulse input and the pulse output of the encoder as a 3-digit number. The first digit is the numerator and the second and third digits set the denominator.</p> | 001<br>(001 - 032, 102 - 132 (1 - 1/32)) |

When the setting value is a 3-digit value (xyz), the dividing ratio is  $(1 + x)/yz$

For example, when  $F1-06 = 032$ , the dividing ratio is  $1/32$ .

#### Note:

When you use a single-pulse encoder, the dividing ratio for the monitor signal is 1:1

### ■ F1-08: Overspeed Detection Level

| No. (Hex.)   | Name                      | Description  | Default (Range)    |
|--------------|---------------------------|--|--------------------|
| F1-08 (0387) | Overspeed Detection Level | <div style="display: flex; justify-content: space-between; font-size: 0.8em;"> <span>V/f</span> <span>CL-V/f</span> <span>OLV</span> <span>CLV</span> <span>AOLV</span> <span>OLV/PM</span> <span>AOLV/PM</span> <span>CLV/PM</span> <span>EZOLV</span> </div> <p>Sets the detection level of <math>oS</math> [Overspeed] as a percentage when the maximum output frequency is 100%.</p> | 115%<br>(0 - 120%) |

When the motor speed is more than the value set in  $F1-08$  for longer than the time set in  $F1-09$  [Overspeed Detection Delay Time], the drive will detect  $oS$ .

### ■ F1-09: Overspeed Detection Delay Time

| No. (Hex.)   | Name                           | Description   | Default (Range)                      |
|--------------|--------------------------------|---|--------------------------------------|
| F1-09 (0388) | Overspeed Detection Delay Time | <div style="display: flex; justify-content: space-between; font-size: 0.8em;"> <span>V/f</span> <span>CL-V/f</span> <span>OLV</span> <span>CLV</span> <span>AOLV</span> <span>OLV/PM</span> <span>AOLV/PM</span> <span>CLV/PM</span> <span>EZOLV</span> </div> <p>Sets the length of time that the speed feedback must be more than the <math>F1-08</math> level to cause an <math>oS</math> [Overspeed].</p> | Determined by A1-02<br>(0.0 - 2.0 s) |

When the motor speed is more than the value set in  $F1-08$  [Overspeed Detection Level] for longer than the time set in  $F1-09$ , the drive will detect  $oS$ .

### ■ F1-10: Speed Deviation Detection Level

| No. (Hex.)   | Name                            | Description   | Default (Range)  |
|--------------|---------------------------------|---|------------------|
| F1-10 (0389) | Speed Deviation Detection Level | <div style="display: flex; justify-content: space-between; font-size: 0.8em;"> <span>V/f</span> <span>CL-V/f</span> <span>OLV</span> <span>CLV</span> <span>AOLV</span> <span>OLV/PM</span> <span>AOLV/PM</span> <span>CLV/PM</span> <span>EZOLV</span> </div> <p>Sets the detection level of <math>dEv</math> [Speed Deviation] as a percentage when the maximum output frequency is 100%.</p> | 10%<br>(0 - 50%) |

When the speed deviation between the frequency reference and the actual motor speed is more than the value set in  $F1-10$  for longer than the time set in  $F1-11$  [Speed Deviation Detect DelayTime], the drive will detect  $dEv$ .

### ■ F1-11: Speed Deviation Detect DelayTime

| No. (Hex.)   | Name                             | Description   | Default (Range)         |
|--------------|----------------------------------|---|-------------------------|
| F1-11 (038A) | Speed Deviation Detect DelayTime | <div style="display: flex; justify-content: space-between; font-size: 0.8em;"> <span>V/f</span> <span>CL-V/f</span> <span>OLV</span> <span>CLV</span> <span>AOLV</span> <span>OLV/PM</span> <span>AOLV/PM</span> <span>CLV/PM</span> <span>EZOLV</span> </div> <p>Sets the length of time that the difference between the frequency reference and speed feedback must be more than the level in <math>F1-10</math> to cause a <math>dEv</math> [Speed Deviation].</p> | 0.5 s<br>(0.0 - 10.0 s) |

When the speed deviation between the frequency reference and the actual motor speed is more than the value set in  $F1-10$  [Speed Deviation Detection Level] for longer than the time set in  $F1-11$ , the drive will detect  $dEv$ .

### ■ F1-12: Encoder 1 Gear Teeth 1

| No. (Hex.)   | Name                   | Description   | Default (Range) |
|--------------|------------------------|---|-----------------|
| F1-12 (038B) | Encoder 1 Gear Teeth 1 | <div style="display: flex; justify-content: space-between; font-size: 0.8em;"> <span>V/f</span> <span>CL-V/f</span> <span>OLV</span> <span>CLV</span> <span>AOLV</span> <span>OLV/PM</span> <span>AOLV/PM</span> <span>CLV/PM</span> <span>EZOLV</span> </div> <p>Sets the number of gear teeth on the motor side. This parameter and <math>F1-13</math> [Encoder 1 Gear Teeth 2] set the gear ratio between the motor and encoder.</p> | 0<br>(0 - 1000) |

## 2.7 F: Options

After you set the number of gear teeth, the drive uses this formula to calculate the motor speed:

$$\text{Motor speed (min}^{-1} \text{ or r/min)} = \frac{\text{Number of pulses from the encoder} \times 60}{F1-01} \times \frac{F1-13}{F1-12}$$

**Note:**

When  $F1-12 = 0$  or  $F1-13 = 0$ , the gear ratio is 1.

### ■ F1-13: Encoder 1 Gear Teeth 2

| No. (Hex.)   | Name                   | Description   | Default (Range) |
|--------------|------------------------|---|-----------------|
| F1-13 (038C) | Encoder 2 Gear Teeth 1 | <div style="display: flex; justify-content: space-between; font-size: 0.8em;"> <span>V/f</span> <span><b>CL-V/f</b></span> <span>OLV</span> <span>CLV</span> <span>AOLV</span> <span>OLV/PM</span> <span>AOLV/PM</span> <span>CLV/PM</span> <span>EZOLV</span> </div> <p>Sets the number of gear teeth on the load side. This parameter and <math>F1-12</math> [Encoder 1 Gear Teeth 1] set the gear ratio between the motor and encoder.</p> | 0<br>(0 - 1000) |

After you set the number of gear teeth, the drive uses this formula to calculate the motor speed:

$$\text{Motor speed (min}^{-1} \text{ or r/min)} = \frac{\text{Number of pulses from the encoder} \times 60}{F1-01} \times \frac{F1-13}{F1-12}$$

**Note:**

When  $F1-12 = 0$  or  $F1-13 = 0$ , the gear ratio is 1.

### ■ F1-14: Encoder Open-Circuit Detect Time

| No. (Hex.)   | Name                             | Description  | Default (Range)         |
|--------------|----------------------------------|--|-------------------------|
| F1-14 (038D) | Encoder Open-Circuit Detect Time | <div style="display: flex; justify-content: space-between; font-size: 0.8em;"> <span>V/f</span> <span><b>CL-V/f</b></span> <span>OLV</span> <span><b>CLV</b></span> <span>AOLV</span> <span>OLV/PM</span> <span>AOLV/PM</span> <span>CLV/PM</span> <span>EZOLV</span> </div> <p>Sets the length of time that the drive must not receive a pulse signal to cause a <i>PGo</i> [Encoder (PG) Feedback Loss].</p> | 2.0 s<br>(0.0 - 10.0 s) |

If the drive does not detect output pulses from the encoder for longer than the time set in  $F1-14$ , the drive will detect *PGo*.

**Note:**

Motor speed and load conditions can cause *ov* [Overvoltage] and *oC* [Overcurrent] faults.

### ■ F1-18: Deviation 3 Detection Selection

| No. (Hex.)   | Name                            | Description  | Default (Range) |
|--------------|---------------------------------|--|-----------------|
| F1-18 (03AD) | Deviation 3 Detection Selection | <div style="display: flex; justify-content: space-between; font-size: 0.8em;"> <span>V/f</span> <span>CL-V/f</span> <span>OLV</span> <span>CLV</span> <span>AOLV</span> <span>OLV/PM</span> <span>AOLV/PM</span> <span><b>CLV/PM</b></span> <span>EZOLV</span> </div> <p>Sets the number of rotations necessary to detect conditions that invert the torque reference and rate of acceleration and cause <i>dv3</i> [Inversion Detection].</p> | 10<br>(0 - 10)  |

When the drive detects these two conditions at the same time for the number of times set in  $F1-18$ , the drive will detect *dv3*.

- The torque reference and acceleration are in opposite directions. For example, torque reference is in forward run and the acceleration is in a negative direction.
- The difference between the speed reference and the actual motor speed is more than 30%.

**Note:**

- Reference the setting value for  $E5-11$  [Encoder Z-Pulse Offset] and the  $\delta\theta$  value found on the motor nameplate. A usual cause for a *dv3* fault is an incorrect  $E5-11$  setting.
- Set  $F1-18 = 0$  to disable the function.

### ■ F1-19: Deviation 4 Detection Selection

| No. (Hex.)   | Name                            | Description  | Default (Range)   |
|--------------|---------------------------------|--|-------------------|
| F1-19 (03AE) | Deviation 4 Detection Selection | <div style="display: flex; justify-content: space-between; font-size: 0.8em;"> <span>V/f</span> <span>CL-V/f</span> <span>OLV</span> <span>CLV</span> <span>AOLV</span> <span>OLV/PM</span> <span>AOLV/PM</span> <span><b>CLV/PM</b></span> <span>EZOLV</span> </div> <p>Sets the number of pulses necessary to cause <i>dv4</i> [Inversion Prevention Detection].</p> | 128<br>(0 - 5000) |

The drive detects a *dv4* [Inversion Prevention Detection] fault when the pulses in a reverse direction to the speed reference are input for longer than the time set in  $F1-19$ .

**Note:**

- Refer to the *E5-11 [Encoder Z-Pulse Offset]* value and the  $\Delta\theta$  value shown on the motor nameplate. An incorrect *E5-11* value will frequently be the cause of a *dv4* fault.
- When you use the drive in an application that rotates the motor from the load side in the reverse direction of the speed reference, set *F1-19* = 0.

### ■ F1-20: Encoder 1 PCB Disconnect Detect

| No. (Hex.)      | Name                            | Description  | Default (Range) |
|-----------------|---------------------------------|--|-----------------|
| F1-20<br>(03B4) | Encoder 1 PCB Disconnect Detect | <div style="display: flex; gap: 5px;"> <span>V/f</span> <span style="background-color: #ccc;">CL-V/f</span> <span>OLV</span> <span style="background-color: #ccc;">CLV</span> <span>AOLV</span> <span>OLV/PM</span> <span>AOLV/PM</span> <span style="background-color: #ccc;">CLV/PM</span> <span>EZOLV</span> </div> Sets the function that enables and disables detection of a disconnected encoder connection cable to cause <i>PGoH [Encoder (PG) Hardware Fault]</i> . | 1<br>(0, 1)     |

**0 : Disabled**

**1 : Enabled**

### ■ F1-21: Encoder 1 Signal Selection

| No. (Hex.)      | Name                       | Description   | Default (Range) |
|-----------------|----------------------------|---|-----------------|
| F1-21<br>(03BC) | Encoder 1 Signal Selection | <div style="display: flex; gap: 5px;"> <span>V/f</span> <span style="background-color: #ccc;">CL-V/f</span> <span>OLV</span> <span>CLV</span> <span>AOLV</span> <span>OLV/PM</span> <span>AOLV/PM</span> <span>CLV/PM</span> <span>EZOLV</span> </div> Sets the number of channels for the signal to the encoder option card. | 0<br>(0, 1)     |

**0 : A Pulse Detection**

**1 : AB Pulse Detection**

### ■ F1-30: Motor 2 Encoder PCB Port Select

| No. (Hex.)      | Name                            | Description  | Default (Range) |
|-----------------|---------------------------------|--|-----------------|
| F1-30<br>(03AA) | Motor 2 Encoder PCB Port Select | <div style="display: flex; gap: 5px;"> <span>V/f</span> <span style="background-color: #ccc;">CL-V/f</span> <span>OLV</span> <span style="background-color: #ccc;">CLV</span> <span>AOLV</span> <span>OLV/PM</span> <span>AOLV/PM</span> <span>CLV/PM</span> <span>EZOLV</span> </div> Sets the drive port to install the motor 2 encoder option card. | 1<br>(0, 1)     |

**0 : CN5-C**

One option card receives the speed feedback signals from motor 1 and motor 2.

**1 : CN5-B**

Two option cards receive the speed feedback signals from motor 1 and motor 2.

### ■ F1-31: Encoder 2 Pulse Count (PPR)

| No. (Hex.)      | Name                        | Description  | Default (Range)             |
|-----------------|-----------------------------|--|-----------------------------|
| F1-31<br>(03B0) | Encoder 2 Pulse Count (PPR) | <div style="display: flex; gap: 5px;"> <span>V/f</span> <span style="background-color: #ccc;">CL-V/f</span> <span>OLV</span> <span style="background-color: #ccc;">CLV</span> <span>AOLV</span> <span>OLV/PM</span> <span>AOLV/PM</span> <span>CLV/PM</span> <span>EZOLV</span> </div> Sets the number of output pulses for each motor revolution for motor 2. | 1024 ppr<br>(1 - 60000 ppr) |

### ■ F1-32: Encoder 2 Rotation Selection

| No. (Hex.)      | Name                         | Description   | Default (Range) |
|-----------------|------------------------------|---|-----------------|
| F1-32<br>(03B1) | Encoder 2 Rotation Selection | <div style="display: flex; gap: 5px;"> <span>V/f</span> <span style="background-color: #ccc;">CL-V/f</span> <span>OLV</span> <span style="background-color: #ccc;">CLV</span> <span>AOLV</span> <span>OLV/PM</span> <span>AOLV/PM</span> <span>CLV/PM</span> <span>EZOLV</span> </div> Sets the output sequence for the A and B pulses from the encoder for motor 2. This parameter assumes that the motor is operating in the forward direction. | 0<br>(0, 1)     |

Refer to the option card installation manual for more information about how to set the encoder pulse output sequence and make sure that it is correct.

**0 : Pulse A leads in FWD Direction**

**1 : Pulse B leads in FWD Direction**

## 2.7 F: Options

### ■ F1-33: Encoder 2 Gear Teeth 1

| No. (Hex.)   | Name                   | Description  | Default (Range) |
|--------------|------------------------|--|-----------------|
| F1-33 (03B2) | Encoder 2 Gear Teeth 1 | <div style="display: flex; justify-content: space-between; font-size: 0.8em;"> <span>V/f</span> <span><b>CL-V/f</b></span> <span>OLV</span> <span>CLV</span> <span>AOLV</span> <span>OLV/PM</span> <span>AOLV/PM</span> <span>CLV/PM</span> <span>EZOLV</span> </div> <p>Sets the number of gear teeth on the motor side for motor 2. This parameter and <i>F1-34 [Encoder 2 Gear Teeth 2]</i> set the gear ratio between the motor and encoder.</p> | 0<br>(0 - 1000) |

After you set the number of gear teeth, the drive uses this formula to calculate the motor speed:

$$\text{Motor speed (min}^{-1} \text{ or r/min)} = \frac{\text{Number of pulses from the encoder} \times 60}{F1-31} \times \frac{F1-33}{F1-34}$$

**Note:**

When *F1-33 = 0* or *F1-34 = 0*, the gear ratio is 1.

### ■ F1-34: Encoder 2 Gear Teeth 2

| No. (Hex.)   | Name                   | Description   | Default (Range) |
|--------------|------------------------|---|-----------------|
| F1-34 (03B3) | Encoder 2 Gear Teeth 2 | <div style="display: flex; justify-content: space-between; font-size: 0.8em;"> <span>V/f</span> <span><b>CL-V/f</b></span> <span>OLV</span> <span>CLV</span> <span>AOLV</span> <span>OLV/PM</span> <span>AOLV/PM</span> <span>CLV/PM</span> <span>EZOLV</span> </div> <p>Sets the number of gear teeth on the load side for motor 2. This parameter and <i>F1-33 [Encoder 2 Gear Teeth 1]</i> set the gear ratio between the motor and encoder.</p> | 0<br>(0 - 1000) |

After you set the number of gear teeth, the drive uses this formula to calculate the motor speed:

$$\text{Motor speed (min}^{-1} \text{ or r/min)} = \frac{\text{Number of pulses from the encoder} \times 60}{F1-31} \times \frac{F1-33 \text{ (load-side PG gear teeth)}}{F1-34 \text{ (motor-side PG gear teeth)}}$$

**Note:**

When *F1-33 = 0* or *F1-34 = 0*, the gear ratio is 1.

### ■ F1-35: Encoder 2 Pulse Monitor Scaling

| No. (Hex.)   | Name                            | Description   | Default (Range)                          |
|--------------|---------------------------------|---|--|
| F1-35 (03BE) | Encoder 2 Pulse Monitor Scaling | <div style="display: flex; justify-content: space-between; font-size: 0.8em;"> <span>V/f</span> <span><b>CL-V/f</b></span> <span>OLV</span> <span><b>CLV</b></span> <span>AOLV</span> <span>OLV/PM</span> <span>AOLV/PM</span> <span>CLV/PM</span> <span>EZOLV</span> </div> <p>Sets the ratio between the pulse input and the pulse output of the encoder as a 3-digit number for motor 2. The first digit is the numerator and the second and third digits set the denominator.</p> | 001<br>(001 - 032, 102 - 132 (1 - 1/32)) |

When the setting value is a 3-digit value (xyz), the dividing ratio is (1 + x)/yz.

For example, when *F1-35 = 032*, the dividing ratio is 1/32.

**Note:**

For a single-pulse encoder, the dividing ratio for the monitor signal is 1:1.

### ■ F1-36: Encoder 2 PCB Disconnect Detect

| No. (Hex.)   | Name                            | Description  | Default (Range) |
|--------------|---------------------------------|--|-----------------|
| F1-36 (03B5) | Encoder 2 PCB Disconnect Detect | <div style="display: flex; justify-content: space-between; font-size: 0.8em;"> <span>V/f</span> <span><b>CL-V/f</b></span> <span>OLV</span> <span><b>CLV</b></span> <span>AOLV</span> <span>OLV/PM</span> <span>AOLV/PM</span> <span>CLV/PM</span> <span>EZOLV</span> </div> <p>Sets the function that enables and disables detection of a disconnected encoder connection cable to cause <i>PGoH [Encoder (PG) Hardware Fault]</i> for motor 2.</p> | 1<br>(0, 1)     |

**0 : Disabled**

**1 : Enabled**

### ■ F1-37: Encoder 2 Signal Selection

| No. (Hex.)   | Name                       | Description   | Default (Range) |
|--------------|----------------------------|---|-----------------|
| F1-37 (03BD) | Encoder 2 Signal Selection | <div style="display: flex; justify-content: space-between; font-size: 0.8em;"> <span>V/f</span> <span><b>CL-V/f</b></span> <span>OLV</span> <span>CLV</span> <span>AOLV</span> <span>OLV/PM</span> <span>AOLV/PM</span> <span>CLV/PM</span> <span>EZOLV</span> </div> <p>Sets the number of channels for the signal to the encoder option card for motor 2.</p> | 0<br>(0, 1)     |

**0 : A Pulse Detection**

**1 : AB Pulse Detection**



### ■ F1-50: PG-F3 Option Encoder Type

| No. (Hex.)   | Name                      | Description   | Default (Range) |
|--------------|---------------------------|---|-----------------|
| F1-50 (03D2) | PG-F3 Option Encoder Type | <div style="display: flex; justify-content: space-between; align-items: center;"> <span>V/f</span> <span>CL-V/f</span> <span>OLV</span> <span>CLV</span> <span>AOLV</span> <span>OLV/PM</span> <span>AOLV/PM</span> <span>CLV/PM</span> <span>EZOLV</span> </div> Sets the type of encoder connected to the PG-F3 option. | 0<br>(0 - 2)    |

**0 : EnDat Sin/Cos**

**1 : EnDat Serial Only**

**2 : HIPERFACE**

### ■ F1-51: PG-F3 PGoH Detection Level

| No. (Hex.)   | Name                       | Description   | Default (Range)   |
|--------------|----------------------------|---|-------------------|
| F1-51 (03D3) | PG-F3 PGoH Detection Level | <div style="display: flex; justify-content: space-between; align-items: center;"> <span>V/f</span> <span>CL-V/f</span> <span>OLV</span> <span>CLV</span> <span>AOLV</span> <span>OLV/PM</span> <span>AOLV/PM</span> <span>CLV/PM</span> <span>EZOLV</span> </div> The drive will detect <i>PGoH</i> [ <i>Encoder (PG) Hardware Fault</i> ] if the value of this parameter is smaller than the value of $\sqrt{\sin^2\theta + \cos^2\theta}$ . | 80%<br>(1 - 100%) |

The drive will detect *PGoH* if the value of this parameter is smaller than the value of  $\sqrt{\sin^2\theta + \cos^2\theta}$ .

Regarding the expression  $\sqrt{\sin^2\theta + \cos^2\theta}$ , Sin  $\theta$  is the single-track (phase B) output from the encoder and Cos  $\theta$  is the single-track (phase A) output from the encoder.

**Note:**

This function is enabled when  $F1-20 = 1$  [*PG Hardware Disconnection Detection Selection = Enabled*].

### ■ F1-52: Serial Encoder Comm Speed

| No. (Hex.)   | Name                      | Description   | Default (Range) |
|--------------|---------------------------|---|-----------------|
| F1-52 (03D4) | Serial Encoder Comm Speed | <div style="display: flex; justify-content: space-between; align-items: center;"> <span>V/f</span> <span>CL-V/f</span> <span>OLV</span> <span>CLV</span> <span>AOLV</span> <span>OLV/PM</span> <span>AOLV/PM</span> <span>CLV/PM</span> <span>EZOLV</span> </div> Sets the communication speed between the PG-F3 option and the serial encoder. | 0<br>(0 - 2)    |

**Note:**

This function is enabled when  $F1-50 = 1$  or  $2$  [*PG-F3 Option Encoder Type = EnDat Serial Only or HIPERFACE*].

**0 : 1M/9600bps**

**1 : 500k/19200bps**

**2 : 1M/38400bps**

## ◆ F2: Analog Input Option

*F2 parameters* set the operation of the drive when you use analog input option card AI-A3. The AI-A3 card has 3 input terminals that accept voltages of -10 V to +10 V (20 k $\Omega$ ) or currents of 4 mA to 20 mA (250  $\Omega$ ). Install the AI-A3 card to enable setting very accurate analog references with high resolution.

Refer to the AI-A3 option manual for more information about how to install, wire, and set the AI-A3 card.

**WARNING!** *Sudden Movement Hazard. Do test runs and examine the drive to make sure that the command references are correct. If you set the command reference incorrectly, it can cause damage to the drive or serious injury or death.*

### ■ F2-01: Analog Input Function Selection

| No. (Hex.)   | Name                            | Description   | Default (Range) |
|--------------|---------------------------------|---|-----------------|
| F2-01 (038F) | Analog Input Function Selection | <div style="display: flex; justify-content: space-between; align-items: center;"> <span>V/f</span> <span>CL-V/f</span> <span>OLV</span> <span>CLV</span> <span>AOLV</span> <span>OLV/PM</span> <span>AOLV/PM</span> <span>CLV/PM</span> <span>EZOLV</span> </div> Sets the input method for the analog reference used with AI-A3. | 0<br>(0, 1)     |

**Note:**

When the AI-A3 card is not mounted in the drive, analog input terminals A1 to A3 on the drive are always enabled. The setting of this parameter does not have an effect.

**0 : 3 Independent Channels**

## 2.7 F: Options

Set  $F2-01 = 0$  to increase the precision of A/D conversion when you use the functions for terminals A1 to A3 on the drive as they are. You can input the MFAI signal from terminals V1 through V3 for AI-A3. The functions for terminals A1, A2, and A3 on the drive are sent to terminals V1, V2, and V3 for AI-A3. Use gain and bias adjustment when you input current to set signals to have negative numbers.

**Note:**

- Set  $b1-01 = 1$  [Frequency Reference Selection 1 = Analog Input] to set inputs individually.
- If  $F2-01 = 0$  and  $b1-01 = 3$  [Option PCB], the drive will detect  $oPE05$  [Run Cmd/Freq Ref Source Sel Err].

Figure 2.74 shows the individual input of analog inputs.  $H3-xx$  parameters set the function to input the analog reference received from the AI-A3 card and to adjust the gain and bias of these signals.

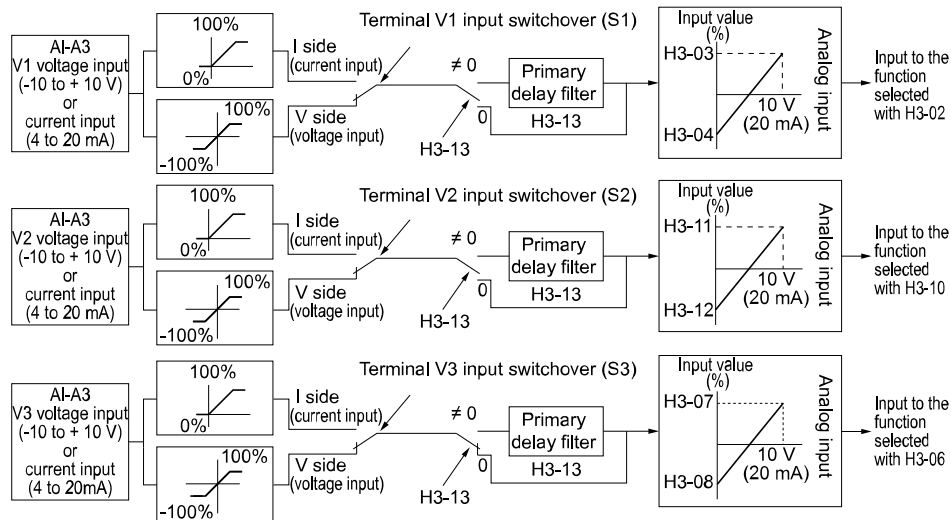


Figure 2.74 Analog Input Reference Individual Input Block Diagram

### 1 : 3 Channels Added Together

Set  $b1-01 = 3$  [Option PCB] to set addition input.

You can input the frequency reference directly. The sum value when you add the input from terminals V1 to V3 becomes the frequency reference.

Set  $F2-01 = 1$  to use the AI-A3 card as addition input.

Figure 2.75 shows addition input. Use  $F2-02$  [Analog Input Option Card Gain] and  $F2-03$  [Analog Input Option Card Bias] to adjust the analog reference gain and bias for addition input.

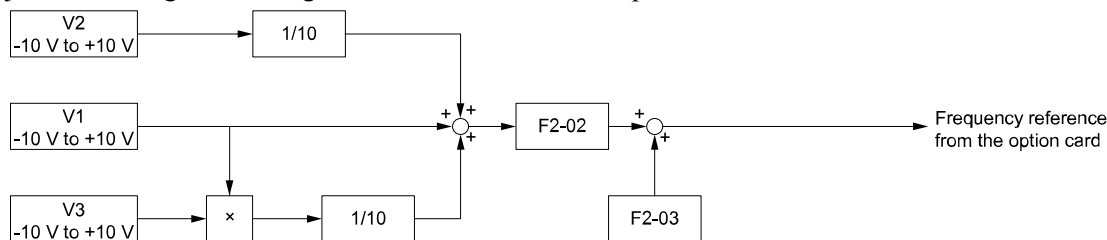


Figure 2.75 Analog Input Reference Addition Input Block Diagram

### Use F2-02 and F2-03 to Adjust the Input Status

When the bias set in  $F2-03$  is 0%, the gain in  $F2-02$  and the addition input value set the ratio (%) of the maximum output frequency output as the frequency reference.

**Note:**

A voltage input of 10 V or a current input of 20 mA is the 100% value for each channel.

The bias set in  $F2-03$  sets the ratio (%) of the maximum output frequency output as the frequency reference when the addition input value is 0%.

**Note:**

A voltage input of 0 V or a current input of 4 mA is the 0% value for each channel.

- **Example 1:**  
When the gain set in  $F2-02$  is 50%, the bias set in  $F2-03$  is 0%, and the addition input value is 100%, the frequency reference is 50% of the maximum output frequency. When the addition input value is 200%, the frequency reference is 100% of the maximum output frequency.
- **Example 2:**  
When the gain set in  $F2-02$  is 200%, the bias set in  $F2-03$  is 0%, and the addition input value is 50%, the frequency reference is equivalent to the maximum output frequency. The frequency reference will not be more than the maximum output frequency, although the addition input value is 50% or higher.
- **Example 3:**  
When the gain set in  $F2-02$  is 100%, the bias set in  $F2-03$  is 30%, and the addition input value is 0%, the frequency reference is 30% of the maximum output frequency. When the addition input value is 70%, the frequency reference will be equivalent to the maximum output frequency. The frequency reference will not be more than the maximum output frequency, although the addition input value is 70% or higher.

### ■ F2-02: Analog Input Option Card Gain

| No. (Hex.)             | Name                          | Description   | Default (Range)              |
|------------------------|-------------------------------|---|------------------------------|
| F2-02<br>(0368)<br>RUN | Analog Input Option Card Gain | <b>V/f</b> <b>CL-V/f</b> <b>OLV</b> <b>CLV</b> <b>AOLV</b> <b>OLV/PM</b> <b>AOLV/PM</b> <b>CLV/PM</b> <b>EZOLV</b><br>Sets the analog reference gain as a percentage when the maximum output frequency is 100%. | 100.0%<br>(-999.9 - +999.9%) |

**Note:**

Set  $F2-01 = 1$  [*Analog Input Function Selection = 3 Channels Added Together*] to enable this function.

### ■ F2-03: Analog Input Option Card Bias

| No. (Hex.)             | Name                          | Description   | Default (Range)            |
|------------------------|-------------------------------|---|----------------------------|
| F2-03<br>(0369)<br>RUN | Analog Input Option Card Bias | <b>V/f</b> <b>CL-V/f</b> <b>OLV</b> <b>CLV</b> <b>AOLV</b> <b>OLV/PM</b> <b>AOLV/PM</b> <b>CLV/PM</b> <b>EZOLV</b><br>Sets the analog reference bias as a percentage when the maximum output frequency is 100%. | 0.0%<br>(-999.9 - +999.9%) |

**Note:**

Set  $F2-01 = 1$  [*Analog Input Function Selection = 3 Channels Added Together*] to enable this function.

### ◆ F3: Digital Input Option

$F3$  parameters set the type of input signal to use with digital input option card DI-A3.

Use these digital inputs to set the frequency reference when you install the DI-A3 card in a drive. Set  $b1-01 = 3$  [*Frequency Reference Selection 1 = Option PCB*] to use this card as the frequency reference input. The input signal is isolated input of 24 Vdc and 8 mA.

- Binary, 16-bit/BCD, 4-digit input
- Binary, 12-bit/BCD, 3-digit input
- Binary, 8-bit/BCD, 2-digit input

You can also use the DI-A3 card as an MFDI, if the setting of  $F3-01$  is correct.

**WARNING! Sudden Movement Hazard.** Do test runs and examine the drive to make sure that the command references are correct. If you set the command reference incorrectly, it can cause damage to the drive or serious injury or death.

#### ■ MFDI for DI-A3

Set  $F3-01 = 8$  [*Digital Input Function Selection = Multi-Function Digital Input*] and  $b1-01 \neq 3$  [*Frequency Reference Selection 1  $\neq$  Option PCB*] to use digital input option DI-A3 as an MFDI.

Use  $F3-10$  to  $F3-25$  [*Terminal D0 Function Selection to Terminal DF Function Selection*] to set the function for the DI-A3 terminals.

## 2.7 F: Options

**Note:**

- Refer to H1-xx “Multi-function Digital Input Setting Values” for more information about MFDI setting values.
- Values 0 [3-Wire Sequence] and 20 to 2F [External Fault] for F3-10 to F3-25.
- When you do not use DI-A3 as an MFDI, set F3-10 to F3-25 = F [Not Used].
- The drive reads DI-A3 terminal Dx two times as specified by parameter b1-06 [Digital Input Reading].
- Configuring such that F3-01 = 8 when DI-A3 is the frequency reference source (b1-01 or b1-15 = 3 [Frequency Reference Selection 1/2 = Option PCB]) results in the detection of oPE05 [Run Cmd/Freq Ref Source Sel Err].
- You can use these functions with the DI-A3 MFDI:  
 –H1-40 to H1-42 [Mbus Reg 15C0h bit0 to bit2 Input Func]  
 –H7-01 to H7-04 [Virtual Multi-Function Input 1 to 4]

### ■ F3-01: Digital Input Function Selection

| No. (Hex.)   | Name                             | Description  | Default (Range) |
|--------------|----------------------------------|--|-----------------|
| F3-01 (0390) | Digital Input Function Selection | <div style="display: flex; justify-content: space-between; font-size: 8px; font-weight: bold;"> <span>V/f</span> <span>CL-V/f</span> <span>OLV</span> <span>CLV</span> <span>AOLV</span> <span>OLV/PM</span> <span>AOLV/PM</span> <span>CLV/PM</span> <span>EZOLV</span> </div> Sets the data format of digital input signals. This parameter is enabled when o1-03 = 0 or 1 [Frequency Display Unit Selection = 0.01 Hz or 0.01% (100% = E1-04)]. | 8<br>(0 - 8)    |

**Note:**

The input signal type is BCD when o1-03 = 2 or 3 [Revolutions Per Minute (RPM) or User Units (o1-10 & o1-11)]. The o1-03 value sets the setting units.

**0 : BCD, 1% units**

**1 : BCD, 0.1% units**

**2 : BCD, 0.01% units**

**3 : BCD, 1 Hz units**

**4 : BCD, 0.1 Hz units**

**5 : BCD, 0.01 Hz units**

**6 : BCD (5-digit), 0.01 Hz**

**7 : Binary input**

The setting unit and setting range vary depending on the value set in F3-03 [Digital Input Data Length Select].

- F3-03 = 0 [8-bit]: 100%/255 (-255 to +255)
- F3-03 = 1 [12-bit]: 100%/4095 (-4095 to +4095)
- F3-03 = 2 [16-bit]: 100%/30000 (-33000 to +33000)

**8 : Multi-Function Digital Input**

The DI-A3 card is also used as a multi-function digital input terminal.

### ■ F3-03: Digital Input Data Length Select

| No. (Hex.)   | Name                             | Description  | Default (Range) |
|--------------|----------------------------------|--|-----------------|
| F3-03 (03B9) | Digital Input Data Length Select | <div style="display: flex; justify-content: space-between; font-size: 8px; font-weight: bold;"> <span>V/f</span> <span>CL-V/f</span> <span>OLV</span> <span>CLV</span> <span>AOLV</span> <span>OLV/PM</span> <span>AOLV/PM</span> <span>CLV/PM</span> <span>EZOLV</span> </div> Sets the number of bits to set the frequency reference with DI-A3. | 2<br>(0 to 2)   |

**0 : 8-bit**

**1 : 12-bit**

**2 : 16-bit**

Table 2.44 DI-A3 Terminal Function Selection

| Terminal Block | Terminal Name | BCD, Signed<br>[F3-01 = 0 to 5]                                    |   |                       |   |                       |                  | BCD, Unsigned<br>[F3-01 = 6] */ |   |                       | Binary, Signed<br>[F3-01 = 7] |                       |                       |
|----------------|---------------|--|---|-----------------------|---|-----------------------|------------------|---------------------------------|---|-----------------------|-------------------------------|-----------------------|-----------------------|
|                |               | 8-bit<br>[F3-03 = 0]   |   | 12-bit<br>[F3-03 = 1] |   | 16-bit<br>[F3-03 = 2] |                  | 8-bit<br>[F3-03 = 0]            | 12-bit<br>[F3-03 = 1]                                   | 16-bit<br>[F3-03 = 2] | 8-bit<br>[F3-03 = 0]          | 12-bit<br>[F3-03 = 1] | 16-bit<br>[F3-03 = 2] |
| TB2            | D0            | 1 digit (0 - 9)  | 1 | 1 digit (0 - 9)       | 1 | 1 digit (0 - 9)       | 1                | 1 digit (0, 2, 4, 6, 8)         | 2   | bit 0                 | bit 0                         | bit 0                 |                       |
|                | D1            |  | 2 |                       | 2 |                       | 2                |                                 | 4   | bit 1                 | bit 1                         | bit 1                 |                       |
|                | D2            |  | 4 |                       | 4 |                       | 4                |                                 | 8   | bit 2                 | bit 2                         | bit 2                 |                       |
|                | D3            |  | 8 |                       | 8 |                       | 8                |                                 | 2 digits (0 - 9)  | 1                     | bit 3                         | bit 3                 | bit 3                 |
|                | D4            | 2 digits (0 - 15) *2   | 1 | 2 digits (0 - 9)      | 1 | 2 digits (0 - 9)      | 1                | 2 digits (0 - 9)                | 2   | bit 4                 | bit 4                         | bit 4                 |                       |
|                | D5            |  | 2 |                       | 2 |                       | 2                |                                 | 4   | bit 5                 | bit 5                         | bit 5                 |                       |
|                | D6            |  | 4 |                       | 4 |                       | 4                |                                 | 8   | bit 6                 | bit 6                         | bit 6                 |                       |
|                | D7            |  | 8 |                       | 8 |                       | 8                |                                 | 3 digits (0 - 9)  | 1                     | bit 7                         | bit 7                 | bit 7                 |
| TB3            | D8            | -  | - | 3 digits (0 - 15) *2  | 1 | 3 digits (0 - 9)      | -                | 3 digits (0 - 9)                | 2   | -                     | bit 8                         | bit 8                 |                       |
|                | D9            | -  | - |                       | 2 |                       | -                |                                 | 4   | -                     | bit 9                         | bit 9                 |                       |
|                | DA            | -  | - |                       | 4 |                       | -                |                                 | 8   | -                     | bit 10                        | bit 10                |                       |
|                | DB            | -  | - |                       | 8 |                       | -                |                                 | 4 digits (0 - 9)  | 1                     | -                             | bit 11                | bit 11                |
|                | DC            | -  | - | -                     | - | 4 digits (0 - 15) *2  | -                | 4 digits (0 - 9)                | 2   | -                     | -                             | bit 12                |                       |
|                | DD            | -  | - | -                     | - |                       | 4                |                                 | -   | -                     | bit 13                        |                       |                       |
|                | DE            | -  | - | -                     | - |                       | 8                |                                 | -   | -                     | bit 14                        |                       |                       |
|                | DF            | -  | - | -                     | - |                       | 5 digits (0 - 3) |                                 | 1   | -                     | -                             | bit 15                |                       |
| TB1            | SI            | SIGN (encoded) signal<br>0: Forward run, 1: Reverse run            |   |                       |   |                       |                  | 2                               | SIGN (encoded) signal<br>0: Forward run, 1: Reverse run |                       |                               |                       |                       |
|                | SE            | SET (loaded) signal<br>1: Loads the value set for D0 to DF and SI. |   |                       |   |                       |                  |                                 |   |                       |                               |                       |                       |
|                | SP            | Internal power supply: 24 V ± 5%                                   |   |                       |   |                       |                  |                                 |   |                       |                               |                       |                       |
|                | SC            | Input signal common  |   |                       |   |                       |                  |                                 |   |                       |                               |                       |                       |
|                | SN            | Internal power supply common: 0 V                                  |   |                       |   |                       |                  |                                 |   |                       |                               |                       |                       |
|                | SD            | Cable sheath connection terminal (ungrounded)                      |   |                       |   |                       |                  |                                 |   |                       |                               |                       |                       |
|                | FE            | Cable sheath connection terminal (grounded)                        |   |                       |   |                       |                  |                                 |   |                       |                               |                       |                       |

\*1 Setting F3-03 = 2 [Digital Input Data Length Select = 16-bit] enables F3-01 = 6 [Digital Input Function Selection = BCD (5-digit), 0.01 Hz] and a frequency between 0.00 Hz to 399.8 Hz can be set by the BCD. Note that terminal SI is also used as for data bits. Negative commands cannot be input as encoding information (positive/negative) cannot be added to the data.

The minimum bit value for the first BCD digit is 2. For this reason, 0.02 Hz is the smallest setting unit available for this frequency setting. An oPE05 [Run Cmd/Freq Ref Source Sel Err] occurs when F3-03 ≠ 2 while F3-01 = 6.

\*2 The most significant digit can be set to a value between 0 to 15 when using "BCD, Signed". Other digits can be set to a value between 0 to 9.

### F3-10: Terminal D0 Function Selection

| No. (Hex.)          | Name                           | Description  | Default (Range) |
|---------------------|--------------------------------|--|-----------------|
| F3-10 (0BE3) Expert | Terminal D0 Function Selection | <span>V/f</span> <span>CL-V/f</span> <span>OLV</span> <span>CLV</span> <span>AOLV</span> <span>OLV/PM</span> <span>AOLV/PM</span> <span>CLV/PM</span> <span>EZOLV</span><br>Sets the function for terminal D0 of the DI-A3 when F3-01 = 8 [Digital Input Function Selection = Multi-Function Digital Input]. | F (1 - 19F)     |

### F3-11: Terminal D1 Function Selection

| No. (Hex.)          | Name                           | Description  | Default (Range) |
|---------------------|--------------------------------|--|-----------------|
| F3-11 (0BE4) Expert | Terminal D1 Function Selection | <span>V/f</span> <span>CL-V/f</span> <span>OLV</span> <span>CLV</span> <span>AOLV</span> <span>OLV/PM</span> <span>AOLV/PM</span> <span>CLV/PM</span> <span>EZOLV</span><br>Sets the function for terminal D1 of the DI-A3 when F3-01 = 8 [Digital Input Function Selection = Multi-Function Digital Input]. | F (1 - 19F)     |

## 2.7 F: Options

### ■ F3-12: Terminal D2 Function Selection

| No.<br>(Hex.)             | Name                           | Description   | Default<br>(Range) |
|---------------------------|--------------------------------|---|--------------------|
| F3-12<br>(0BE5)<br>Expert | Terminal D2 Function Selection | <div style="display: flex; justify-content: space-between; align-items: center;"> <span>V/f</span> <span>CL-V/f</span> <span>OLV</span> <span>CLV</span> <span>AOLV</span> <span>OLV/PM</span> <span>AOLV/PM</span> <span>CLV/PM</span> <span>EZOLV</span> </div> <p>Sets the function for terminal D2 of the DI-A3 when F3-01 = 8 [Digital Input Function Selection = Multi-Function Digital Input].</p> | F<br>(1 - 19F)     |

### ■ F3-13: Terminal D3 Function Selection

| No.<br>(Hex.)             | Name                           | Description   | Default<br>(Range) |
|---------------------------|--------------------------------|---|--------------------|
| F3-13<br>(0BE6)<br>Expert | Terminal D3 Function Selection | <div style="display: flex; justify-content: space-between; align-items: center;"> <span>V/f</span> <span>CL-V/f</span> <span>OLV</span> <span>CLV</span> <span>AOLV</span> <span>OLV/PM</span> <span>AOLV/PM</span> <span>CLV/PM</span> <span>EZOLV</span> </div> <p>Sets the function for terminal D3 of the DI-A3 when F3-01 = 8 [Digital Input Function Selection = Multi-Function Digital Input].</p> | F<br>(1 - 19F)     |

### ■ F3-14: Terminal D4 Function Selection

| No.<br>(Hex.)             | Name                           | Description   | Default<br>(Range) |
|---------------------------|--------------------------------|---|--------------------|
| F3-14<br>(0BE7)<br>Expert | Terminal D4 Function Selection | <div style="display: flex; justify-content: space-between; align-items: center;"> <span>V/f</span> <span>CL-V/f</span> <span>OLV</span> <span>CLV</span> <span>AOLV</span> <span>OLV/PM</span> <span>AOLV/PM</span> <span>CLV/PM</span> <span>EZOLV</span> </div> <p>Sets the function for terminal D4 of the DI-A3 when F3-01 = 8 [Digital Input Function Selection = Multi-Function Digital Input].</p> | F<br>(1 - 19F)     |

### ■ F3-15: Terminal D5 Function Selection

| No.<br>(Hex.)             | Name                           | Description   | Default<br>(Range) |
|---------------------------|--------------------------------|---|--------------------|
| F3-15<br>(0BE8)<br>Expert | Terminal D5 Function Selection | <div style="display: flex; justify-content: space-between; align-items: center;"> <span>V/f</span> <span>CL-V/f</span> <span>OLV</span> <span>CLV</span> <span>AOLV</span> <span>OLV/PM</span> <span>AOLV/PM</span> <span>CLV/PM</span> <span>EZOLV</span> </div> <p>Sets the function for terminal D5 of the DI-A3 when F3-01 = 8 [Digital Input Function Selection = Multi-Function Digital Input].</p> | F<br>(1 - 19F)     |

### ■ F3-16: Terminal D6 Function Selection

| No.<br>(Hex.)             | Name                           | Description   | Default<br>(Range) |
|---------------------------|--------------------------------|---|--------------------|
| F3-16<br>(0BE9)<br>Expert | Terminal D6 Function Selection | <div style="display: flex; justify-content: space-between; align-items: center;"> <span>V/f</span> <span>CL-V/f</span> <span>OLV</span> <span>CLV</span> <span>AOLV</span> <span>OLV/PM</span> <span>AOLV/PM</span> <span>CLV/PM</span> <span>EZOLV</span> </div> <p>Sets the function for terminal D6 of the DI-A3 when F3-01 = 8 [Digital Input Function Selection = Multi-Function Digital Input].</p> | F<br>(1 - 19F)     |

### ■ F3-17: Terminal D7 Function Selection

| No.<br>(Hex.)             | Name                           | Description   | Default<br>(Range) |
|---------------------------|--------------------------------|---|--------------------|
| F3-17<br>(0BEA)<br>Expert | Terminal D7 Function Selection | <div style="display: flex; justify-content: space-between; align-items: center;"> <span>V/f</span> <span>CL-V/f</span> <span>OLV</span> <span>CLV</span> <span>AOLV</span> <span>OLV/PM</span> <span>AOLV/PM</span> <span>CLV/PM</span> <span>EZOLV</span> </div> <p>Sets the function for terminal D7 of the DI-A3 when F3-01 = 8 [Digital Input Function Selection = Multi-Function Digital Input].</p> | F<br>(1 - 19F)     |

### ■ F3-18: Terminal D8 Function Selection

| No.<br>(Hex.)             | Name                           | Description   | Default<br>(Range) |
|---------------------------|--------------------------------|---|--------------------|
| F3-18<br>(0BEB)<br>Expert | Terminal D8 Function Selection | <div style="display: flex; justify-content: space-between; align-items: center;"> <span>V/f</span> <span>CL-V/f</span> <span>OLV</span> <span>CLV</span> <span>AOLV</span> <span>OLV/PM</span> <span>AOLV/PM</span> <span>CLV/PM</span> <span>EZOLV</span> </div> <p>Sets the function for terminal D8 of the DI-A3 when F3-01 = 8 [Digital Input Function Selection = Multi-Function Digital Input].</p> | F<br>(1 - 19F)     |

### ■ F3-19: Terminal D9 Function Selection

| No. (Hex.)                | Name                           | Description   | Default (Range) |
|---------------------------|--------------------------------|---|-----------------|
| F3-19<br>(0BEC)<br>Expert | Terminal D9 Function Selection | <div style="display: flex; justify-content: space-between; gap: 5px;"> <span>V/f</span> <span>CL-V/f</span> <span>OLV</span> <span>CLV</span> <span>AOLV</span> <span>OLV/PM</span> <span>AOLV/PM</span> <span>CLV/PM</span> <span>EZOLV</span> </div> Sets the function for terminal D9 of the DI-A3 when $F3-01 = 8$ [Digital Input Function Selection = Multi-Function Digital Input]. | F<br>(1 - 19F)  |

### ■ F3-20: Terminal DA Function Selection

| No. (Hex.)                | Name                           | Description   | Default (Range) |
|---------------------------|--------------------------------|---|-----------------|
| F3-20<br>(0BED)<br>Expert | Terminal DA Function Selection | <div style="display: flex; justify-content: space-between; gap: 5px;"> <span>V/f</span> <span>CL-V/f</span> <span>OLV</span> <span>CLV</span> <span>AOLV</span> <span>OLV/PM</span> <span>AOLV/PM</span> <span>CLV/PM</span> <span>EZOLV</span> </div> Sets the function for terminal DA of the DI-A3 when $F3-01 = 8$ [Digital Input Function Selection = Multi-Function Digital Input]. | F<br>(1 - 19F)  |

### ■ F3-21: Terminal DB Function Selection

| No. (Hex.)                | Name                           | Description   | Default (Range) |
|---------------------------|--------------------------------|---|-----------------|
| F3-21<br>(0BEE)<br>Expert | Terminal DB Function Selection | <div style="display: flex; justify-content: space-between; gap: 5px;"> <span>V/f</span> <span>CL-V/f</span> <span>OLV</span> <span>CLV</span> <span>AOLV</span> <span>OLV/PM</span> <span>AOLV/PM</span> <span>CLV/PM</span> <span>EZOLV</span> </div> Sets the function for terminal DB of the DI-A3 when $F3-01 = 8$ [Digital Input Function Selection = Multi-Function Digital Input]. | F<br>(1 - 19F)  |

### ■ F3-22: Terminal DC Function Selection

| No. (Hex.)                | Name                           | Description   | Default (Range) |
|---------------------------|--------------------------------|---|-----------------|
| F3-22<br>(0BEF)<br>Expert | Terminal DC Function Selection | <div style="display: flex; justify-content: space-between; gap: 5px;"> <span>V/f</span> <span>CL-V/f</span> <span>OLV</span> <span>CLV</span> <span>AOLV</span> <span>OLV/PM</span> <span>AOLV/PM</span> <span>CLV/PM</span> <span>EZOLV</span> </div> Sets the function for terminal DC of the DI-A3 when $F3-01 = 8$ [Digital Input Function Selection = Multi-Function Digital Input]. | F<br>(1 - 19F)  |

### ■ F3-23: Terminal DD Function Selection

| No. (Hex.)                | Name                           | Description   | Default (Range) |
|---------------------------|--------------------------------|---|-----------------|
| F3-23<br>(0BF0)<br>Expert | Terminal DD Function Selection | <div style="display: flex; justify-content: space-between; gap: 5px;"> <span>V/f</span> <span>CL-V/f</span> <span>OLV</span> <span>CLV</span> <span>AOLV</span> <span>OLV/PM</span> <span>AOLV/PM</span> <span>CLV/PM</span> <span>EZOLV</span> </div> Sets the function for terminal DD of the DI-A3 when $F3-01 = 8$ [Digital Input Function Selection = Multi-Function Digital Input]. | F<br>(1 - 19F)  |

### ■ F3-24: Terminal DE Function Selection

| No. (Hex.)                | Name                           | Description   | Default (Range) |
|---------------------------|--------------------------------|---|-----------------|
| F3-24<br>(0BF1)<br>Expert | Terminal DE Function Selection | <div style="display: flex; justify-content: space-between; gap: 5px;"> <span>V/f</span> <span>CL-V/f</span> <span>OLV</span> <span>CLV</span> <span>AOLV</span> <span>OLV/PM</span> <span>AOLV/PM</span> <span>CLV/PM</span> <span>EZOLV</span> </div> Sets the function for terminal DE of the DI-A3 when $F3-01 = 8$ [Digital Input Function Selection = Multi-Function Digital Input]. | F<br>(1 - 19F)  |

### ■ F3-25: Terminal DF Function Selection

| No. (Hex.)                | Name                           | Description   | Default (Range) |
|---------------------------|--------------------------------|---|-----------------|
| F3-25<br>(0BF2)<br>Expert | Terminal DF Function Selection | <div style="display: flex; justify-content: space-between; gap: 5px;"> <span>V/f</span> <span>CL-V/f</span> <span>OLV</span> <span>CLV</span> <span>AOLV</span> <span>OLV/PM</span> <span>AOLV/PM</span> <span>CLV/PM</span> <span>EZOLV</span> </div> Sets the function for terminal DF of the DI-A3 when $F3-01 = 8$ [Digital Input Function Selection = Multi-Function Digital Input]. | F<br>(1 - 19F)  |

## ◆ F4: Analog Monitor Option

$F4$  parameters set drive operation when you use analog monitor option card AO-A3. The AO-A3 card has 2 output terminals (terminals V1 and V2) for signals with an Output resolution of 11 bits (1/2048) + encoding and that have an

## 2.7 F: Options

output voltage range of -10 V to +10 V. Install the AO-A3 card to a drive to output analog signals that monitor the output status of the drive (output frequency and output current).

Refer to the AO-A3 card manual for more information about how to install, wire, and set the AO-A3 card.

Use the *U monitor* number to set the monitor data to be output from terminals V1 and V2 on the AO-A3 card. Enter the last three digits of *Ux-xx* as the setting value.

- Use Gain and Bias to Adjust the Output Signal Level of Terminal V1

You must stop the drive to adjust the output signal. Use this procedure to calibrate the drive:

1. View the *F4-02 [Terminal V1 Gain]* value on the keypad.  
Terminal V1 will output a voltage = 100% of the monitor set in *F4-01 [Terminal V1 Function Selection]*.
2. View the monitor connected to terminal V1 and adjust *F4-02*.
3. View the *F4-05 [Terminal V1 Bias]* value on the keypad.  
Terminal V1 will output an analog signal = 100% of the parameter set in *F4-01*.
4. View the monitor connected to terminal V1 and adjust *F4-05*.

- Use Gain and Bias to Adjust the Output Signal Level of Terminal V2

You must stop the drive to adjust the output signal. Use this procedure to calibrate the drive:

1. View the *F4-04 [Terminal V2 Gain]* value on the keypad.  
Terminal V2 will output a voltage = 100% of the monitor set in *F4-03 [Terminal V2 Function Selection]*.
2. View the monitor connected to terminal V2 and adjust *F4-04*.
3. View the *F4-06 [Terminal V2 Bias]* value on the keypad.  
The analog signal equal to 0% of the parameter being set in *F4-03* will be output from terminal V2.
4. View the monitor connected to terminal V2 and adjust *F4-06*.

### ■ F4-01: Terminal V1 Function Selection

| No. (Hex.)      | Name                           | Description  | Default (Range)    |
|-----------------|--------------------------------|--|--------------------|
| F4-01<br>(0391) | Terminal V1 Function Selection | <b>V/f</b> <b>CL-V/f</b> <b>OLV</b> <b>CLV</b> <b>AOLV</b> <b>OLV/PM</b> <b>AOLV/PM</b> <b>CLV/PM</b> <b>EZOLV</b><br>Sets the monitor signal output from terminal V1. | 102<br>(000 - 999) |

Enter the last three digits of *Ux-xx [Monitors]* to set monitor data to output from the option card. For example, set *F4-01 = 102* to monitor *U1-02 [Output Frequency]*.

#### Note:

- You cannot use all of the monitors in all of the control methods.
- When you use the terminal in through mode, set this parameter to *000* or *031*. You can set the terminal V1 output level from the PLC through MEMOBUS/Modbus communications or the communication option.

### ■ F4-02: Terminal V1 Gain

| No. (Hex.)             | Name             | Description   | Default (Range)              |
|------------------------|------------------|---|------------------------------|
| F4-02<br>(0392)<br>RUN | Terminal V1 Gain | <b>V/f</b> <b>CL-V/f</b> <b>OLV</b> <b>CLV</b> <b>AOLV</b> <b>OLV/PM</b> <b>AOLV/PM</b> <b>CLV/PM</b> <b>EZOLV</b><br>Sets the gain of the monitor signal that is sent from terminal V1. Sets the analog signal output level from the terminal V1 at 10 V or 20 mA as 100% when an output for monitoring items is 100%. | 100.0%<br>(-999.9 - +999.9%) |

The maximum output voltage output from terminal V1 is  $\pm 10$  V. Use *F4-07 [Terminal V1 Signal Level]* to set the signal level.

Example settings:

When you use these settings, and the monitored output voltage is at 100% (drive rated current), the output voltage of terminal V1 is 5 V (50% of 10 V). The output current is 200% of the drive rated current when terminal V1 outputs a maximum voltage of 10 V.

- F4-01 [Terminal V1 Function Selection] = 102 (U1-02: Output Frequency)
- F4-02 = 50.0%
- F4-05 [Terminal V1 Bias] = 0.0%
- F4-07 = 0 (0 V to 10 V)



### ■ F4-03: Terminal V2 Function Selection

| No. (Hex.)      | Name                           | Description  | Default (Range)    |
|-----------------|--------------------------------|--|--------------------|
| F4-03<br>(0393) | Terminal V2 Function Selection | <div style="display: flex; justify-content: space-between; align-items: center;"> <span>V/f</span> <span>CL-V/f</span> <span>OLV</span> <span>CLV</span> <span>AOLV</span> <span>OLV/PM</span> <span>AOLV/PM</span> <span>CLV/PM</span> <span>EZOLV</span> </div> Sets the monitor signal output from terminal V2. | 103<br>(000 - 999) |

Enter the last three digits of  $U_x-xx$  [Monitors] to set monitor data to output from the option card. For example, set  $F4-03 = 103$  to monitor  $U1-03$  [Output Current].

**Note:**

- You cannot use all of the monitors in all of the control methods.
- When you use the terminal in through mode, set this parameter to 000 or 031. You can use this setting to adjust the V2 terminal output from PLC through MEMOBUS/Modbus communications or a communications option.

### ■ F4-04: Terminal V2 Gain

| No. (Hex.)             | Name             | Description   | Default (Range)             |
|------------------------|------------------|---|-----------------------------|
| F4-04<br>(0394)<br>RUN | Terminal V2 Gain | <div style="display: flex; justify-content: space-between; align-items: center;"> <span>V/f</span> <span>CL-V/f</span> <span>OLV</span> <span>CLV</span> <span>AOLV</span> <span>OLV/PM</span> <span>AOLV/PM</span> <span>CLV/PM</span> <span>EZOLV</span> </div> Sets the gain of the monitor signal that is sent from terminal V2. Sets the analog signal output level from the terminal V2 at 10 V or 20 mA as 100% when an output for monitoring items is 100%. | 50.0%<br>(-999.9 - +999.9%) |

The maximum output voltage output from terminal V2 is  $\pm 10$  V. Use  $F4-08$  [Terminal V2 Signal Level] to set the signal level.

Example settings:

When you use these settings, and the monitored output voltage is at 100% (drive rated current), the output voltage of terminal V2 is 5 V (50% of 10 V). The output current is 200% of the drive rated current when terminal V2 outputs a maximum voltage of 10 V.

- F4-03 [Terminal V2 Function Selection] = 103 (U1-03: Output Current)
- F4-04 = 50.0%
- F4-06 [Terminal V2 Bias] = 0.0%
- F4-08 = 0 (0 V to 10 V)

### ■ F4-05: Terminal V1 Bias

| No. (Hex.)             | Name             | Description   | Default (Range)            |
|------------------------|------------------|---|----------------------------|
| F4-05<br>(0395)<br>RUN | Terminal V1 Bias | <div style="display: flex; justify-content: space-between; align-items: center;"> <span>V/f</span> <span>CL-V/f</span> <span>OLV</span> <span>CLV</span> <span>AOLV</span> <span>OLV/PM</span> <span>AOLV/PM</span> <span>CLV/PM</span> <span>EZOLV</span> </div> Sets the bias of the monitor signal that is sent from terminal V1. When an output for monitoring items is 0%, this parameter sets the analog signal output level from the V1 terminal as a percentage of 10 V or 20 mA. | 0.0%<br>(-999.9 - +999.9%) |

The maximum output voltage output from terminal V1 is  $\pm 10$  V. Use  $F4-07$  [Terminal V1 Signal Level] to set the signal level.

### ■ F4-06: Terminal V2 Bias

| No. (Hex.)             | Name             | Description   | Default (Range)            |
|------------------------|------------------|---|----------------------------|
| F4-06<br>(0396)<br>RUN | Terminal V2 Bias | <div style="display: flex; justify-content: space-between; align-items: center;"> <span>V/f</span> <span>CL-V/f</span> <span>OLV</span> <span>CLV</span> <span>AOLV</span> <span>OLV/PM</span> <span>AOLV/PM</span> <span>CLV/PM</span> <span>EZOLV</span> </div> Sets the bias of the monitor signal that is sent from terminal V2. Set the level of the analog signal sent from the V2 terminal at 10 V or 20 mA as 100% when an output for monitoring items is 0%. | 0.0%<br>(-999.9 - +999.9%) |

The maximum output voltage output from terminal V2 is  $\pm 10$  V. Use  $F4-08$  [Terminal V2 Signal Level] to set the signal level.

## 2.7 F: Options

### ■ F4-07: Terminal V1 Signal Level

| No. (Hex.)      | Name                     | Description   | Default (Range) |
|-----------------|--------------------------|---|-----------------|
| F4-07<br>(0397) | Terminal V1 Signal Level | <b>V/f</b> <b>CL-V/f</b> <b>OLV</b> <b>CLV</b> <b>AOLV</b> <b>OLV/PM</b> <b>AOLV/PM</b> <b>CLV/PM</b> <b>EZOLV</b><br>Sets the output signal level for terminal V1. | 0<br>(0, 1)     |

0 : 0 to 10 V

1 : -10 to 10 V

### ■ F4-08: Terminal V2 Signal Level

| No. (Hex.)      | Name                     | Description   | Default (Range) |
|-----------------|--------------------------|---|-----------------|
| F4-08<br>(0398) | Terminal V2 Signal Level | <b>V/f</b> <b>CL-V/f</b> <b>OLV</b> <b>CLV</b> <b>AOLV</b> <b>OLV/PM</b> <b>AOLV/PM</b> <b>CLV/PM</b> <b>EZOLV</b><br>Sets the output signal level for terminal V2. | 0<br>(0, 1)     |

0 : 0 to 10 V

1 : -10 to 10 V

## ◆ F5: Digital Output Option

*F5 parameters* set the output mode and function of output signals when you use digital output option card DO-A3. When you install a DO-A3 to the drive, you can output isolated digital signals to monitor the drive operation status.

- 6 points of photocoupler output (48 V, 50 mA or less)
- 2 points of relay contact output (250 Vac, 30 Vdc: 1 A or less)

Refer to the DO-A3 option manual for more information about how to install, wire, and set the DO-A3 card.

### ■ Use Parameters to Select Output Modes

Use parameter *F5-09 [DO-A3 Output Mode Selection]* to set signal output from the DO-A3 card.

**Table 2.45 Details of F5-09 and the DO-A3 Terminal Output**

| DO-A3 Terminal Block | DO-A3 Terminal Name | F5-09 = 0 [Predefined Individual Outputs] (Default) | F5-09 = 1 [Binary Output]  | F5-09 = 2 [Programmable (F5-01 to F5-08)]                          |
|----------------------|---------------------|---|--|--|
| TB1                  | M1-M2               | Zero speed detection in progress                    | During run   | Depending on the setting of F5-07 [Terminal M1-M2 Function Select] |
|                      | M3-M4               | During speed agreement                              | Minor fault (excluding bb [Baseblock])                           | Depending on the setting of F5-08 [Terminal M3-M4 Function Select] |
| TB2                  | P1-PC               | oC [Overcurrent], GF [Ground Fault]                 | Coded output<br><b>Note:</b><br>Refer to Table 2.46 for details. | Depending on the setting of F5-01 [Terminal P1-PC Function Select] |
|                      | P2-PC               | ov [Overvoltage]                                    |  | Depending on the setting of F5-02 [Terminal P2-PC Function Select] |
|                      | P3-PC               | oL2 [Drive Overload] or oH2 [Heatsink Overheat]     |  | Depending on the setting of F5-03 [Terminal P3-PC Function Select] |
|                      | P4-PC               | Not used  |  | Depending on the setting of F5-04 [Terminal P4-PC Function Select] |
|                      | P5-PC               | oS [Overspeed]                                      | Zero speed detection in progress                                 | Depending on the setting of F5-05 [Terminal P5-PC Function Select] |
|                      | P6-PC               | oH, oH1 [Heatsink Overheat] or oL1 [Motor Overload] | During speed agreement   | Depending on the setting of F5-06 [Terminal P6-PC Function Select] |

**Table 2.46 Binary Output [F5-09 = 1]**

| Coded Output (Binary) | Description                         | DO-A3 Terminal Block TB2 |                |                |                |
|-----------------------|-------------------------------------|--------------------------|----------------|----------------|----------------|
|                       |                                     | Terminal P1-PC           | Terminal P2-PC | Terminal P3-PC | Terminal P4-PC |
| 0                     | No fault                            | 0                        | 0              | 0              | 0              |
| 1                     | oC [Overcurrent], GF [Ground Fault] | 1                        | 0              | 0              | 0              |
| 2                     | ov [Overvoltage]                    | 0                        | 1              | 0              | 0              |
| 3                     | oL2 [Drive Overloaded]              | 1                        | 1              | 0              | 0              |

| Coded Output (Binary) | Description   | DO-A3 Terminal Block TB2 |                |                |                |
|-----------------------|---|--------------------------|----------------|----------------|----------------|
|                       |   | Terminal P1-PC           | Terminal P2-PC | Terminal P3-PC | Terminal P4-PC |
| 4                     | oH, oH1 [Heatsink Overheat]   | 0                        | 0              | 1              | 0              |
| 5                     | oS [Overspeed]  | 1                        | 0              | 1              | 0              |
| 6                     | Not used  | 0                        | 1              | 1              | 0              |
| 7                     | rr [Dynamic Braking Transistor Fault], rH [Braking Resistor Overheat] | 1                        | 1              | 1              | 0              |
| 8                     | External fault [EF1 to EF8]   | 0                        | 0              | 0              | 1              |
| 9                     | CPFxx, oFAXx, oFbxx, oFCxx [Drive Hardware Fault] *1                  | 1                        | 0              | 0              | 1              |
| A                     | oL1 [Motor Overload]  | 0                        | 1              | 0              | 1              |
| B                     | Not used  | 1                        | 1              | 0              | 1              |
| C                     | Uv1, Uv2 [Undervoltage], Uv3 [Soft Charge Answerback Fault]           | 0                        | 0              | 1              | 1              |
| D                     | dEv [Speed Deviation]   | 1                        | 0              | 1              | 1              |
| E                     | PGo [Encoder (PG) Feedback Loss]                                      | 0                        | 1              | 1              | 1              |
| F                     | Not used  | 1                        | 1              | 1              | 1              |

\*1 The “xx” characters are different for different faults.

## ■ Digital Output Card Selection

Refer to “H2: Multi-function Digital Output” for more information about the functions that output from the terminals when  $F5-09 = 2$  [DO-A3 Output Mode Selection = Programmable (F5-01 to F5-08)]. Use F5-01 to F5-08 to set the output items.

| No.   | Name                           | Setting Range | Default                     |
|-------|--------------------------------|---------------|-----------------------------|
| F5-01 | Terminal P1-PC Function Select | 0 - 192       | 0: During Run               |
| F5-02 | Terminal P2-PC Function Select | 0 - 192       | 1: Zero Speed               |
| F5-03 | Terminal P3-PC Function Select | 0 - 192       | 2: Speed Agree 1            |
| F5-04 | Terminal P4-PC Function Select | 0 - 192       | 4: Frequency Detection 1    |
| F5-05 | Terminal P5-PC Function Select | 0 - 192       | 6: Drive Ready              |
| F5-06 | Terminal P6-PC Function Select | 0 - 192       | 37: During Frequency Output |
| F5-07 | Terminal M1-M2 Function Select | 0 - 192       | F: Not Used                 |
| F5-08 | Terminal M3-M4 Function Select | 0 - 192       | F: Not Used                 |

## ■ F5-01: Terminal P1-PC Function Select

| No. (Hex.)   | Name                           | Description  | Default (Range) |
|--------------|--------------------------------|--|-----------------|
| F5-01 (0399) | Terminal P1-PC Function Select | <div style="display: flex; gap: 5px;"> <span>V/f</span> <span>CL-V/f</span> <span>OLV</span> <span>CLV</span> <span>AOLV</span> <span>OLV/PM</span> <span>AOLV/PM</span> <span>CLV/PM</span> <span>EZOLV</span> </div> Sets the function of terminal P1-PC on the DO-A3 option. Set $F5-09 = 2$ [DO-A3 Output Mode Selection = Programmable (F5-01 to F5-08)] to enable this function. | 0<br>(0 - 1A7)  |

## ■ F5-02: Terminal P2-PC Function Select

| No. (Hex.)   | Name                           | Description  | Default (Range) |
|--------------|--------------------------------|--|-----------------|
| F5-02 (039A) | Terminal P2-PC Function Select | <div style="display: flex; gap: 5px;"> <span>V/f</span> <span>CL-V/f</span> <span>OLV</span> <span>CLV</span> <span>AOLV</span> <span>OLV/PM</span> <span>AOLV/PM</span> <span>CLV/PM</span> <span>EZOLV</span> </div> Sets the function of terminal P2-PC on the DO-A3 option. Set $F5-09 = 2$ [DO-A3 Output Mode Selection = Programmable (F5-01 to F5-08)] to enable this function. | 1<br>(0 - 1A7)  |

## 2.7 F: Options

### ■ F5-03: Terminal P3-PC Function Select

| No. (Hex.)   | Name                           | Description  | Default (Range) |
|--------------|--------------------------------|--|-----------------|
| F5-03 (039B) | Terminal P3-PC Function Select | <div style="display: flex; gap: 5px;"> <span>V/f</span> <span>CL-V/f</span> <span>OLV</span> <span>CLV</span> <span>AOLV</span> <span>OLV/PM</span> <span>AOLV/PM</span> <span>CLV/PM</span> <span>EZOLV</span> </div> <p>Sets the function of terminal P3-PC on the DO-A3 option. Set <i>F5-09 = 2 [DO-A3 Output Mode Selection = Programmable (F5-01 to F5-08)]</i> to enable this function.</p> | 2<br>(0 - 1A7)  |

### ■ F5-04: Terminal P4-PC Function Select

| No. (Hex.)   | Name                           | Description  | Default (Range) |
|--------------|--------------------------------|--|-----------------|
| F5-04 (039C) | Terminal P4-PC Function Select | <div style="display: flex; gap: 5px;"> <span>V/f</span> <span>CL-V/f</span> <span>OLV</span> <span>CLV</span> <span>AOLV</span> <span>OLV/PM</span> <span>AOLV/PM</span> <span>CLV/PM</span> <span>EZOLV</span> </div> <p>Sets the function of terminal P4-PC on the DO-A3 option. Set <i>F5-09 = 2 [DO-A3 Output Mode Selection = Programmable (F5-01 to F5-08)]</i> to enable this function.</p> | 4<br>(0 - 1A7)  |

### ■ F5-05: Terminal P5-PC Function Select

| No. (Hex.)   | Name                           | Description  | Default (Range) |
|--------------|--------------------------------|--|-----------------|
| F5-05 (039D) | Terminal P5-PC Function Select | <div style="display: flex; gap: 5px;"> <span>V/f</span> <span>CL-V/f</span> <span>OLV</span> <span>CLV</span> <span>AOLV</span> <span>OLV/PM</span> <span>AOLV/PM</span> <span>CLV/PM</span> <span>EZOLV</span> </div> <p>Sets the function of terminal P5-PC on the DO-A3 option. Set <i>F5-09 = 2 [DO-A3 Output Mode Selection = Programmable (F5-01 to F5-08)]</i> to enable this function.</p> | 6<br>(0 - 1A7)  |

### ■ F5-06: Terminal P6-PC Function Select

| No. (Hex.)   | Name                           | Description  | Default (Range) |
|--------------|--------------------------------|--|-----------------|
| F5-06 (039E) | Terminal P6-PC Function Select | <div style="display: flex; gap: 5px;"> <span>V/f</span> <span>CL-V/f</span> <span>OLV</span> <span>CLV</span> <span>AOLV</span> <span>OLV/PM</span> <span>AOLV/PM</span> <span>CLV/PM</span> <span>EZOLV</span> </div> <p>Sets the function of terminal P6-PC on the DO-A3 option. Set <i>F5-09 = 2 [DO-A3 Output Mode Selection = Programmable (F5-01 to F5-08)]</i> to enable this function.</p> | 37<br>(0 - 1A7) |

### ■ F5-07: Terminal M1-M2 Function Select

| No. (Hex.)   | Name                           | Description  | Default (Range) |
|--------------|--------------------------------|--|-----------------|
| F5-07 (039F) | Terminal M1-M2 Function Select | <div style="display: flex; gap: 5px;"> <span>V/f</span> <span>CL-V/f</span> <span>OLV</span> <span>CLV</span> <span>AOLV</span> <span>OLV/PM</span> <span>AOLV/PM</span> <span>CLV/PM</span> <span>EZOLV</span> </div> <p>Sets the function of terminal M3-M2 on the DO-A3 option. Set <i>F5-09 = 2 [DO-A3 Output Mode Selection = Programmable (F5-01 to F5-08)]</i> to enable this function.</p> | F<br>(0 - 1A7)  |

### ■ F5-08: Terminal M3-M4 Function Select

| No. (Hex.)   | Name                           | Description  | Default (Range) |
|--------------|--------------------------------|--|-----------------|
| F5-08 (03A0) | Terminal M3-M4 Function Select | <div style="display: flex; gap: 5px;"> <span>V/f</span> <span>CL-V/f</span> <span>OLV</span> <span>CLV</span> <span>AOLV</span> <span>OLV/PM</span> <span>AOLV/PM</span> <span>CLV/PM</span> <span>EZOLV</span> </div> <p>Sets the function of terminal M3-M4 on the DO-A3 option. Set <i>F5-09 = 2 [DO-A3 Output Mode Selection = Programmable (F5-01 to F5-08)]</i> to enable this function.</p> | F<br>(0 - 1A7)  |

### ■ F5-09: DO-A3 Output Mode Selection

| No. (Hex.)   | Name                        | Description  | Default (Range) |
|--------------|-----------------------------|--|-----------------|
| F5-09 (03A1) | DO-A3 Output Mode Selection | <div style="display: flex; gap: 5px;"> <span>V/f</span> <span>CL-V/f</span> <span>OLV</span> <span>CLV</span> <span>AOLV</span> <span>OLV/PM</span> <span>AOLV/PM</span> <span>CLV/PM</span> <span>EZOLV</span> </div> <p>Sets the output mode of signals from the DO-A3 option.</p> | 0<br>(0 - 2)    |

Refer to Table 2.45 for more information.

**0 : Predefined Individual Outputs**

**1 : Binary Output**

**2 : Programmable (F5-01 to F5-08)**

## ◆ F6, F7: Ethernet Options

*F6 and F7 parameters* are used to set the basic communication settings and method of fault detection for the communication option card. The communication option card parameters include common option card parameters and communication protocol-specific parameters.

The following table lists the parameters that need to be set for each communication option card.

Refer to the technical manual for each communication option card for more information on installing, wiring, and configuring the details needed before starting communication.

**WARNING!** *Sudden Movement Hazard. Do test runs and examine the drive to make sure that the command references are correct. If you set the command reference incorrectly, it can cause damage to the drive or serious injury or death.*

**Table 2.47 Correspondence Between Communication Protocols and Parameters (SI-C3, SI-T3, SI-ET3, SI-P3, SI-S3, and SI-ES3)**

| Parameter      | CC-Link<br>SI-C3 | MECHATROLINK-II<br>SI-T3 | MECHATROLINK-III<br>SI-ET3 | PROFIBUS-DP<br>SI-P3 | CANopen<br>SI-S3 | EtherCAT<br>SI-ES3 |
|----------------|------------------|--------------------------|----------------------------|----------------------|------------------|--------------------|
| F6-01 to F6-03 | x                | x                        | x                          | x                    | x                | x                  |
| F6-04          | x                | -                        | -                          | -                    | -                | -                  |
| F6-06 to F6-08 | x                | x                        | x                          | x                    | x                | x                  |
| F6-10, F6-11   | x                | -                        | -                          | -                    | -                | -                  |
| F6-14          | x                | x                        | x                          | x                    | x                | x                  |
| F6-16          | x                | x                        | x                          | x                    | x                | x                  |
| F6-20, F6-21   | -                | x                        | x                          | -                    | -                | -                  |
| F6-22          | -                | x                        | -                          | -                    | -                | -                  |
| F6-23 to F6-26 | -                | x                        | x                          | -                    | -                | -                  |
| F6-30 to F6-32 | -                | -                        | -                          | x                    | -                | -                  |
| F6-35, F6-36   | -                | -                        | -                          | -                    | x                | -                  |
| F6-45 to F6-49 | -                | -                        | -                          | -                    | -                | -                  |
| F6-50 to F6-71 | -                | -                        | -                          | -                    | -                | -                  |
| F7-01 to F7-15 | -                | -                        | -                          | -                    | -                | -                  |
| F7-16          | -                | -                        | -                          | -                    | -                | -                  |
| F7-17 to F7-42 | -                | -                        | -                          | -                    | -                | -                  |
| F7-60 to F7-79 | -                | -                        | -                          | x                    | -                | -                  |

**Table 2.48 Correspondence Between Communication Protocols and Parameters (SI-B3, SI-N3, SI-W3, SI-EM3, SI-EP3, and SI-EN3)**

| Parameter      | DeviceNet<br>SI-N3 | LonWorks<br>SI-W3 | Modbus TCP/IP<br>SI-EM3 | PROFINET<br>SI-EP3 | EtherNet/IP<br>SI-EN3 |
|----------------|--------------------|-------------------|-------------------------|--------------------|-----------------------|
| F6-01 to F6-03 | x                  | x                 | x                       | x                  | x                     |
| F6-04          | -                  | -                 | -                       | -                  | -                     |
| F6-06 to F6-08 | x                  | x                 | x                       | x                  | x                     |
| F6-10, F6-11   | -                  | -                 | -                       | -                  | -                     |
| F6-14          | x                  | x                 | x                       | x                  | x                     |
| F6-16          | x                  | x                 | x                       | x                  | x                     |
| F6-20, F6-21   | -                  | -                 | -                       | -                  | -                     |
| F6-22          | -                  | -                 | -                       | -                  | -                     |
| F6-23 to F6-26 | -                  | -                 | -                       | -                  | -                     |
| F6-30 to F6-32 | -                  | -                 | -                       | -                  | -                     |
| F6-35, F6-36   | -                  | -                 | -                       | -                  | -                     |
| F6-45 to F6-49 | -                  | -                 | -                       | -                  | -                     |

## 2.7 F: Options

| Parameter      | DeviceNet<br>SI-N3 | LonWorks<br>SI-W3 | Modbus TCP/IP<br>SI-EM3 | PROFINET<br>SI-EP3 | EtherNet/IP<br>SI-EN3 |
|----------------|--------------------|-------------------|-------------------------|--------------------|-----------------------|
| F6-50 to F6-71 | x                  | -                 | -                       | -                  | -                     |
| F7-01 to F7-15 | -                  | -                 | x                       | x                  | x                     |
| F7-16          | -                  | -                 | x                       | -                  | -                     |
| F7-17 to F7-42 | -                  | -                 | -                       | x                  | x                     |
| F7-60 to F7-79 | -                  | -                 | -                       | -                  | -                     |

### ■ Gateway Mode

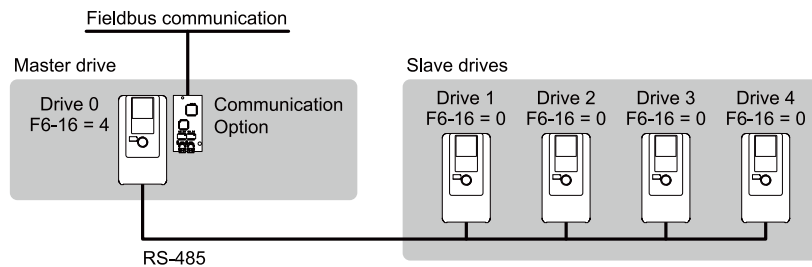
**Note:**

When you use Gateway Mode, do not install the communication option in slave drives. Installing communication options in slave drives makes it impossible to ensure the synchronization of drive commands and responses.

Gateway mode allows you to communicate data with multiple drives using a single communication option.

You can connect up to five drives to the field bus communications through a single communication option. For details, refer to Figure 2.76.

From the master drive with a communication option installed, you can transmit data via the RS-485 communication card so that slave drives without a communication option can receive it.



**Figure 2.76 Connection Examples in Gateway Mode**

**Table 2.49 Specification**

| Item                         | Specification   |
|------------------------------|---|
| Applicable options           | All the options that support the MEMOBUS access function (e.g., PROFIBUS-DP, PROFINET, EtehrNet/IP, EtherCAT, etc.)   |
| Number of drives connected   | Maximum: 5 units  |
| Communication Specifications | MEMOBUS/Modbus (RTUmode) communications   |
| Commands/responses           | The controller can send the following data to each drive (Drive 0 to Drive 4). <ul style="list-style-type: none"> <li>Control commands: Run commands and frequency references</li> <li>Control responses: Output frequency and drive status (during run, faults)</li> <li>Read and write parameters</li> <li>Read monitors</li> </ul> |
| Synchronous control          | Not supported   |

**Note:**

- The communication speed in gateway mode is slower than that in field bus communications. Make sure if the speed is acceptable to your system.
- Response speed with the communication option is slower than with point-to-point communications.
- Set *H5-03 [Communication Parity Selection]* to the same value on the master drive and slave drives.

**WARNING! Injury to Personnel.** Separately prepare safety protection equipment and systems, for example fast stop switches. If the motor does not stop correctly from the disconnection of communications cable or electrical interference, it can cause serious injury.

### Configuring Gateway Mode

Table 2.50 shows sample settings to connect 4 slave drives:

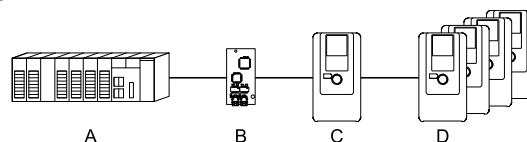
Table 2.50 Sample Settings for Using Gateway Mode

|                           | F6-16<br>[Gateway Mode] | H5-01<br>[Drive Node<br>Address] *1 | H5-02<br>[Communication<br>Speed Selection]<br>H5-03<br>[Communication<br>Parity Selection] | H5-06<br>[Drive Transmit<br>Wait Time] | H5-09<br>[CE Detection<br>Time] | b1-01<br>[Frequency<br>Reference<br>Selection 1] | b1-02<br>[Run Command<br>Selection 1]   |
|---------------------------|-------------------------|-------------------------------------|---|--|---------------------------------|--|---|
| Drive 0<br>(Master Drive) | 1 - 4 *2                | 1F (Default)                        | *5  | 5 ms (factory<br>default) *6           | $\geq 2.0$ s *7                 | 3 [Option PCB]                                   | 3 [Option PCB]                          |
| Drive 1<br>(Slave drive)  | 0                       | 01 *3 *4                            | *5  | 5 ms (factory<br>default) *6           | $\geq 0.9$ s *7                 | 2 [Memobus/Modbus<br>Communications] *8          | 2 [Memobus/Modbus<br>Communications] *8 |
| Drive 2<br>(Slave drive)  | 0                       | 02 *3 *4                            | *5  | 5 ms (factory<br>default) *6           | $\geq 0.9$ s *7                 | 2 [Memobus/Modbus<br>Communications] *8          | 2 [Memobus/Modbus<br>Communications] *8 |
| Drive 3<br>(Slave drive)  | 0                       | 03 *3 *4                            | *5  | 5 ms (factory<br>default) *6           | $\geq 0.9$ s *7                 | 2 [Memobus/Modbus<br>Communications] *8          | 2 [Memobus/Modbus<br>Communications] *8 |
| Drive 4<br>(Slave drive)  | 0                       | 04 *3 *4                            | *5  | 5 ms (factory<br>default) *6           | $\geq 0.9$ s *7                 | 2 [Memobus/Modbus<br>Communications] *8          | 2 [Memobus/Modbus<br>Communications] *8 |

- \*1 Restart the drive to apply the new settings.  
 \*2 Specify the number of slave drives you want to connect.  
 \*3 Setting 0 will not let the drive respond to MEMOBUS/Modbus communications.  
 \*4 Set a slave address that is different from other slave devices.  
 \*5 Enter the same value as for the master drive.  
 \*6 To correctly detect the response timeout, do not change the value of H5-06 from the default value.  
 \*7 Set  $H5-09 \geq 0.9$ . When  $H5-09 < 0.9$ , the drive will detect *CE* [Memobus/Modbus Communication Error] before it detects a response timeout.  
 \*8 On each slave drive, set both b1-01 [Frequency Reference Selection 1] and b1-02 [Run Command Selection 1] to 2 [Memobus/Modbus Communications].

### An Overview of Gateway Mode

When in gateway mode, the drive operates as shown in Table 2.51.



**A - Controller**

**B - Communication Option**

**C - Master Drive (Drive 0)**

**D - Slave Drives (Drives 1 to 4)**

Table 2.51 Operation in Gateway Mode

| Controller to Communication Option Card  | Communication Option Card to Master Drive (Drive 0)  | Master Drive (Drive 0) to Slave Drives (Drives 1 to 4)   |
|--|--|--|
| <ul style="list-style-type: none"> <li>Communications are performed in the format of each field bus communications.</li> <li>Drive 0 sends commands and monitors through normal field bus communications.</li> <li>Drives 1 to 4 receive commands and get monitored through writing to and reading from the special registers of Drive 0.</li> </ul> | Field bus communication data is written to and read from the special registers of Drive 0. | <ul style="list-style-type: none"> <li>MEMOBUS communications are performed.</li> <li>The data from Drive 0 special registers is sent to Drives 1 to 4.</li> </ul> |

## 2.7 F: Options

### Operations at the Time of Communication Error

| Communication Error                       | Error Codes | Operation  |
|---|-------------|--|
| From controller to communication option   | bUS         | <ul style="list-style-type: none"> <li>Master drive<br/>Detects <i>bUS</i> [Option Communication Error] and operates in accordance with <i>F6-01</i> [Communication Error Selection].</li> <li>Slave drive<br/>Detects <i>CE</i> [MEMOBUS/Modbus Error] and operates in accordance with <i>H5-04</i> [Communication Error Stop Method].</li> </ul> <p><b>Note:</b></p> <ul style="list-style-type: none"> <li>After the error detection, each drive can continue the operation specified by the last received command if allowed by the <i>F6-01</i> and <i>H5-04</i> settings. However, because the controller will not be able to stop the operation, a stopping means such as an emergency stop switch must be made available.</li> <li>If you set <i>H5-05</i> = 0 [CE Detection Selection = Disabled], CE will not be detected regardless of the <i>H5-04</i> setting.</li> </ul> |
| From communication option to master drive | oFAxx       | <ul style="list-style-type: none"> <li>Master drive<br/>Detects <i>oFAxx</i> and coasts to stop.</li> <li>Slave drive<br/>Detects <i>hLCE</i> [Error Sending to Controller] and coasts to stop.</li> </ul>   |
| From master drive to slave drive          | CE          | <p>The master drive stops communicating with the slave drive in question in the following cases. Reset the fault to restart communication. The slave drive detects CE after <i>H5-09</i> [CE Detection Time] is expired. Then it operates in accordance with <i>H5-04</i> [Communication Error Stop Method].</p> <ul style="list-style-type: none"> <li>Message error occurred in the send data from the slave drive 10 consecutive times.</li> <li>Response from the slave drive timed out 10 consecutive times.</li> </ul>   |

### Special Register for Gateway Mode

Table 2.52 Command Data

| Register No. (Hex.) | Description   |  |
|---------------------|---|--|
| 15C5                | Command Source Update   |  |
|                     | This flag enables command updates.  |  |
|                     | bit 0   | Drive 1 Update Command Enabled                           |
|                     | To input the Run command and frequency reference at the same time, change the bit value from 0 to 1 after you write all commands. |  |
|                     | bit 1   | Drive 2 Update Command Enabled                           |
|                     | bit 2   | Drive 3 Update Command Enabled                           |
|                     | bit 3   | Drive 4 Update Command Enabled                           |
| 15C6                | bit 4   | Update Register Access Command Enabled                   |
|                     | bit 5 - F   | Region Code  |
|                     | Run Command (Drive 1)   |  |
|                     | bit 0   | H5-12 = 0: FWD/Stop<br>0 = Stop<br>1 = Forward run       |
|                     |   | H5-12 = 1: Run/Stop<br>0 = Stop<br>1 = Run               |
|                     | bit 1   | H5-12 = 0: REV/Stop<br>0 = Stop<br>1 = Reverse run       |
|                     |   | H5-12 = 1: FWD/REV<br>0 = Forward run<br>1 = Reverse run |
|                     | bit 2   | External fault   |
|                     | bit 3   | Fault Reset Procedure                                    |
| bit 4               | ComRef  |  |
| bit 5               | ComCtrl   |  |
| bit 6 - F           | Region Code   |  |
| 15C7                | Frequency Reference (Drive 1)   | The unit of measure changes when <i>o1-03</i> changes.   |
| 15C8                | Run Command (Drive 2)   |  |
| 15C9                | Frequency Reference (Drive 2)   |  |
| 15CA                | Run Command (Drive 3)   |  |



| Register No. (Hex.) | Description                                |   |
|---------------------|--|---|
| 15CB                | Frequency Reference (Drive 3)              |   |
| 15CC                | Run Command (Drive 4)                      |   |
| 15CD                | Frequency Reference (Drive 4)              |   |
| 15CE                | Slave Address for Reg. Access + Read/Write |   |
|                     | bit 0                                      | Slave address<br>0: Broadcast Messages (MEMOBUS)<br>1: Drive 1<br>2: Drive 2<br>3: Drive 3<br>4: Drive 4<br>5: Broadcast Messages (Run command and frequency reference) |
|                     | bit 1                                      |   |
|                     | bit 2                                      |   |
|                     | bit 3                                      |   |
| bit 4               | 0: Read, 1: Write                          |   |
| bit 5 - F           | Region Code                                |   |
| 15CF                | Register No.                               |   |
| 15D0                | Data (write register)                      |   |

Table 2.53 Monitor Data

| Register No. (Hex.) | Description   |  |   |
|---------------------|---|--|---|
| 15E7                | Drive Status (Drive 1)  |  |   |
|                     | bit 0   | During Run   |   |
|                     | bit 1   | During Reverse Run                                     |   |
|                     | bit 2   | Drive ready  |   |
|                     | bit 3   | Faults   |   |
|                     | bit 4   | Frequency Command Setting Fault                        | 1: Upper/Lower Limit Fault  |
|                     | bit 5   | No response from slave                                 | 1: Response has timed out.  |
|                     | bit 6   | Communication Error                                    | 1: A fault has been detected from a slave.  |
|                     | bit 7   | No response from slave 10 consecutive attempts.        | 1: Timeout has occurred 10 consecutive times.                                     |
|                     | bit 8   | Communication fault has occurred 10 consecutive times. | 1: Fault has occurred from a slave 10 consecutive times.                          |
|                     | bit 9   | Receive broadcast command while drive is running       | 1: Drive operates as specified by the broadcast message command.                  |
|                     | bit A   | Communication error with master drive                  | 1: The slave cannot communicate with the master because of a communication error. |
|                     | bit B - D   | Region Code  |   |
|                     | bit E   | ComRef status  |   |
| bit F               | ComCtrl status  |  |   |
| 15E8                | Output frequency or frequency reference (Drive Status bit 4: ON) (Drive 1)<br>Drive Status Bit 4 = 0 [Output Frequency]<br>Drive Status Bit 4 = 1 [Frequency Reference] | The unit of measure changes when <i>o1-03</i> changes. |   |
| 15E9                | Drive Status (Drive 2)  |  |   |
| 15EA                | Output frequency or frequency reference (Drive Status bit 4: ON) (Drive 2)  |  |   |
| 15EB                | Drive Status (Drive 3)  |  |   |
| 15EC                | Output frequency or frequency reference (Drive Status bit 4: ON) (Drive 3)  |  |   |
| 15ED                | Drive Status (Drive 4)  |  |   |
| 15EE                | Output frequency or frequency reference (Drive Status bit 4: ON) (Drive 4)  |  |   |

## 2.7 F: Options

| Register No. (Hex.) | Description   |   |
|---------------------|---|---|
| 15EF                | Slave Address for Reg. Access + During MEMOBUS process & ErrCode  |   |
|                     | bit 0   | 00H: MEMOBUS communication complete                         |
|                     | bit 1   | 02H: Register number not registered                         |
|                     | bit 2   | 21H: Upper/Lower Limit Fault                                |
|                     | bit 3   | 22H: Writing Mode Error                                     |
|                     | bit 4   | 23H: Write performed during occurrence of $U_v$             |
|                     | bit 5   | 24H: Write performed while writing parameter settings       |
|                     | bit 6   | FFH: MEMOBUS communication in process                       |
|                     | bit 7   |   |
|                     | <b>Note:</b><br>If you change the access command before the MEMOBUS/Modbus access completion flag turns on, the drive will not execute the command from before. |   |
|                     | Slave address   |   |
|                     | bit 8   | 0: MEMOBUS command ignored                                  |
|                     | bit 9   | 1: Drive 1  |
|                     | bit A   | 2: Drive 2  |
|                     | bit B   | 3: Drive 3  |
|                     |   | 4: Drive 4  |
|                     |   | 5: Broadcast Messages (Run command and frequency reference) |
|                     | bit C - F   | Region Code   |
| 15F0                | Register No.  |   |
| 15F1                | Data (write register)   |   |

### ■ F6-01: Communication Error Selection

| No. (Hex.)   | Name                          | Description   | Default (Range) |
|--------------|-------------------------------|---|-----------------|
| F6-01 (03A2) | Communication Error Selection | <div style="display: flex; justify-content: space-between; align-items: center;"> <span>V/f</span> <span>CL-V/f</span> <span>OLV</span> <span>CLV</span> <span>AOLV</span> <span>OLV/PM</span> <span>AOLV/PM</span> <span>CLV/PM</span> <span>EZOLV</span> </div> Sets the method to stop the motor or let the motor continue operating when the drive detects a <i>bUS</i> [Option Communication Error]. | 1<br>(0 - 5)    |

#### 0 : Ramp to Stop

The drive ramps the motor to stop in the deceleration time. Fault relay output terminal MA-MC turns ON, and MB-MC turns OFF.

#### 1 : Coast to Stop

The output turns off and the motor coasts to stop. Fault relay output terminal MA-MC turns ON, and MB-MC turns OFF.

#### 2 : Fast Stop

The drive stops the motor in the deceleration time set in *C1-09* [Fast Stop Time]. Fault relay output terminal MA-MC turns ON, and MB-MC turns OFF.

#### 3 : Alarm Only

The keypad shows *bUS* and the drive continues operation at the current frequency reference.

**Note:**

Separately prepare safety protection equipment and systems, for example fast stop switches.

The output terminal set for *Alarm* [*H2-01* to *H2-03* = 10] turns ON.

#### 4 : Alarm (Run at d1-04)

The keypad shows *bUS* and the drive continues operation at the speed set in *d1-04* [Reference 4].

**Note:**

Separately prepare safety protection equipment and systems, for example fast stop switches.

#### 5 : Alarm - Ramp Stop

The drive stops the motor during the deceleration time set in *C1-02* [Deceleration Time 1].

After you remove the *bUS* alarm, the motor will accelerate to the previous frequency reference.

### ■ F6-02: Comm External Fault (EF0) Detect

| No. (Hex.)   | Name                             | Description   | Default (Range) |
|--------------|----------------------------------|---|-----------------|
| F6-02 (03A3) | Comm External Fault (EF0) Detect | <input type="checkbox"/> V/f <input type="checkbox"/> CL-V/f <input type="checkbox"/> OLV <input type="checkbox"/> CLV <input type="checkbox"/> AOLV <input type="checkbox"/> OLV/PM <input type="checkbox"/> AOLV/PM <input type="checkbox"/> CLV/PM <input type="checkbox"/> EZOLV<br>Sets the conditions at which <i>EF0</i> [Option Card External Fault] is detected. | 0<br>(0, 1)     |

**0 : Always Detected**

**1 : Detected during RUN Only**

### ■ F6-03: Comm External Fault (EF0) Select

| No. (Hex.)   | Name                             | Description  | Default (Range) |
|--------------|----------------------------------|--|-----------------|
| F6-03 (03A4) | Comm External Fault (EF0) Select | <input type="checkbox"/> V/f <input type="checkbox"/> CL-V/f <input type="checkbox"/> OLV <input type="checkbox"/> CLV <input type="checkbox"/> AOLV <input type="checkbox"/> OLV/PM <input type="checkbox"/> AOLV/PM <input type="checkbox"/> CLV/PM <input type="checkbox"/> EZOLV<br>Sets the method to stop the motor or let the motor continue operating when the drive detects an <i>EF0</i> [Option Card External Fault]. | 1<br>(0 - 3)    |

**0 : Ramp to Stop**

The drive ramps the motor to stop in the deceleration time. Fault relay output terminal MA-MC turns ON, and MB-MC turns OFF.

**1 : Coast to Stop**

The output turns off and the motor coasts to stop. Fault relay output terminal MA-MC turns ON, and MB-MC turns OFF.

**2 : Fast Stop**

The drive stops the motor in the deceleration time set in *C1-09* [Fast Stop Time]. Fault relay output terminal MA-MC turns ON, and MB-MC turns OFF.

**3 : Alarm Only**

The keypad shows *EF0* and the drive continues operation.

**Note:**

Separately prepare safety protection equipment and systems, for example fast stop switches.

The output terminal set for *Alarm* [H2-01 to H2-03 = 10] turns ON.

### ■ F6-04: bUS Error Detection Time

| No. (Hex.)   | Name                     | Description  | Default (Range)        |
|--------------|--------------------------|--|------------------------|
| F6-04 (03A5) | bUS Error Detection Time | <input type="checkbox"/> V/f <input type="checkbox"/> CL-V/f <input type="checkbox"/> OLV <input type="checkbox"/> CLV <input type="checkbox"/> AOLV <input type="checkbox"/> OLV/PM <input type="checkbox"/> AOLV/PM <input type="checkbox"/> CLV/PM <input type="checkbox"/> EZOLV<br>Sets the delay time for the drive to detect <i>bUS</i> [Option Communication Error]. | 2.0 s<br>(0.0 - 5.0 s) |

**Note:**

When you install an option card in the drive, the parameter value changes to 0.0 s.

### ■ F6-06: Torque Reference/Limit by Comm

| No. (Hex.)   | Name                           | Description   | Default (Range) |
|--------------|--------------------------------|---|-----------------|
| F6-06 (03A7) | Torque Reference/Limit by Comm | <input type="checkbox"/> V/f <input type="checkbox"/> CL-V/f <input type="checkbox"/> OLV <input type="checkbox"/> CLV <input type="checkbox"/> AOLV <input type="checkbox"/> OLV/PM <input type="checkbox"/> AOLV/PM <input type="checkbox"/> CLV/PM <input type="checkbox"/> EZOLV<br>Sets the function that enables and disables the torque reference and torque limit received from the communication option. | 0<br>(0, 1)     |

**0 : Disabled**

**1 : Enabled**

## 2.7 F: Options

### ■ F6-07: Multi-Step Ref @ NetRef/ComRef

| No.<br>(Hex.)   | Name                               | Description  | Default<br>(Range) |
|-----------------|------------------------------------|--|--------------------|
| F6-07<br>(03A8) | Multi-Step Ref @ NetRef/<br>ComRef | <b>V/f</b> <b>CL-V/f</b> <b>OLV</b> <b>CLV</b> <b>AOLV</b> <b>OLV/PM</b> <b>AOLV/PM</b> <b>CLV/PM</b> <b>EZOLV</b><br>Sets the function that enables and disables the multi-step speed reference when the frequency reference source is NetRef or ComRef (communication option card or MEMOBUS/Modbus communications). | 0<br>(0, 1)        |

#### 0 : Disable Multi-Step References

When NetRef or ComRef are the frequency reference source, the multi-step speed reference (2-step speed to 16-step speed references) and the Jog Frequency Reference (JOG command) are disabled.

#### 1 : Enable Multi-Step References

When NetRef or ComRef are the frequency reference source, the multi-step speed reference (2-step speed through 16-step speed references) and the Jog Frequency Reference (JOG command) are enabled, and you can change the frequency reference.

### ■ F6-08: Comm Parameter Reset @Initialize

| No.<br>(Hex.)   | Name                                | Description   | Default<br>(Range) |
|-----------------|-------------------------------------|---|--------------------|
| F6-08<br>(036A) | Comm Parameter Reset<br>@Initialize | <b>V/f</b> <b>CL-V/f</b> <b>OLV</b> <b>CLV</b> <b>AOLV</b> <b>OLV/PM</b> <b>AOLV/PM</b> <b>CLV/PM</b> <b>EZOLV</b><br>Sets the function to initialize <i>F6-xx</i> and <i>F7-xx</i> parameters when the drive is initialized with <i>A1-03</i> [Initialize Parameters]. | 0<br>(0, 1)        |

#### 0 : No Reset - Parameters Retained

#### 1 : Reset Back to Factory Default

##### Note:

When you use *A1-03* to initialize the drive, this setting will not change.

### ■ F6-10: CC-Link Node Address

| No.<br>(Hex.)   | Name                 | Description  | Default<br>(Range) |
|-----------------|----------------------|--|--------------------|
| F6-10<br>(03B6) | CC-Link Node Address | <b>V/f</b> <b>CL-V/f</b> <b>OLV</b> <b>CLV</b> <b>AOLV</b> <b>OLV/PM</b> <b>AOLV/PM</b> <b>CLV/PM</b> <b>EZOLV</b><br>Sets the node address for CC-Link communication. Restart the drive after changing the parameter setting. | 0<br>(0 - 64)      |

##### Note:

Be sure to set a node address that is different than all other node addresses. Do not set this parameter to 0. Incorrect parameter settings will cause *Aer* [Station Address Setting Error] errors and the L.ERR LED on the option will come on.

When the only drive is connected, you can connect a maximum of 42 nodes. Follow these rules to connect devices that are not drives:

- $\{(1 \times a) + (2 \times b) + (3 \times c) + (4 \times d)\} \leq 64$   
(a: number of units that occupies 1 node, b: number of units that occupies 2 nodes, c: number of units that occupies 3 nodes, d: number of units that occupies 4 nodes)
- $\{(16 \times A) + (54 \times B) + (88 \times C)\} \leq 2304$   
(A: number of remote I/O nodes (64 max.), B: number of remote device nodes (42 max.), C: number of local nodes (26 max.))

### ■ F6-11: CC-Link Communication Speed

| No.<br>(Hex.)   | Name                           | Description   | Default<br>(Range) |
|-----------------|--------------------------------|---|--------------------|
| F6-11<br>(03B7) | CC-Link Communication<br>Speed | <b>V/f</b> <b>CL-V/f</b> <b>OLV</b> <b>CLV</b> <b>AOLV</b> <b>OLV/PM</b> <b>AOLV/PM</b> <b>CLV/PM</b> <b>EZOLV</b><br>Sets the communication speed for CC-Link communication. Restart the drive after changing the parameter setting. | 0<br>(0 - 4)       |

#### 0 : 156 kbps

#### 1 : 625 kbps

#### 2 : 2.5 Mbps

3 : 5 Mbps

4 : 10 Mbps

### ■ F6-14: BUS Error Auto Reset

| No. (Hex.)      | Name                 | Description   | Default (Range) |
|-----------------|----------------------|---|-----------------|
| F6-14<br>(03BB) | BUS Error Auto Reset | <b>V/f</b> <b>CL-V/f</b> <b>OLV</b> <b>CLV</b> <b>AOLV</b> <b>OLV/PM</b> <b>AOLV/PM</b> <b>CLV/PM</b> <b>EZOLV</b><br>Sets the automatic reset function for <i>bUS</i> [Option Communication Errors]. | 0<br>(0, 1)     |

0 : Disabled

1 : Enabled

### ■ F6-15: Communication Option Parameter Reload

| No. (Hex.)      | Name                                  | Description  | Default (Range) |
|-----------------|---------------------------------------|--|-----------------|
| F6-15<br>(0B5B) | Communication Option Parameter Reload | <b>V/f</b> <b>CL-V/f</b> <b>OLV</b> <b>CLV</b> <b>AOLV</b> <b>OLV/PM</b> <b>AOLV/PM</b> <b>CLV/PM</b> <b>EZOLV</b><br>Sets the update method when <i>F6-xx</i> , <i>F7-xx</i> [Communication Options] are changed. | 0<br>(0 - 2)    |

**Note:**

- Set *F6-15* = 0, 1 to reload *F6-xx*, *F7-xx*.
- Set *F6-15* = 0, 1 to reset the display on the keypad to 0.

0 : It is updated when the power turns on again.

The changed parameters will be updated when you restart the drive.

1 : Update immediately

The changed parameters will be updated without restarting the drive.

2 : Cancel update

Cancels *CyPo* [Update when power turns on again].

### ■ F6-16: Gateway Mode

| No. (Hex.)      | Name         | Description   | Default (Range) |
|-----------------|--------------|---|-----------------|
| F6-16<br>(0B8A) | Gateway Mode | <b>V/f</b> <b>CL-V/f</b> <b>OLV</b> <b>CLV</b> <b>AOLV</b> <b>OLV/PM</b> <b>AOLV/PM</b> <b>CLV/PM</b> <b>EZOLV</b><br>Sets the gateway mode operation and the number of connected slave drives. | 0<br>(0 to 4)   |

0 : Disabled

1 : Enabled: 1 Slave Drives

2 : Enabled: 2 Slave Drives

3 : Enabled: 3 Slave Drives

4 : Enabled: 4 Slave Drives

### ■ F6-20: MECHATROLINK Station Address

| No. (Hex.)      | Name                         | Description  | Default (Range)   |
|-----------------|------------------------------|--|---|
| F6-20<br>(036B) | MECHATROLINK Station Address | <b>V/f</b> <b>CL-V/f</b> <b>OLV</b> <b>CLV</b> <b>AOLV</b> <b>OLV/PM</b> <b>AOLV/PM</b> <b>CLV/PM</b> <b>EZOLV</b><br>Sets the station address for MECHATROLINK communication. Restart the drive after changing the parameter setting. | 0021h<br>(MECHATROLINK-II:<br>0020h - 003Fh,<br>MECHATROLINK-III:<br>0003h - 00EFh) |

**Note:**

- The setting range changes if using MECHATROLINK-II or MECHATROLINK-III:
  - MECHATROLINK-II (SI-T3) range: 20 to 3F
  - MECHATROLINK-III (SI-ET3) range: 03 to EF
- Be sure to set a node address that is different than all other node addresses. Incorrect parameter settings will cause *AEr* [Station Address Setting Error] errors and the L.ERR LED on the option will come on.
- The drive detects *AEr* errors when the station address is 20 or 3F.

## 2.7 F: Options

### ■ F6-21: MECHATROLINK Frame Size

| No. (Hex.)   | Name                    | Description   | Default (Range) |
|--------------|-------------------------|---|-----------------|
| F6-21 (036C) | MECHATROLINK Frame Size | <b>V/f</b> <b>CL-V/f</b> <b>OLV</b> <b>CLV</b> <b>AOLV</b> <b>OLV/PM</b> <b>AOLV/PM</b> <b>CLV/PM</b> <b>EZOLV</b><br>Sets the frame size for MECHATROLINK communication. Restart the drive after changing the parameter setting. | 0<br>(0, 1)     |

**0 : 32byte (M-2) / 64byte (M-3)**

**1 : 17byte (M-2) / 32byte (M-3)**

### ■ F6-22: MECHATROLINK Link Speed

| No. (Hex.)   | Name                    | Description  | Default (Range) |
|--------------|-------------------------|--|-----------------|
| F6-22 (036D) | MECHATROLINK Link Speed | <b>V/f</b> <b>CL-V/f</b> <b>OLV</b> <b>CLV</b> <b>AOLV</b> <b>OLV/PM</b> <b>AOLV/PM</b> <b>CLV/PM</b> <b>EZOLV</b><br>Sets the communications speed for MECHATROLINK-II. Restart the drive after changing the parameter setting. | 0<br>(0, 1)     |

Note:

This parameter is only available with the MECHATROLINK-II option.

**0 : 10 Mbps**

**1 : 4 Mbps**

### ■ F6-23: MECHATROLINK Monitor Select (E)

| No. (Hex.)   | Name                            | Description  | Default (Range)          |
|--------------|---------------------------------|--|--------------------------|
| F6-23 (036E) | MECHATROLINK Monitor Select (E) | <b>V/f</b> <b>CL-V/f</b> <b>OLV</b> <b>CLV</b> <b>AOLV</b> <b>OLV/PM</b> <b>AOLV/PM</b> <b>CLV/PM</b> <b>EZOLV</b><br>Sets the MEMOBUS register used for the monitor functions of INV_CTL (drive operation control command) and INV_I/O (drive I/O control command). Restart the drive after changing the parameter setting. | 0000h<br>(0000h - FFFFh) |

To enable the MEMOBUS register set in *F6-23*, set SEL\_MON2/1 to 0EH or set SEL\_MON 3/4 and SEL\_MON 5/6 to 0EH. Bytes of the response data enable the MEMOBUS register content that was set in *F6-23*.

### ■ F6-24: MECHATROLINK Monitor Select (F)

| No. (Hex.)   | Name                            | Description  | Default (Range)          |
|--------------|---------------------------------|--|--------------------------|
| F6-24 (036F) | MECHATROLINK Monitor Select (F) | <b>V/f</b> <b>CL-V/f</b> <b>OLV</b> <b>CLV</b> <b>AOLV</b> <b>OLV/PM</b> <b>AOLV/PM</b> <b>CLV/PM</b> <b>EZOLV</b><br>Sets the MEMOBUS register used for the monitor functions of INV_CTL (drive operation control command) and INV_I/O (drive I/O control command). Restart the drive after changing the parameter setting. | 0000h<br>(0000h - FFFFh) |

To enable the MEMOBUS register set in *F6-24*, set SEL\_MON2/1 to 0FH or set SEL\_MON3/4 and SEL\_MON 5/6 to 0FH. Bytes of the response data enable the MEMOBUS register content that was set *F6-24*.

### ■ F6-25: MECHATROLINK Watchdog Error Sel

| No. (Hex.)   | Name                            | Description  | Default (Range) |
|--------------|---------------------------------|--|-----------------|
| F6-25 (03C9) | MECHATROLINK Watchdog Error Sel | <b>V/f</b> <b>CL-V/f</b> <b>OLV</b> <b>CLV</b> <b>AOLV</b> <b>OLV/PM</b> <b>AOLV/PM</b> <b>CLV/PM</b> <b>EZOLV</b><br>Sets the method to stop the motor or let the motor continue operating when the drive detects an <i>E5</i> [MECHATROLINK Watchdog Timer Err]. | 1<br>(0 - 3)    |

**0 : Ramp to Stop**

The drive ramps the motor to stop in the deceleration time. Fault relay output terminal MA-MC turns ON, and MB-MC turns OFF.

**1 : Coast to Stop**

The output turns off and the motor coasts to stop. Fault relay output terminal MA-MC turns ON, and MB-MC turns OFF.

**2 : Fast Stop**

The drive stops the motor in the deceleration time set in *C1-09 [Fast Stop Time]*. Fault relay output terminal MA-MC turns ON, and MB-MC turns OFF.

### 3 : Alarm Only

The keypad shows *E5*, and the drive continues to operate.

#### Note:

Separately prepare safety protection equipment and systems, for example fast stop switches.

The output terminal set for *Alarm [H2-01 to H2-03 = 10]* turns ON.

### ■ F6-26: MECHATROLINK Allowable No of Err

| No. (Hex.)   | Name                             | Description  | Default (Range)     |
|--------------|----------------------------------|--|---------------------|
| F6-26 (03CA) | MECHATROLINK Allowable No of Err | <b>V/f</b> <b>CL-V/f</b> <b>OLV</b> <b>CLV</b> <b>AOLV</b> <b>OLV/PM</b> <b>AOLV/PM</b> <b>CLV/PM</b> <b>EZOLV</b><br>Sets the number of times that the option must detect a <i>bUS</i> alarm to cause a <i>bUS [Option Communication Error]</i> . | 2<br>(2 - 10 times) |

### ■ F6-30: PROFIBUS-DP Node Address

| No. (Hex.)   | Name                     | Description  | Default (Range) |
|--------------|--------------------------|--|-----------------|
| F6-30 (03CB) | PROFIBUS-DP Node Address | <b>V/f</b> <b>CL-V/f</b> <b>OLV</b> <b>CLV</b> <b>AOLV</b> <b>OLV/PM</b> <b>AOLV/PM</b> <b>CLV/PM</b> <b>EZOLV</b><br>Sets the node address for PROFIBUS-DP communication. Restart the drive after changing the parameter setting. | 0<br>(0 - 125)  |

#### Note:

- Be sure to set a node address that is different than all other node addresses.
- Node addresses 0, 1, and 2 are usually reserved for control, maintenance, and device self-diagnosis.

### ■ F6-31: PROFIBUS-DP Clear Mode Selection

| No. (Hex.)   | Name                             | Description   | Default (Range) |
|--------------|----------------------------------|---|-----------------|
| F6-31 (03CC) | PROFIBUS-DP Clear Mode Selection | <b>V/f</b> <b>CL-V/f</b> <b>OLV</b> <b>CLV</b> <b>AOLV</b> <b>OLV/PM</b> <b>AOLV/PM</b> <b>CLV/PM</b> <b>EZOLV</b><br>Sets what the drive will do after it receives the Clear Mode command. | 0<br>(0, 1)     |

### 0 : Reset

Resets drive settings, for example frequency reference and I/O settings.

### 1 : Hold Previous State

The drive keeps the same status as before it received the command.

### ■ F6-32: PROFIBUS-DP Data Format Select

| No. (Hex.)   | Name                           | Description  | Default (Range) |
|--------------|--------------------------------|--|-----------------|
| F6-32 (03CD) | PROFIBUS-DP Data Format Select | <b>V/f</b> <b>CL-V/f</b> <b>OLV</b> <b>CLV</b> <b>AOLV</b> <b>OLV/PM</b> <b>AOLV/PM</b> <b>CLV/PM</b> <b>EZOLV</b><br>Sets the data format of PROFIBUS-DP communication. Restart the drive after changing the parameter setting. | 0<br>(0 - 5)    |

#### Note:

The *H5-11 [Comm ENTER Command Mode]* setting makes the RAM enter command necessary or not necessary to write parameters over network communication. When *F6-32 = 0, 1, or 2*, the *H5-11* setting does not have an effect. The RAM enter command is always necessary to write parameters.

### 0 : PPO Type

#### 1 : Conventional

#### 2 : PPO (bit0)

This function operates when bit 0 and bit 4 in the register STW have values of 1 (operate). Refer to the PROFIBUS-DP communication manual for more information.

#### 3 : PPO (Enter)

#### 4 : Conventional (Enter)

## 2.7 F: Options

### 5 : PPO (bit0, Enter)

This function operates when bit 0 and bit 4 in the register STW have values of 1 (operate). Refer to the PROFIBUS-DP communication manual for more information.

### ■ F6-35: CANopen Node ID Selection

| No.<br>(Hex.)   | Name                      | Description  | Default<br>(Range) |
|-----------------|---------------------------|--|--------------------|
| F6-35<br>(03D0) | CANopen Node ID Selection | <b>V/f</b> <b>CL-V/f</b> <b>OLV</b> <b>CLV</b> <b>AOLV</b> <b>OLV/PM</b> <b>AOLV/PM</b> <b>CLV/PM</b> <b>EZOLV</b><br>Sets the node address for CANopen communication. Restart the drive after changing the parameter setting. | 0<br>(0 - 126)     |

**Note:**

Be sure to set an address that is different than all other node addresses. Do not set this parameter to 0. Incorrect parameter settings will cause *AEr [Station Address Setting Error]* errors and the L.ERR LED on the option will come on.

### ■ F6-36: CANopen Communication Speed

| No.<br>(Hex.)   | Name                        | Description  | Default<br>(Range) |
|-----------------|-----------------------------|--|--------------------|
| F6-36<br>(03D1) | CANopen Communication Speed | <b>V/f</b> <b>CL-V/f</b> <b>OLV</b> <b>CLV</b> <b>AOLV</b> <b>OLV/PM</b> <b>AOLV/PM</b> <b>CLV/PM</b> <b>EZOLV</b><br>Sets the CANopen communications speed. Restart the drive after changing the parameter setting. | 6<br>(0 - 8)       |

### 0 : Auto-detection

The drive detects the network communication speed and automatically adjusts the communications speed.

**1 : 10 kbps**

**2 : 20 kbps**

**3 : 50 kbps**

**4 : 125 kbps**

**5 : 250 kbps**

**6 : 500 kbps**

**7 : 800 kbps**

**8 : 1 Mbps**

### ■ F6-45: BACnet Node Address

| No.<br>(Hex.)   | Name                | Description   | Default<br>(Range) |
|-----------------|---------------------|---|--------------------|
| F6-45<br>(02FB) | BACnet Node Address | <b>V/f</b> <b>CL-V/f</b> <b>OLV</b> <b>CLV</b> <b>AOLV</b> <b>OLV/PM</b> <b>AOLV/PM</b> <b>CLV/PM</b> <b>EZOLV</b><br>Sets the node address for BACnet communication. | 1<br>(0 - 127)     |

### ■ F6-46: BACnet Baud Rate

| No.<br>(Hex.)   | Name             | Description   | Default<br>(Range) |
|-----------------|------------------|---|--------------------|
| F6-46<br>(02FC) | BACnet Baud Rate | <b>V/f</b> <b>CL-V/f</b> <b>OLV</b> <b>CLV</b> <b>AOLV</b> <b>OLV/PM</b> <b>AOLV/PM</b> <b>CLV/PM</b> <b>EZOLV</b><br>Sets the BACnet communications speed. | 3<br>(0 - 8)       |

**0 : 1200 bps**

**1 : 2400 bps**

**2 : 4800 bps**

**3 : 9600 bps**

**4 : 19.2 kbps**

**5 : 38.4 kbps**

**6 : 57.6 kbps**

**7 : 76.8 kbps**

**8 : 115.2 kbps**



### ■ F6-47: Rx to Tx Wait Time

| No. (Hex.)   | Name               | Description  | Default (Range)     |
|--------------|--------------------|--|---------------------|
| F6-47 (02FD) | Rx to Tx Wait Time | <b>V/f</b> <b>CL-V/f</b> <b>OLV</b> <b>CLV</b> <b>AOLV</b> <b>OLV/PM</b> <b>AOLV/PM</b> <b>CLV/PM</b> <b>EZOLV</b><br>Sets the wait time for the drive to receive and send BACnet communication. | 5 ms<br>(5 - 65 ms) |

### ■ F6-48: BACnet Device Object Identifier0

| No. (Hex.)   | Name                             | Description   | Default (Range) |
|--------------|----------------------------------|---|-----------------|
| F6-48 (02FE) | BACnet Device Object Identifier0 | <b>V/f</b> <b>CL-V/f</b> <b>OLV</b> <b>CLV</b> <b>AOLV</b> <b>OLV/PM</b> <b>AOLV/PM</b> <b>CLV/PM</b> <b>EZOLV</b><br>Sets the last word of BACnet communication addresses. | 0<br>(0 - FFFF) |

### ■ F6-49: BACnet Device Object Identifier1

| No. (Hex.)   | Name                             | Description   | Default (Range) |
|--------------|----------------------------------|---|-----------------|
| F6-49 (02FF) | BACnet Device Object Identifier1 | <b>V/f</b> <b>CL-V/f</b> <b>OLV</b> <b>CLV</b> <b>AOLV</b> <b>OLV/PM</b> <b>AOLV/PM</b> <b>CLV/PM</b> <b>EZOLV</b><br>Sets the last word of BACnet communication addresses. | 0<br>(0 - 3F)   |

### ■ F6-50: DeviceNet MAC Address

| No. (Hex.)   | Name                  | Description   | Default (Range) |
|--------------|-----------------------|---|-----------------|
| F6-50 (03C1) | DeviceNet MAC Address | <b>V/f</b> <b>CL-V/f</b> <b>OLV</b> <b>CLV</b> <b>AOLV</b> <b>OLV/PM</b> <b>AOLV/PM</b> <b>CLV/PM</b> <b>EZOLV</b><br>Sets the MAC address for DeviceNet communication. Restart the drive after changing the parameter setting. | 64<br>(0 - 64)  |

**Note:**

Be sure to set a MAC address that is different than all other node addresses. Do not set this parameter to 0. Incorrect parameter settings will cause *Aer* [Station Address Setting Error] errors and the MS LED on the option will flash.

### ■ F6-51: DeviceNet Baud Rate

| No. (Hex.)   | Name                | Description  | Default (Range) |
|--------------|---------------------|--|-----------------|
| F6-51 (03C2) | DeviceNet Baud Rate | <b>V/f</b> <b>CL-V/f</b> <b>OLV</b> <b>CLV</b> <b>AOLV</b> <b>OLV/PM</b> <b>AOLV/PM</b> <b>CLV/PM</b> <b>EZOLV</b><br>Sets the DeviceNet communications speed. Restart the drive after changing the parameter setting. | 4<br>(0 - 4)    |

**0 : 125 kbps**

**1 : 250 kbps**

**2 : 500 kbps**

**3 : Adjustable from Network**

The controller sets the communications speed.

**4 : Detect Automatically**

The drive detects the network communication speed and automatically adjusts the communications speed.

### ■ F6-52: DeviceNet PCA Setting

| No. (Hex.)   | Name                  | Description   | Default (Range) |
|--------------|-----------------------|---|-----------------|
| F6-52 (03C3) | DeviceNet PCA Setting | <b>V/f</b> <b>CL-V/f</b> <b>OLV</b> <b>CLV</b> <b>AOLV</b> <b>OLV/PM</b> <b>AOLV/PM</b> <b>CLV/PM</b> <b>EZOLV</b><br>Sets the format of data that the DeviceNet communication master sends to the drive. | 21<br>(0 - 255) |

**Note:**

If F6-52 [DeviceNet PCA Setting] and F6-53 [DeviceNet PPA Setting] are not correct, the value is reset to default.

## 2.7 F: Options

### ■ F6-53: DeviceNet PPA Setting

| No.<br>(Hex.)   | Name                  | Description   | Default<br>(Range) |
|-----------------|-----------------------|---|--------------------|
| F6-53<br>(03C4) | DeviceNet PPA Setting | <b>V/f</b> <b>CL-V/f</b> <b>OLV</b> <b>CLV</b> <b>AOLV</b> <b>OLV/PM</b> <b>AOLV/PM</b> <b>CLV/PM</b> <b>EZOLV</b><br>Sets the format of data that the drive sends to the DeviceNet communication master. | 71<br>(0 - 255)    |

**Note:**

If F6-52 [DeviceNet PCA Setting] and F6-53 [DeviceNet PPA Setting] are not correct, the value is reset to default.

### ■ F6-54: DeviceNet Idle Fault Detection

| No.<br>(Hex.)   | Name                           | Description   | Default<br>(Range) |
|-----------------|--------------------------------|---|--------------------|
| F6-54<br>(03C5) | DeviceNet Idle Fault Detection | <b>V/f</b> <b>CL-V/f</b> <b>OLV</b> <b>CLV</b> <b>AOLV</b> <b>OLV/PM</b> <b>AOLV/PM</b> <b>CLV/PM</b> <b>EZOLV</b><br>Sets the function to detect <i>EF0</i> [Option Card External Fault] when the drive does not receive data from the DeviceNet master. | 0<br>(0 - 4)       |

**0 : Enabled**

**1 : Disabled, No Fault Detection**

Does not detect *EF0* issues.

**2 : Vendor Specific**

**3 : RUN Forward**

**4 : RUN Reverse**

### ■ F6-55: DeviceNet Baud Rate Monitor

| No.<br>(Hex.)   | Name                        | Description  | Default<br>(Range) |
|-----------------|-----------------------------|--|--------------------|
| F6-55<br>(03C6) | DeviceNet Baud Rate Monitor | <b>V/f</b> <b>CL-V/f</b> <b>OLV</b> <b>CLV</b> <b>AOLV</b> <b>OLV/PM</b> <b>AOLV/PM</b> <b>CLV/PM</b> <b>EZOLV</b><br>Sets the function to see the actual DeviceNet communications speed using the keypad. This parameter functions as a monitor only. | 0<br>(0 - 2)       |

**0 : 125 kbps**

**1 : 250 kbps**

**2 : 500 kbps**

### ■ F6-56: DeviceNet Speed Scaling

| No.<br>(Hex.)   | Name                    | Description   | Default<br>(Range) |
|-----------------|-------------------------|---|--------------------|
| F6-56<br>(03D7) | DeviceNet Speed Scaling | <b>V/f</b> <b>CL-V/f</b> <b>OLV</b> <b>CLV</b> <b>AOLV</b> <b>OLV/PM</b> <b>AOLV/PM</b> <b>CLV/PM</b> <b>EZOLV</b><br>Sets the speed scale for DeviceNet communication. | 0<br>(-15 - +15)   |

### ■ F6-57: DeviceNet Current Scaling

| No.<br>(Hex.)   | Name                      | Description   | Default<br>(Range) |
|-----------------|---------------------------|---|--------------------|
| F6-57<br>(03D8) | DeviceNet Current Scaling | <b>V/f</b> <b>CL-V/f</b> <b>OLV</b> <b>CLV</b> <b>AOLV</b> <b>OLV/PM</b> <b>AOLV/PM</b> <b>CLV/PM</b> <b>EZOLV</b><br>Sets the current scale of the DeviceNet communication master. | 0<br>(-15 - +15)   |

### ■ F6-58: DeviceNet Torque Scaling

| No.<br>(Hex.)   | Name                     | Description  | Default<br>(Range) |
|-----------------|--------------------------|--|--------------------|
| F6-58<br>(03D9) | DeviceNet Torque Scaling | <b>V/f</b> <b>CL-V/f</b> <b>OLV</b> <b>CLV</b> <b>AOLV</b> <b>OLV/PM</b> <b>AOLV/PM</b> <b>CLV/PM</b> <b>EZOLV</b><br>Sets the torque scale of the DeviceNet communication master. | 0<br>(-15 - +15)   |

### ■ F6-59: DeviceNet Power Scaling

| No. (Hex.)      | Name                    | Description   | Default (Range)  |
|-----------------|-------------------------|---|------------------|
| F6-59<br>(03DA) | DeviceNet Power Scaling | <b>V/f</b> <b>CL-V/f</b> <b>OLV</b> <b>CLV</b> <b>AOLV</b> <b>OLV/PM</b> <b>AOLV/PM</b> <b>CLV/PM</b> <b>EZOLV</b><br>Sets the power scale of the DeviceNet communication master. | 0<br>(-15 - +15) |

### ■ F6-60: DeviceNet Voltage Scaling

| No. (Hex.)      | Name                      | Description   | Default (Range)  |
|-----------------|---------------------------|---|------------------|
| F6-60<br>(03DB) | DeviceNet Voltage Scaling | <b>V/f</b> <b>CL-V/f</b> <b>OLV</b> <b>CLV</b> <b>AOLV</b> <b>OLV/PM</b> <b>AOLV/PM</b> <b>CLV/PM</b> <b>EZOLV</b><br>Sets the voltage scale of the DeviceNet communication master. | 0<br>(-15 - +15) |

### ■ F6-61: DeviceNet Time Scaling

| No. (Hex.)      | Name                   | Description  | Default (Range)  |
|-----------------|------------------------|--|------------------|
| F6-61<br>(03DC) | DeviceNet Time Scaling | <b>V/f</b> <b>CL-V/f</b> <b>OLV</b> <b>CLV</b> <b>AOLV</b> <b>OLV/PM</b> <b>AOLV/PM</b> <b>CLV/PM</b> <b>EZOLV</b><br>Sets the time scale of the DeviceNet communication master. | 0<br>(-15 - +15) |

### ■ F6-62: DeviceNet Heartbeat Interval

| No. (Hex.)      | Name                         | Description  | Default (Range) |
|-----------------|------------------------------|--|-----------------|
| F6-62<br>(03DD) | DeviceNet Heartbeat Interval | <b>V/f</b> <b>CL-V/f</b> <b>OLV</b> <b>CLV</b> <b>AOLV</b> <b>OLV/PM</b> <b>AOLV/PM</b> <b>CLV/PM</b> <b>EZOLV</b><br>Sets the heartbeat for DeviceNet communication. Set this parameter to 0 to disable the heartbeat function. | 0<br>(0 - 10)   |

### ■ F6-63: DeviceNet Network MAC ID

| No. (Hex.)      | Name                     | Description   | Default (Range) |
|-----------------|--------------------------|---|-----------------|
| F6-63<br>(03DE) | DeviceNet Network MAC ID | <b>V/f</b> <b>CL-V/f</b> <b>OLV</b> <b>CLV</b> <b>AOLV</b> <b>OLV/PM</b> <b>AOLV/PM</b> <b>CLV/PM</b> <b>EZOLV</b><br>Sets the function to see the actual DeviceNet MAC address using the keypad. This parameter functions as a monitor only. | 63<br>(0 - 63)  |

### ■ F6-64 to F6-67: Dynamic Out Assembly 109 Param1 to 4

| No. (Hex.)                      | Name                                  | Description   | Default (Range)          |
|---------------------------------|---------------------------------------|---|--------------------------|
| F6-64 to F6-67<br>(03DF – 03E2) | Dynamic Out Assembly 109 Param 1 to 4 | <b>V/f</b> <b>CL-V/f</b> <b>OLV</b> <b>CLV</b> <b>AOLV</b> <b>OLV/PM</b> <b>AOLV/PM</b> <b>CLV/PM</b> <b>EZOLV</b><br>Sets Configurable Outputs 1 to 4 written to the MEMOBUS register. | 0000h<br>(0000h - FFFFh) |

### ■ F6-68 to F6-71: Dynamic In Assembly 159 Param 1 to 4

| No. (Hex.)                                     | Name                                 | Description  | Default (Range)          |
|--|--------------------------------------|--|--------------------------|
| F6-68 to F6-71<br>(03E3, 03E4, 03C7, and 03C8) | Dynamic In Assembly 159 Param 1 to 4 | <b>V/f</b> <b>CL-V/f</b> <b>OLV</b> <b>CLV</b> <b>AOLV</b> <b>OLV/PM</b> <b>AOLV/PM</b> <b>CLV/PM</b> <b>EZOLV</b><br>Sets Configurable Inputs 1 to 4 written to the MEMOBUS register. | 0000h<br>(0000h - FFFFh) |

### ■ F6-72: PowerLink Node Address

| No. (Hex.)      | Name                   | Description   | Default (Range) |
|-----------------|------------------------|---|-----------------|
| F6-72<br>(081B) | PowerLink Node Address | <b>V/f</b> <b>CL-V/f</b> <b>OLV</b> <b>CLV</b> <b>AOLV</b> <b>OLV/PM</b> <b>AOLV/PM</b> <b>CLV/PM</b> <b>EZOLV</b><br>Sets the node ID for PowerLink communication. | 0<br>(0 - 255)  |

## 2.7 F: Options

### ■ F7-01: IP Address 1

| No.<br>(Hex.)   | Name         | Description   | Default<br>(Range) |
|-----------------|--------------|---|--------------------|
| F7-01<br>(03E5) | IP Address 1 | <b>V/f</b> <b>CL-V/f</b> <b>OLV</b> <b>CLV</b> <b>AOLV</b> <b>OLV/PM</b> <b>AOLV/PM</b> <b>CLV/PM</b> <b>EZOLV</b><br>Sets the first octet of the IP Address for the device that is connecting to the network. Restart the drive after you change this parameter. | 192<br>(0 - 255)   |

**Note:**

When  $F7-13 = 0$  [Address Mode at Startup = Static]:

- Use parameters  $F7-01$  to  $F7-04$  [IP Address 4] to set the IP Address. Be sure to set a different IP address for each drive on the network.
- Also set parameters  $F7-01$  to  $F7-12$ .

### ■ F7-02: IP Address 2

| No.<br>(Hex.)   | Name         | Description  | Default<br>(Range) |
|-----------------|--------------|--|--------------------|
| F7-02<br>(03E6) | IP Address 2 | <b>V/f</b> <b>CL-V/f</b> <b>OLV</b> <b>CLV</b> <b>AOLV</b> <b>OLV/PM</b> <b>AOLV/PM</b> <b>CLV/PM</b> <b>EZOLV</b><br>Sets the second octet of the IP Address for the device that is connecting to the network. Restart the drive after you change this parameter. | 168<br>(0 - 255)   |

**Note:**

When  $F7-13 = 0$  [Address Mode at Startup = Static]:

- Use parameters  $F7-01$  to  $F7-04$  [IP Address 4] to set the IP Address. Be sure to set a different IP address for each drive on the network.
- Also set parameters  $F7-01$  to  $F7-12$ .

### ■ F7-03: IP Address 3

| No.<br>(Hex.)   | Name         | Description   | Default<br>(Range) |
|-----------------|--------------|---|--------------------|
| F7-03<br>(03E7) | IP Address 3 | <b>V/f</b> <b>CL-V/f</b> <b>OLV</b> <b>CLV</b> <b>AOLV</b> <b>OLV/PM</b> <b>AOLV/PM</b> <b>CLV/PM</b> <b>EZOLV</b><br>Sets the third octet of the IP Address for the device that is connecting to the network. Restart the drive after you change this parameter. | 1<br>(0 - 255)     |

**Note:**

When  $F7-13 = 0$  [Address Mode at Startup = Static]:

- Use parameters  $F7-01$  to  $F7-04$  [IP Address 4] to set the IP Address. Be sure to set a different IP address for each drive on the network.
- Also set parameters  $F7-01$  to  $F7-12$ .

### ■ F7-04: IP Address 4

| No.<br>(Hex.)   | Name         | Description  | Default<br>(Range) |
|-----------------|--------------|--|--------------------|
| F7-04<br>(03E8) | IP Address 4 | <b>V/f</b> <b>CL-V/f</b> <b>OLV</b> <b>CLV</b> <b>AOLV</b> <b>OLV/PM</b> <b>AOLV/PM</b> <b>CLV/PM</b> <b>EZOLV</b><br>Sets the fourth octet of the IP Address for the device that is connecting to the network. Restart the drive after you change this parameter. | 20<br>(0 - 255)    |

**Note:**

When  $F7-13 = 0$  [Address Mode at Startup = Static]:

- Use parameters  $F7-01$  to  $F7-04$  [IP Address 4] to set the IP Address. Be sure to set a different IP address for each drive on the network.
- Also set parameters  $F7-01$  to  $F7-12$ .

### ■ F7-05: Subnet Mask 1

| No.<br>(Hex.)   | Name          | Description   | Default<br>(Range) |
|-----------------|---------------|---|--------------------|
| F7-05<br>(03E9) | Subnet Mask 1 | <b>V/f</b> <b>CL-V/f</b> <b>OLV</b> <b>CLV</b> <b>AOLV</b> <b>OLV/PM</b> <b>AOLV/PM</b> <b>CLV/PM</b> <b>EZOLV</b><br>Sets the first octet of the subnet mask of the connected network. | 255<br>(0 - 255)   |

**Note:**

Set this parameter when  $F7-13 = 0$  [Address Mode at Startup = Static].

### ■ F7-06: Subnet Mask 2

| No.<br>(Hex.)   | Name          | Description  | Default<br>(Range) |
|-----------------|---------------|--|--------------------|
| F7-06<br>(03EA) | Subnet Mask 2 | <b>V/f</b> <b>CL-V/f</b> <b>OLV</b> <b>CLV</b> <b>AOLV</b> <b>OLV/PM</b> <b>AOLV/PM</b> <b>CLV/PM</b> <b>EZOLV</b><br>Sets the second octet of the subnet mask of the connected network. | 255<br>(0 - 255)   |

**Note:**

Set this parameter when  $F7-13 = 0$  [Address Mode at Startup = Static].

### ■ F7-07: Subnet Mask 3

| No.<br>(Hex.)   | Name          | Description   | Default<br>(Range) |
|-----------------|---------------|---|--------------------|
| F7-07<br>(03EB) | Subnet Mask 3 | <b>V/f</b> <b>CL-V/f</b> <b>OLV</b> <b>CLV</b> <b>AOLV</b> <b>OLV/PM</b> <b>AOLV/PM</b> <b>CLV/PM</b> <b>EZOLV</b><br>Sets the third octet of the subnet mask of the connected network. | 255<br>(0 - 255)   |

**Note:**

Set this parameter when  $F7-13 = 0$  [Address Mode at Startup = Static].

### ■ F7-08: Subnet Mask 4

| No.<br>(Hex.)   | Name          | Description  | Default<br>(Range) |
|-----------------|---------------|--|--------------------|
| F7-08<br>(03EC) | Subnet Mask 4 | <b>V/f</b> <b>CL-V/f</b> <b>OLV</b> <b>CLV</b> <b>AOLV</b> <b>OLV/PM</b> <b>AOLV/PM</b> <b>CLV/PM</b> <b>EZOLV</b><br>Sets the fourth octet of the subnet mask of the connected network. | 0<br>(0 - 255)     |

**Note:**

Set this parameter when  $F7-13 = 0$  [Address Mode at Startup = Static].

### ■ F7-09: Gateway Address 1

| No.<br>(Hex.)   | Name              | Description   | Default<br>(Range) |
|-----------------|-------------------|---|--------------------|
| F7-09<br>(03ED) | Gateway Address 1 | <b>V/f</b> <b>CL-V/f</b> <b>OLV</b> <b>CLV</b> <b>AOLV</b> <b>OLV/PM</b> <b>AOLV/PM</b> <b>CLV/PM</b> <b>EZOLV</b><br>Sets the first octet of the gateway address of the connected network. | 192<br>(0 - 255)   |

**Note:**

Set this parameter when  $F7-13 = 0$  [Address Mode at Startup = Static].

### ■ F7-10: Gateway Address 2

| No.<br>(Hex.)   | Name              | Description  | Default<br>(Range) |
|-----------------|-------------------|--|--------------------|
| F7-10<br>(03EE) | Gateway Address 2 | <b>V/f</b> <b>CL-V/f</b> <b>OLV</b> <b>CLV</b> <b>AOLV</b> <b>OLV/PM</b> <b>AOLV/PM</b> <b>CLV/PM</b> <b>EZOLV</b><br>Sets the second octet of the gateway address of the connected network. | 168<br>(0 - 255)   |

**Note:**

Set this parameter when  $F7-13 = 0$  [Address Mode at Startup = Static].

### ■ F7-11: Gateway Address 3

| No.<br>(Hex.)   | Name              | Description   | Default<br>(Range) |
|-----------------|-------------------|---|--------------------|
| F7-11<br>(03EF) | Gateway Address 3 | <b>V/f</b> <b>CL-V/f</b> <b>OLV</b> <b>CLV</b> <b>AOLV</b> <b>OLV/PM</b> <b>AOLV/PM</b> <b>CLV/PM</b> <b>EZOLV</b><br>Sets the third octet of the gateway address of the connected network. | 1<br>(0 - 255)     |

**Note:**

Set this parameter when  $F7-13 = 0$  [Address Mode at Startup = Static].

## 2.7 F: Options

### ■ F7-12: Gateway Address 4

| No.<br>(Hex.)   | Name              | Description  | Default<br>(Range) |
|-----------------|-------------------|--|--------------------|
| F7-12<br>(03F0) | Gateway Address 4 | <b>V/f</b> <b>CL-V/f</b> <b>OLV</b> <b>CLV</b> <b>AOLV</b> <b>OLV/PM</b> <b>AOLV/PM</b> <b>CLV/PM</b> <b>EZOLV</b><br>Sets the fourth octet of the gateway address of the connected network. | 1<br>(0 - 255)     |

**Note:**

Set this parameter when *F7-13 = 0* [Address Mode at Startup = Static].

### ■ F7-13: Address Mode at Startup

| No.<br>(Hex.)   | Name                    | Description  | Default<br>(Range) |
|-----------------|-------------------------|--|--------------------|
| F7-13<br>(03F1) | Address Mode at Startup | <b>V/f</b> <b>CL-V/f</b> <b>OLV</b> <b>CLV</b> <b>AOLV</b> <b>OLV/PM</b> <b>AOLV/PM</b> <b>CLV/PM</b> <b>EZOLV</b><br>Sets the method to set option card IP addresses. | 2<br>(0 - 2)       |

**0 : Static**

**1 : BOOTP**

**2 : DHCP**

**Note:**

- The following setting values are available when using the PROFINET communication option card (SI-EP3).  
–0: Static  
–2: DCP
- When *F7-13 = 0*, set parameters *F7-01 to F7-12* [IP Address 1 to Gateway Address 4] to set the IP Address. Be sure to set a different IP address for each drive on the network.

### ■ F7-14: Duplex Mode Selection

| No.<br>(Hex.)   | Name                  | Description  | Default<br>(Range) |
|-----------------|-----------------------|--|--------------------|
| F7-14<br>(03F2) | Duplex Mode Selection | <b>V/f</b> <b>CL-V/f</b> <b>OLV</b> <b>CLV</b> <b>AOLV</b> <b>OLV/PM</b> <b>AOLV/PM</b> <b>CLV/PM</b> <b>EZOLV</b><br>Sets the duplex mode setting method. | 1<br>(0 - 8)       |

**0 : Half/Half**

**1 : Auto/Auto**

**2 : Full/Full**

**3 : Half/Auto**

Port 1 is set to “Half” and port 2 is set to “Auto”.

**4 : Half/Full**

Port 1 is set to “Half” and port 2 is set to “Full”.

**5 : Auto/Half**

Port 1 is set to “Auto” and port 2 is set to “Half”.

**6 : Auto/Full**

Port 1 is set to “Auto” and port 2 is set to “Full”.

**7 : Full/Half**

Port 1 is set to “Full” and port 2 is set to “Half”.

**8 : Full/Auto**

Port 1 is set to “Full” and port 2 is set to “Auto”.

### ■ F7-15: Communication Speed Selection

| No.<br>(Hex.)   | Name                          | Description  | Default<br>(Range)    |
|-----------------|-------------------------------|--|-----------------------|
| F7-15<br>(03F3) | Communication Speed Selection | <b>V/f</b> <b>CL-V/f</b> <b>OLV</b> <b>CLV</b> <b>AOLV</b> <b>OLV/PM</b> <b>AOLV/PM</b> <b>CLV/PM</b> <b>EZOLV</b><br>Sets the communications speed. | 10<br>(10, 100 - 102) |

10 : 10/10 Mbps  
 100 : 100/100 Mbps  
 101 : 10/100 Mbps  
 102 : 100/10 Mbps

**Note:**

Set this parameter when  $F7-14 = 0$  or  $2$  [Duplex Mode Selection = Half/Half or Full/Full].

### ■ F7-16: Timeout Value

| No.<br>(Hex.)   | Name          | Description   | Default<br>(Range)      |
|-----------------|---------------|---|-------------------------|
| F7-16<br>(03F4) | Timeout Value | <b>V/f</b> <b>CL-V/f</b> <b>OLV</b> <b>CLV</b> <b>AOLV</b> <b>OLV/PM</b> <b>AOLV/PM</b> <b>CLV/PM</b> <b>EZOLV</b><br>Sets the detection time for a communications timeout. | 0.0 s<br>(0.0 - 30.0 s) |

**Note:**

Set this parameter to 0.0 to disable the connection timeout function.

### ■ F7-17: EtherNet/IP Speed Scaling Factor

| No.<br>(Hex.)   | Name                             | Description   | Default<br>(Range) |
|-----------------|----------------------------------|---|--------------------|
| F7-17<br>(03F5) | EtherNet/IP Speed Scaling Factor | <b>V/f</b> <b>CL-V/f</b> <b>OLV</b> <b>CLV</b> <b>AOLV</b> <b>OLV/PM</b> <b>AOLV/PM</b> <b>CLV/PM</b> <b>EZOLV</b><br>Sets the scaling factor for the speed monitor in the EtherNet/IP Class ID 2AH Object. | 0<br>(-15 - +15)   |

### ■ F7-18: EtherNet/IP Current Scale Factor

| No.<br>(Hex.)   | Name                             | Description  | Default<br>(Range) |
|-----------------|----------------------------------|--|--------------------|
| F7-18<br>(03F6) | EtherNet/IP Current Scale Factor | <b>V/f</b> <b>CL-V/f</b> <b>OLV</b> <b>CLV</b> <b>AOLV</b> <b>OLV/PM</b> <b>AOLV/PM</b> <b>CLV/PM</b> <b>EZOLV</b><br>Sets the scaling factor for the output current monitor in the EtherNet/IP Class ID 2AH Object. | 0<br>(-15 - +15)   |

### ■ F7-19: EtherNet/IP Torque Scale Factor

| No.<br>(Hex.)   | Name                            | Description  | Default<br>(Range) |
|-----------------|---------------------------------|--|--------------------|
| F7-19<br>(03F7) | EtherNet/IP Torque Scale Factor | <b>V/f</b> <b>CL-V/f</b> <b>OLV</b> <b>CLV</b> <b>AOLV</b> <b>OLV/PM</b> <b>AOLV/PM</b> <b>CLV/PM</b> <b>EZOLV</b><br>Sets the scaling factor for the torque monitor in the EtherNet/IP Class ID 2AH Object. | 0<br>(-15 - +15)   |

### ■ F7-20: EtherNet/IP Power Scaling Factor

| No.<br>(Hex.)   | Name                             | Description   | Default<br>(Range) |
|-----------------|----------------------------------|---|--------------------|
| F7-20<br>(03F8) | EtherNet/IP Power Scaling Factor | <b>V/f</b> <b>CL-V/f</b> <b>OLV</b> <b>CLV</b> <b>AOLV</b> <b>OLV/PM</b> <b>AOLV/PM</b> <b>CLV/PM</b> <b>EZOLV</b><br>Sets the scaling factor for the power monitor in the EtherNet/IP Class ID 2AH Object. | 0<br>(-15 - +15)   |

### ■ F7-21: EtherNet/IP Voltage Scale Factor

| No.<br>(Hex.)   | Name                             | Description   | Default<br>(Range) |
|-----------------|----------------------------------|---|--------------------|
| F7-21<br>(03F9) | EtherNet/IP Voltage Scale Factor | <b>V/f</b> <b>CL-V/f</b> <b>OLV</b> <b>CLV</b> <b>AOLV</b> <b>OLV/PM</b> <b>AOLV/PM</b> <b>CLV/PM</b> <b>EZOLV</b><br>Sets the scaling factor for the voltage monitor in the EtherNet/IP Class ID 2AH Object. | 0<br>(-15 - +15)   |

### ■ F7-22: EtherNet/IP Time Scaling

| No.<br>(Hex.)   | Name                     | Description  | Default<br>(Range) |
|-----------------|--------------------------|--|--------------------|
| F7-22<br>(03FA) | EtherNet/IP Time Scaling | <b>V/f</b> <b>CL-V/f</b> <b>OLV</b> <b>CLV</b> <b>AOLV</b> <b>OLV/PM</b> <b>AOLV/PM</b> <b>CLV/PM</b> <b>EZOLV</b><br>Sets the scaling factor for the time monitor in the EtherNet/IP Class ID 2AH Object. | 0<br>(-15 - +15)   |

## 2.7 F: Options

### ■ F7-23 to F7-32: Dynamic Out Param 1 to 10 for CommCard

| No. (Hex.)   | Name                                   | Description  | Default (Range) |
|--|--|--|-----------------|
| F7-23 - F7-27 (03FB - 03FF)<br>F7-28 - F7-32 (0370 - 0374) | Dynamic Out Param 1 to 10 for CommCard | <b>V/f</b> <b>CL-V/f</b> <b>OLV</b> <b>CLV</b> <b>AOLV</b> <b>OLV/PM</b> <b>AOLV/PM</b> <b>CLV/PM</b> <b>EZOLV</b><br>Sets Output Assembly 116. The drive writes the values from Output Assembly 116 to the MEMOBUS/Modbus address register that is stored for each parameter. The drive will not write the values from Output Assembly 116 to the registers when the MEMOBUS/Modbus address is 0. | 0               |

### ■ F7-33 to F7-42: Dynamic In Param 1 to 10 for CommCard

| No. (Hex.)                  | Name                                  | Description   | Default (Range) |
|-----------------------------|---------------------------------------|---|-----------------|
| F7-33 - F7-42 (0375 - 037E) | Dynamic In Param 1 to 10 for CommCard | <b>V/f</b> <b>CL-V/f</b> <b>OLV</b> <b>CLV</b> <b>AOLV</b> <b>OLV/PM</b> <b>AOLV/PM</b> <b>CLV/PM</b> <b>EZOLV</b><br>Sets Input Assembly 166. The drive sends the values from the MEMOBUS/Modbus address registers stored for each parameter to Input Assembly 166. The drive returns the default register value for the option card when the MEMOBUS/Modbus address is 0 and the value sent to Input Assembly 166 is not defined. | 0               |

### ■ F7-60: PZD1 Write (Control Word)

| No. (Hex.)   | Name                      | Description  | Default (Range) |
|--------------|---------------------------|--|-----------------|
| F7-60 (0780) | PZD1 Write (Control Word) | <b>V/f</b> <b>CL-V/f</b> <b>OLV</b> <b>CLV</b> <b>AOLV</b> <b>OLV/PM</b> <b>AOLV/PM</b> <b>CLV/PM</b> <b>EZOLV</b><br>Sets the MEMOBUS/Modbus address for PZD1 (PPO output). PZD1 (PPO output) functions as the STW when <i>F7-60 = 0, 1, or 2</i> . | 0               |

### ■ F7-61: PZD2 Write (Frequency Reference)

| No. (Hex.)   | Name                             | Description  | Default (Range) |
|--------------|----------------------------------|--|-----------------|
| F7-61 (0781) | PZD2 Write (Frequency Reference) | <b>V/f</b> <b>CL-V/f</b> <b>OLV</b> <b>CLV</b> <b>AOLV</b> <b>OLV/PM</b> <b>AOLV/PM</b> <b>CLV/PM</b> <b>EZOLV</b><br>Sets the MEMOBUS/Modbus address for PZD2 (PPO output). PZD2 (PPO output) functions as the HSW when <i>F7-61 = 0, 1, or 2</i> . | 0               |

### ■ F7-62: PZD3 Write

| No. (Hex.)   | Name       | Description   | Default (Range) |
|--------------|------------|---|-----------------|
| F7-62 (0782) | PZD3 Write | <b>V/f</b> <b>CL-V/f</b> <b>OLV</b> <b>CLV</b> <b>AOLV</b> <b>OLV/PM</b> <b>AOLV/PM</b> <b>CLV/PM</b> <b>EZOLV</b><br>Sets the MEMOBUS/Modbus address for PZD3 (PPO output). A value of 0, 1, or 2 will disable the PZD3 (PPO output) write operation to the MEMOBUS/Modbus register. | 0               |

### ■ F7-63: PZD4 Write

| No. (Hex.)   | Name       | Description   | Default (Range) |
|--------------|------------|---|-----------------|
| F7-63 (0783) | PZD4 Write | <b>V/f</b> <b>CL-V/f</b> <b>OLV</b> <b>CLV</b> <b>AOLV</b> <b>OLV/PM</b> <b>AOLV/PM</b> <b>CLV/PM</b> <b>EZOLV</b><br>Sets the MEMOBUS/Modbus address for PZD4 (PPO output). A value of 0, 1, or 2 will disable the PZD4 (PPO output) write operation to the MEMOBUS/Modbus register. | 0               |

### ■ F7-64: PZD5 Write

| No. (Hex.)   | Name       | Description   | Default (Range) |
|--------------|------------|---|-----------------|
| F7-64 (0784) | PZD5 Write | <b>V/f</b> <b>CL-V/f</b> <b>OLV</b> <b>CLV</b> <b>AOLV</b> <b>OLV/PM</b> <b>AOLV/PM</b> <b>CLV/PM</b> <b>EZOLV</b><br>Sets the MEMOBUS/Modbus address for PZD5 (PPO output). A value of 0, 1, or 2 will disable the PZD5 (PPO output) write operation to the MEMOBUS/Modbus register. | 0               |



### ■ F7-65: PZD6 Write

| No. (Hex.)   | Name       | Description   | Default (Range) |
|--------------|------------|---|-----------------|
| F7-65 (0785) | PZD6 Write | <div style="display: flex; justify-content: space-between; gap: 5px;"> <span>V/f</span> <span>CL-V/f</span> <span>OLV</span> <span>CLV</span> <span>AOLV</span> <span>OLV/PM</span> <span>AOLV/PM</span> <span>CLV/PM</span> <span>EZOLV</span> </div> <p>Sets the MEMOBUS/Modbus address for PZD6 (PPO output). A value of 0, 1, or 2 will disable the PZD6 (PPO output) write operation to the MEMOBUS/Modbus register.</p> | 0               |

### ■ F7-66: PZD7 Write

| No. (Hex.)   | Name       | Description   | Default (Range) |
|--------------|------------|---|-----------------|
| F7-66 (0786) | PZD7 Write | <div style="display: flex; justify-content: space-between; gap: 5px;"> <span>V/f</span> <span>CL-V/f</span> <span>OLV</span> <span>CLV</span> <span>AOLV</span> <span>OLV/PM</span> <span>AOLV/PM</span> <span>CLV/PM</span> <span>EZOLV</span> </div> <p>Sets the MEMOBUS/Modbus address for PZD7 (PPO output). A value of 0, 1, or 2 will disable the PZD7 (PPO output) write operation to the MEMOBUS/Modbus register.</p> | 0               |

### ■ F7-67: PZD8 Write

| No. (Hex.)   | Name       | Description   | Default (Range) |
|--------------|------------|---|-----------------|
| F7-67 (0787) | PZD8 Write | <div style="display: flex; justify-content: space-between; gap: 5px;"> <span>V/f</span> <span>CL-V/f</span> <span>OLV</span> <span>CLV</span> <span>AOLV</span> <span>OLV/PM</span> <span>AOLV/PM</span> <span>CLV/PM</span> <span>EZOLV</span> </div> <p>Sets the MEMOBUS/Modbus address for PZD8 (PPO output). A value of 0, 1, or 2 will disable the PZD8 (PPO output) write operation to the MEMOBUS/Modbus register.</p> | 0               |

### ■ F7-68: PZD9 Write

| No. (Hex.)   | Name       | Description   | Default (Range) |
|--------------|------------|---|-----------------|
| F7-68 (0788) | PZD9 Write | <div style="display: flex; justify-content: space-between; gap: 5px;"> <span>V/f</span> <span>CL-V/f</span> <span>OLV</span> <span>CLV</span> <span>AOLV</span> <span>OLV/PM</span> <span>AOLV/PM</span> <span>CLV/PM</span> <span>EZOLV</span> </div> <p>Sets the MEMOBUS/Modbus address for PZD9 (PPO output). A value of 0, 1, or 2 will disable the PZD9 (PPO output) write operation to the MEMOBUS/Modbus register.</p> | 0               |

### ■ F7-69: PZD10 Write

| No. (Hex.)   | Name        | Description   | Default (Range) |
|--------------|-------------|---|-----------------|
| F7-69 (0789) | PZD10 Write | <div style="display: flex; justify-content: space-between; gap: 5px;"> <span>V/f</span> <span>CL-V/f</span> <span>OLV</span> <span>CLV</span> <span>AOLV</span> <span>OLV/PM</span> <span>AOLV/PM</span> <span>CLV/PM</span> <span>EZOLV</span> </div> <p>Sets the MEMOBUS/Modbus address for PZD10 (PPO output). A value of 0, 1, or 2 will disable the PZD10 (PPO output) write operation to the MEMOBUS/Modbus register.</p> | 0               |

### ■ F7-70: PZD1 Read (Status Word)

| No. (Hex.)   | Name                    | Description   | Default (Range) |
|--------------|-------------------------|---|-----------------|
| F7-70 (078A) | PZD1 Read (Status Word) | <div style="display: flex; justify-content: space-between; gap: 5px;"> <span>V/f</span> <span>CL-V/f</span> <span>OLV</span> <span>CLV</span> <span>AOLV</span> <span>OLV/PM</span> <span>AOLV/PM</span> <span>CLV/PM</span> <span>EZOLV</span> </div> <p>Sets the MEMOBUS/Modbus address for PZD1 (PPO Read). PZD1 (PPO input) functions as the ZSW when <i>F7-70 = 0</i>.</p> | 0               |

### ■ F7-71: PZD2 Read (Output Frequency)

| No. (Hex.)   | Name                         | Description   | Default (Range) |
|--------------|------------------------------|---|-----------------|
| F7-71 (078B) | PZD2 Read (Output Frequency) | <div style="display: flex; justify-content: space-between; gap: 5px;"> <span>V/f</span> <span>CL-V/f</span> <span>OLV</span> <span>CLV</span> <span>AOLV</span> <span>OLV/PM</span> <span>AOLV/PM</span> <span>CLV/PM</span> <span>EZOLV</span> </div> <p>Sets the MEMOBUS/Modbus address for PZD2 (PPO Read). PZD2 (PPO input) functions as the HIW when <i>F7-71 = 0</i>.</p> | 0               |

### ■ F7-72: PZD3 Read

| No. (Hex.)   | Name      | Description   | Default (Range) |
|--------------|-----------|---|-----------------|
| F7-72 (078C) | PZD3 Read | <div style="display: flex; justify-content: space-between; gap: 5px;"> <span>V/f</span> <span>CL-V/f</span> <span>OLV</span> <span>CLV</span> <span>AOLV</span> <span>OLV/PM</span> <span>AOLV/PM</span> <span>CLV/PM</span> <span>EZOLV</span> </div> <p>Sets the MEMOBUS/Modbus address for PZD3 (PPO Read). A value of 0 will disable the PZD3 (PPO Read) load operation from the MEMOBUS/Modbus register.</p> | 0               |

## 2.7 F: Options

### ■ F7-73: PZD4 Read

| No.<br>(Hex.)   | Name      | Description   | Default<br>(Range) |
|-----------------|-----------|---|--------------------|
| F7-73<br>(078D) | PZD4 Read | <div style="display: flex; gap: 5px;"> <span>V/f</span> <span>CL-V/f</span> <span>OLV</span> <span>CLV</span> <span>AOLV</span> <span>OLV/PM</span> <span>AOLV/PM</span> <span>CLV/PM</span> <span>EZOLV</span> </div> <p>Sets the MEMOBUS/Modbus address for PZD4 (PPO Read). A value of 0 will disable the PZD4 (PPO Read) load operation from the MEMOBUS/Modbus register.</p> | 0                  |

### ■ F7-74: PZD5 Read

| No.<br>(Hex.)   | Name      | Description   | Default<br>(Range) |
|-----------------|-----------|---|--------------------|
| F7-74<br>(078E) | PZD5 Read | <div style="display: flex; gap: 5px;"> <span>V/f</span> <span>CL-V/f</span> <span>OLV</span> <span>CLV</span> <span>AOLV</span> <span>OLV/PM</span> <span>AOLV/PM</span> <span>CLV/PM</span> <span>EZOLV</span> </div> <p>Sets the MEMOBUS/Modbus address for PZD5 (PPO Read). A value of 0 will disable the PZD5 (PPO Read) load operation from the MEMOBUS/Modbus register.</p> | 0                  |

### ■ F7-75: PZD6 Read

| No.<br>(Hex.)   | Name      | Description   | Default<br>(Range) |
|-----------------|-----------|---|--------------------|
| F7-75<br>(078F) | PZD6 Read | <div style="display: flex; gap: 5px;"> <span>V/f</span> <span>CL-V/f</span> <span>OLV</span> <span>CLV</span> <span>AOLV</span> <span>OLV/PM</span> <span>AOLV/PM</span> <span>CLV/PM</span> <span>EZOLV</span> </div> <p>Sets the MEMOBUS/Modbus address for PZD6 (PPO Read). A value of 0 will disable the PZD6 (PPO Read) load operation from the MEMOBUS/Modbus register.</p> | 0                  |

### ■ F7-76: PZD7 Read

| No.<br>(Hex.)   | Name      | Description  | Default<br>(Range) |
|-----------------|-----------|--|--------------------|
| F7-76<br>(0790) | PZD7 Read | <div style="display: flex; gap: 5px;"> <span>V/f</span> <span>CL-V/f</span> <span>OLV</span> <span>CLV</span> <span>AOLV</span> <span>OLV/PM</span> <span>AOLV/PM</span> <span>CLV/PM</span> <span>EZOLV</span> </div> <p>Sets the MEMOBUS/Modbus address for PZD7 (PPO Read). A value of 0 will disable the PZD7 (PPO input) load operation from the MEMOBUS/Modbus register.</p> | 0                  |

### ■ F7-77: PZD8 Read

| No.<br>(Hex.)   | Name      | Description   | Default<br>(Range) |
|-----------------|-----------|---|--------------------|
| F7-77<br>(0791) | PZD8 Read | <div style="display: flex; gap: 5px;"> <span>V/f</span> <span>CL-V/f</span> <span>OLV</span> <span>CLV</span> <span>AOLV</span> <span>OLV/PM</span> <span>AOLV/PM</span> <span>CLV/PM</span> <span>EZOLV</span> </div> <p>Sets the MEMOBUS/Modbus address for PZD8 (PPO Read). A value of 0 will disable the PZD8 (PPO Read) load operation from the MEMOBUS/Modbus register.</p> | 0                  |

### ■ F7-78: PZD9 Read

| No.<br>(Hex.)   | Name      | Description   | Default<br>(Range) |
|-----------------|-----------|---|--------------------|
| F7-78<br>(0792) | PZD9 Read | <div style="display: flex; gap: 5px;"> <span>V/f</span> <span>CL-V/f</span> <span>OLV</span> <span>CLV</span> <span>AOLV</span> <span>OLV/PM</span> <span>AOLV/PM</span> <span>CLV/PM</span> <span>EZOLV</span> </div> <p>Sets the MEMOBUS/Modbus address for PZD9 (PPO Read). A value of 0 will disable the PZD9 (PPO Read) load operation from the MEMOBUS/Modbus register.</p> | 0                  |

### ■ F7-79: PZD10 Read

| No.<br>(Hex.)   | Name       | Description   | Default<br>(Range) |
|-----------------|------------|---|--------------------|
| F7-79<br>(0793) | PZD10 Read | <div style="display: flex; gap: 5px;"> <span>V/f</span> <span>CL-V/f</span> <span>OLV</span> <span>CLV</span> <span>AOLV</span> <span>OLV/PM</span> <span>AOLV/PM</span> <span>CLV/PM</span> <span>EZOLV</span> </div> <p>Sets the MEMOBUS/Modbus address for PZD10 (PPO Read). A value of 0 will disable the PZD10 (PPO Read) load operation from the MEMOBUS/Modbus register.</p> | 0                  |

## 2.8 H: Terminal Functions

*H* parameters are used to assign functions to external input and output terminals.

### ◆ H1: Digital Inputs

*H1* Parameters set the MFDI terminal functions.

#### ■ H1-01 to H1-08 Terminal S1 to S8 Function Selection

The drive has 8 MFDI terminals. Refer to Table 2.54 for drive default settings and functions.

**Table 2.54 MFDI Default Settings and Functions**

| No.   | Name                           | Default   | Function                         |
|-------|--------------------------------|-----------|----------------------------------|
| H1-01 | Terminal S1 Function Selection | 40 (F) *1 | Forward RUN (2-Wire)             |
| H1-02 | Terminal S2 Function Selection | 41 (F) *1 | Reverse RUN (2-Wire)             |
| H1-03 | Terminal S3 Function Selection | 24        | External Fault (NO-Always-Coast) |
| H1-04 | Terminal S4 Function Selection | 14        | Fault Reset Procedure            |
| H1-05 | Terminal S5 Function Selection | 3 (0) *1  | Multi-Step Speed Reference 1     |
| H1-06 | Terminal S6 Function Selection | 4 (3) *1  | Multi-Step Speed Reference 2     |
| H1-07 | Terminal S7 Function Selection | 6 (4) *1  | Jog Reference Selection          |
| H1-08 | Terminal S8 Function Selection | 8         | Baseblock Command (N.O.)         |

\*1 The value in parentheses identifies the default setting when you set *A1-03* = 3330 [*Initialize Parameters = 3-Wire Initialization*]. Refer to Table 2.55 and use *H1-xx* [*MFDI Function Select*] to set the function.

**Table 2.55 MFDI Setting Values**

| Setting Value | Function                         | Reference | Setting Value | Function                        | Reference |
|---------------|----------------------------------|-----------|---------------|---------------------------------|-----------|
| 0 *1          | 3-Wire Sequence                  | 371       | 15 *1         | Fast Stop (N.O.)                | 378       |
| 1             | LOCAL/REMOTE Selection           | 372       | 16            | Motor 2 Selection               | 378       |
| 2             | External Reference 1/2 Selection | 372       | 17 *1         | Fast Stop (N.C.)                | 379       |
| 3             | Multi-Step Speed Reference 1     | 372       | 18            | Timer Function                  | 379       |
| 4             | Multi-Step Speed Reference 2     | 373       | 19            | PID Disable                     | 380       |
| 5             | Multi-Step Speed Reference 3     | 373       | 1A            | Accel/Decel Time Selection 2    | 380       |
| 6             | Jog Reference Selection          | 373       | 1B            | Programming Lockout             | 380       |
| 7             | Accel/Decel Time Selection 1     | 373       | 1E            | Reference Sample Hold           | 380       |
| 8 *1          | Baseblock Command (N.O.)         | 373       | 20 to 2F *1   | External fault                  | 381       |
| 9 *1          | Baseblock Command (N.C.)         | 374       | 30            | PID Integrator Reset            | 381       |
| A             | Accel/Decel Ramp Hold            | 374       | 31            | PID Integrator Hold             | 382       |
| B             | Overheat Alarm (oH2)             | 374       | 32            | Multi-Step Speed Reference 4    | 382       |
| C             | Analog Terminal Enable Selection | 374       | 34            | PID Soft Starter Disable        | 382       |
| D             | Ignore Speed Fdbk (V/f w/o Enc)  | 374       | 35            | PID Input (Error) Invert        | 382       |
| E             | ASR Integral Reset               | 374       | 3E            | PID Setpoint Selection 1        | 382       |
| F             | Through Mode                     | 375       | 3F            | PID Setpoint Selection 2        | 382       |
| 10            | Up Command                       | 375       | 40 *1         | Forward RUN (2-Wire)            | 383       |
| 11            | Down Command                     | 376       | 41 *1         | Reverse RUN (2-Wire)            | 383       |
| 12 *1         | Forward Jog                      | 377       | 42 *1         | Run Command (2-Wire Sequence 2) | 383       |
| 13 *1         | Reverse Jog                      | 377       | 43 *1         | FWD/REV (2-Wire Sequence 2)     | 383       |
| 14            | Fault Reset Procedure            | 378       | 44            | Add Offset Frequency 1 (d7-03)  | 384       |

## 2.8 H: Terminal Functions

| Setting Value | Function                        | Reference | Setting Value | Function  | Reference |
|---------------|---------------------------------|-----------|---------------|---|-----------|
| 45            | Add Offset Frequency 2 (d7-03)  | 384       | 75            | Up 2 Command  | 387       |
| 46            | Add Offset Frequency 3 (d7-03)  | 384       | 76            | Down 2 Command  | 388       |
| 47            | Node Setup (CANopen)            | 384       | 77            | ASR Gain (C5-03) Select   | 388       |
| 60            | DC Injection Braking Command    | 384       | 78            | Analog TorqueRef Polarity Invert  | 388       |
| 61            | Speed Search from Fmax          | 385       | 7A *1         | KEB Ride-Thru 2 Activate (N.C.)   | 389       |
| 62            | Speed Search from Fref          | 385       | 7B *1         | KEB Ride-Thru 2 Activate (N.O.)   | 389       |
| 63            | Field Weakening                 | 385       | 7C *1         | Short Circuit Braking (N.O.)  | 389       |
| 65 *1         | KEB Ride-Thru 1 Activate (N.C.) | 385       | 7D *1         | Short Circuit Braking (N.C.)  | 389       |
| 66 *1         | KEB Ride-Thru 1 Activate (N.O.) | 385       | 7E            | Reverse Rotation Identifier   | 390       |
| 67            | Communications Test Mode        | 386       | 90 to 97 *1   | DWEZ Digital Inputs 1 to 8  | 390       |
| 68            | High Slip Braking               | 386       | 9F            | DWEZ Disable  | 390       |
| 6A            | Drive Enable                    | 386       | 101 to 19F    | Inverse Input of 1 to 9F<br>Sets the function of the selected MFDI to operate inversely. To select the function for inverse input, enter two digits 01 to 9F for the "xx" in "1xx". | 390       |
| 71            | Torque Control                  | 386       |               |   |           |
| 72            | Zero Servo                      | 387       |               |   |           |

\*1 Inverse input is not available.

### ■ H1-01: Terminal S1 Function Selection

| No. (Hex.)   | Name                           | Description   | Default (Range) |
|--------------|--------------------------------|---|-----------------|
| H1-01 (0438) | Terminal S1 Function Selection | <input type="checkbox"/> V/f <input type="checkbox"/> CL-V/f <input type="checkbox"/> OLV <input type="checkbox"/> CLV <input type="checkbox"/> AOLV <input type="checkbox"/> OLV/PM <input type="checkbox"/> AOLV/PM <input type="checkbox"/> CLV/PM <input type="checkbox"/> EZOLV<br>Sets the function for MFDI terminal S1. | 40<br>(1 - 1FF) |

**Note:**

The default setting is *F* when the drive is initialized for *3-Wire Initialization* [A1-03 = 3330].

### ■ H1-02: Terminal S2 Function Selection

| No. (Hex.)   | Name                           | Description   | Default (Range) |
|--------------|--------------------------------|---|-----------------|
| H1-02 (0439) | Terminal S2 Function Selection | <input type="checkbox"/> V/f <input type="checkbox"/> CL-V/f <input type="checkbox"/> OLV <input type="checkbox"/> CLV <input type="checkbox"/> AOLV <input type="checkbox"/> OLV/PM <input type="checkbox"/> AOLV/PM <input type="checkbox"/> CLV/PM <input type="checkbox"/> EZOLV<br>Sets the function for MFDI terminal S2. | 41<br>(1 - 1FF) |

**Note:**

The default setting is *F* when the drive is initialized for *3-Wire Initialization* [A1-03 = 3330].

### ■ H1-03: Terminal S3 Function Selection

| No. (Hex.)   | Name                           | Description   | Default (Range) |
|--------------|--------------------------------|---|-----------------|
| H1-03 (0400) | Terminal S3 Function Selection | <input type="checkbox"/> V/f <input type="checkbox"/> CL-V/f <input type="checkbox"/> OLV <input type="checkbox"/> CLV <input type="checkbox"/> AOLV <input type="checkbox"/> OLV/PM <input type="checkbox"/> AOLV/PM <input type="checkbox"/> CLV/PM <input type="checkbox"/> EZOLV<br>Sets the function for MFDI terminal S3. | 24<br>(0 - 1FF) |

### ■ H1-04: Terminal S4 Function Selection

| No. (Hex.)   | Name                           | Description   | Default (Range) |
|--------------|--------------------------------|---|-----------------|
| H1-04 (0401) | Terminal S4 Function Selection | <input type="checkbox"/> V/f <input type="checkbox"/> CL-V/f <input type="checkbox"/> OLV <input type="checkbox"/> CLV <input type="checkbox"/> AOLV <input type="checkbox"/> OLV/PM <input type="checkbox"/> AOLV/PM <input type="checkbox"/> CLV/PM <input type="checkbox"/> EZOLV<br>Sets the function for MFDI terminal S4. | 14<br>(0 - 1FF) |

### ■ H1-05: Terminal S5 Function Selection

| No. (Hex.)   | Name                           | Description   | Default (Range) |
|--------------|--------------------------------|---|-----------------|
| H1-05 (0402) | Terminal S5 Function Selection | <input type="checkbox"/> V/f <input type="checkbox"/> CL-V/f <input type="checkbox"/> OLV <input type="checkbox"/> CLV <input type="checkbox"/> AOLV <input type="checkbox"/> OLV/PM <input type="checkbox"/> AOLV/PM <input type="checkbox"/> CLV/PM <input type="checkbox"/> EZOLV<br>Sets the function for MFDI terminal S5. | 3<br>(0 - 1FF)  |

**Note:**

The default setting is 0 when the drive is initialized for *3-Wire Initialization* [*A1-03 = 3330*].

**H1-06: Terminal S6 Function Selection**

| No. (Hex.)   | Name                           | Description   | Default (Range) |
|--------------|--------------------------------|---|-----------------|
| H1-06 (0403) | Terminal S6 Function Selection | <input type="checkbox"/> V/f <input type="checkbox"/> CL-V/f <input type="checkbox"/> OLV <input type="checkbox"/> CLV <input type="checkbox"/> AOLV <input type="checkbox"/> OLV/PM <input type="checkbox"/> AOLV/PM <input type="checkbox"/> CLV/PM <input type="checkbox"/> EZOLV<br>Sets the function for MFDI terminal S6. | 4<br>(0 - 1FF)  |

**Note:**

The default setting is 3 when the drive is initialized for *3-Wire Initialization* [*A1-03 = 3330*].

**H1-07: Terminal S7 Function Selection**

| No. (Hex.)   | Name                           | Description   | Default (Range) |
|--------------|--------------------------------|---|-----------------|
| H1-07 (0404) | Terminal S7 Function Selection | <input type="checkbox"/> V/f <input type="checkbox"/> CL-V/f <input type="checkbox"/> OLV <input type="checkbox"/> CLV <input type="checkbox"/> AOLV <input type="checkbox"/> OLV/PM <input type="checkbox"/> AOLV/PM <input type="checkbox"/> CLV/PM <input type="checkbox"/> EZOLV<br>Sets the function for MFDI terminal S7. | 6<br>(0 - 1FF)  |

**Note:**

The default setting is 4 when the drive is initialized for *3-Wire Initialization* [*A1-03 = 3330*].

**H1-08: Terminal S8 Function Selection**

| No. (Hex.)   | Name                           | Description   | Default (Range) |
|--------------|--------------------------------|---|-----------------|
| H1-08 (0405) | Terminal S8 Function Selection | <input type="checkbox"/> V/f <input type="checkbox"/> CL-V/f <input type="checkbox"/> OLV <input type="checkbox"/> CLV <input type="checkbox"/> AOLV <input type="checkbox"/> OLV/PM <input type="checkbox"/> AOLV/PM <input type="checkbox"/> CLV/PM <input type="checkbox"/> EZOLV<br>Sets the function for MFDI terminal S8. | 8<br>(0 - 1FF)  |

**H1-21: Terminal S1 Function Select 2**

| No. (Hex.)   | Name                             | Description  | Default (Range) |
|--------------|----------------------------------|--|-----------------|
| H1-21 (0B70) | Terminal S1 Function Selection 2 | <input type="checkbox"/> V/f <input type="checkbox"/> CL-V/f <input type="checkbox"/> OLV <input type="checkbox"/> CLV <input type="checkbox"/> AOLV <input type="checkbox"/> OLV/PM <input type="checkbox"/> AOLV/PM <input type="checkbox"/> CLV/PM <input type="checkbox"/> EZOLV<br>Sets the second function for MFDI terminal S1. | F<br>(1 - 19F)  |

When MFDI terminal S1 activates, it will operate the function set to *H1-01* [*Terminal S1 Function Selection*] and the function set to *H1-21* at the same time.

When the setting value is *F*, the function is disabled.

**H1-22: Terminal S2 Function Select 2**

| No. (Hex.)   | Name                          | Description  | Default (Range) |
|--------------|-------------------------------|--|-----------------|
| H1-22 (0B71) | Terminal S2 Function Select 2 | <input type="checkbox"/> V/f <input type="checkbox"/> CL-V/f <input type="checkbox"/> OLV <input type="checkbox"/> CLV <input type="checkbox"/> AOLV <input type="checkbox"/> OLV/PM <input type="checkbox"/> AOLV/PM <input type="checkbox"/> CLV/PM <input type="checkbox"/> EZOLV<br>Sets the second function for MFDI terminal S2. | F<br>(1 - 19F)  |

When MFDI terminal S2 activates, it will operate the function set to *H1-02* [*Terminal S2 Function Selection*] and the function set to *H1-22* at the same time.

When the setting value is *F*, the function is disabled.

**H1-23: Terminal S3 Function Select 2**

| No. (Hex.)   | Name                             | Description  | Default (Range) |
|--------------|----------------------------------|--|-----------------|
| H1-23 (0B72) | Terminal S3 Function Selection 2 | <input type="checkbox"/> V/f <input type="checkbox"/> CL-V/f <input type="checkbox"/> OLV <input type="checkbox"/> CLV <input type="checkbox"/> AOLV <input type="checkbox"/> OLV/PM <input type="checkbox"/> AOLV/PM <input type="checkbox"/> CLV/PM <input type="checkbox"/> EZOLV<br>Sets the second function for MFDI terminal S3. | F<br>(1 - 19F)  |

When MFDI terminal S3 activates, it will operate the function set to *H1-03* [*Terminal S3 Function Selection*] and the function set to *H1-23* at the same time.

When the setting value is *F*, the function is disabled.

## 2.8 H: Terminal Functions

### ■ H1-24: Terminal S4 Function Selection 2

| No.<br>(Hex.)   | Name                             | Description  | Default<br>(Range) |
|-----------------|----------------------------------|--|--------------------|
| H1-24<br>(0B73) | Terminal S4 Function Selection 2 | <b>V/f</b> <b>CL-V/f</b> <b>OLV</b> <b>CLV</b> <b>AOLV</b> <b>OLV/PM</b> <b>AOLV/PM</b> <b>CLV/PM</b> <b>EZOLV</b><br>Sets the second function for MFDI terminal S4. | F<br>(1 - 19F)     |

When MFDI terminal S4 activates, it will operate the function set to *H1-04 [Terminal S4 Function Selection]* and the function set to *H1-24* at the same time.

When the setting value is F, the function is disabled.

### ■ H1-25: Terminal S5 Function Select 2

| No.<br>(Hex.)   | Name                             | Description  | Default<br>(Range) |
|-----------------|----------------------------------|--|--------------------|
| H1-25<br>(0B74) | Terminal S5 Function Selection 2 | <b>V/f</b> <b>CL-V/f</b> <b>OLV</b> <b>CLV</b> <b>AOLV</b> <b>OLV/PM</b> <b>AOLV/PM</b> <b>CLV/PM</b> <b>EZOLV</b><br>Sets the second function for MFDI terminal S5. | F<br>(1 - 19F)     |

When MFDI terminal S5 activates, it will operate the function set to *H1-05 [Terminal S5 Function Selection]* and the function set to *H1-25* at the same time.

When the setting value is F, the function is disabled.

### ■ H1-26: Terminal S6 Function Select 2

| No.<br>(Hex.)   | Name                             | Description  | Default<br>(Range) |
|-----------------|----------------------------------|--|--------------------|
| H1-26<br>(0B75) | Terminal S6 Function Selection 2 | <b>V/f</b> <b>CL-V/f</b> <b>OLV</b> <b>CLV</b> <b>AOLV</b> <b>OLV/PM</b> <b>AOLV/PM</b> <b>CLV/PM</b> <b>EZOLV</b><br>Sets the second function for MFDI terminal S6. | F<br>(1 - 19F)     |

When MFDI terminal S6 activates, it will operate the function set to *H1-06 [Terminal S6 Function Selection]* and the function set to *H1-26* at the same time.

When the setting value is F, the function is disabled.

### ■ H1-27: Terminal S7 Function Select 2

| No.<br>(Hex.)   | Name                             | Description  | Default<br>(Range) |
|-----------------|----------------------------------|--|--------------------|
| H1-27<br>(0B76) | Terminal S7 Function Selection 2 | <b>V/f</b> <b>CL-V/f</b> <b>OLV</b> <b>CLV</b> <b>AOLV</b> <b>OLV/PM</b> <b>AOLV/PM</b> <b>CLV/PM</b> <b>EZOLV</b><br>Sets the second function for MFDI terminal S7. | F<br>(1 - 19F)     |

When MFDI terminal S7 activates, it will operate the function set to *H1-07 [Terminal S7 Function Selection]* and the function set to *H1-27* at the same time.

When the setting value is F, the function is disabled.

### ■ H1-28: Terminal S8 Function Select 2

| No.<br>(Hex.)   | Name                             | Description  | Default<br>(Range) |
|-----------------|----------------------------------|--|--------------------|
| H1-28<br>(0B77) | Terminal S8 Function Selection 2 | <b>V/f</b> <b>CL-V/f</b> <b>OLV</b> <b>CLV</b> <b>AOLV</b> <b>OLV/PM</b> <b>AOLV/PM</b> <b>CLV/PM</b> <b>EZOLV</b><br>Sets the second function for MFDI terminal S8. | F<br>(1 - 19F)     |

When MFDI terminal S8 activates, it will operate the function set to *H1-08 [Terminal S8 Function Selection]* and the function set to *H1-28* at the same time.

When the setting value is F, the function is disabled.

### ■ MEMOBUS/Modbus MFDI 1 to 3 Function Selection

You can set the function for the MFDI to MEMOBUS register bit 0 to 2 of [15C0(Hex.)]. Use *H1-40* to *H1-42 [Extend MFDI Function Selection]* to select the function.

**Note:**

- Refer to H1-xx “MFDI setting values” for the setting values of the MFDI.
- You cannot set 0 [3-Wire Sequence] or 20 to 2F [External fault] in H1-40 to H1-42.
- When you will not use H1-40 to H1-42, set them to F [Through Mode].
- You cannot use MFDI for digital input option D1-A3 at the same time as function selection for MEMOBUS/Modbus MFDI 1 to 3.

■ **H1-40: Mbus Reg 15C0h bit0 Input Func**

| No. (Hex.)   | Name                           | Description  | Default (Range) |
|--------------|--------------------------------|--|-----------------|
| H1-40 (0B54) | Mbus Reg 15C0h bit0 Input Func | <span>V/f</span> <span>CL-V/f</span> <span>OLV</span> <span>CLV</span> <span>AOLV</span> <span>OLV/PM</span> <span>AOLV/PM</span> <span>CLV/PM</span> <span>EZOLV</span><br>Selects MFDI function assigned to bit 0 of the MEMOBUS register 15C0 (Hex.). | F (1 - 19F)     |

■ **H1-41: Mbus Reg 15C0h bit1 Input Func**

| No. (Hex.)   | Name                           | Description  | Default (Range) |
|--------------|--------------------------------|--|-----------------|
| H1-41 (0B55) | Mbus Reg 15C0h bit1 Input Func | <span>V/f</span> <span>CL-V/f</span> <span>OLV</span> <span>CLV</span> <span>AOLV</span> <span>OLV/PM</span> <span>AOLV/PM</span> <span>CLV/PM</span> <span>EZOLV</span><br>Selects MFDI function assigned to bit 1 of the MEMOBUS register 15C0 (Hex.). | F (1 - 19F)     |

■ **H1-42: Mbus Reg 15C0h bit2 Input Func**

| No. (Hex.)   | Name                           | Description  | Default (Range) |
|--------------|--------------------------------|--|-----------------|
| H1-42 (0B56) | Mbus Reg 15C0h bit2 Input Func | <span>V/f</span> <span>CL-V/f</span> <span>OLV</span> <span>CLV</span> <span>AOLV</span> <span>OLV/PM</span> <span>AOLV/PM</span> <span>CLV/PM</span> <span>EZOLV</span><br>Selects MFDI function assigned to bit 2 of the MEMOBUS register 15C0 (Hex.). | F (1 - 19F)     |

◆ **Multi-Function Digital Input Setting Values**

Selects a function set with H1-01 to H1-08.

■ **0: 3-Wire Sequence**

| Setting Value | Function        | Description   |
|---------------|-----------------|---|
| 0             | 3-Wire Sequence | <span>V/f</span> <span>CL-V/f</span> <span>OLV</span> <span>CLV</span> <span>AOLV</span> <span>OLV/PM</span> <span>AOLV/PM</span> <span>CLV/PM</span> <span>EZOLV</span><br>Sets the direction of motor rotation for 3-wire sequence. |

If the 3-wire sequence is set to a terminal that is not MFDI terminals S1 and S2, these terminals will be the input terminals for Forward run/Reverse run command. The drive will automatically set terminal S1 to Run command (RUN) and terminal S2 to Stop command (STOP).

When terminal S1 (Run command) activates for 1 ms minimum, the drive rotates the motor. When terminal S2 (Stop command) deactivates, the drive stops. When terminal Sx that is set in 3-wire sequence deactivates, the drive operates in the forward direction, and when it activates, the drive operates in the reverse direction.

**WARNING! Sudden Movement Hazard.** Set the MFDI parameters before you close control circuit switches. Incorrect Run/Stop circuit sequence settings can cause serious injury or death from moving equipment.

**WARNING! Sudden Movement Hazard.** When you use a 3-Wire sequence, set A1-03 = 3330 [Initialize Parameters = 3-Wire Initialization] and make sure that b1-17 = 0 [Run Command at Power Up = Disregard Existing RUN Command] (default). If you do not correctly set the drive parameters for 3-Wire operation before you energize the drive, the motor can suddenly rotate in reverse when you energize the drive.

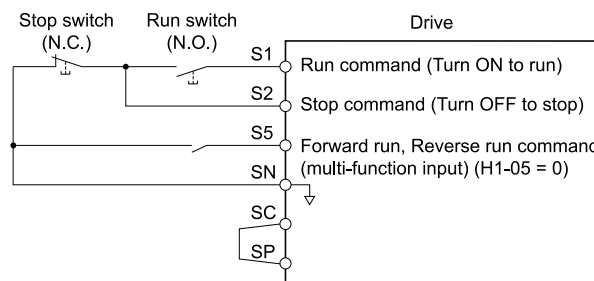


Figure 2.77 3-Wire Sequence Wiring Example

## 2.8 H: Terminal Functions

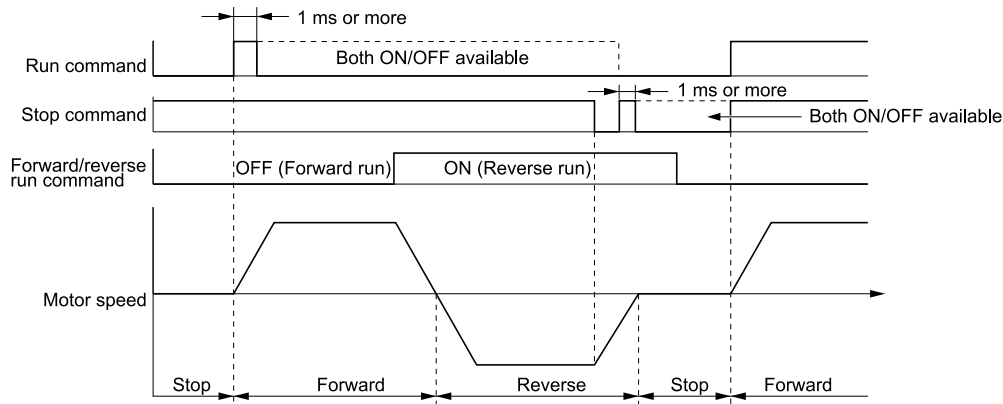


Figure 2.78 3-Wire Sequence Time Chart

**Note:**

- To input the Run command, activate the terminal for 1 ms minimum.
- The default setting for *b1-17 [Run Command at Power Up]* is 0 [Disregard existing RUN command]. The protective function activates and the **RUN** will flash quickly if the Run command was enabled when the drive was energized. If Run is permitted in the application, set *b1-17 = 1 [Accept Existing RUN Command]*.

### 1: LOCAL/REMOTE Selection

| Setting Value | Function               | Description   |
|---------------|------------------------|---|
| 1             | LOCAL/REMOTE Selection | <b>V/f</b> <b>CL-V/f</b> <b>OLV</b> <b>CLV</b> <b>AOLV</b> <b>OLV/PM</b> <b>AOLV/PM</b> <b>CLV/PM</b> <b>EZOLV</b><br>Sets drive control for the keypad (LOCAL) or an external source (REMOTE). |

**Note:**

- When the MFDI terminal sets the LOCAL/REMOTE selection, **LO/RE** on the keypad is disabled.
- When LOCAL Mode is selected, the green light for **LO/RE** comes on.
- When the Run command is ON, you cannot switch between LOCAL Mode and REMOTE Mode.

#### ON : LOCAL

The keypad is the Frequency reference source and Run command source.

#### OFF : REMOTE

The frequency reference and Run command settings are set in *b1-01, b1-02 [Frequency Reference Selection 1/2]* or *b1-15, b1-16 [Run Command Selection 1/2]*.

### 2: External Reference 1/2 Selection

| Setting Value | Function                         | Description   |
|---------------|----------------------------------|---|
| 2             | External Reference 1/2 Selection | <b>V/f</b> <b>CL-V/f</b> <b>OLV</b> <b>CLV</b> <b>AOLV</b> <b>OLV/PM</b> <b>AOLV/PM</b> <b>CLV/PM</b> <b>EZOLV</b><br>Sets the drive to use Run command source 1/2 or Reference command source 1/2 when in REMOTE Mode. |

**Note:**

When the drive is receiving a Run command, you cannot switch between reference sources.

**ON : *b1-15 = [Frequency Reference Selection 2], b1-16 [Run Command Selection 2]***

**OFF : *b1-01 = [Frequency Reference Selection 1], b1-02 [Run Command Selection 1]***

### 3: Multi-Step Speed Reference 1

| Setting Value | Function                     | Description  |
|---------------|------------------------------|--|
| 3             | Multi-Step Speed Reference 1 | <b>V/f</b> <b>CL-V/f</b> <b>OLV</b> <b>CLV</b> <b>AOLV</b> <b>OLV/PM</b> <b>AOLV/PM</b> <b>CLV/PM</b> <b>EZOLV</b><br>Uses speed references <i>d1-01 to d1-16</i> to set a multi-step speed reference. |



**Note:**

Refer to “Setting Procedures for Multi-step Speed Operation” in “d: Reference Settings” for more information.

■ **4: Multi-Step Speed Reference 2**

| Setting Value | Function                                | Description   |
|---------------|---|---|
| 4             | Multi-Step Speed Reference <sup>2</sup> | <b>V/f</b> <b>CL-V/f</b> <b>OLV</b> <b>CLV</b> <b>AOLV</b> <b>OLV/PM</b> <b>AOLV/PM</b> <b>CLV/PM</b> <b>EZOLV</b><br>Uses speed references <i>d1-01</i> to <i>d1-16</i> to set a multi-step speed reference. |

**Note:**

Refer to “Setting Procedures for Multi-step Speed Operation” in “d: Reference Settings” for more information.

■ **5: Multi-Step Speed Reference 3**

| Setting Value | Function                                | Description   |
|---------------|---|---|
| 5             | Multi-Step Speed Reference <sup>3</sup> | <b>V/f</b> <b>CL-V/f</b> <b>OLV</b> <b>CLV</b> <b>AOLV</b> <b>OLV/PM</b> <b>AOLV/PM</b> <b>CLV/PM</b> <b>EZOLV</b><br>Uses speed references <i>d1-01</i> to <i>d1-16</i> to set a multi-step speed reference. |

**Note:**

Refer to “Setting Procedures for Multi-step Speed Operation” in “d: Reference Settings” for more information.

■ **6: Jog Reference Selection**

| Setting Value | Function                | Description  |
|---------------|-------------------------|--|
| 6             | Jog Reference Selection | <b>V/f</b> <b>CL-V/f</b> <b>OLV</b> <b>CLV</b> <b>AOLV</b> <b>OLV/PM</b> <b>AOLV/PM</b> <b>CLV/PM</b> <b>EZOLV</b><br>Sets the drive to use the JOG Frequency Reference (JOG command) set in <i>d1-17</i> . The JOG Frequency Reference (JOG command) overrides Frequency References 1 to 16 ( <i>d1-01</i> to <i>d1-16</i> ). |

■ **7: Accel/Decel Time Selection 1**

| Setting Value | Function                                | Description   |
|---------------|---|---|
| 7             | Accel/Decel Time Selection <sup>1</sup> | <b>V/f</b> <b>CL-V/f</b> <b>OLV</b> <b>CLV</b> <b>AOLV</b> <b>OLV/PM</b> <b>AOLV/PM</b> <b>CLV/PM</b> <b>EZOLV</b><br>Sets the drive to use <i>Acceleration/Deceleration Time 1</i> [ <i>C1-01</i> , <i>C1-02</i> ] or <i>Acceleration/Deceleration Time 2</i> [ <i>C1-03</i> , <i>C1-04</i> ]. |

**Note:**

Refer to “C1: Accel & Decel Time” for more information.

■ **8: Baseblock Command (N.O.)**

| Setting Value | Function                 | Description   |
|---------------|--------------------------|---|
| 8             | Baseblock Command (N.O.) | <b>V/f</b> <b>CL-V/f</b> <b>OLV</b> <b>CLV</b> <b>AOLV</b> <b>OLV/PM</b> <b>AOLV/PM</b> <b>CLV/PM</b> <b>EZOLV</b><br>Sets the command that stops drive output and coasts the motor to stop when the input is ON. |

The keypad flashes *bb* [Baseblock]. If you cancel the baseblock command when the Run command is active, the drive will restart the motor and use the speed search function.

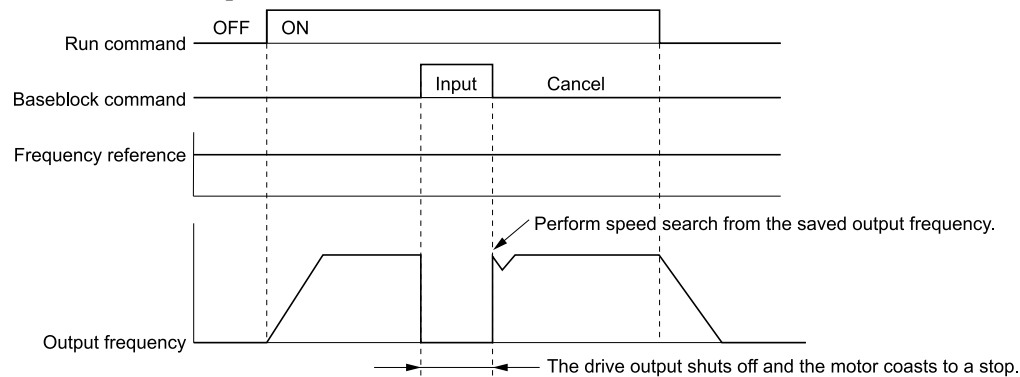


Figure 2.79 Baseblock Command Time Chart

**ON : Baseblock (drive output stop)**  
**OFF : Normal operation**

■ **9: Baseblock Command (N.C.)**

| Setting Value | Function                 | Description  |
|---------------|--------------------------|--|
| 9             | Baseblock Command (N.C.) | <div style="display: flex; justify-content: space-between; align-items: center;"> <span>V/f</span> <span>CL-V/f</span> <span>OLV</span> <span>CLV</span> <span>AOLV</span> <span>OLV/PM</span> <span>AOLV/PM</span> <span>CLV/PM</span> <span>EZOLV</span> </div> <p>Sets the command that stops drive output and coasts the motor to stop when the input terminal is OFF.</p> |

The keypad flashes *bb* [Baseblock]. If you cancel the baseblock command when the Run command is active, the drive will restart the motor and use the speed search function.

**ON : Normal operation**

**OFF : Baseblock (drive output stop)**

■ **A: Accel/Decel Ramp Hold**

| Setting Value | Function              | Description   |
|---------------|-----------------------|---|
| A             | Accel/Decel Ramp Hold | <div style="display: flex; justify-content: space-between; align-items: center;"> <span>V/f</span> <span>CL-V/f</span> <span>OLV</span> <span>CLV</span> <span>AOLV</span> <span>OLV/PM</span> <span>AOLV/PM</span> <span>CLV/PM</span> <span>EZOLV</span> </div> <p>Momentarily pauses motor acceleration and deceleration when the terminal is turned ON, retains the output frequency that was stored in the drive at the time of the pause, and restarts motor operation.</p> |

If the terminal is deactivated, the drive restarts acceleration and deceleration.

When the acceleration/deceleration ramp hold terminal is activated and  $d4-01 = 1$  [Freq Reference Retention Select = Enabled], the drive will store the output frequency in memory. While the acceleration/deceleration ramp hold command is activated, the drive will always restart the motor at this output frequency.

**Note:**

Refer to “d4-01: Freq Reference Retention Select” for more information.

■ **B: Overheat Alarm (oH2)**

| Setting Value | Function             | Description   |
|---------------|----------------------|---|
| B             | Overheat Alarm (oH2) | <div style="display: flex; justify-content: space-between; align-items: center;"> <span>V/f</span> <span>CL-V/f</span> <span>OLV</span> <span>CLV</span> <span>AOLV</span> <span>OLV/PM</span> <span>AOLV/PM</span> <span>CLV/PM</span> <span>EZOLV</span> </div> <p>Sets the drive to display an oH2 [Drive Overheat Warning] alarm when the input terminal is ON. The alarm does not have an effect on drive operation.</p> |

■ **C: Analog Terminal Enable Selection**

| Setting Value | Function                         | Description  |
|---------------|----------------------------------|--|
| C             | Analog Terminal Enable Selection | <div style="display: flex; justify-content: space-between; align-items: center;"> <span>V/f</span> <span>CL-V/f</span> <span>OLV</span> <span>CLV</span> <span>AOLV</span> <span>OLV/PM</span> <span>AOLV/PM</span> <span>CLV/PM</span> <span>EZOLV</span> </div> <p>Sets the command that enables or disables the terminals selected in H3-14 [Analog Input Terminal Enable Sel].</p> |

**ON : Terminal selected with H3-14 is enabled**

**OFF : Terminal selected with H3-14 is disabled**

■ **D: Ignore Speed Fdbk (V/f w/o Enc)**

| Setting Value | Function                        | Description  |
|---------------|---------------------------------|--|
| D             | Ignore Speed Fdbk (V/f w/o Enc) | <div style="display: flex; justify-content: space-between; align-items: center;"> <span>V/f</span> <span>CL-V/f</span> <span>OLV</span> <span>CLV</span> <span>AOLV</span> <span>OLV/PM</span> <span>AOLV/PM</span> <span>CLV/PM</span> <span>EZOLV</span> </div> <p>Sets the command to disable speed feedback control and run the drive in V/f control or use speed feedback from the encoder.</p> |

**ON : Speed feedback control disable (V/f Control)**

**OFF : Speed feedback control enable (Closed Loop V/f Control)**

■ **E: ASR Integral Reset**

| Setting Value | Function           | Description   |
|---------------|--------------------|---|
| E             | ASR Integral Reset | <div style="display: flex; justify-content: space-between; align-items: center;"> <span>V/f</span> <span>CL-V/f</span> <span>OLV</span> <span>CLV</span> <span>AOLV</span> <span>OLV/PM</span> <span>AOLV/PM</span> <span>CLV/PM</span> <span>EZOLV</span> </div> <p>Sets the command to reset the integral value and use PI control or P control for the speed control loop.</p> |

**ON : P control**

**OFF : PI control**

## ■ F: Not Used

| Setting Value | Function | Description  |
|---------------|----------|--|
| F             | Not Used | <b>V/f</b> <b>CL-V/f</b> <b>OLV</b> <b>CLV</b> <b>AOLV</b> <b>OLV/PM</b> <b>AOLV/PM</b> <b>CLV/PM</b> <b>EZOLV</b><br>Use this setting for unused terminals or to use terminals in through mode. |

Through Mode uses the signal input to the terminal as a digital input for the upper sequence through a communication option or MEMOBUS/Modbus communications. This input signal does not have an effect on drive operation.

## ■ 10: Up Command

| Setting Value | Function   | Description  |
|---------------|------------|--|
| 10            | Up Command | <b>V/f</b> <b>CL-V/f</b> <b>OLV</b> <b>CLV</b> <b>AOLV</b> <b>OLV/PM</b> <b>AOLV/PM</b> <b>CLV/PM</b> <b>EZOLV</b><br>Sets the command to use a push button switch to increase the drive frequency reference. You must also set <i>Setting 11 [Down Command]</i> . |

**ON** : Increases the frequency reference.

**OFF** : Holds the current frequency reference.

### Note:

- If you set only the Up command or only the Down command, the drive will detect *oPE03 [Multi-Function Input Setting Err]*.
- If you set two or more of these functions at the same time, the drive will detect *oPE03*:
  - Up/Down command
  - Accel/Decel Ramp Hold
  - Reference Sample Hold
  - Offset Frequency 1, 2, 3 addition
  - Up/Down 2 Command
- The Up/Down command does not work in the following cases.
  - b1-01 = 2, 3 [Frequency Reference Selection 1 = Memobus/Modbus Communications, Option PCB]*
  - b1-02 ≠ 1 [Run Command Selection 1 ≠ Control Circuit Terminal]*
  - Drive is in LOCAL mode
  - Set to *b1-15 [Frequency Reference Selection 2]* by use of *H1-xx = 2 [MFDI Function Select = External Reference 1/2 Selection]*

The frequency reference is increased when you enter the UP command or decreased when you enter the Down command.

The Up and Down commands have priority over all other frequency references. When you enable the Up/Down command, the drive will ignore these frequency references:

- Frequency reference from Keypad [*b1-01 = 0*]
- Frequency reference from Analog Input [*b1-01 = 1*]
- Frequency reference from Pulse Train Input [*b1-01 = 4*]

Table 2.56 shows the Up and Down commands with their operation.

**Table 2.56 Up Command and Down Command**

| Command status  |                   | Drive operation                        |
|-----------------|-------------------|--|
| Up command (10) | Down command (11) |  |
| OFF             | OFF               | Keeps the current frequency reference. |
| ON              | OFF               | Increases the frequency reference.     |
| OFF             | ON                | Decreases the frequency reference.     |
| ON              | ON                | Keeps the current frequency reference. |

### Combine Frequency Reference Hold Functions and Up/Down Commands

- When you clear the Run command or when *d4-01 = 0 [Freq Reference Hold Selection = Disabled]*, and you restart the drive, the Up/Down command resets to 0.
- When *d4-01 = 1 [Enabled]*, the drive saves the frequency reference set during the Up/Down command. When you cycle the Run command or restart the drive, the drive saves the frequency reference value and restarts the motor at this frequency value. After you clear the Run command, activate the terminal set for the Up command or Down command to set the saved reference value to 0.

## 2.8 H: Terminal Functions

**Note:**

Refer to “d4-01 [Freq Reference Hold Selection]” for details.

### Combine Upper/Lower Limits of the Frequency Reference and the Up/Down Commands

Set the upper limit value of the frequency reference to *d2-01* [Frequency Reference Upper Limit].

Use an analog input or *d2-02* [Frequency Reference Lower Limit] to set the lower limit value of the frequency reference. The configurable values change when the setting for *d4-10* [Up/Down Freq Lower Limit Select] changes. When you input a Run command, these are the lower limits of the frequency reference:

- When the lower limit of the frequency reference is set only for *d2-02*, the drive accelerates the motor to the lower limit value of the frequency reference at the same time that you input the Run command.
- When the lower limit of the frequency reference is set only for analog input, the drive accelerates the motor to the lower limit value of the frequency reference when the Run command, and Up command or Down command for the drive is enabled. When only the Run command is enabled, the motor does not start.
- When these conditions occur, the drive accelerates the motor to the *d2-02* setting value when the Run command is input. When the motor accelerates to the setting value of *d2-02*, if the Up/Down command is enabled, the motor accelerates to the lower limit value of the analog input.
  - The lower limit value of the frequency reference is set for the analog input and *d2-02*
  - The lower limit value of the analog input is higher than the setting value of *d2-02*

**Note:**

Refer to “d4-10: Up/Down Freq Lower Limit Select” for details.

Figure 2.80 shows an example of how Up/Down command operates. In this example, the lower limit value of the frequency reference is set in *d2-02*. Figure 2.80 shows the time chart when Freq Reference Retention Select [*d4-01*] is enabled and disabled.

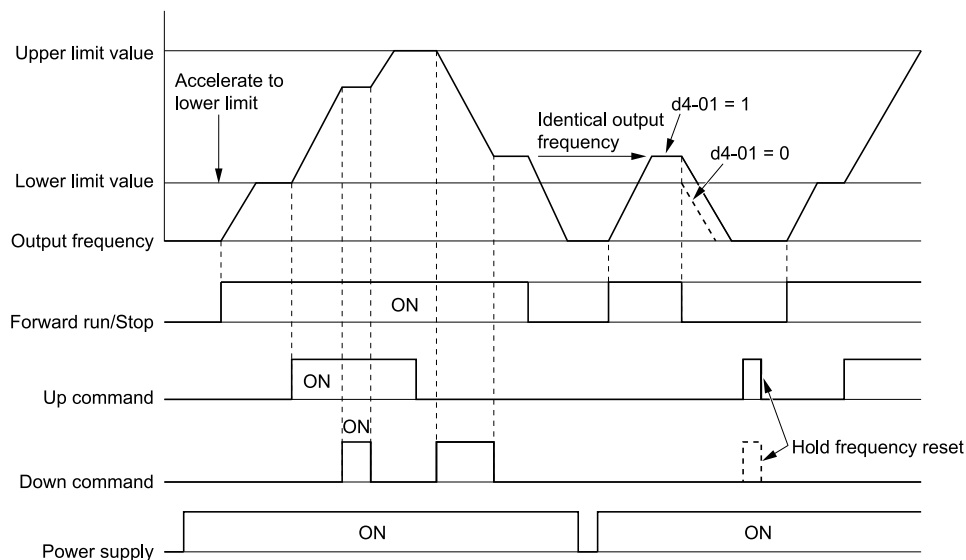


Figure 2.80 Up/Down Command Time Chart

### 11: Down Command

| Setting Value | Function     | Description  |
|---------------|--------------|--|
| 11            | Down Command | <div style="display: flex; gap: 5px;"> <span>V/f</span> <span>CL-V/f</span> <span>OLV</span> <span>CLV</span> <span>AOLV</span> <span>OLV/PM</span> <span>AOLV/PM</span> <span>CLV/PM</span> <span>EZOLV</span> </div> <p>Sets the command to use a push button switch to decrease the drive frequency reference. You must also set Setting 10 [Up Command].</p> |

**ON** : Decreases the frequency reference.

**OFF** : Holds the current frequency reference.

**Note:**

- If you set only the Up command or only the Down command, the drive will detect *oPE03* [Multi-Function Input Setting Err].
- If you set two or more of these functions at the same time, the drive will detect *oPE03*:
  - Up/Down command
  - Accel/Decel Ramp Hold
  - Reference Sample Hold
  - Offset Frequency 1, 2, 3 addition
  - Up/Down 2 Command
- The Up/Down command does not work in the following cases.
  - b1-01* = 2, 3 [Frequency Reference Selection 1 = Memobus/Modbus Communications, Option PCB]
  - b1-02* ≠ 1 [Run Command Selection 1 ≠ Control Circuit Terminal]
  - Drive is in LOCAL mode
  - Set to *b1-15* [Frequency Reference Selection 2] by use of *H1-xx* = 2 [MFDI Function Select = External Reference 1/2 Selection]

The frequency reference is increased when you enter the UP command or decreased when you enter the Down command.

The Up and Down commands have priority over all other frequency references. When you enable the Up/Down command, the drive will ignore these frequency references:

- Frequency reference from Keypad [*b1-01* = 0]
- Frequency reference from Analog Input [*b1-01* = 1]
- Frequency reference from Pulse Train Input [*b1-01* = 4]

■ **12: Forward Jog**

| Setting Value | Function    | Description   |
|---------------|-------------|---|
| 12            | Forward Jog | <div style="display: flex; justify-content: space-between; font-size: small;"> <span>V/f</span> <span>CL-V/f</span> <span>OLV</span> <span>CLV</span> <span>AOLV</span> <span>OLV/PM</span> <span>AOLV/PM</span> <span>CLV/PM</span> <span>EZOLV</span> </div> Sets the command to operate the motor in the forward direction at the Jog Frequency set in <i>d1-17</i> [Jog Reference]. |

**Note:**

- It is not necessary to input the Run command.
- The Forward JOG command has priority over all other frequency references.
- When the Forward JOG and Reverse JOG commands are activated at the same time for 500 ms or longer, the drive will ramp to stop.

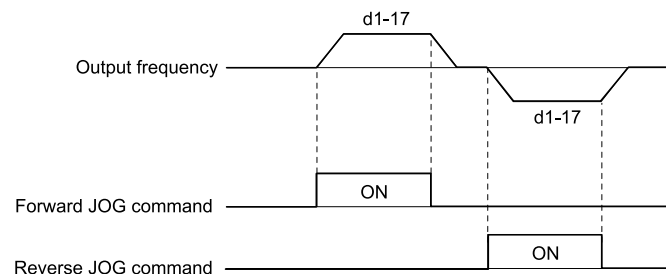


Figure 2.81 JOG Operation Pattern

■ **13: Reverse Jog**

| Setting Value | Function    | Description   |
|---------------|-------------|---|
| 13            | Reverse Jog | <div style="display: flex; justify-content: space-between; font-size: small;"> <span>V/f</span> <span>CL-V/f</span> <span>OLV</span> <span>CLV</span> <span>AOLV</span> <span>OLV/PM</span> <span>AOLV/PM</span> <span>CLV/PM</span> <span>EZOLV</span> </div> Sets the command to operate the motor in the reverse direction at the Jog Frequency set in <i>d1-17</i> [Jog Reference]. |


**Note:**

- It is not necessary to input the Run command.
- The Reverse JOG command has priority over all other frequency references.
- When the Forward JOG and Reverse JOG commands are activated at the same time for 500 ms or longer, the drive will ramp to stop.

■ 14: Fault Reset

| Setting Value | Function              | Description   |
|---------------|-----------------------|---|
| 14            | Fault Reset Procedure | <b>V/f</b> <b>CL-V/f</b> <b>OLV</b> <b>CLV</b> <b>AOLV</b> <b>OLV/PM</b> <b>AOLV/PM</b> <b>CLV/PM</b> <b>EZOLV</b><br>Sets the command to reset the current fault when the Run command is inactive. |

If the drive detects a fault, the drive will activate the fault relay output, turn off the output, and the motor will coast to stop.

If the drive detects a fault for which you can set the stopping method, apply the appropriate Stopping Method. Then push  (RESET) on the keypad to turn the Run command OFF, or activate the fault reset terminal to reset the fault.

**Note:**

The drive ignores the fault reset command when the Run command is active. Remove the Run command before trying to reset a fault.

■ 15: Fast Stop (N.O.)

| Setting Value | Function         | Description   |
|---------------|------------------|---|
| 15            | Fast Stop (N.O.) | <b>V/f</b> <b>CL-V/f</b> <b>OLV</b> <b>CLV</b> <b>AOLV</b> <b>OLV/PM</b> <b>AOLV/PM</b> <b>CLV/PM</b> <b>EZOLV</b><br>Sets the command to ramp to stop in the deceleration time set in C1-09 [Fast Stop Time] when the input terminal is ON while the drive is operating. |

If you cancel the fast stop input, the drive will not restart the motor until you meet these conditions:

- Fully stop the motor
- Cancel the Run command
- Cancel the fast stop command

**Note:**

- To use the N.C. switch to input the fast stop command, set 17 (Fast Stop (N.C.)).
- For details, refer to C1-09 [Fast Stop Time].
- Set C1-09 [Fast Stop Time] to a correct deceleration time. If the deceleration time is too short, an overvoltage fault may occur, possibly resulting in failure to stop the motor from coasting.

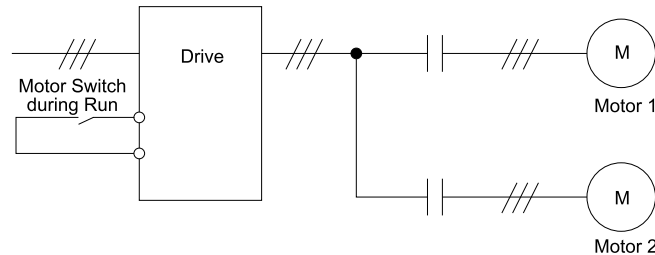
■ 16: Motor 2 Selection

| Setting Value | Function          | Description   |
|---------------|-------------------|---|
| 16            | Motor 2 Selection | <b>V/f</b> <b>CL-V/f</b> <b>OLV</b> <b>CLV</b> <b>AOLV</b> <b>OLV/PM</b> <b>AOLV/PM</b> <b>CLV/PM</b> <b>EZOLV</b><br>Sets the command for the drive to operate motor 1 or motor 2. Stop the motors before switching. |

You can use an external input to switch operation between two induction motors. The drive will save the control methods, V/f patterns, and motor parameters for the two motors.

**ON : Selects motor 2**

**OFF : Selects motor 1**



When you select motor 2, the drive will switch to motor 2 parameters.

**Table 2.57 Parameters that Switch between Motor 1 and Motor 2**

| Parameter                   | Motor 2 Selection |                |
|-----------------------------|-------------------|----------------|
|                             | OFF (Motor 1)     | ON (Motor 2)   |
| C1-xx [Accel & Decel Time]  | C1-01 to C1-04    | C1-05 to C1-08 |
| C3-xx [Slip Compensation]   | C3-01 to C3-04    | C3-21 to C3-24 |
| C4-xx [Torque Compensation] | C4-01             | C4-07          |

| Parameter  | Motor 2 Selection                   |   |
|--|-------------------------------------|---|
|  | OFF (Motor 1)                       | ON (Motor 2)  |
| C5-xx [Automatic Speed Regulator (ASR)]                        | C5-01 to C5-08, C5-12, C5-17, C5-18 | C5-21 to C5-28, C5-32, C5-37, C5-38                   |
| E1-xx, E3-xx [V/f Patterns]<br>E2-xx, E-4xx [Motor Parameters] | E1-xx, E2-xx                        | E3-xx, E4-xx  |
| F1-xx [Number of PG pulses per Revolution]                     | F1-01 to F1-21                      | F1-02 to F1-04, F1-08 to F1-11, F1-14, F1-31 to F1-37 |

**Note:**

- When you use 2 motors, the drive applies the protective function set in *L1-01 [Motor Overload Protection Select]* to motor 1 and motor 2.
- You cannot switch between motors 1 and 2 during run. If you try to switch motors when they are running, it will cause a *rUn* error.
- After you switch between encoder motors, you must wait 500 ms minimum to input a Run command. You must wait 200 ms minimum for other control methods.
- If you set *H1-xx=16 [Motor 2 Selection]* and set control methods different in maximum output frequency to motors 1 and 2, respectively, either of the maximum output frequencies, whichever is lower, will be applied to the both motors. The upper limit of *d1-xx [Frequency Reference]* will be changed. For example, the upper limit of *d1-xx* will be 400 if you configure the settings as follows.
  - A1-02 = 2 [Control Method Selection = OLV]
  - E1-04 = 590 [Maximum Output Frequency = 590 Hz]
  - E3-01 = 3 [Motor 2 Control Mode Selection = CLV]
  - E3-04 = 400 [Motor 2 Maximum Output Frequency = 400 Hz]

■ **17: Fast Stop (N.C.)**

| Setting Value | Function         | Description  |
|---------------|------------------|--|
| 17            | Fast Stop (N.C.) | <div style="display: flex; justify-content: space-between; font-size: small;"> <span>V/f</span> <span>CL-V/f</span> <span>OLV</span> <span>CLV</span> <span>AOLV</span> <span>OLV/PM</span> <span>AOLV/PM</span> <span>CLV/PM</span> <span>EZOLV</span> </div> <p>Sets the command to ramp to stop in the deceleration time set in <i>C1-09 [Fast Stop Time]</i> when the input terminal is ON while the drive is operating.</p> |

If you cancel the fast stop input, the drive will not restart the motor until you meet these conditions:

- Fully stop the motor
- Cancel the Run command
- Cancel the fast stop command

**Note:**

- To use the N.O. switch to input the fast stop command, set 15 (Fast Stop (N.O.)).
- For details, refer to *C1-09 [Fast Stop Time]*.
- Set *C1-09 [Fast Stop Time]* to a correct deceleration time. If the deceleration time is too short, an overvoltage fault may occur, possibly resulting in failure to stop the motor from coasting.

Figure 2.82 shows an example of how fast stop operates.

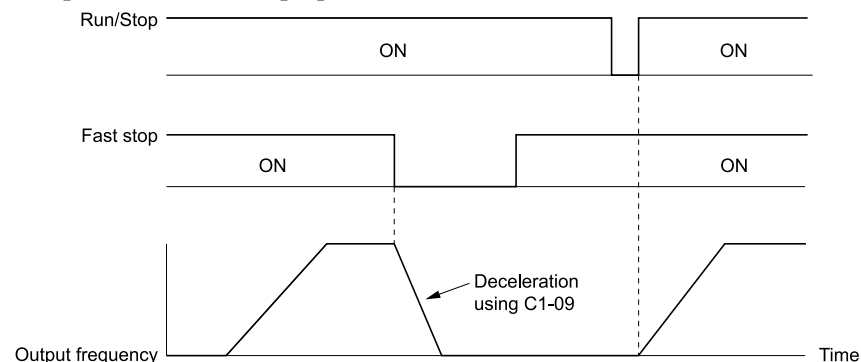


Figure 2.82 Fast Stop Time Chart

■ **18: Timer Function**

| Setting Value | Function       | Description   |
|---------------|----------------|---|
| 18            | Timer Function | <div style="display: flex; justify-content: space-between; font-size: small;"> <span>V/f</span> <span>CL-V/f</span> <span>OLV</span> <span>CLV</span> <span>AOLV</span> <span>OLV/PM</span> <span>AOLV/PM</span> <span>CLV/PM</span> <span>EZOLV</span> </div> <p>Sets the command to start the timer function. Use this setting with <i>Timer Output [H2-xx = 12]</i>.</p> |

Parameter Details

## 2.8 H: Terminal Functions

**Note:**

Refer to “b4: Timer Function” for more information.

### 19: PID Disable

| Setting Value | Function    | Description   |
|---------------|-------------|---|
| 19            | PID Disable | <div style="display: flex; justify-content: space-between; gap: 5px;"> <span>V/f</span> <span>CL-V/f</span> <span>OLV</span> <span>CLV</span> <span>AOLV</span> <span>OLV/PM</span> <span>AOLV/PM</span> <span>CLV/PM</span> <span>EZOLV</span> </div> <p>Sets the command to disable PID control when <math>b5-01 = 1</math> to <math>8</math> [PID Mode Setting = Enabled].</p> |

**ON :** PID control disabled

**OFF :** PID control enabled

### 1A: Accel/Decel Time Selection 2

| Setting Value | Function                        | Description   |
|---------------|---------------------------------|---|
| 1A            | Accel/Decel Time Selection<br>2 | <div style="display: flex; justify-content: space-between; gap: 5px;"> <span>V/f</span> <span>CL-V/f</span> <span>OLV</span> <span>CLV</span> <span>AOLV</span> <span>OLV/PM</span> <span>AOLV/PM</span> <span>CLV/PM</span> <span>EZOLV</span> </div> <p>Set this function and <math>H1-xx = 7</math> [Accel/Decel Time Selection 1] together. Sets the drive to use Acceleration/Deceleration Time 3 [C1-05, C1-06] or Acceleration/Deceleration Time 4 [C1-07, C1-08].</p> |

**Note:**

Refer to “C1: Accel & Decel Time” for more information.

### 1B: Programming Lockout

| Setting Value | Function            | Description   |
|---------------|---------------------|---|
| 1B            | Programming Lockout | <div style="display: flex; justify-content: space-between; gap: 5px;"> <span>V/f</span> <span>CL-V/f</span> <span>OLV</span> <span>CLV</span> <span>AOLV</span> <span>OLV/PM</span> <span>AOLV/PM</span> <span>CLV/PM</span> <span>EZOLV</span> </div> <p>Sets the command to prevent parameter changes when the terminal is OFF.</p> |

You can continue to view parameter setting values when the terminal is *OFF* [Parameters Cannot be Edited].

**ON :** Program Lockout

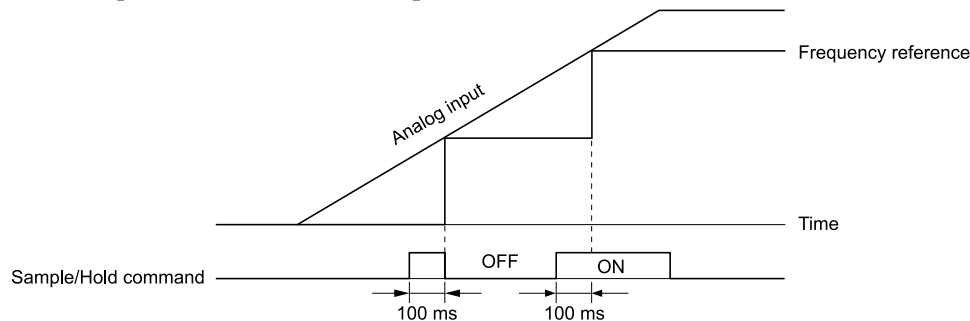
**OFF :** Parameter Write Prohibit

### 1E: Reference Sample Hold

| Setting Value | Function              | Description   |
|---------------|-----------------------|---|
| 1E            | Reference Sample Hold | <div style="display: flex; justify-content: space-between; gap: 5px;"> <span>V/f</span> <span>CL-V/f</span> <span>OLV</span> <span>CLV</span> <span>AOLV</span> <span>OLV/PM</span> <span>AOLV/PM</span> <span>CLV/PM</span> <span>EZOLV</span> </div> <p>Sets the command to sample the frequency reference at terminals A1, A2, or A3 and hold the frequency reference at that frequency.</p> |

When the terminal is active for 100 ms, this function reads a sample of the analog frequency reference and holds that sample. When you input the sample/hold command again, the function again reads a sample of the analog frequency reference and holds that sample. When you turn off the power, the drive erases the saved analog frequency and resets the frequency reference to 0.

Figure 2.83 shows an example of how the function operates.



**Figure 2.83 Reference Sample Hold**

You cannot set the Reference Sample Hold function at the same time as these functions:

- $H1-xx = A$  [Accel/Decel Ramp Hold]
- $H1-xx = 10, 11$  [Up Command, Down Command]
- $H1-xx = 44$  to  $46$  [Offset Frequency 1 to 3]



- *HI-xx = 75, 76 [Up 2 Command, Down 2 Command]*

If you set them at the same time, the drive will detect *oPE03 [Multi-Function Input Setting Err]*.

■ **20 to 2F: External Fault**

| Setting Value | Function       | Description   |
|---------------|----------------|---|
| 20 to 2F      | External fault | <div style="display: flex; justify-content: space-between; align-items: center;"> <span>V/f</span> <span>CL-V/f</span> <span>OLV</span> <span>CLV</span> <span>AOLV</span> <span>OLV/PM</span> <span>AOLV/PM</span> <span>CLV/PM</span> <span>EZOLV</span> </div> <p>Sets a command to stop the drive when a failure or fault occurs on an external device.</p> |

If an external fault is input to the drive, the keypad will show *EFx [External Fault (Terminal Sx)]*, where x is the number of the terminal (terminal Sx) to which the external fault signal is assigned. For example, when an external fault signal is input to terminal S3, the keypad will show EF3.

Use these conditions to select the value to set in *HI-xx*:

- Signal input method from peripheral devices
- External fault detection method
- Motor stopping method (operation after external fault detection)

Table 2.58 shows the relation between the conditions and the value set to *HI-xx*.

**Table 2.58 Stopping Methods for External Fault**

| Setting | Signal Input Method from Peripheral Devices *1 |      | External Fault Detection Method *2 |                          | Stopping Method      |                       |                   |                                   |
|---------|--|------|------------------------------------|--------------------------|----------------------|-----------------------|-------------------|-----------------------------------|
|         | N.O.   | N.C. | Always Detected                    | Detected during RUN Only | Ramp to Stop (Fault) | Coast to Stop (Fault) | Fast Stop (Fault) | Continuous Operation (Alarm Only) |
| 20      | x  | -    | x                                  | -                        | x                    | -                     | -                 | -                                 |
| 21      | -  | x    | x                                  | -                        | x                    | -                     | -                 | -                                 |
| 22      | x  | -    | -                                  | x                        | x                    | -                     | -                 | -                                 |
| 23      | -  | x    | -                                  | x                        | x                    | -                     | -                 | -                                 |
| 24      | x  | -    | x                                  | -                        | -                    | x                     | -                 | -                                 |
| 25      | -  | x    | x                                  | -                        | -                    | x                     | -                 | -                                 |
| 26      | x  | -    | -                                  | x                        | -                    | x                     | -                 | -                                 |
| 27      | -  | x    | -                                  | x                        | -                    | x                     | -                 | -                                 |
| 28      | x  | -    | x                                  | -                        | -                    | -                     | x                 | -                                 |
| 29      | -  | x    | x                                  | -                        | -                    | -                     | x                 | -                                 |
| 2A      | x  | -    | -                                  | x                        | -                    | -                     | x                 | -                                 |
| 2B      | -  | x    | -                                  | x                        | -                    | -                     | x                 | -                                 |
| 2C      | x  | -    | x                                  | -                        | -                    | -                     | -                 | x                                 |
| 2D      | -  | x    | x                                  | -                        | -                    | -                     | -                 | x                                 |
| 2E      | x  | -    | -                                  | x                        | -                    | -                     | -                 | x                                 |
| 2F      | -  | x    | -                                  | x                        | -                    | -                     | -                 | x                                 |

\*1 Set the terminal to N.O. (detects external fault when switched ON) or N.C. (detects external fault when switched OFF).

\*2 Set the drive to always detect each fault or to detect only during run.

■ **30: PID Integrator Reset**

| Setting Value | Function             | Description  |
|---------------|----------------------|--|
| 30            | PID Integrator Reset | <div style="display: flex; justify-content: space-between; align-items: center;"> <span>V/f</span> <span>CL-V/f</span> <span>OLV</span> <span>CLV</span> <span>AOLV</span> <span>OLV/PM</span> <span>AOLV/PM</span> <span>CLV/PM</span> <span>EZOLV</span> </div> <p>Sets the command to reset and hold the PID control integral to 0 when the terminal is ON.</p> |

**Note:**

Refer to “PID control block diagram” for more information.

## 2.8 H: Terminal Functions

### ■ 31: PID Integrator Hold

| Setting Value | Function            | Description   |
|---------------|---------------------|---|
| 31            | PID Integrator Hold | <b>V/f</b> <b>CL-V/f</b> <b>OLV</b> <b>CLV</b> <b>AOLV</b> <b>OLV/PM</b> <b>AOLV/PM</b> <b>CLV/PM</b> <b>EZOLV</b><br>Sets the command to hold the integral value of the PID control while the terminal is activated. |

When you turn off the input terminal, PID control restarts the integral.

**Note:**

Refer to "PID control block diagram" for more information.

### ■ 32: Multi-Step Speed Reference 4

| Setting Value | Function                        | Description   |
|---------------|---------------------------------|---|
| 32            | Multi-Step Speed Reference<br>4 | <b>V/f</b> <b>CL-V/f</b> <b>OLV</b> <b>CLV</b> <b>AOLV</b> <b>OLV/PM</b> <b>AOLV/PM</b> <b>CLV/PM</b> <b>EZOLV</b><br>Uses speed references <i>d1-01</i> to <i>d1-16</i> to set a multi-step speed reference. |

**Note:**

Refer to "Setting Procedures for Multi-step Speed Operation" in "d: Reference Settings" for more information.

### ■ 34: PID Soft Starter Disable

| Setting Value | Function                 | Description   |
|---------------|--------------------------|---|
| 34            | PID Soft Starter Disable | <b>V/f</b> <b>CL-V/f</b> <b>OLV</b> <b>CLV</b> <b>AOLV</b> <b>OLV/PM</b> <b>AOLV/PM</b> <b>CLV/PM</b> <b>EZOLV</b><br>Sets the PID soft starter function. |

**ON : Disabled**

Disables *b5-17* [PID Accel/Decel Time].

**OFF : Enabled**

Enables *b5-17* [PID Accel/Decel Time].

**Note:**

Refer to "PID control block diagram" for more information.

### ■ 35: PID Input (Error) Invert

| Setting Value | Function                 | Description  |
|---------------|--------------------------|--|
| 35            | PID Input (Error) Invert | <b>V/f</b> <b>CL-V/f</b> <b>OLV</b> <b>CLV</b> <b>AOLV</b> <b>OLV/PM</b> <b>AOLV/PM</b> <b>CLV/PM</b> <b>EZOLV</b><br>Sets the command to turn the terminal ON and OFF to switch the PID input level (polarity). |

**Note:**

Refer to "PID control block diagram" for more information.

### ■ 3E: PID Setpoint Selection 1

| Setting Value | Function                 | Description  |
|---------------|--------------------------|--|
| 3E            | PID Setpoint Selection 1 | <b>V/f</b> <b>CL-V/f</b> <b>OLV</b> <b>CLV</b> <b>AOLV</b> <b>OLV/PM</b> <b>AOLV/PM</b> <b>CLV/PM</b> <b>EZOLV</b><br>Set this function and <i>H1-xx</i> = 3F [PID Setpoint Selection 2] together. Sets the function to switch the PID setpoint to <i>b5-58</i> to <i>b5-60</i> [PID Setpoint 2 to 4]. |

Refer to "b5-58 to b5-60: PID Setpoint 2 to 4" for more information.

### ■ 3F: PID Setpoint Selection 2

| Setting Value | Function                 | Description  |
|---------------|--------------------------|--|
| 3F            | PID Setpoint Selection 2 | <b>V/f</b> <b>CL-V/f</b> <b>OLV</b> <b>CLV</b> <b>AOLV</b> <b>OLV/PM</b> <b>AOLV/PM</b> <b>CLV/PM</b> <b>EZOLV</b><br>Set this function and <i>H1-xx</i> = 3E [PID Setpoint Selection 1] together. Sets the function to switch the PID setpoint to <i>b5-58</i> to <i>b5-60</i> [PID Setpoint 2 to 4]. |

Refer to "b5-58 to b5-60: PID Setpoint 2 to 4" for more information.

### ■ 40: Forward RUN (2-Wire)

| Setting Value | Function             | Description   |
|---------------|----------------------|---|
| 40            | Forward RUN (2-Wire) | <div style="display: flex; justify-content: space-between; align-items: center;"> <span>V/f</span> <span>CL-V/f</span> <span>OLV</span> <span>CLV</span> <span>AOLV</span> <span>OLV/PM</span> <span>AOLV/PM</span> <span>CLV/PM</span> <span>EZOLV</span> </div> <p>Sets the Forward Run command for 2-wire sequence 1. Set this function and <math>HI-xx = 41</math> [Reverse Run Command (2-Wire Seq)] together.</p> |

**ON :** Forward Run

**OFF :** Run Stop

**Note:**

- Turning ON the Forward Run command terminal and the Reverse Run command terminal will cause alarm *EF* [FWD/REV Run Command Input Error] and the motor will ramp to stop.
- Initialize the drive with a 2-wire sequence to set the Forward Run command to terminal S1.
- This function will not operate at the same time as  $HI-xx = 42, 43$  [Run Command/FWD/REV Command (2-Wire Seq 2)].

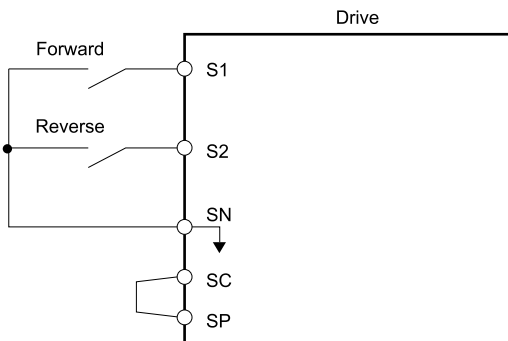


Figure 2.84 2-Wire Sequence Wiring Example

### ■ 41: Reverse RUN (2-Wire)

| Setting Value | Function             | Description   |
|---------------|----------------------|---|
| 41            | Reverse RUN (2-Wire) | <div style="display: flex; justify-content: space-between; align-items: center;"> <span>V/f</span> <span>CL-V/f</span> <span>OLV</span> <span>CLV</span> <span>AOLV</span> <span>OLV/PM</span> <span>AOLV/PM</span> <span>CLV/PM</span> <span>EZOLV</span> </div> <p>Sets the Forward Run command for 2-wire sequence 1. Set this function and <math>HI-xx = 40</math> [Forward Run Command (2-Wire Seq)] together.</p> |

**ON :** Reverse Run

**OFF :** Run Stop

**Note:**

- Turning ON the Forward Run command terminal and the Reverse Run command terminal will cause alarm *EF* [FWD/REV Run Command Input Error] and the motor will ramp to stop.
- Initialize the drive with a 2-wire sequence to set the Reverse Run command to terminal S2.
- This function will not operate at the same time as  $HI-xx = 42, 43$  [Run Command/FWD/REV Command (2-Wire Seq 2)].

### ■ 42: Run Command (2-Wire Sequence 2)

| Setting Value | Function                        | Description   |
|---------------|---------------------------------|---|
| 42            | Run Command (2-Wire Sequence 2) | <div style="display: flex; justify-content: space-between; align-items: center;"> <span>V/f</span> <span>CL-V/f</span> <span>OLV</span> <span>CLV</span> <span>AOLV</span> <span>OLV/PM</span> <span>AOLV/PM</span> <span>CLV/PM</span> <span>EZOLV</span> </div> <p>Sets the Run command for 2-wire sequence 2. Set this function and <math>HI-xx = 43</math> [FWD/REV Command (2-Wire Seq 2)] together.</p> |

**ON :** Run

**OFF :** Stop

**Note:**

This function will not operate at the same time as  $HI-xx = 40, 41$  [Forward/Reverse Run Command (2-Wire Seq)].

### ■ 43: FWD/REV (2-Wire Sequence 2)

| Setting Value | Function                    | Description  |
|---------------|-----------------------------|--|
| 43            | FWD/REV (2-Wire Sequence 2) | <div style="display: flex; justify-content: space-between; align-items: center;"> <span>V/f</span> <span>CL-V/f</span> <span>OLV</span> <span>CLV</span> <span>AOLV</span> <span>OLV/PM</span> <span>AOLV/PM</span> <span>CLV/PM</span> <span>EZOLV</span> </div> <p>Sets the direction of motor rotation for 2-wire sequence 2. Set this function and <math>HI-xx = 42</math> [Run Command (2-Wire Sequence 2)] together.</p> |

## 2.8 H: Terminal Functions

**ON : Reverse**

**OFF : Forward**

**Note:**

- You must input the Run command to rotate the motor.
- This function will not operate at the same time as  $H1-xx = 40, 41$  [Forward/Reverse Run Command (2-Wire Seq)].

### 44: Add Offset Frequency 1 (d7-01)

| Setting Value | Function           | Description  |
|---------------|--------------------|--|
| 44            | Offset Frequency 1 | <div style="display: flex; justify-content: space-between; font-size: 0.8em;"> <span>V/f</span> <span>CL-V/f</span> <span>OLV</span> <span>CLV</span> <span>AOLV</span> <span>OLV/PM</span> <span>AOLV/PM</span> <span>CLV/PM</span> <span>EZOLV</span> </div> <p>Sets the function to add the offset frequency set in <i>d7-01</i> [Offset Frequency 1] to the frequency reference when the terminal activates.</p> |

**Note:**

Refer to “d7: Offset Frequency” for more information.

### 45: Add Offset Frequency 2 (d7-02)

| Setting Value | Function           | Description  |
|---------------|--------------------|--|
| 45            | Offset Frequency 2 | <div style="display: flex; justify-content: space-between; font-size: 0.8em;"> <span>V/f</span> <span>CL-V/f</span> <span>OLV</span> <span>CLV</span> <span>AOLV</span> <span>OLV/PM</span> <span>AOLV/PM</span> <span>CLV/PM</span> <span>EZOLV</span> </div> <p>Sets the function to add the offset frequency set in <i>d7-02</i> [Offset Frequency 2] to the frequency reference when the terminal activates.</p> |

**Note:**

Refer to “d7: Offset Frequency” for more information.

### 46: Add Offset Frequency 3 (d7-03)

| Setting Value | Function           | Description  |
|---------------|--------------------|--|
| 46            | Offset Frequency 3 | <div style="display: flex; justify-content: space-between; font-size: 0.8em;"> <span>V/f</span> <span>CL-V/f</span> <span>OLV</span> <span>CLV</span> <span>AOLV</span> <span>OLV/PM</span> <span>AOLV/PM</span> <span>CLV/PM</span> <span>EZOLV</span> </div> <p>Sets the function to add the offset frequency set in <i>d7-03</i> [Offset Frequency 3] to the frequency reference when the terminal activates.</p> |

**Note:**

Refer to “d7: Offset Frequency” for more information.

### 47: Node Setup (CANopen)

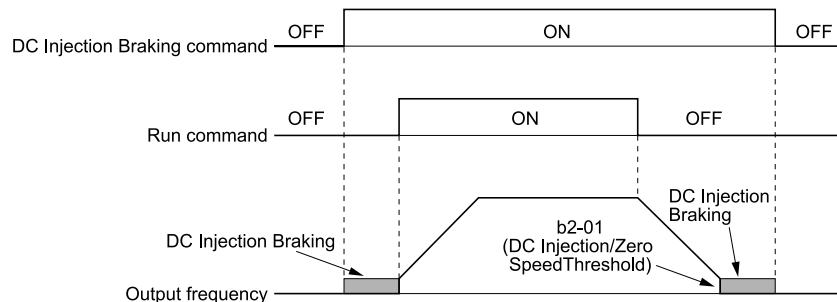
| Setting Value | Function             | Description  |
|---------------|----------------------|--|
| 47            | Node Setup (CANopen) | <div style="display: flex; justify-content: space-between; font-size: 0.8em;"> <span>V/f</span> <span>CL-V/f</span> <span>OLV</span> <span>CLV</span> <span>AOLV</span> <span>OLV/PM</span> <span>AOLV/PM</span> <span>CLV/PM</span> <span>EZOLV</span> </div> <p>Sets the function in CANopen communications to start the Node Setup function to set the drive node address from the host controller.</p> |

### 60: DC Injection Braking Command

| Setting Value | Function                     | Description   |
|---------------|------------------------------|---|
| 60            | DC Injection Braking Command | <div style="display: flex; justify-content: space-between; font-size: 0.8em;"> <span>V/f</span> <span>CL-V/f</span> <span>OLV</span> <span>CLV</span> <span>AOLV</span> <span>OLV/PM</span> <span>AOLV/PM</span> <span>CLV/PM</span> <span>EZOLV</span> </div> <p>Sets the command to use DC Injection Braking to stop the motor.</p> |

If you input the Run command or JOG command, it will cancel DC Injection Braking.

Figure 2.85 shows the time chart of the DC Injection Braking function.



**Figure 2.85 DC Injection Braking Time Chart**

**Note:**

- When  $A1-02 = 8$  [Control Method Selection = EZOLV], this function is available only if you use a PM motor.
- For details, refer to "b2: DC Injection Braking and Short Circuit Braking".

### 61: Speed Search from Fmax

| Setting Value | Function               | Description  |
|---------------|------------------------|--|
| 61            | Speed Search from Fmax | <div style="display: flex; justify-content: space-between; align-items: center;"> <span>V/f</span> <span>CL-V/f</span> <span>OLV</span> <span>CLV</span> <span>AOLV</span> <span>OLV/PM</span> <span>AOLV/PM</span> <span>CLV/PM</span> <span>EZOLV</span> </div> Sets the function to start speed search using an external reference although $b3-01 = 0$ [Speed Search Selection at Start = Disabled]. |

When the terminal is turned ON for  $b3-24 = 2$  [Speed Search Method Selection = Current Detection 2], the drive starts speed search from the maximum output frequency.

**Note:**

- The drive will detect  $oPE03$  [Multi-Function Input Setting Err] when  $H1-xx = 61$  and  $62$  are set at the same time.
- Refer to "b3: Speed Search" for more information.

### 62: Speed Search from Fref

| Setting Value | Function               | Description  |
|---------------|------------------------|--|
| 62            | Speed Search from Fref | <div style="display: flex; justify-content: space-between; align-items: center;"> <span>V/f</span> <span>CL-V/f</span> <span>OLV</span> <span>CLV</span> <span>AOLV</span> <span>OLV/PM</span> <span>AOLV/PM</span> <span>CLV/PM</span> <span>EZOLV</span> </div> Sets the function to start speed search using an external reference although $b3-01 = 0$ [Speed Search Selection at Start = Disabled]. |

When the terminal is turned ON for  $b3-24 = 2$  [Speed Search Method Selection = Current Detection 2], the drive starts speed search from the frequency reference.

**Note:**

- The drive will detect  $oPE03$  [Multi-Function Input Setting Err] when  $H1-xx = 61$  and  $62$  are set at the same time.
- Refer to "b3: Speed Search" for more information.

### 63: Field Weakening

| Setting Value | Function        | Description   |
|---------------|-----------------|---|
| 63            | Field Weakening | <div style="display: flex; justify-content: space-between; align-items: center;"> <span>V/f</span> <span>CL-V/f</span> <span>OLV</span> <span>CLV</span> <span>AOLV</span> <span>OLV/PM</span> <span>AOLV/PM</span> <span>CLV/PM</span> <span>EZOLV</span> </div> Sets the function to send the Field Weakening Level and Field Weakening Frequency Limit commands set in $d6-01$ [Field Weakening Level] and $d6-02$ [Field Weakening Frequency Limit] when the input terminal is activated. |

**Note:**

Refer to "d6: Field Weak & Field Force" for more information.

### 65: KEB Ride-Thru 1 Activate (N.C.)

| Setting Value | Function                        | Description   |
|---------------|---------------------------------|---|
| 65            | KEB Ride-Thru 1 Activate (N.C.) | <div style="display: flex; justify-content: space-between; align-items: center;"> <span>V/f</span> <span>CL-V/f</span> <span>OLV</span> <span>CLV</span> <span>AOLV</span> <span>OLV/PM</span> <span>AOLV/PM</span> <span>CLV/PM</span> <span>EZOLV</span> </div> Sets operation of the KEB1 function through the KEB Ride-Thru 1 (N.C.). |

**ON : Normal operation**

**OFF : Deceleration during momentary power loss**

When you enable KEB Ride-Thru 1, set  $L2-29$  [KEB Method Selection]. The drive operates with the selected KEB method.

**Note:**

- If you set *KEB Ride-Thru 1* [ $H1-xx = 65, 66$ ] and *KEB Ride-Thru 2* [ $H1-xx = 7A, 7B$ ] at the same time, the drive will detect  $oPE03$  [Multi-Function Input Setting Err].
- Refer to "KEB Ride-Thru function" for more information.

### 66: KEB Ride-Thru 1 Activate (N.O.)

| Setting Value | Function                        | Description   |
|---------------|---------------------------------|---|
| 66            | KEB Ride-Thru 1 Activate (N.O.) | <div style="display: flex; justify-content: space-between; align-items: center;"> <span>V/f</span> <span>CL-V/f</span> <span>OLV</span> <span>CLV</span> <span>AOLV</span> <span>OLV/PM</span> <span>AOLV/PM</span> <span>CLV/PM</span> <span>EZOLV</span> </div> Sets operation of the KEB1 function through the KEB Ride-Thru 1 (N.O.). |

**ON : Deceleration during momentary power loss**

**OFF : Normal operation**

## 2.8 H: Terminal Functions

When you enable KEB Ride-Thru 1, set *L2-29 [KEB Method Selection]*. The drive operates with the selected KEB method.

**Note:**

- If you set *KEB Ride-Thru 1 [H1-xx = 65, 66]* and *KEB Ride-Thru 2 [H1-xx = 7A, 7B]* at the same time, the drive will detect *oPE03 [Multi-Function Input Setting Err]*.
- Refer to "KEB Ride-Thru function" for more information.

### 67: Communications Test Mode

| Setting Value | Function                 | Description  |
|---------------|--------------------------|--|
| 67            | Communications Test Mode | <div style="display: flex; justify-content: space-between; align-items: center;"> <span>V/f</span> <span>CL-V/f</span> <span>OLV</span> <span>CLV</span> <span>AOLV</span> <span>OLV/PM</span> <span>AOLV/PM</span> <span>CLV/PM</span> <span>EZOLV</span> </div> <p>Set the function for the drive to self-test RS-485 serial communications operation.</p> |

The Self-Diagnostics function connects the transmission terminal of the control terminal block to the reception terminal. The function transmits the data that the drive sent to make sure that the drive can communicate correctly.

**Note:**

Refer to MEMOBUS/Modbus communications "Self-Diagnostics" for the self-diagnostics procedure.

### 68: High Slip Braking (HSB) Activate

| Setting Value | Function          | Description   |
|---------------|-------------------|---|
| 68            | High Slip Braking | <div style="display: flex; justify-content: space-between; align-items: center;"> <span>V/f</span> <span>CL-V/f</span> <span>OLV</span> <span>CLV</span> <span>AOLV</span> <span>OLV/PM</span> <span>AOLV/PM</span> <span>CLV/PM</span> <span>EZOLV</span> </div> <p>Sets the command to use high-slip braking to stop the motor.</p> |

**Note:**

- When you restart the drive after you use high-slip braking, make sure that the drive fully stops the motor then clear the high-slip braking input.
- Refer to "n3: High Slip/Overex Braking" for more information.

### 6A: Drive Enable

| Setting Value | Function     | Description   |
|---------------|--------------|---|
| 6A            | Drive Enable | <div style="display: flex; justify-content: space-between; align-items: center;"> <span>V/f</span> <span>CL-V/f</span> <span>OLV</span> <span>CLV</span> <span>AOLV</span> <span>OLV/PM</span> <span>AOLV/PM</span> <span>CLV/PM</span> <span>EZOLV</span> </div> <p>Sets the function to show <i>dnE [Drive Enabled]</i> on the keypad and ignore Run commands when the terminal is OFF.</p> |

If you input the Run command before you turn ON the Drive Enable terminal, you must input the Run command again to operate the drive. When the terminal set for Drive Enable is turned OFF when the drive is operating, the drive will use the stopping method set in *b1-03 [Stopping Method Selection]* to stop the motor.

**ON : Run command is accepted.**

**OFF : Run command is disabled. When the drive is running, it stops according to *b1-03* setting.**

### 71: Torque Control

| Setting Value | Function       | Description  |
|---------------|----------------|--|
| 71            | Torque Control | <div style="display: flex; justify-content: space-between; align-items: center;"> <span>V/f</span> <span>CL-V/f</span> <span>OLV</span> <span>CLV</span> <span>AOLV</span> <span>OLV/PM</span> <span>AOLV/PM</span> <span>CLV/PM</span> <span>EZOLV</span> </div> <p>Sets the function to switch between torque control and speed control.</p> |

**ON : Torque control**

**OFF : Speed control**

**Note:**

When this function is enabled, set *d5-01 = 0 [Torque Control Selection = Speed Control]*.

#### Input the Speed/Torque Control Switchover Time

Use parameter *d5-06 [Speed/Torque Changeover Time]* to set the length of time, in milliseconds, that the drive will wait to switch between speed and torque control. When the speed/torque control switchover signal changes in the time set in *d5-06*, the three analog inputs will keep their present value. Complete the signal switchover with an external source in this time.

**Note:**

Refer to "Switch Speed Control and Torque Control" for more information.

■ 72: Zero Servo

| Setting Value | Function   | Description   |
|---------------|------------|---|
| 72            | Zero Servo | <div style="display: flex; justify-content: space-between; align-items: center;"> <span>V/f</span> <span>CL-V/f</span> <span>OLV</span> <span style="background-color: #ccc; border: 1px solid #000; padding: 2px;">CLV</span> <span>AOLV</span> <span>OLV/PM</span> <span>AOLV/PM</span> <span style="background-color: #ccc; border: 1px solid #000; padding: 2px;">CLV/PM</span> <span>EZOLV</span> </div> <p>Sets the function to hold a stopped motor.</p> |

This function will hold a stopped motor if an external force is applied or an analog reference is offset.

**Note:**

- Refer to “b9: Zero Servo” for more information.
- When you use the Zero Servo function, keep the Run command ON. Zero servo stops the motor and if you turn OFF the Run command, it will not have power.

■ 75: Up 2 Command

| Setting Value | Function     | Description  |
|---------------|--------------|--|
| 75            | Up 2 Command | <div style="display: flex; justify-content: space-between; align-items: center;"> <span>V/f</span> <span>CL-V/f</span> <span>OLV</span> <span style="background-color: #ccc; border: 1px solid #000; padding: 2px;">CLV</span> <span>AOLV</span> <span>OLV/PM</span> <span>AOLV/PM</span> <span style="background-color: #ccc; border: 1px solid #000; padding: 2px;">CLV/PM</span> <span>EZOLV</span> </div> <p>Sets the function to increase the frequency reference bias value to accelerate the motor when the terminal is activated. Set this function and <i>H1-xx = 76 [Down 2 Command]</i> together.</p> |

When you activate the terminal set for Up2 Command, the bias will increase. When you activate the terminal set for Down 2 Command, the bias will decrease. When you activate or deactivate the two commands, the drive will hold the frequency reference. Table 2.59 gives information about the relation between operation of the Up/Down 2 Command and *d4-01, d4-03, d4-05*.

**Note:**

- When using this function, set the optimal bias limit value with *d4-08* and *d4-09 [Up/Down 2 Bias Upper Limit/Lower Limit]*.
- For more information, refer to "d4: Frequency Ref Up/Down & Hold".

**Table 2.59 Up 2 Command, Down 2 Command**

| Function | Frequency Reference Source | d4-03 | d4-05 | d4-01 | Operation   | Storing the Frequency Reference or Frequency Bias  |
|----------|----------------------------|-------|-------|-------|---|--|
| 1        | Multi-step speed reference | 0.00  | 0     | 0     | <ul style="list-style-type: none"> <li>• When the Up 2 Command is active, the drive accelerates the motor (increases the bias value).</li> <li>• When the Down 2 Command is active, the drive decelerates the motor (decreases the bias value)</li> <li>• When the Up 2 Command and Down 2 Command are not active and when the Up 2 Command and Down 2 Command are active, the drive holds the output frequency (holds the bias value).</li> <li>• When the frequency changes, it will reset the bias.</li> <li>• For all other statuses, the drive will follow the frequency reference.</li> </ul>   | Not stored.  |
| 2        |                            |       |       | 1     |   | When the bias value and frequency reference are constant for 5 seconds after the frequency reference hold starts, the drive will add the bias value to the enabled frequency reference, then reset.  |
| 3        |                            |       |       | -     |   | <ul style="list-style-type: none"> <li>• When the Up 2 Command is active, the drive accelerates the motor.</li> <li>• When the Down 2 Command is active, the drive decelerates the motor.</li> <li>• For all other statuses, the drive will follow the frequency reference.</li> </ul> |
| 4        | Multi-step speed reference | > 0   | -     | 0     | <ul style="list-style-type: none"> <li>• When the Up 2 Command is active, the drive accelerates the motor to "Frequency Reference + <i>d4-03</i>" (the bias value will increase to the value set in <i>d4-03</i>)</li> <li>• When the Down 2 Command is active, the drive decelerates the motor to "Frequency Reference - <i>d4-03</i>" (the bias value will decrease to the value set in <i>d4-03</i>).</li> <li>• When the Up 2 Command and Down 2 Command are not active and when the Up 2 Command and Down 2 Command are active, the drive holds the output frequency (holds the bias value).</li> <li>• When the frequency changes, it will reset the bias.</li> <li>• For all other statuses, the drive will follow the frequency reference.</li> </ul> | Not stored.  |
| 5        |                            |       |       | 1     |   | When the bias value and frequency reference are constant for 5 seconds after the frequency reference hold starts, the drive will add the bias value to the enabled frequency reference, then reset.  |

Parameter Details

## 2.8 H: Terminal Functions

| Function | Frequency Reference Source             | d4-03 | d4-05 | d4-01 | Operation  | Storing the Frequency Reference or Frequency Bias  |
|----------|--|-------|-------|-------|--|--|
| 6        | Others<br>(Analog input, transmission) | 0     | 0     | 0     | <ul style="list-style-type: none"> <li>When the Up 2 Command is active, the drive accelerates the motor (increases the bias value).</li> <li>When the Down 2 Command is active, the drive decelerates the motor (decreases the bias value)</li> <li>When the Up 2 Command and Down 2 Command are not active and when the Up 2 Command and Down 2 Command are active, the drive holds the output frequency (holds the bias value).</li> <li>During acceleration or deceleration, when the frequency reference increases or decreases more than <i>d4-07</i>, the drive holds the bias value until the output frequency and the actual frequency reference agree (speed agreement).</li> </ul> | Not stored.  |
| 7        |  |       |       | 1     |  | When the bias value is constant for 5 seconds after the frequency reference hold starts, the drive will store the bias value in <i>d4-06</i> . You cannot rewrite the frequency reference is not possible. The drive will store only the bias value. |
| 8        | Others<br>(Analog input, transmission) | 0     | 1     | -     | <ul style="list-style-type: none"> <li>When the Up 2 Command is active, the drive accelerates the motor (increases the bias value).</li> <li>When the Down 2 Command is active, the drive decelerates the motor (decreases the bias value)</li> <li>For all other statuses, the drive will follow the frequency reference.</li> </ul>  | Not stored.  |
| 9        |  |       |       | 0     |  | When the bias value is constant for 5 seconds after the frequency reference hold starts, the drive will store the bias value in <i>d4-06</i> . You cannot rewrite the frequency reference is not possible. The drive will store only the bias value. |
| 10       |  | > 0   | -     | 1     | <ul style="list-style-type: none"> <li>When the Up 2 Command is active, the drive accelerates the motor to "Frequency Reference + <i>d4-03</i>" (the bias value will increase to the value set in <i>d4-03</i>)</li> <li>When the Down 2 Command is active, the drive decelerates the motor to "Frequency Reference - <i>d4-03</i>" (the bias value will decrease to the value set in <i>d4-03</i>).</li> <li>During acceleration or deceleration, when the frequency reference increases or decreases more than <i>d4-07</i>, the drive holds the bias value until the output frequency and the actual frequency reference agree (speed agreement).</li> </ul>                              | Not stored.  |

### 76: Down 2 Command

| Setting Value | Function       | Description  |
|---------------|----------------|--|
| 76            | Down 2 Command | <p><b>V/f</b> <b>CL-V/f</b> <b>OLV</b> <b>CLV</b> <b>AOLV</b> <b>OLV/PM</b> <b>AOLV/PM</b> <b>CLV/PM</b> <b>EZOLV</b></p> <p>Sets the function to decrease the frequency reference bias value to decelerate the motor when the terminal is activated. Set this function and <i>H1-xx = 75 [Up 2 Command]</i> together.</p> |

When you activate the terminal set for Up2 Command, the bias will increase. When you activate the terminal set for Down 2 Command, the bias will decrease. When you activate or deactivate the two commands, the drive will hold the frequency reference.

**Note:**

- When using this function, set the optimal bias limit value with *d4-08* and *d4-09 [Up/Down 2 Bias Upper Limit/Lower Limit]*.
- Refer to "d4: Frequency Ref Up/Down & Hold" for more information.

### 77: ASR Gain (C5-03) Select

| Setting Value | Function                | Description  |
|---------------|-------------------------|--|
| 77            | ASR Gain (C5-03) Select | <p><b>V/f</b> <b>CL-V/f</b> <b>OLV</b> <b>CLV</b> <b>AOLV</b> <b>OLV/PM</b> <b>AOLV/PM</b> <b>CLV/PM</b> <b>EZOLV</b></p> <p>Sets the function to switch the ASR proportional gain set in <i>C5-01 [ASR Proportional Gain 1]</i> and <i>C5-03 [ASR Proportional Gain 2]</i>.</p> |

**ON : C5-03**

Switches the proportional gain to *C5-03 [ASR Proportional Gain 2]*.

**OFF : C5-01**

Switches the proportional gain to *C5-01 [ASR Proportional Gain 1]*.

**Note:**

Refer to "C5: Automatic Speed Regulator (ASR)" for more information.

### 78: Analog TorqueRef Polarity Invert

| Setting Value | Function                         | Description  |
|---------------|----------------------------------|--|
| 78            | Analog TorqueRef Polarity Invert | <p><b>V/f</b> <b>CL-V/f</b> <b>OLV</b> <b>CLV</b> <b>AOLV</b> <b>OLV/PM</b> <b>AOLV/PM</b> <b>CLV/PM</b> <b>EZOLV</b></p> <p>Sets the rotation direction of the external torque reference.</p> |



**ON : External torque reference reverse direction**

**OFF : External torque reference forward direction**

### ■ 7A: KEB Ride-Thru 2 Activate (N.C.)

| Setting Value | Function                        | Description  |
|---------------|---------------------------------|--|
| 7A            | KEB Ride-Thru 2 Activate (N.C.) | <div style="display: flex; gap: 5px;"> <span>V/f</span> <span>CL-V/f</span> <span>OLV</span> <span>CLV</span> <span>AOLV</span> <span>OLV/PM</span> <span>AOLV/PM</span> <span>CLV/PM</span> <span>EZOLV</span> </div> Sets operation of the KEB2 function through the KEB Ride-Thru 2 (N.C.). |

**ON : Normal operation**

**OFF : Deceleration during momentary power loss**

When KEB Ride-Thru 2 is input, the drive will use Single Drive KEB Ride-Thru 2 for KEB operation. The *L2-29 [KEB Method Selection]* setting will not have an effect.

**Note:**

- If you set *KEB Ride-Thru 1 [H1-xx = 65, 66]* and *KEB Ride-Thru 2 [H1-xx = 7A, 7B]* at the same time, the drive will detect *oPE03 [Multi-Function Input Setting Err]*.
- Refer to "KEB Ride-Thru function" for more information.

### ■ 7B: KEB Ride-Thru 2 Activate (N.O.)

| Setting Value | Function                        | Description  |
|---------------|---------------------------------|--|
| 7B            | KEB Ride-Thru 2 Activate (N.O.) | <div style="display: flex; gap: 5px;"> <span>V/f</span> <span>CL-V/f</span> <span>OLV</span> <span>CLV</span> <span>AOLV</span> <span>OLV/PM</span> <span>AOLV/PM</span> <span>CLV/PM</span> <span>EZOLV</span> </div> Sets operation of the KEB2 function through the KEB Ride-Thru 2 (N.O.). |

**ON : Deceleration during momentary power loss**

**OFF : Normal operation**

When KEB Ride-Thru 2 is input, the drive will use Single Drive KEB Ride-Thru 2 for KEB operation. The *L2-29 [KEB Method Selection]* setting will not have an effect.

**Note:**

- If you set *KEB Ride-Thru 1 [H1-xx = 65, 66]* and *KEB Ride-Thru 2 [H1-xx = 7A, 7B]* at the same time, the drive will detect *oPE03 [Multi-Function Input Setting Err]*.
- Refer to "KEB Ride-Thru function" for more information.

### ■ 7C: Short Circuit Braking (N.O.)

| Setting Value | Function                     | Description  |
|---------------|------------------------------|--|
| 7C            | Short Circuit Braking (N.O.) | <div style="display: flex; gap: 5px;"> <span>V/f</span> <span>CL-V/f</span> <span>OLV</span> <span>CLV</span> <span>AOLV</span> <span>OLV/PM</span> <span>AOLV/PM</span> <span>CLV/PM</span> <span>EZOLV</span> </div> Sets operation of Short Circuit Braking (N.O.). |

The drive will generate braking torque in the spinning motor by short-circuiting the three phases of a PM motor.

**Note:**

- When *A1-02 = 8 [Control Method Selection = EZOLV]*, this function is available only if you use a PM motor.
- For details, refer to "b2: DC Injection Braking and Short Circuit Braking".

**ON : Short Circuit Braking is enabled.**

**OFF : Normal operation**

### ■ 7D: Short Circuit Braking (N.C.)

| Setting Value | Function                     | Description  |
|---------------|------------------------------|--|
| 7D            | Short Circuit Braking (N.C.) | <div style="display: flex; gap: 5px;"> <span>V/f</span> <span>CL-V/f</span> <span>OLV</span> <span>CLV</span> <span>AOLV</span> <span>OLV/PM</span> <span>AOLV/PM</span> <span>CLV/PM</span> <span>EZOLV</span> </div> Sets operation of Short Circuit Braking (N.C.). |

The drive will generate braking torque in the spinning motor by short-circuiting the three phases of a PM motor.

**Note:**

- When *A1-02 = 8 [Control Method Selection = EZOLV]*, this function is available only if you use a PM motor.
- For details, refer to "b2: DC Injection Braking and Short Circuit Braking".

**ON : Normal operation**

**OFF : Short Circuit Braking is enabled.**

■ **7E: Reverse Rotation Identifier**

| Setting Value | Function                    | Description   |
|---------------|-----------------------------|---|
| 7E            | Reverse Rotation Identifier | <div style="display: flex; justify-content: space-between; align-items: center;"> <span>V/f</span> <span>CL-V/f</span> <span>OLV</span> <span>CLV</span> <span>AOLV</span> <span>OLV/PM</span> <span>AOLV/PM</span> <span>CLV/PM</span> <span>EZOLV</span> </div> <p>Sets the rotation direction of the motor when in Simple Closed Loop V/f Control method and <math>F1-21, F1-37 = 0</math> [Encoder Option Function Selection = A pulse detection], or when in Closed Loop V/f Control method.</p> |

**ON : Reverse run**

The drive recognizes that the motor is rotating in reverse direction.

**OFF : Forward run**

The drive recognizes that the motor is rotating in forward direction.

■ **90 to 97: DriveWorksEZ Digital Inputs 1 to 8**

| Setting Value | Function                   | Description  |
|---------------|----------------------------|--|
| 90 - 97       | DWEZ Digital Inputs 1 to 8 | <div style="display: flex; justify-content: space-between; align-items: center;"> <span>V/f</span> <span>CL-V/f</span> <span>OLV</span> <span>CLV</span> <span>AOLV</span> <span>OLV/PM</span> <span>AOLV/PM</span> <span>CLV/PM</span> <span>EZOLV</span> </div> <p>Sets digital inputs used with DriveWorksEZ. Refer to the DriveWorksEZ online manual for more information.</p> |

**Note:**

You cannot set values 90 to 97 for inverse output.

■ **9F: DWEZ Disable**

| Setting Value | Function     | Description   |
|---------------|--------------|---|
| 9F            | DWEZ Disable | <div style="display: flex; justify-content: space-between; align-items: center;"> <span>V/f</span> <span>CL-V/f</span> <span>OLV</span> <span>CLV</span> <span>AOLV</span> <span>OLV/PM</span> <span>AOLV/PM</span> <span>CLV/PM</span> <span>EZOLV</span> </div> <p>Sets operation of the DriveWorksEZ program saved in the drive.</p> |

**Note:**

Set  $A1-07 = 2$  [DriveWorksEZ Function Selection = Digital input] to use this function.

**ON : Disabled**

**OFF : Enabled**

■ **101 to 19F: Inverse Input of 1 to 9F**

| Setting Value | Function                 | Description   |
|---------------|--------------------------|---|
| 101 to 19F    | Inverse Input of 1 to 9F | Sets the function of the selected MFDI to operate inversely. To select the function, enter "1xx", where the "xx" is the function setting value. |

For example, to use the inverse input of E [ASR Integral Reset], set  $H1-xx = 10E$ .

**Note:**

You cannot use inverse input for all functions. Refer to Table 2.55 for more information.

◆ **H2: Digital Outputs**

*H2 parameters* set the MFDO terminal functions.

■ **H2-01 to H2-03 Terminal M1-M2, M3-M4, M5-M6 Function Selection**

The drive has three MFDO terminals. Table 2.60 shows the default function settings for the terminals.

**Table 2.60 MFDO Terminals Default Function Settings**

| No.   | Name                           | Default | Function      |
|-------|--------------------------------|---------|---------------|
| H2-01 | Term M1-M2 Function Selection  | 0       | During Run    |
| H2-02 | Term M3-M4 Function Selection  | 1       | Zero Speed    |
| H2-03 | Terminal M5-M6 Function Select | 2       | Speed Agree 1 |

Refer to Table 2.61 to set  $H2-xx$  [MFDO Function Select].

Table 2.61 MFDO Setting Value

| Setting Value | Function                        | Reference | Setting Value | Function  | Reference |
|---------------|---------------------------------|-----------|---------------|---|-----------|
| 0             | During Run                      | 400       | 22            | Mechanical Weakening Detection  | 409       |
| 1             | Zero Speed                      | 400       | 2F            | Maintenance Notification  | 409       |
| 2             | Speed Agree 1                   | 401       | 30            | During Torque Limit   | 410       |
| 3             | User-Set Speed Agree 1          | 401       | 31            | During Speed Limit  | 410       |
| 4             | Frequency Detection 1           | 402       | 32            | In Speed Limit During Trq Ctrl  | 410       |
| 5             | Frequency Detection 2           | 402       | 33            | Zero Servo Complete   | 410       |
| 6             | Drive ready                     | 403       | 37            | During Frequency Output   | 410       |
| 7             | DC Bus Undervoltage             | 403       | 38            | Drive Enabled   | 411       |
| 8             | During Baseblock (N.O.)         | 403       | 39            | Watt Hour Pulse Output  | 411       |
| 9             | Frequency Reference from Keypad | 403       | 3C            | LOCAL Control Selected  | 411       |
| A             | Run Command Source              | 404       | 3D            | During Speed Search   | 411       |
| B             | Torque Detection 1 (N.O.)       | 404       | 3E            | PID Feedback Low  | 411       |
| C             | Frequency Reference Loss        | 404       | 3F            | PID Feedback High   | 412       |
| D             | Braking Resistor Fault          | 404       | 4A            | During KEB Ride-Thru  | 412       |
| E             | Faults                          | 404       | 4B            | During Short Circuit Braking  | 412       |
| F *1          | Not Used                        | 404       | 4C            | During Fast Stop  | 412       |
| 10            | Alarm                           | 404       | 4D            | oH Pre-Alarm Time Limit   | 412       |
| 11            | Fault Reset Command Active      | 405       | 4E *2         | Braking Transistor Fault (rr)   | 412       |
| 12            | Timer Output                    | 405       | 4F *2         | Braking Resistor Overheat (rH)  | 412       |
| 13            | Speed Agree 2                   | 405       | 60            | Internal Cooling Fan Alarm  | 413       |
| 14            | User-Set Speed Agree 2          | 405       | 61            | Pole Position Detection Complete  | 413       |
| 15            | Frequency Detection 3           | 406       | 62            | Modbus Reg 1 Status Satisfied   | 413       |
| 16            | Frequency Detection 4           | 406       | 63            | Modbus Reg 2 Status Satisfied   | 413       |
| 17            | Torque Detection 1 (N.C.)       | 407       | 65            | Standby Output  | 413       |
| 18            | Torque Detection 2 (N.O.)       | 407       | 66            | Comparator1   | 413       |
| 19            | Torque Detection 2 (N.C.)       | 407       | 67            | Comparator2   | 414       |
| 1A            | During reverse                  | 408       | 69            | External Power 24V Supply   | 414       |
| 1B            | During Baseblock (N.C.)         | 408       | 6A            | Data Logger Error   | 415       |
| 1C            | Motor 2 Selection               | 408       | 90 - 93       | DWEZ Digital Output 1 to 4  | 415       |
| 1D            | During Regeneration             | 408       | A0 to A7      | DWEZ Extended Digital Output 1 to 8   | 415       |
| 1E            | Executing Auto-Restart          | 408       | 100 to 1A7    | Inverse output of 0 to A7<br>Sets an inverse output of the function for the MFDO.<br>Put a 1 at the front of the function setting to set inverse output. For example, set 138 for inverse output of 38 [Drive Enabled]. | 415       |
| 1F            | Motor Overload Alarm (oL1)      | 409       |               |   |           |
| 20            | Drive Overheat Pre-Alarm (oH)   | 409       |               |   |           |
| 21            | Safety Monitor Output Status    | 409       |               |   |           |

\*1 Inverse output is not available.

\*2 You cannot set this parameter on models 2169 to 2415 and 4089 to 4720.

### ■ Extend MFDO1 to MFDO3 Function Selection

You can set MFDO functions to *bit 0 to bit 2* [MEMOBUS MFDO1 to 3] of MEMOBUS register 15E0 (Hex.). Use H2-40 to H2-42 [Mbus Reg 15E0h bit0 to bit2 Output Func] to select the function.

## 2.8 H: Terminal Functions

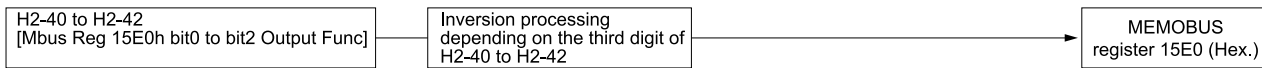


Figure 2.86 Functional Block Diagram of MEMOBUS Multi-function Output

Table 2.62 MEMOBUS MFDO Registers

| Register No.<br>(Hex.) | Name |                |
|------------------------|------|----------------|
| 15E0                   | bit0 | MEMOBUS MFDO 1 |
|                        | bit1 | MEMOBUS MFDO 2 |
|                        | bit2 | MEMOBUS MFDO 3 |

**Note:**

- Refer to H2-xx “MFDO Setting Values” for more information about MFDO setting values.
- When you do not set functions to H2-40 to H2-42, set them to F.

### Output of Logical Operation Results of MFDO

This enables the logical operation results of two MFDOs to be output to one MFDO terminal.

Use H2-60, H2-63, and H2-66 [Term M1-M2 Secondary Function to Term M5-M6 Secondary Function] to set the function of the output signal for which logical operations are performed.

Use H2-61, H2-64, H2-67 [Term M1-M2 Logical Operation to Term M5-M6 Logical Operation] to set the logical operation.

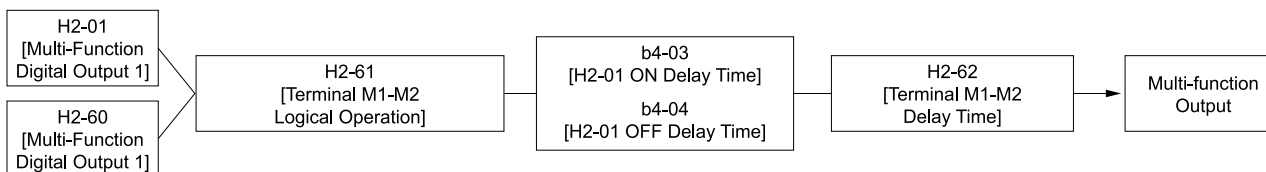


Figure 2.87 Functional Block Diagram of Logical Operation Output for MFDO 1

Table 2.63 MFDO Logical Operation Table

| Logical Operation Selection | Logical Operation Expression | Logical Operation Notation |
|-----------------------------|------------------------------|----------------------------|
| H2-61, H2-64, H2-67         |                              |                            |
| 0                           | $A=B=1$                      |                            |
| 1                           | $A=1 \text{ or } B=1$        |                            |
| 2                           | $A=0 \text{ or } B=0$        |                            |
| 3                           | $A=B=0$                      |                            |
| 4                           | $A=B$                        | $A=B$                      |
| 5                           | $A \neq B$                   |                            |
| 6                           | $AND(A, \bar{B})$            |                            |
| 7                           | $OR(A, \bar{B})$             |                            |
| 8                           | -                            | On                         |

**Note:**

- When you use the function to output logical calculation results, you cannot set H2-01 to H2-03 = 1xx [Inverse Output of xx]. If you do, the drive will detect oPE33 [Digital Output Selection Error].
- When you do not use H2-60, H2-63, and H2-66, set them to F. The through mode function is not supported.

◆ **H2 MFDO Parameters**

■ **H2-01: Term M1-M2 Function Selection**

| No. (Hex.)   | Name                          | Description  | Default (Range) |
|--------------|-------------------------------|--|-----------------|
| H2-01 (040B) | Term M1-M2 Function Selection | <span>V/f</span> <span>CL-V/f</span> <span>OLV</span> <span>CLV</span> <span>AOLV</span> <span>OLV/PM</span> <span>AOLV/PM</span> <span>CLV/PM</span> <span>EZOLV</span><br>Sets the function for MFDO terminal M1-M2. | 0<br>(0 - 1FF)  |

**Note:**

Set this parameter to F when the terminal is not being used or to use the terminal in through mode.

■ **H2-02: Term M3-M4 Function Selection**

| No. (Hex.)   | Name                          | Description  | Default (Range) |
|--------------|-------------------------------|--|-----------------|
| H2-02 (040C) | Term M3-M4 Function Selection | <span>V/f</span> <span>CL-V/f</span> <span>OLV</span> <span>CLV</span> <span>AOLV</span> <span>OLV/PM</span> <span>AOLV/PM</span> <span>CLV/PM</span> <span>EZOLV</span><br>Sets the function for MFDO terminal M3-M4. | 1<br>(0 - 1FF)  |

**Note:**

Set this parameter to F when not using the terminal or to use the terminal in through mode.

■ **H2-03: Term M5-M6 Function Selection**

| No. (Hex.)   | Name                          | Description  | Default (Range) |
|--------------|-------------------------------|--|-----------------|
| H2-03 (040D) | Term M5-M6 Function Selection | <span>V/f</span> <span>CL-V/f</span> <span>OLV</span> <span>CLV</span> <span>AOLV</span> <span>OLV/PM</span> <span>AOLV/PM</span> <span>CLV/PM</span> <span>EZOLV</span><br>Sets the function for MFDO terminal M5-M6. | 2<br>(0 - 1FF)  |

**Note:**

Set this parameter to F when not using the terminal or to use the terminal in through mode.

■ **H2-06: Watt Hour Output Unit Selection**

| No. (Hex.)   | Name                            | Description  | Default (Range) |
|--------------|---------------------------------|--|-----------------|
| H2-06 (0437) | Watt Hour Output Unit Selection | <span>V/f</span> <span>CL-V/f</span> <span>OLV</span> <span>CLV</span> <span>AOLV</span> <span>OLV/PM</span> <span>AOLV/PM</span> <span>CLV/PM</span> <span>EZOLV</span><br>Sets the unit for the output signal when H2-01 to H2-03 = 39 [MFDO Function Selection = Watt Hour Pulse Output]. | 0<br>(0 - 4)    |

This output is input to the Watt hour meter or PLC through a 200 ms pulse signal. This parameter sets the kWh unit for each pulse output.

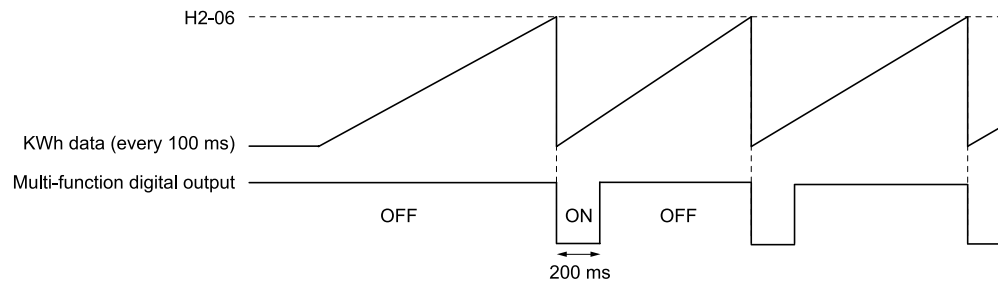


Figure 2.88 Example MFDO when Configured for Watt Hours

**Note:**

- When the power value is a negative value (regenerative state), the drive does not count Watt hours.
- When the control power supply to the drive is operating, the drive will keep the Watt hours. If a momentary power loss causes the drive to lose control power, the Watt hour count will reset.

## 2.8 H: Terminal Functions

0 : 0.1 kWh units

1 : 1 kWh units

2 : 10 kWh units

3 : 100 kWh units

4 : 1000 kWh units

### ■ H2-07: Modbus Register 1 Address Select

| No.<br>(Hex.)   | Name                             | Description  | Default<br>(Range)    |
|-----------------|----------------------------------|--|-----------------------|
| H2-07<br>(0B3A) | Modbus Register 1 Address Select | <input type="checkbox"/> V/f <input type="checkbox"/> CL-V/f <input type="checkbox"/> OLV <input type="checkbox"/> CLV <input type="checkbox"/> AOLV <input type="checkbox"/> OLV/PM <input type="checkbox"/> AOLV/PM <input type="checkbox"/> CLV/PM <input type="checkbox"/> EZOLV<br>Sets the address of the MEMOBUS/Modbus register output to the MFDO terminal. | 0001<br>(0001 - 1FFF) |

Sets the address of the register that is output to *Modbus Reg 1 Status Satisfied* [H2-01 to H2-03 = 62] and uses the bit in H2-08 [*Modbus Register 1 Bit Select*].

### ■ H2-08: Modbus Register 1 Bit Select

| No.<br>(Hex.)   | Name                         | Description  | Default<br>(Range)    |
|-----------------|------------------------------|--|-----------------------|
| H2-08<br>(0B3B) | Modbus Register 1 Bit Select | <input type="checkbox"/> V/f <input type="checkbox"/> CL-V/f <input type="checkbox"/> OLV <input type="checkbox"/> CLV <input type="checkbox"/> AOLV <input type="checkbox"/> OLV/PM <input type="checkbox"/> AOLV/PM <input type="checkbox"/> CLV/PM <input type="checkbox"/> EZOLV<br>Sets the bit of the MEMOBUS/Modbus register output to the MFDO terminal. | 0000<br>(0000 - FFFF) |

Sets the bit of the register that is output to *Modbus Reg 1 Status Satisfied* [H2-01 to H2-03 = 62] and uses the address in H2-07 [*Modbus Register 1 Address Select*].

### ■ H2-09: Modbus Register 2 Address Select

| No.<br>(Hex.)   | Name                             | Description  | Default<br>(Range)    |
|-----------------|----------------------------------|--|-----------------------|
| H2-09<br>(0B3C) | Modbus Register 2 Address Select | <input type="checkbox"/> V/f <input type="checkbox"/> CL-V/f <input type="checkbox"/> OLV <input type="checkbox"/> CLV <input type="checkbox"/> AOLV <input type="checkbox"/> OLV/PM <input type="checkbox"/> AOLV/PM <input type="checkbox"/> CLV/PM <input type="checkbox"/> EZOLV<br>Sets the address of the MEMOBUS/Modbus register output to the MFDO terminal. | 0001<br>(0001 - 1FFF) |

Sets H2-09 with the address of the register that is output to *Modbus Reg 2 Status Satisfied* [H2-01 to H2-03 = 63] and uses the bit in H2-10 [*Modbus Register 2 Bit Select*].

### ■ H2-10: Modbus Register 2 Bit Select

| No.<br>(Hex.)   | Name                         | Description  | Default<br>(Range)    |
|-----------------|------------------------------|--|-----------------------|
| H2-10<br>(0B3D) | Modbus Register 2 Bit Select | <input type="checkbox"/> V/f <input type="checkbox"/> CL-V/f <input type="checkbox"/> OLV <input type="checkbox"/> CLV <input type="checkbox"/> AOLV <input type="checkbox"/> OLV/PM <input type="checkbox"/> AOLV/PM <input type="checkbox"/> CLV/PM <input type="checkbox"/> EZOLV<br>Sets the bit of the MEMOBUS/Modbus register output to the MFDO terminal. | 0000<br>(0000 - FFFF) |

Sets the bit of the register that is output to *Modbus Reg 2 Status Satisfied* [H2-01 to H2-03 = 63] and uses the address in H2-09.

### ■ H2-20: Comparator 1 Monitor Selection

| No.<br>(Hex.)   | Name                           | Description   | Default<br>(Range) |
|-----------------|--------------------------------|---|--------------------|
| H2-20<br>(1540) | Comparator 1 Monitor Selection | <input type="checkbox"/> V/f <input type="checkbox"/> CL-V/f <input type="checkbox"/> OLV <input type="checkbox"/> CLV <input type="checkbox"/> AOLV <input type="checkbox"/> OLV/PM <input type="checkbox"/> AOLV/PM <input type="checkbox"/> CLV/PM <input type="checkbox"/> EZOLV<br>Sets the monitor number for comparator 1. Set the x-xx part of the Ux-xx [ <i>Monitor</i> ]. For example, set H2-20 = 102 to monitor U1-02 [ <i>Output Frequency</i> ]. | 102<br>(000 - 999) |

**Note:**

- For information on the comparator function, refer to 66: *Comparator1* on page 413 and 67: *Comparator2* on page 414.
- The configurable monitor changes when the control method changes.

### ■ H2-21: Comparator 1 Lower Limit

| No.<br>(Hex.)   | Name                     | Description   | Default<br>(Range)     |
|-----------------|--------------------------|---|------------------------|
| H2-21<br>(1541) | Comparator 1 Lower Limit | <b>V/f</b> <b>CL-V/f</b> <b>OLV</b> <b>CLV</b> <b>AOLV</b> <b>OLV/PM</b> <b>AOLV/PM</b> <b>CLV/PM</b> <b>EZOLV</b><br>Sets the lower limit detection level for comparator 1 when the full scale analog output for the monitor selected in H2-20 [Comparator 1 Monitor Selection] is the 100% value. | 0.0%<br>(0.0 - 300.0%) |

**Note:**

For information on the comparator function, refer to 66: *Comparator1* on page 413 and 67: *Comparator2* on page 414.

### ■ H2-22: Comparator 1 Upper Limit

| No.<br>(Hex.)   | Name                     | Description   | Default<br>(Range)     |
|-----------------|--------------------------|---|------------------------|
| H2-22<br>(1542) | Comparator 1 Upper Limit | <b>V/f</b> <b>CL-V/f</b> <b>OLV</b> <b>CLV</b> <b>AOLV</b> <b>OLV/PM</b> <b>AOLV/PM</b> <b>CLV/PM</b> <b>EZOLV</b><br>Sets the upper limit detection level for comparator 1 when the full scale analog output for the monitor selected in H2-20 [Comparator 1 Monitor Selection] is the 100% value. | 0.0%<br>(0.0 - 300.0%) |

**Note:**

For information on the comparator function, refer to 66: *Comparator1* on page 413 and 67: *Comparator2* on page 414.

### ■ H2-23: Comparator 1 Hysteresis

| No.<br>(Hex.)   | Name                    | Description  | Default<br>(Range)    |
|-----------------|-------------------------|--|-----------------------|
| H2-23<br>(1543) | Comparator 1 Hysteresis | <b>V/f</b> <b>CL-V/f</b> <b>OLV</b> <b>CLV</b> <b>AOLV</b> <b>OLV/PM</b> <b>AOLV/PM</b> <b>CLV/PM</b> <b>EZOLV</b><br>Sets the hysteresis level for comparator 1 as a percentage of the full scale analog output for the monitor selected in H2-20 [Comparator 1 Monitor Selection]. | 0.0%<br>(0.0 - 10.0%) |

**Note:**

For information on the comparator function, refer to 66: *Comparator1* on page 413 and 67: *Comparator2* on page 414.

### ■ H2-24: Comparator 1 On-Delay Time

| No.<br>(Hex.)   | Name                       | Description  | Default<br>(Range)       |
|-----------------|----------------------------|--|--------------------------|
| H2-24<br>(1544) | Comparator 1 On-Delay Time | <b>V/f</b> <b>CL-V/f</b> <b>OLV</b> <b>CLV</b> <b>AOLV</b> <b>OLV/PM</b> <b>AOLV/PM</b> <b>CLV/PM</b> <b>EZOLV</b><br>Sets the on-delay time for comparator 1. | 0.0 s<br>(0.0 - 600.0 s) |

**Note:**

For information on the comparator function, refer to 66: *Comparator1* on page 413 and 67: *Comparator2* on page 414.

### ■ H2-25: Comparator 1 Off-Delay Time

| No.<br>(Hex.)   | Name                        | Description   | Default<br>(Range)       |
|-----------------|-----------------------------|---|--------------------------|
| H2-25<br>(1545) | Comparator 1 Off-Delay Time | <b>V/f</b> <b>CL-V/f</b> <b>OLV</b> <b>CLV</b> <b>AOLV</b> <b>OLV/PM</b> <b>AOLV/PM</b> <b>CLV/PM</b> <b>EZOLV</b><br>Sets the off-delay time for comparator 1. | 0.0 s<br>(0.0 - 600.0 s) |

**Note:**

For information on the comparator function, refer to 66: *Comparator1* on page 413 and 67: *Comparator2* on page 414.

### ■ H2-26: Comparator 2 Monitor Selection

| No.<br>(Hex.)   | Name                           | Description   | Default<br>(Range) |
|-----------------|--------------------------------|---|--------------------|
| H2-26<br>(1546) | Comparator 2 Monitor Selection | <b>V/f</b> <b>CL-V/f</b> <b>OLV</b> <b>CLV</b> <b>AOLV</b> <b>OLV/PM</b> <b>AOLV/PM</b> <b>CLV/PM</b> <b>EZOLV</b><br>Sets the monitor number for comparator 2. Set the x-xx part of the Ux-xx [Monitor]. For example, set H2-26 = 103 to monitor U1-03 [Output Current]. | 103<br>(000 - 999) |

**Note:**

- The configurable monitor changes when the control method changes.
- When you use the terminal in through mode, set this parameter to 000 or 031. You can set the terminal output level from the PLC through MEMOBUS/Modbus communications or the communication option.
- For information on the comparator function, refer to 66: *Comparator1* on page 413 and 67: *Comparator2* on page 414.

## 2.8 H: Terminal Functions

### ■ H2-27: Comparator 2 Lower Limit

| No.<br>(Hex.)   | Name                     | Description   | Default<br>(Range)     |
|-----------------|--------------------------|---|------------------------|
| H2-27<br>(1547) | Comparator 2 Lower Limit | <div style="display: flex; gap: 5px;"> <span>V/f</span> <span>CL-V/f</span> <span>OLV</span> <span>CLV</span> <span>AOLV</span> <span>OLV/PM</span> <span>AOLV/PM</span> <span>CLV/PM</span> <span>EZOLV</span> </div> <p>Sets the lower limit detection level for comparator 2 as a percentage of the full scale analog output for the monitor selected in H2-26 [Comparator 2 Monitor Selection].</p> | 0.0%<br>(0.0 - 300.0%) |

**Note:**

For information on the comparator function, refer to 66: *Comparator1* on page 413 and 67: *Comparator2* on page 414.

### ■ H2-28: Comparator 2 Upper Limit

| No.<br>(Hex.)   | Name                     | Description   | Default<br>(Range)     |
|-----------------|--------------------------|---|------------------------|
| H2-28<br>(1548) | Comparator 2 Upper Limit | <div style="display: flex; gap: 5px;"> <span>V/f</span> <span>CL-V/f</span> <span>OLV</span> <span>CLV</span> <span>AOLV</span> <span>OLV/PM</span> <span>AOLV/PM</span> <span>CLV/PM</span> <span>EZOLV</span> </div> <p>Sets the upper limit detection level for comparator 2 as a percentage of the full scale analog output for the monitor selected in H2-26 [Comparator 2 Monitor Selection].</p> | 0.0%<br>(0.0 - 300.0%) |

**Note:**

For information on the comparator function, refer to 66: *Comparator1* on page 413 and 67: *Comparator2* on page 414.

### ■ H2-29: Comparator 2 Hysteresis

| No.<br>(Hex.)   | Name                    | Description  | Default<br>(Range)    |
|-----------------|-------------------------|--|-----------------------|
| H2-29<br>(1549) | Comparator 2 Hysteresis | <div style="display: flex; gap: 5px;"> <span>V/f</span> <span>CL-V/f</span> <span>OLV</span> <span>CLV</span> <span>AOLV</span> <span>OLV/PM</span> <span>AOLV/PM</span> <span>CLV/PM</span> <span>EZOLV</span> </div> <p>Sets the hysteresis level for comparator 2 as a percentage of the full scale analog output for the monitor selected in H2-26 [Comparator 2 Monitor Selection].</p> | 0.0%<br>(0.0 - 10.0%) |

**Note:**

For information on the comparator function, refer to 66: *Comparator1* on page 413 and 67: *Comparator2* on page 414.

### ■ H2-30: Comparator 2 On-Delay Time

| No.<br>(Hex.)   | Name                       | Description  | Default<br>(Range)       |
|-----------------|----------------------------|--|--------------------------|
| H2-30<br>(154A) | Comparator 2 On-Delay Time | <div style="display: flex; gap: 5px;"> <span>V/f</span> <span>CL-V/f</span> <span>OLV</span> <span>CLV</span> <span>AOLV</span> <span>OLV/PM</span> <span>AOLV/PM</span> <span>CLV/PM</span> <span>EZOLV</span> </div> <p>Sets the on-delay time for comparator 2.</p> | 0.0 s<br>(0.0 - 600.0 s) |

**Note:**

For information on the comparator function, refer to 66: *Comparator1* on page 413 and 67: *Comparator2* on page 414.

### ■ H2-31: Comparator 2 Off-Delay Time

| No.<br>(Hex.)   | Name                        | Description   | Default<br>(Range)       |
|-----------------|-----------------------------|---|--------------------------|
| H2-31<br>(154B) | Comparator 2 Off-Delay Time | <div style="display: flex; gap: 5px;"> <span>V/f</span> <span>CL-V/f</span> <span>OLV</span> <span>CLV</span> <span>AOLV</span> <span>OLV/PM</span> <span>AOLV/PM</span> <span>CLV/PM</span> <span>EZOLV</span> </div> <p>Sets the off-delay time for comparator 2.</p> | 0.0 s<br>(0.0 - 600.0 s) |

**Note:**

For information on the comparator function, refer to 66: *Comparator1* on page 413 and 67: *Comparator2* on page 414.

### ■ H2-32: Comparator 1 Filter Time

| No.<br>(Hex.)   | Name                     | Description  | Default<br>(Range)     |
|-----------------|--------------------------|--|------------------------|
| H2-32<br>(159A) | Comparator 1 Filter Time | <div style="display: flex; gap: 5px;"> <span>V/f</span> <span>CL-V/f</span> <span>OLV</span> <span>CLV</span> <span>AOLV</span> <span>OLV/PM</span> <span>AOLV/PM</span> <span>CLV/PM</span> <span>EZOLV</span> </div> <p>Sets the time constant that is applied to the primary delay filter used for the analog output of the monitor selected with H2-20 [Comparator 1 Monitor Selection].</p> | 0.0s<br>(0.0 - 10.0 s) |

**Note:**

For information on the comparator function, refer to 66: *Comparator1* on page 413 and 67: *Comparator2* on page 414.



### ■ H2-33: Comparator1 Protection Selection

| No. (Hex.)   | Name                             | Description   | Default (Range) |
|--------------|----------------------------------|---|-----------------|
| H2-33 (159B) | Comparator1 Protection Selection | <div style="display: flex; gap: 5px;"> <span>V/f</span> <span>CL-V/f</span> <span>OLV</span> <span>CLV</span> <span>AOLV</span> <span>OLV/PM</span> <span>AOLV/PM</span> <span>CLV/PM</span> <span>EZOLV</span> </div> Sets drive operation when it detects <i>CP1</i> [Comparator1 Limit Fault]. | 4<br>(0 - 4)    |

#### 0 : Ramp to Stop

The drive ramps the motor to stop in the deceleration time. Fault relay output terminal MA-MC turns ON, and MB-MC turns OFF.

#### 1 : Coast to Stop

The output turns off and the motor coasts to stop. Fault relay output terminal MA-MC turns ON, and MB-MC turns OFF.

#### 2 : Fast Stop

The drive stops the motor in the deceleration time set in *C1-09* [Fast Stop Time]. Fault relay output terminal MA-MC turns ON, and MB-MC turns OFF.

#### 3 : Alarm Only

The keypad shows *CP1* and the drive continues operation at the current frequency reference.

##### Note:

The output terminal set for *Alarm* [H2-01 to H2-03 = 10] turns ON.

#### 4 : Digital Output Only

### ■ H2-34: Comparator 2 Filter Time

| No. (Hex.)   | Name                     | Description  | Default (Range)        |
|--------------|--------------------------|--|------------------------|
| H2-34 (159C) | Comparator 2 Filter Time | <div style="display: flex; gap: 5px;"> <span>V/f</span> <span>CL-V/f</span> <span>OLV</span> <span>CLV</span> <span>AOLV</span> <span>OLV/PM</span> <span>AOLV/PM</span> <span>CLV/PM</span> <span>EZOLV</span> </div> Sets the time constant that is applied to the primary delay filter used for the analog output of the monitor selected with <i>H2-26</i> [Comparator 2 Monitor Selection]. | 0.0s<br>(0.0 - 10.0 s) |

### ■ H2-35: Comparator2 Protection Selection

| No. (Hex.)   | Name                             | Description   | Default (Range) |
|--------------|----------------------------------|---|-----------------|
| H2-35 (159D) | Comparator2 Protection Selection | <div style="display: flex; gap: 5px;"> <span>V/f</span> <span>CL-V/f</span> <span>OLV</span> <span>CLV</span> <span>AOLV</span> <span>OLV/PM</span> <span>AOLV/PM</span> <span>CLV/PM</span> <span>EZOLV</span> </div> Sets drive operation when it detects <i>CP2</i> [Comparator2 Limit Fault]. | 4<br>(0 - 4)    |

#### 0 : Ramp to Stop

The drive ramps the motor to stop in the deceleration time. Fault relay output terminal MA-MC turns ON, and MB-MC turns OFF.

#### 1 : Coast to Stop

The output turns off and the motor coasts to stop. Fault relay output terminal MA-MC turns ON, and MB-MC turns OFF.

#### 2 : Fast Stop

The drive stops the motor in the deceleration time set in *C1-09* [Fast Stop Time]. Fault relay output terminal MA-MC turns ON, and MB-MC turns OFF.

#### 3 : Alarm Only

The keypad shows *CP2* and the drive continues operation at the current frequency reference.

##### Note:

The output terminal set for *Alarm* [H2-01 to H2-03 = 10] turns ON.

#### 4 : Digital Output Only

## 2.8 H: Terminal Functions

### ■ H2-36: Comparator 1 Ineffective Time

| No. (Hex.)   | Name                          | Description  | Default (Range)           |
|--------------|-------------------------------|--|---------------------------|
| H2-36 (159E) | Comparator 1 Ineffective Time | <b>V/f</b> <b>CL-V/f</b> <b>OLV</b> <b>CLV</b> <b>AOLV</b> <b>OLV/PM</b> <b>AOLV/PM</b> <b>CLV/PM</b> <b>EZOLV</b><br>Sets the length of time that <i>CP1</i> [Comparator1 Limit Fault] is disabled. | 0.0 s<br>(0.0 - 1000.0 s) |

**Note:**

- After you enter a Run command and wait for the time set in this parameter, the drive will monitor operation and make sure that it is in the Comparator 1 range until you enter the Stop command.
- When *CP1* detection is disabled, the drive will turn on the output terminal set for *Comparator 1* [H2-xx = 66].

### ■ H2-37: Comparator 2 Ineffective Time

| No. (Hex.)   | Name                          | Description  | Default (Range)           |
|--------------|-------------------------------|--|---------------------------|
| H2-37 (159F) | Comparator 2 Ineffective Time | <b>V/f</b> <b>CL-V/f</b> <b>OLV</b> <b>CLV</b> <b>AOLV</b> <b>OLV/PM</b> <b>AOLV/PM</b> <b>CLV/PM</b> <b>EZOLV</b><br>Sets the length of time that <i>CP2</i> [Comparator2 Limit Fault] is disabled. | 0.0 s<br>(0.0 - 1000.0 s) |

**Note:**

- After you enter a Run command and wait for the time set in this parameter, the drive will monitor operation and make sure that it is in the Comparator 2 range until you enter the Stop command.
- When *CP2* detection is disabled, the drive will turn on the output terminal set for *Comparator 2* [H2-xx = 67].

### ■ H2-40: Mbus Reg 15E0h bit0 Output Func

| No. (Hex.)   | Name                            | Description  | Default (Range) |
|--------------|---------------------------------|--|-----------------|
| H2-40 (0B58) | Mbus Reg 15E0h bit0 Output Func | <b>V/f</b> <b>CL-V/f</b> <b>OLV</b> <b>CLV</b> <b>AOLV</b> <b>OLV/PM</b> <b>AOLV/PM</b> <b>CLV/PM</b> <b>EZOLV</b><br>Sets the MFDO for bit 0 of MEMOBUS register 15E0 (Hex.). | F<br>(0 - 1FF)  |

### ■ H2-41: Mbus Reg 15E0h bit1 Output Func

| No. (Hex.)   | Name                            | Description  | Default (Range) |
|--------------|---------------------------------|--|-----------------|
| H2-41 (0B59) | Mbus Reg 15E0h bit1 Output Func | <b>V/f</b> <b>CL-V/f</b> <b>OLV</b> <b>CLV</b> <b>AOLV</b> <b>OLV/PM</b> <b>AOLV/PM</b> <b>CLV/PM</b> <b>EZOLV</b><br>Sets the MFDO for bit 1 of MEMOBUS register 15E0 (Hex.). | F<br>(0 - 1FF)  |

### ■ H2-42: Mbus Reg 15E0h bit2 Output Func

| No. (Hex.)   | Name                            | Description  | Default (Range) |
|--------------|---------------------------------|--|-----------------|
| H2-42 (0B5A) | Mbus Reg 15E0h bit2 Output Func | <b>V/f</b> <b>CL-V/f</b> <b>OLV</b> <b>CLV</b> <b>AOLV</b> <b>OLV/PM</b> <b>AOLV/PM</b> <b>CLV/PM</b> <b>EZOLV</b><br>Sets the MFDO for bit 2 of MEMOBUS register 15E0 (Hex.). | F<br>(0 - 1FF)  |

### ■ H2-60: Selects the second function for terminal M1-M2.

| No. (Hex.)          | Name                          | Description  | Default (Range) |
|---------------------|-------------------------------|--|-----------------|
| H2-60 (1B46) Expert | Term M1-M2 Secondary Function | <b>V/f</b> <b>CL-V/f</b> <b>OLV</b> <b>CLV</b> <b>AOLV</b> <b>OLV/PM</b> <b>AOLV/PM</b> <b>CLV/PM</b> <b>EZOLV</b><br>Sets the second function for terminal M1-M2. The logical calculation results of the terminals assigned to functions by <i>H2-01</i> [Term M1-M2 Function Selection] is output. | F<br>(0 - FF)   |

### ■ H2-61: Terminal M1-M2 Logical Operation

| No. (Hex.)          | Name                             | Description  | Default (Range) |
|---------------------|----------------------------------|--|-----------------|
| H2-61 (1B47) Expert | Terminal M1-M2 Logical Operation | <b>V/f</b> <b>CL-V/f</b> <b>OLV</b> <b>CLV</b> <b>AOLV</b> <b>OLV/PM</b> <b>AOLV/PM</b> <b>CLV/PM</b> <b>EZOLV</b><br>Sets the logical operation for the functions set in <i>H2-01</i> [Term M1-M2 Function Selection] and <i>H2-60</i> [Term M1-M2 Secondary Function]. | 0<br>(0 - 8)    |

**Note:**

Refer to *Output of Logical Operation Results of MFDO on page 392* for more information about the relation between parameter settings and logical operations.

### ■ H2-62: Terminal M1-M2 Delay Time

| No. (Hex.)             | Name                      | Description  | Default (Range)         |
|------------------------|---------------------------|--|-------------------------|
| H2-62 (1B48)<br>Expert | Terminal M1-M2 Delay Time | <b>V/f</b> <b>CL-V/f</b> <b>OLV</b> <b>CLV</b> <b>AOLV</b> <b>OLV/PM</b> <b>AOLV/PM</b> <b>CLV/PM</b> <b>EZOLV</b><br>Sets the minimum on time used to output the logical calculation results from terminal M1-M2. | 0.1 s<br>(0.0 - 25.0 s) |

### ■ H2-63: Term M3-M4 Secondary Function

| No. (Hex.)             | Name                          | Description   | Default (Range) |
|------------------------|-------------------------------|---|-----------------|
| H2-63 (1B49)<br>Expert | Term M3-M4 Secondary Function | <b>V/f</b> <b>CL-V/f</b> <b>OLV</b> <b>CLV</b> <b>AOLV</b> <b>OLV/PM</b> <b>AOLV/PM</b> <b>CLV/PM</b> <b>EZOLV</b><br>Sets the second function for terminal M3-M4. The logical calculation results of the terminals assigned to functions by H2-02 [Term M3-M4 Function Selection] is output. | F<br>(0 - FF)   |

### ■ H2-64: Terminal M3-M4 Logical Operation

| No. (Hex.)             | Name                             | Description  | Default (Range) |
|------------------------|----------------------------------|--|-----------------|
| H2-64 (1B4A)<br>Expert | Terminal M3-M4 Logical Operation | <b>V/f</b> <b>CL-V/f</b> <b>OLV</b> <b>CLV</b> <b>AOLV</b> <b>OLV/PM</b> <b>AOLV/PM</b> <b>CLV/PM</b> <b>EZOLV</b><br>Sets the logical operation for the functions set in H2-02 [Term M3-M4 Function Selection] and H2-63 [Term M3-M4 Secondary Function]. | 0<br>(0 - 8)    |

**Note:**

Refer to *Output of Logical Operation Results of MFDO on page 392* for more information about the relation between parameter settings and logical operations.

### ■ H2-65: Terminal M3-M4 Delay Time

| No. (Hex.)             | Name                        | Description  | Default (Range)         |
|------------------------|-----------------------------|--|-------------------------|
| H2-65 (1B4B)<br>Expert | Digital Output 2 Delay Time | <b>V/f</b> <b>CL-V/f</b> <b>OLV</b> <b>CLV</b> <b>AOLV</b> <b>OLV/PM</b> <b>AOLV/PM</b> <b>CLV/PM</b> <b>EZOLV</b><br>Sets the minimum on time used to output the logical calculation results from terminal M3-M4. | 0.1 s<br>(0.0 - 25.0 s) |

### ■ H2-66: Term M5-M6 Secondary Function

| No. (Hex.)             | Name                          | Description  | Default (Range) |
|------------------------|-------------------------------|--|-----------------|
| H2-66 (1B4C)<br>Expert | Term M5-M6 Secondary Function | <b>V/f</b> <b>CL-V/f</b> <b>OLV</b> <b>CLV</b> <b>AOLV</b> <b>OLV/PM</b> <b>AOLV/PM</b> <b>CLV/PM</b> <b>EZOLV</b><br>Sets the second function for terminal M5-M6. The logical calculation results of the terminals assigned to functions by H2-03 [Terminal M5-M6 Function Select] is output. | F<br>(0 - FF)   |

### ■ H2-67: Terminal M5-M6 Logical Operation

| No. (Hex.)             | Name                             | Description  | Default (Range) |
|------------------------|----------------------------------|--|-----------------|
| H2-67 (1B4D)<br>Expert | Terminal M5-M6 Logical Operation | <b>V/f</b> <b>CL-V/f</b> <b>OLV</b> <b>CLV</b> <b>AOLV</b> <b>OLV/PM</b> <b>AOLV/PM</b> <b>CLV/PM</b> <b>EZOLV</b><br>Sets the logical operation for the functions set in H2-03 [Term M5-M6 Function Selection] and H2-66 [Term M5-M6 Secondary Function]. | 0<br>(0 - 8)    |

**Note:**

Refer to *Output of Logical Operation Results of MFDO on page 392* for more information about the relation between parameter settings and logical operations.

### ■ H2-68: Terminal M5-M6 Delay Time

| No. (Hex.)             | Name                        | Description  | Default (Range)         |
|------------------------|-----------------------------|--|-------------------------|
| H2-68 (1B4E)<br>Expert | Digital Output 3 Delay Time | <b>V/f</b> <b>CL-V/f</b> <b>OLV</b> <b>CLV</b> <b>AOLV</b> <b>OLV/PM</b> <b>AOLV/PM</b> <b>CLV/PM</b> <b>EZOLV</b><br>Sets the minimum on time used to output the logical calculation results from terminal M5-M6. | 0.1 s<br>(0.0 - 25.0 s) |

### ◆ MFDO Setting Value

Selects the function configured to MFDO.

#### ■ 0: During Run

| Setting Value | Function   | Description   |
|---------------|------------|---|
| 0             | During Run | <div style="display: flex; justify-content: space-between; align-items: center;"> <span>V/f</span> <span>CL-V/f</span> <span>OLV</span> <span>CLV</span> <span>AOLV</span> <span>OLV/PM</span> <span>AOLV/PM</span> <span>CLV/PM</span> <span>EZOLV</span> </div> <p>The terminal activates when the Run command is input and when the drive is outputting a voltage.</p> |

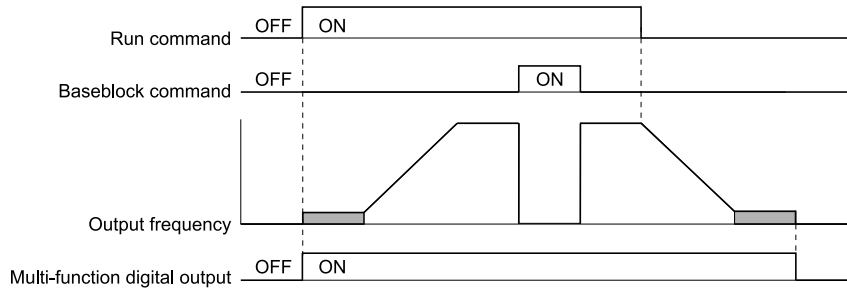


Figure 2.89 Drive Running Time Chart

#### ON : Drive is running

The drive is receiving a Run command or outputting a voltage.

#### OFF : Drive is stopping

Drive is stopped.

#### ■ 1: Zero Speed

| Setting Value | Function   | Description   |
|---------------|------------|---|
| 1             | Zero Speed | <div style="display: flex; justify-content: space-between; align-items: center;"> <span>V/f</span> <span>CL-V/f</span> <span>OLV</span> <span>CLV</span> <span>AOLV</span> <span>OLV/PM</span> <span>AOLV/PM</span> <span>CLV/PM</span> <span>EZOLV</span> </div> <p>The terminal activates when the output frequency is less than the value of E1-09 [Minimum Output Frequency] or b2-01 [DC Injection/Zero SpeedThreshold].</p> |

**Note:**

Parameter A1-02 [Control Method Selection] selects which parameter is the reference.

| A1-02 Setting | Control method selection         | Parameter Used as the Reference |
|---------------|----------------------------------|---------------------------------|
| 0             | V/f Control                      | E1-09                           |
| 1             | V/f Control with Encoder         | E1-09                           |
| 2             | Open Loop Vector                 | b2-01                           |
| 3             | Closed Loop Vector               | E1-09                           |
| 4             | Advanced OpenLoop Vector Control | E1-09                           |
| 5             | PM Open Loop Vector Control      | E1-09                           |
| 6             | PM Advanced Open Loop Vector     | E1-09                           |
| 7             | PM Closed Loop Vector Control    | b2-01                           |
| 8             | EZ Open Loop Vector Control      | E1-09                           |

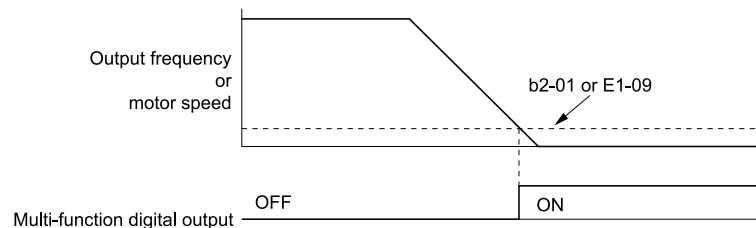


Figure 2.90 Zero Speed Time Chart

**ON** : Output frequency < value of *E1-09* or *b2-01*.

**OFF** : Output frequency  $\geq$  value of *E1-09* or *b2-01*.

### ■ 2: Speed Agree 1

| Setting Value | Function      | Description   |
|---------------|---------------|---|
| 2             | Speed Agree 1 | <b>V/f</b> <b>CL-V/f</b> <b>OLV</b> <b>CLV</b> <b>AOLV</b> <b>OLV/PM</b> <b>AOLV/PM</b> <b>CLV/PM</b> <b>EZOLV</b><br>The terminal turns on when the output frequency is in the range of the frequency reference $\pm L4-02$ [Speed Agree Detection Width]. |

**Note:**

- The detection function operates in the two motor rotation directions.
- The drive outputs the motor speed status if *A1-02* = 3, 7 [CLV, CLV/PM]. It outputs the motor speed status also if *A1-02* = 4 and *n4-72* = 1.

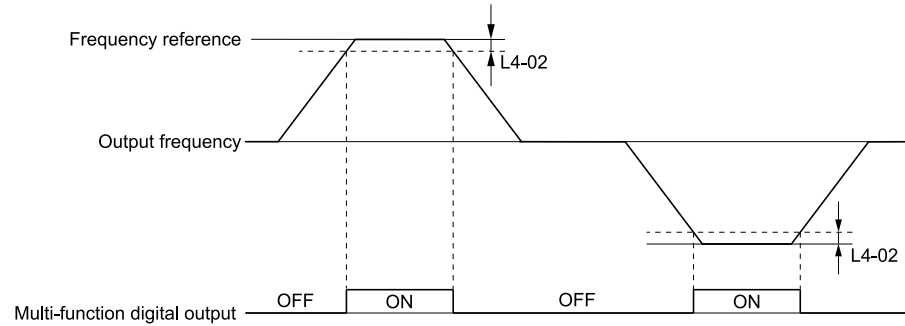


Figure 2.91 Speed Agree 1 Time Chart

**ON** : The output frequency is in the range of “frequency reference  $\pm L4-02$ ”.

**OFF** : The output frequency does not align with the frequency reference although the drive is running.

### ■ 3: User-Set Speed Agree 1

| Setting Value | Function               | Description  |
|---------------|------------------------|--|
| 3             | User-Set Speed Agree 1 | <b>V/f</b> <b>CL-V/f</b> <b>OLV</b> <b>CLV</b> <b>AOLV</b> <b>OLV/PM</b> <b>AOLV/PM</b> <b>CLV/PM</b> <b>EZOLV</b><br>The terminal activates when the output frequency is in the range of <i>L4-01</i> [Speed Agree Detection Level] $\pm L4-02$ [Speed Agree Detection Width] and in the range of the frequency reference $\pm L4-02$ . |

**Note:**

- The detection function operates in the two motor rotation directions. The drive uses the *L4-01* value as the forward/reverse detection level.
- The drive outputs the motor speed status if *A1-02* = 3, 7 [CLV, CLV/PM]. It outputs the motor speed status also if *A1-02* = 4 and *n4-72* = 1.

**ON** : The output frequency is in the range of “*L4-01*  $\pm L4-02$ ” and the range of frequency reference  $\pm L4-02$ .

**OFF** : The output frequency is not in the range of “*L4-01*  $\pm L4-02$ ” or the range of frequency reference  $\pm L4-02$ .

## 2.8 H: Terminal Functions

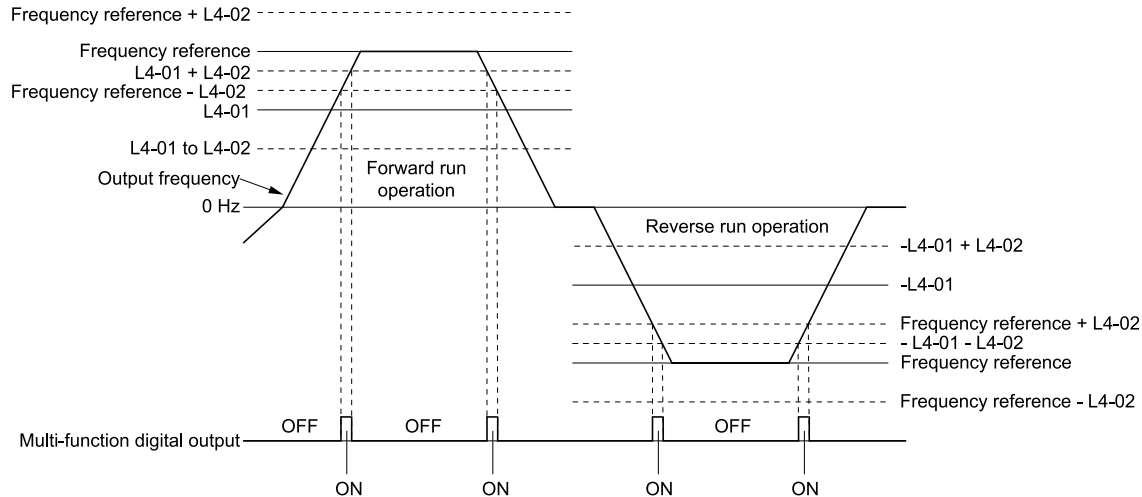


Figure 2.92 User-Defined Speed Agree 1 Time Chart

### 4: Frequency Detection 1

| Setting Value | Function              | Description   |
|---------------|-----------------------|---|
| 4             | Frequency Detection 1 | <p><b>V/f</b> <b>CL-V/f</b> <b>OLV</b> <b>CLV</b> <b>AOLV</b> <b>OLV/PM</b> <b>AOLV/PM</b> <b>CLV/PM</b> <b>EZOLV</b></p> <p>The terminal deactivates when the output frequency is higher than the value of <math>L4-01</math> [Speed Agree Detection Level] + <math>L4-02</math> [Speed Agree Detection Width]. After the terminal turns off, the terminal continues to remain off until the output frequency reaches the level set with <math>L4-01</math>.</p> |

**Note:**

- The detection function operates in the two motor rotation directions. The drive uses the  $L4-01$  value as the forward/reverse detection level.
- The drive outputs the motor speed status if  $A1-02 = 3, 7$  [CLV, CLV/PM]. It outputs the motor speed status also if  $A1-02 = 4$  and  $n4-72 = 1$ .

**ON :** The output frequency is less than the value of  $L4-01$  or does not exceed the value of  $L4-01 + L4-02$ .

**OFF :** The output frequency is higher than the value of  $L4-01 + L4-02$ .

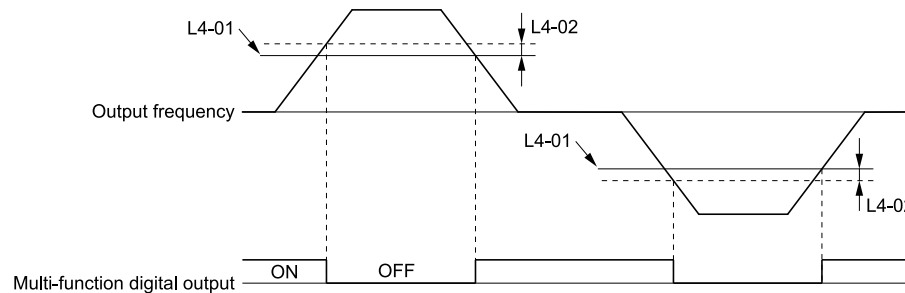


Figure 2.93 Frequency Detection 1 Time Chart

**Note:**

Figure 2.93 shows the result of the configuration when  $L4-07 = 1$  [Speed Agree Detection Selection = Detection Always Enabled]. The default setting of  $L4-07$  is 0 [No detection during baseblock]. When the speed agreement detection selection is “No Detection during Baseblock”, the terminal is deactivated when the drive output stops.

### 5: Frequency Detection 2

| Setting Value | Function              | Description   |
|---------------|-----------------------|---|
| 5             | Frequency Detection 2 | <p><b>V/f</b> <b>CL-V/f</b> <b>OLV</b> <b>CLV</b> <b>AOLV</b> <b>OLV/PM</b> <b>AOLV/PM</b> <b>CLV/PM</b> <b>EZOLV</b></p> <p>The terminal activates when the output frequency is higher than the value of <math>L4-01</math> [Speed Agree Detection Level]. After the terminal activates, the terminal stays on until the output frequency is at the value of <math>L4-01 - L4-02</math>.</p> |

**Note:**

- The detection function operates in the two motor rotation directions. The drive uses the  $L4-01$  value as the forward/reverse detection level.
- The drive outputs the motor speed status if  $A1-02 = 3, 7$  [CLV, CLV/PM]. It outputs the motor speed status also if  $A1-02 = 4$  and  $n4-72 = 1$ .

**ON :** The output frequency is higher than the value of  $L4-01$ .

**OFF** : The output frequency is less than the value of “L4-01 - L4-02”, or it is not higher than the value of L4-01.

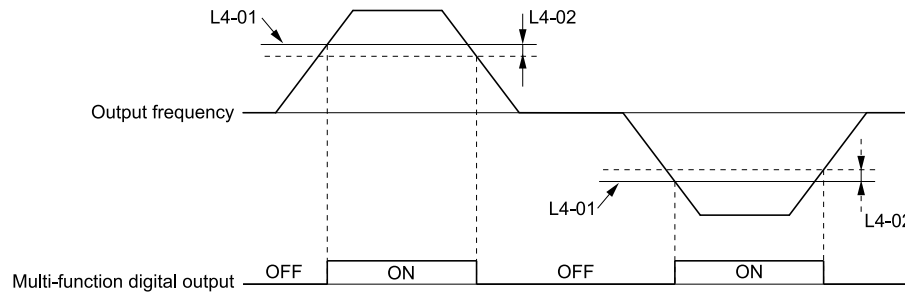


Figure 2.94 Frequency Detection 2 Time Chart

■ 6: Drive ready

| Setting Value | Function    | Description   |
|---------------|-------------|---|
| 6             | Drive ready | <b>V/f</b> <b>CL-V/f</b> <b>OLV</b> <b>CLV</b> <b>AOLV</b> <b>OLV/PM</b> <b>AOLV/PM</b> <b>CLV/PM</b> <b>EZOLV</b><br>The terminal activates when the drive is ready and running. |

The terminal deactivates in these conditions:

- When the power supply is OFF
- During a fault
- When there is problem with the control power supply
- When there is a parameter configuration error and the drive cannot operate although there is a Run command
- When you enter a Run command and it immediately triggers an overvoltage or undervoltage fault because the drive has an overvoltage or undervoltage fault during stop
- When the drive is in Programming Mode and will not accept a Run command

■ 7: DC Bus Undervoltage

| Setting Value | Function            | Description  |
|---------------|---------------------|--|
| 7             | DC Bus Undervoltage | <b>V/f</b> <b>CL-V/f</b> <b>OLV</b> <b>CLV</b> <b>AOLV</b> <b>OLV/PM</b> <b>AOLV/PM</b> <b>CLV/PM</b> <b>EZOLV</b><br>The terminal activates when the DC bus voltage or control circuit power supply is less than the voltage set with L2-05 [Undervoltage Detection Lvl (UvL)]. The terminal also turns on when there is a fault with the DC bus voltage. |

**ON** : The DC bus voltage is less than the setting value of L2-05.

**OFF** : The DC bus voltage is more than the setting value of L2-05.

■ 8: During Baseblock (N.O.)

| Setting Value | Function                | Description   |
|---------------|-------------------------|---|
| 8             | During Baseblock (N.O.) | <b>V/f</b> <b>CL-V/f</b> <b>OLV</b> <b>CLV</b> <b>AOLV</b> <b>OLV/PM</b> <b>AOLV/PM</b> <b>CLV/PM</b> <b>EZOLV</b><br>The terminal turns on during baseblock. When the drive is in baseblock, the drive output transistor stops switching and does not make DC bus voltage. |

**ON** : During baseblock

**OFF** : The drive is not in baseblock.

■ 9: Frequency Reference from Keypad

| Setting Value | Function                        | Description  |
|---------------|---------------------------------|--|
| 9             | Frequency Reference from Keypad | <b>V/f</b> <b>CL-V/f</b> <b>OLV</b> <b>CLV</b> <b>AOLV</b> <b>OLV/PM</b> <b>AOLV/PM</b> <b>CLV/PM</b> <b>EZOLV</b><br>Shows the selected frequency reference source. |

**ON** : The keypad is the frequency reference source.

**OFF** : b1-01 or b1-15 [Frequency Reference Selection 1 or 2] is the frequency reference source.

## 2.8 H: Terminal Functions

### ■ A: Run Command from Keypad

| Setting Value | Function           | Description  |
|---------------|--------------------|--|
| A             | Run Command Source | <div style="display: flex; justify-content: space-between; gap: 5px;"> <span>V/f</span> <span>CL-V/f</span> <span>OLV</span> <span>CLV</span> <span>AOLV</span> <span>OLV/PM</span> <span>AOLV/PM</span> <span>CLV/PM</span> <span>EZOLV</span> </div> <p>Shows the selected Run command source.</p> |

**ON :** The keypad is the Run command source.

**OFF :** *b1-02* or *b1-16* [Run Command Selection 1 or 2] is the Run command source.

### ■ B: Torque Detection 1 (N.O.)

| Setting Value | Function                  | Description  |
|---------------|---------------------------|--|
| B             | Torque Detection 1 (N.O.) | <div style="display: flex; justify-content: space-between; gap: 5px;"> <span>V/f</span> <span>CL-V/f</span> <span>OLV</span> <span>CLV</span> <span>AOLV</span> <span>OLV/PM</span> <span>AOLV/PM</span> <span>CLV/PM</span> <span>EZOLV</span> </div> <p>The terminal activates when the drive detects overtorque or undertorque.</p> |

**ON :** The output current/torque is more than the torque value set with *L6-02* [Torque Detection Level 1], or the level is less than the torque value set with *L6-02* for longer than the time set with *L6-03* [Torque Detection Time 1].

**Note:**

- When  $L6-01 \geq 5$ , the drive will detect when the output current/torque is less than the detection level of *L6-02* for longer than the time set in *L6-03*.

- Refer to “L6: Torque Detection” for more information.

### ■ C: Frequency Reference Loss

| Setting Value | Function                 | Description  |
|---------------|--------------------------|--|
| C             | Frequency Reference Loss | <div style="display: flex; justify-content: space-between; gap: 5px;"> <span>V/f</span> <span>CL-V/f</span> <span>OLV</span> <span>CLV</span> <span>AOLV</span> <span>OLV/PM</span> <span>AOLV/PM</span> <span>CLV/PM</span> <span>EZOLV</span> </div> <p>The terminal activates when the drive detects a loss of frequency reference.</p> |

**Note:**

Refer to “L4-05: Fref Loss Detection Selection” for more information.

### ■ D: Braking Resistor Fault

| Setting Value | Function               | Description  |
|---------------|------------------------|--|
| D             | Braking Resistor Fault | <div style="display: flex; justify-content: space-between; gap: 5px;"> <span>V/f</span> <span>CL-V/f</span> <span>OLV</span> <span>CLV</span> <span>AOLV</span> <span>OLV/PM</span> <span>AOLV/PM</span> <span>CLV/PM</span> <span>EZOLV</span> </div> <p>The terminal activates when the mounting-type braking resistor is overheating or when there is a braking transistor fault.</p> |

### ■ E: Faults

| Setting Value | Function | Description  |
|---------------|----------|--|
| E             | Faults   | <div style="display: flex; justify-content: space-between; gap: 5px;"> <span>V/f</span> <span>CL-V/f</span> <span>OLV</span> <span>CLV</span> <span>AOLV</span> <span>OLV/PM</span> <span>AOLV/PM</span> <span>CLV/PM</span> <span>EZOLV</span> </div> <p>The terminal activates when the drive detects a fault.</p> |

**Note:**

The terminal will not turn on for *CPF00* and *CPF01* [Control Circuit Error] faults.

### ■ F: Not Used

| Setting Value | Function | Description  |
|---------------|----------|--|
| F             | Not Used | <div style="display: flex; justify-content: space-between; gap: 5px;"> <span>V/f</span> <span>CL-V/f</span> <span>OLV</span> <span>CLV</span> <span>AOLV</span> <span>OLV/PM</span> <span>AOLV/PM</span> <span>CLV/PM</span> <span>EZOLV</span> </div> <p>Use this setting for unused terminals or to use terminals in through mode. Also use this setting as the PLC contact output via MEMOBUS/Modbus or the communication option. This signal does not function if signals from the PLC are not configured.</p> |

### ■ 10: Alarm

| Setting Value | Function | Description   |
|---------------|----------|---|
| 10            | Alarm    | <div style="display: flex; justify-content: space-between; gap: 5px;"> <span>V/f</span> <span>CL-V/f</span> <span>OLV</span> <span>CLV</span> <span>AOLV</span> <span>OLV/PM</span> <span>AOLV/PM</span> <span>CLV/PM</span> <span>EZOLV</span> </div> <p>The terminal turns on when the drive detects a minor fault.</p> |



■ 11: Fault Reset Command Active

| Setting Value | Function                   | Description  |
|---------------|----------------------------|--|
| 11            | Fault Reset Command Active | <p>V/f CL-V/f OLV CLV AOLV OLV/PM AOLV/PM CLV/PM EZOLV</p> <p>The terminal turns on when the drive receives the Reset command from the control circuit terminal, serial communications, or the communication option.</p> |

■ 12: Timer Output

| Setting Value | Function     | Description  |
|---------------|--------------|--|
| 12            | Timer Output | <p>V/f CL-V/f OLV CLV AOLV OLV/PM AOLV/PM CLV/PM EZOLV</p> <p>Use this setting when the drive uses the timer function as an output terminal.</p> |

**Note:**

Refer to “b4: Timer Function” for more information.

■ 13: Speed Agree 2

| Setting Value | Function      | Description   |
|---------------|---------------|---|
| 13            | Speed Agree 2 | <p>V/f CL-V/f OLV CLV AOLV OLV/PM AOLV/PM CLV/PM EZOLV</p> <p>The terminal activates when the output frequency is in the range of the frequency reference <math>\pm L4-04</math> [Speed Agree Detection Width (+/-)].</p> |

**Note:**

- The detection function operates in the two motor rotation directions.
- The drive outputs the motor speed status if  $A1-02 = 3, 7$  [Control Method Selection = CLV, CLV/PM].

**ON :** The output frequency is in the range of “frequency reference  $\pm L4-04$ ”.

**OFF :** The output frequency is not in the range of “frequency reference  $\pm L4-04$ ”.

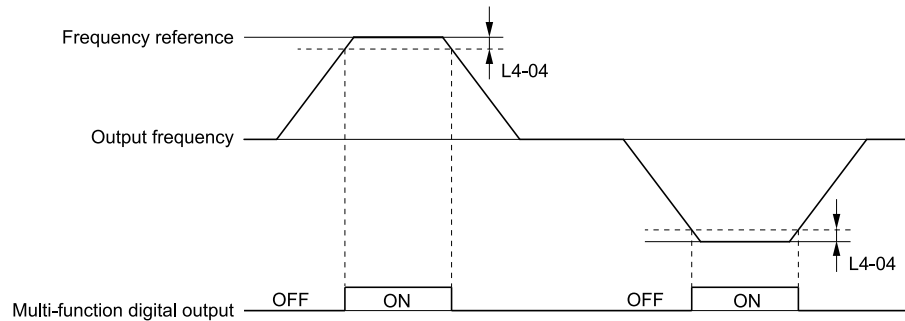


Figure 2.95 Speed Agree 2 Time Chart

■ 14: User-Set Speed Agree 2

| Setting Value | Function               | Description   |
|---------------|------------------------|---|
| 14            | User-Set Speed Agree 2 | <p>V/f CL-V/f OLV CLV AOLV OLV/PM AOLV/PM CLV/PM EZOLV</p> <p>The terminal activates when the output frequency is in the range of <math>L4-03</math> [Speed Agree Detection Level (+/-)] <math>\pm L4-04</math> [Speed Agree Detection Width (+/-)] and in the range of the frequency reference <math>\pm L4-04</math>.</p> |

**Note:**

- The detection level configured with  $L4-03$  is a signed value. The drive will only detect in one direction.
- The drive outputs the motor speed status if  $A1-02 = 3, 7$  [Control Method Selection = CLV, CLV/PM].

**ON :** The output frequency is in the range of “ $L4-03 \pm L4-04$ ” and the range of frequency reference  $\pm L4-04$ .

**OFF :** The output frequency is not in the range of “ $L4-03 \pm L4-04$ ” or the range of frequency reference  $\pm L4-04$ .

## 2.8 H: Terminal Functions

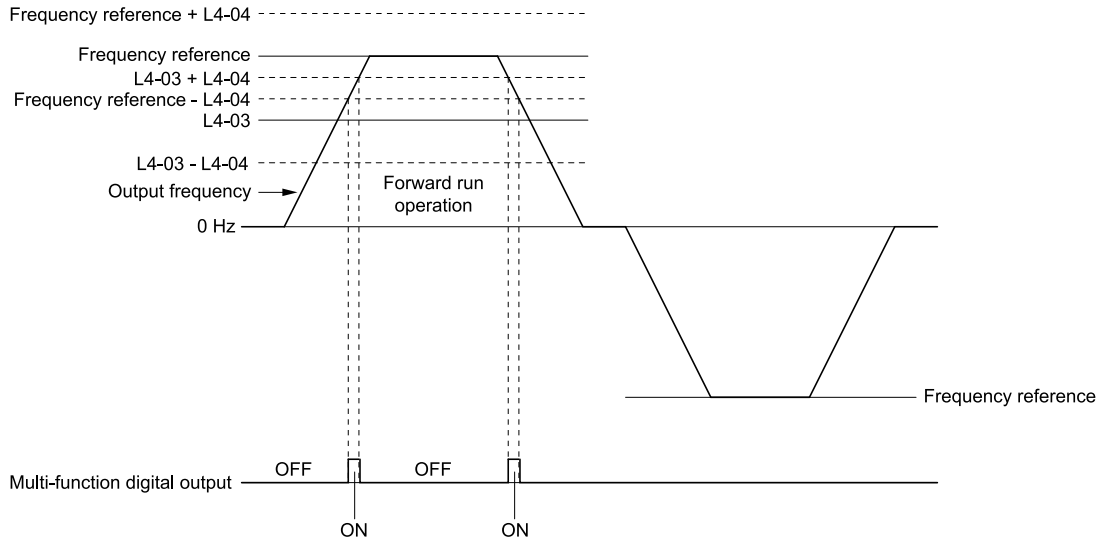


Figure 2.96 Example of User-set Speed Agree 2 (L4-03 Is Positive)

### 15: Frequency Detection 3

| Setting Value | Function              | Description   |
|---------------|-----------------------|---|
| 15            | Frequency Detection 3 | <div style="display: flex; justify-content: space-between; font-size: small;"> <span>V/f</span> <span>CL-V/f</span> <span>OLV</span> <span>CLV</span> <span>AOLV</span> <span>OLV/PM</span> <span>AOLV/PM</span> <span>CLV/PM</span> <span>EZOLV</span> </div> <p>The terminal deactivates when the output frequency is higher than the value of "L4-03 [Speed Agree Detection Level (+/-)] + L4-04 [Speed Agree Detection Width (+/-)]". After the terminal deactivates, the terminal stays off until the output frequency is at the value of L4-03.</p> |

**Note:**

- The detection level configured with L4-03 is a signed value. The drive will only detect in one direction.
- The drive outputs the motor speed status if A1-02 = 3, 7 [Control Method Selection = CLV, CLV/PM].

**ON :** The output frequency is less than the value of L4-03 or is not higher than the value of L4-03 + L4-04.

**OFF :** The output frequency is higher than the value of L4-03 + L4-04.

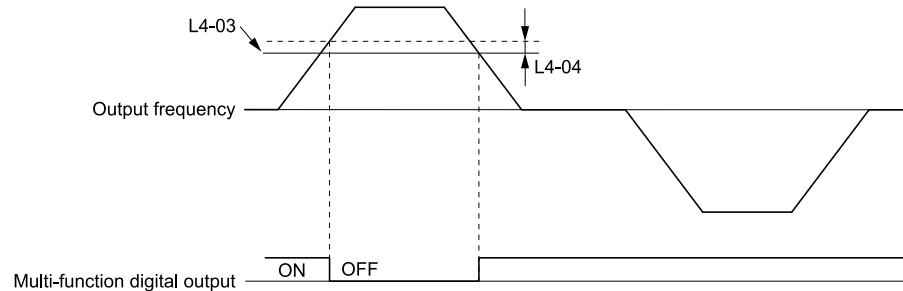


Figure 2.97 Example of Frequency Detection 3 (value of L4-03 Is Positive)

**Note:**

Figure 2.97 shows the time chart when L4-07 = 1 [Speed Agree Detection Selection = Detection Always Enabled]. The default setting of L4-07 is 0 [No detection during baseblock]. When the speed agreement detection selection is "No Detection during Baseblock", the terminal is deactivated when the drive output stops.

### 16: Frequency Detection 4

| Setting Value | Function              | Description  |
|---------------|-----------------------|--|
| 16            | Frequency Detection 4 | <div style="display: flex; justify-content: space-between; font-size: small;"> <span>V/f</span> <span>CL-V/f</span> <span>OLV</span> <span>CLV</span> <span>AOLV</span> <span>OLV/PM</span> <span>AOLV/PM</span> <span>CLV/PM</span> <span>EZOLV</span> </div> <p>The terminal activates when the output frequency is higher than the value of L4-03 [Speed Agree Detection Level (+/-)]. After the terminal activates, the terminal stays on until the output frequency is at the value of L4-03 - L4-04.</p> |

**Note:**

- The detection level configured with L4-03 is a signed value. The drive will only detect in one direction.
- The drive outputs the motor speed status if A1-02 = 3, 7 [Control Method Selection = CLV, CLV/PM].

**ON** : The output frequency is higher than the value of **L4-03**.

**OFF** : The output frequency is less than the value of “**L4-03 - L4-04**”, or it is not higher than the value of **L4-03**.

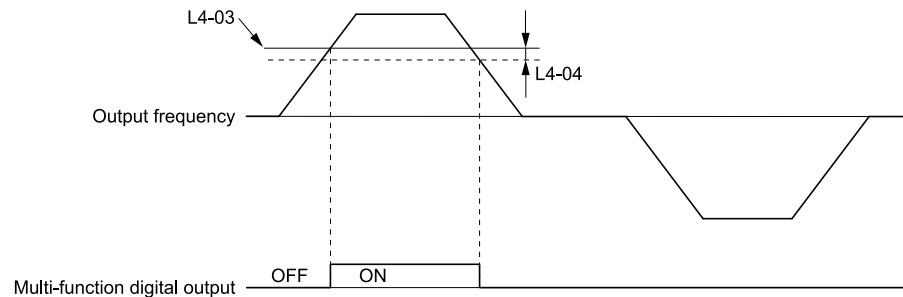


Figure 2.98 Example of Frequency Detection 4 (value of L4-03 Is Positive)

### ■ 17: Torque Detection 1 (N.C.)

| Setting Value | Function                  | Description  |
|---------------|---------------------------|--|
| 17            | Torque Detection 1 (N.C.) | <b>V/f</b> <b>CL-V/f</b> <b>OLV</b> <b>CLV</b> <b>AOLV</b> <b>OLV/PM</b> <b>AOLV/PM</b> <b>CLV/PM</b> <b>EZOLV</b><br>The terminal deactivates when the drive detects overtorque or undertorque. |

Use the **L6 [Torque Detection]** parameters to set torque detection.

**OFF** : The output current/torque is more than the torque value set with **L6-02 [Torque Detection Level 1]**, or the level is less than the torque value set with **L6-02** for longer than the time set with **L6-03 [Torque Detection Time 1]**.

**Note:**

- When  $L6-01 \geq 5$ , the drive will detect when the output current/torque is less than the detection level of **L6-02** for longer than the time set in **L6-03**.
- Refer to “L6: Torque Detection” for more information.

### ■ 18: Torque Detection 2 (N.O.)

| Setting Value | Function                  | Description  |
|---------------|---------------------------|--|
| 18            | Torque Detection 2 (N.O.) | <b>V/f</b> <b>CL-V/f</b> <b>OLV</b> <b>CLV</b> <b>AOLV</b> <b>OLV/PM</b> <b>AOLV/PM</b> <b>CLV/PM</b> <b>EZOLV</b><br>The terminal activates when the drive detects overtorque or undertorque. |

Use the **L6 [Torque Detection]** parameters to set torque detection.

**ON** : The output current/torque is more than the torque value set with **L6-05 [Torque Detection Level 2]**, or the level is less than the torque value set with **L6-05** for longer than the time set with **L6-06 [Torque Detection Time 2]**.

**Note:**

- When  $L6-04 \geq 5$ , the drive will detect when the output current/torque is less than the detection level of **L6-05** for longer than the time set in **L6-06**.
- Refer to “L6: Torque Detection” for more information.

### ■ 19: Torque Detection 2 (N.C.)

| Setting Value | Function                  | Description  |
|---------------|---------------------------|--|
| 19            | Torque Detection 2 (N.C.) | <b>V/f</b> <b>CL-V/f</b> <b>OLV</b> <b>CLV</b> <b>AOLV</b> <b>OLV/PM</b> <b>AOLV/PM</b> <b>CLV/PM</b> <b>EZOLV</b><br>The terminal deactivates when the drive detects overtorque or undertorque. |

Use the **L6 [Torque Detection]** parameters to set torque detection.

**OFF** : The output current/torque is more than the torque value set with **L6-05 [Torque Detection Level 2]**, or the level is less than the torque value set with **L6-05** for longer than the time set with **L6-06 [Torque Detection Time 2]**.

## 2.8 H: Terminal Functions

**Note:**

- When  $L6-04 \geq 5$ , the drive will detect when the output current/torque is less than the detection level of  $L6-05$  for longer than the time set in  $L6-06$ .
- Refer to “L6: Torque Detection” for more information.

### ■ 1A: During Reverse

| Setting Value | Function       | Description  |
|---------------|----------------|--|
| 1A            | During reverse | <div style="display: flex; justify-content: space-between; font-size: small;"> <span>V/f</span> <span>CL-V/f</span> <span>OLV</span> <span>CLV</span> <span>AOLV</span> <span>OLV/PM</span> <span>AOLV/PM</span> <span>CLV/PM</span> <span>EZOLV</span> </div> <p>The terminal activates when the motor operates in the reverse direction.</p> |

**ON :** The motor is operating in the reverse direction.

**OFF :** The motor is operating in the forward direction or the motor stopped.

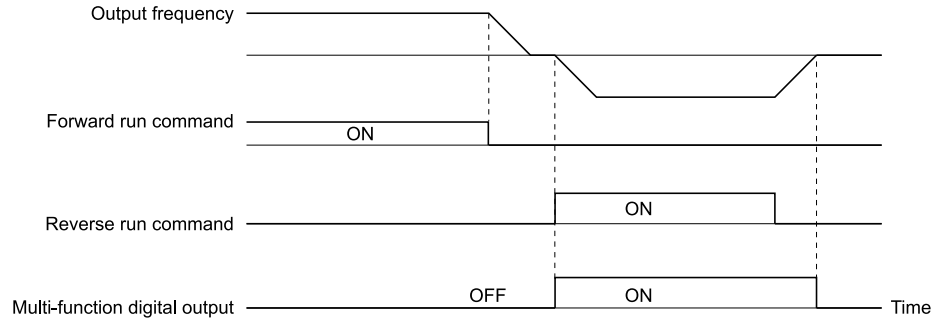


Figure 2.99 Reverse Operation Output Time Chart

### ■ 1B: During Baseblock (N.C.)

| Setting Value | Function                | Description  |
|---------------|-------------------------|--|
| 1B            | During Baseblock (N.C.) | <div style="display: flex; justify-content: space-between; font-size: small;"> <span>V/f</span> <span>CL-V/f</span> <span>OLV</span> <span>CLV</span> <span>AOLV</span> <span>OLV/PM</span> <span>AOLV/PM</span> <span>CLV/PM</span> <span>EZOLV</span> </div> <p>The terminal deactivates during baseblock. When the drive is in baseblock, the drive output transistor stops switching and does not make DC bus voltage.</p> |

**ON :** The drive is not in baseblock.

**OFF :** During baseblock

### ■ 1C: Motor 2 Selected

| Setting Value | Function          | Description  |
|---------------|-------------------|--|
| 1C            | Motor 2 Selection | <div style="display: flex; justify-content: space-between; font-size: small;"> <span>V/f</span> <span>CL-V/f</span> <span>OLV</span> <span>CLV</span> <span>AOLV</span> <span>OLV/PM</span> <span>AOLV/PM</span> <span>CLV/PM</span> <span>EZOLV</span> </div> <p>The terminal activates when motor 2 is selected.</p> |

**ON :** Motor 2 Selection

**OFF :** Motor 1 Selection

### ■ 1D: During Regeneration

| Setting Value | Function            | Description   |
|---------------|---------------------|---|
| 1D            | During Regeneration | <div style="display: flex; justify-content: space-between; font-size: small;"> <span>V/f</span> <span>CL-V/f</span> <span>OLV</span> <span>CLV</span> <span>AOLV</span> <span>OLV/PM</span> <span>AOLV/PM</span> <span>CLV/PM</span> <span>EZOLV</span> </div> <p>The terminal activates on when the motor is regenerating.</p> |

**ON :** Motor is regenerating.

**OFF :** Motor is operating or stopped.

### ■ 1E: Executing Auto-Restart

| Setting Value | Function               | Description   |
|---------------|------------------------|---|
| 1E            | Executing Auto-Restart | <div style="display: flex; justify-content: space-between; font-size: small;"> <span>V/f</span> <span>CL-V/f</span> <span>OLV</span> <span>CLV</span> <span>AOLV</span> <span>OLV/PM</span> <span>AOLV/PM</span> <span>CLV/PM</span> <span>EZOLV</span> </div> <p>The terminal activates when the Auto Restart function is trying to restart after a fault.</p> |

The terminal deactivates when the Auto Restart function automatically resets a fault. The terminal turns off when the Auto Restart function detects the fault again since Auto Restart function cannot function any longer due to number of attempts set with *L5-01 [Number of Auto Restart Attempts]* being reached.

**Note:**

For details, refer to "L5: Auto-Restart".

### ■ 1F: Motor Overload Alarm (oL1)

| Setting Value | Function                   | Description  |
|---------------|----------------------------|--|
| 1F            | Motor Overload Alarm (oL1) | <div style="display: flex; justify-content: space-between; align-items: center;"> <span>V/f</span> <span>CL-V/f</span> <span>OLV</span> <span>CLV</span> <span>AOLV</span> <span>OLV/PM</span> <span>AOLV/PM</span> <span>CLV/PM</span> <span>EZOLV</span> </div> <p>The terminal activates when the electronic thermal protection value of the motor overload protective function is a minimum of 90% of the detection level.</p> |

**Note:**

Refer to "L1-01: Motor Overload (oL1) Protection" for more information.

### ■ 20: Drive Overheat Pre-Alarm (oH)

| Setting Value | Function                      | Description   |
|---------------|-------------------------------|---|
| 20            | Drive Overheat Pre-Alarm (oH) | <div style="display: flex; justify-content: space-between; align-items: center;"> <span>V/f</span> <span>CL-V/f</span> <span>OLV</span> <span>CLV</span> <span>AOLV</span> <span>OLV/PM</span> <span>AOLV/PM</span> <span>CLV/PM</span> <span>EZOLV</span> </div> <p>The terminal activates when the drive heatsink temperature is at the level set with <i>L8-02 [Overheat Alarm Level]</i>.</p> |

**Note:**

Refer to "L8-02: Overheat Alarm Level" for more information.

### ■ 21: Safety Monitor Output Status

| Setting Value | Function                     | Description  |
|---------------|------------------------------|--|
| 21            | Safety Monitor Output Status | <div style="display: flex; justify-content: space-between; align-items: center;"> <span>V/f</span> <span>CL-V/f</span> <span>OLV</span> <span>CLV</span> <span>AOLV</span> <span>OLV/PM</span> <span>AOLV/PM</span> <span>CLV/PM</span> <span>EZOLV</span> </div> <p>The terminal turns on (safety stop state) when the safety circuit and safety diagnosis circuit are operating correctly and when terminals H1-HC and H2-HC are off (Open).</p> |

**Note:**

EDM = External Device Monitor

#### ON : Safety stop state

Terminals H1-HC and H2-HC are OFF (Open) (safety stop state).

#### OFF : Safety circuit fault or RUN/READY

Terminal H1-HC or terminal H2-HC is OFF (Open) (safety circuit fault), or the two terminals are ON or have short circuited (RUN/READY).

### ■ 22: Mechanical Weakening Detection

| Setting Value | Function                       | Description  |
|---------------|--------------------------------|--|
| 22            | Mechanical Weakening Detection | <div style="display: flex; justify-content: space-between; align-items: center;"> <span>V/f</span> <span>CL-V/f</span> <span>OLV</span> <span>CLV</span> <span>AOLV</span> <span>OLV/PM</span> <span>AOLV/PM</span> <span>CLV/PM</span> <span>EZOLV</span> </div> <p>The terminal activates when the drive detects mechanical weakening.</p> |

**Note:**

Refer to "Mechanical Weakening Detection Function" for more information.

### ■ 2F: Maintenance Notification

| Setting Value | Function                 | Description  |
|---------------|--------------------------|--|
| 2F            | Maintenance Notification | <div style="display: flex; justify-content: space-between; align-items: center;"> <span>V/f</span> <span>CL-V/f</span> <span>OLV</span> <span>CLV</span> <span>AOLV</span> <span>OLV/PM</span> <span>AOLV/PM</span> <span>CLV/PM</span> <span>EZOLV</span> </div> <p>The terminal activates when drive components are at their estimated maintenance period.</p> |

Tells the user about the maintenance period for these items:

- IGBT
- Cooling fan
- Capacitor
- Soft charge bypass relay

## 2.8 H: Terminal Functions

**Note:**

Refer to “Alarm Outputs for Maintenance Monitors” for more information.

### 30: During Torque Limit

| Setting Value | Function            | Description   |
|---------------|---------------------|---|
| 30            | During Torque Limit | <div style="display: flex; justify-content: space-between; align-items: center;"> <span>V/f</span> <span>CL-V/f</span> <span>OLV</span> <span>CLV</span> <span>AOLV</span> <span>OLV/PM</span> <span>AOLV/PM</span> <span>CLV/PM</span> <span>EZOLV</span> </div> <p>The terminal activates when the torque reference is the torque limit set with L7 parameters, H3-02, H3-06, or H3-10 [MFAI Function Selection].</p> |

**Note:**

Refer to “L7: Torque Limit” for more information.

### 31: During Speed Limit

| Setting Value | Function           | Description   |
|---------------|--------------------|---|
| 31            | During Speed Limit | <div style="display: flex; justify-content: space-between; align-items: center;"> <span>V/f</span> <span>CL-V/f</span> <span>OLV</span> <span>CLV</span> <span>AOLV</span> <span>OLV/PM</span> <span>AOLV/PM</span> <span>CLV/PM</span> <span>EZOLV</span> </div> <p>The terminal activates when the speed limit is active.</p> |

The speed limit activates and the terminal activates in these conditions:

- The frequency reference  $\geq$  d2-01 [Frequency Reference Upper Limit]
- The frequency reference  $\leq$  d2-02 [Frequency Reference Lower Limit] or d2-03 [Analog Frequency Ref Lower Limit].
- The frequency reference  $\leq$  E1-09 [Minimum Output Frequency] when b1-05 = 1, 2, or 3 [Operation Below Minimum Freq = Baseblock (Motor Coasts), Operate at Minimum Frequency, or Operate at Zero Speed].
- The frequency reference  $\leq$  Output Freq Lower Limit Level [H3-xx = 9] through analog input.

### 32: In Speed Limit During Trq Ctrl

| Setting Value | Function                       | Description   |
|---------------|--------------------------------|---|
| 32            | In Speed Limit During Trq Ctrl | <div style="display: flex; justify-content: space-between; align-items: center;"> <span>V/f</span> <span>CL-V/f</span> <span>OLV</span> <span>CLV</span> <span>AOLV</span> <span>OLV/PM</span> <span>AOLV/PM</span> <span>CLV/PM</span> <span>EZOLV</span> </div> <p>The motor accelerates in the forward direction or the reverse direction after enabling torque control and the externally input torque reference is disproportionate to the load. The output terminal activates when this speed is not higher than a constant speed and the motor speed is at the speed limit. This does not include operation when the drive is stopped.</p> |

**Note:**

Refer to “d5-03: Speed Limit Selection” for more information.

### 33: Zero Servo Complete

| Setting Value | Function            | Description   |
|---------------|---------------------|---|
| 33            | Zero Servo Complete | <div style="display: flex; justify-content: space-between; align-items: center;"> <span>V/f</span> <span>CL-V/f</span> <span>OLV</span> <span>CLV</span> <span>AOLV</span> <span>OLV/PM</span> <span>AOLV/PM</span> <span>CLV/PM</span> <span>EZOLV</span> </div> <p>The terminal activates when positioning in the range set with b9-02 [Zero Servo Completion Window] completes after sending the Zero-Servo command.</p> |

**Note:**

Refer to “b9: Zero Servo” for more information.

### 37: During Frequency Output

| Setting Value | Function                | Description   |
|---------------|-------------------------|---|
| 37            | During Frequency Output | <div style="display: flex; justify-content: space-between; align-items: center;"> <span>V/f</span> <span>CL-V/f</span> <span>OLV</span> <span>CLV</span> <span>AOLV</span> <span>OLV/PM</span> <span>AOLV/PM</span> <span>CLV/PM</span> <span>EZOLV</span> </div> <p>The terminal activates when the drive outputs frequency.</p> |

**ON :** The drive outputs frequency.

**OFF :** The drive does not output frequency.

**Note:**

The terminal deactivates in these conditions:

- During Stop
- During baseblock
- During DC Injection Braking (initial excitation)
- During Short Circuit Braking

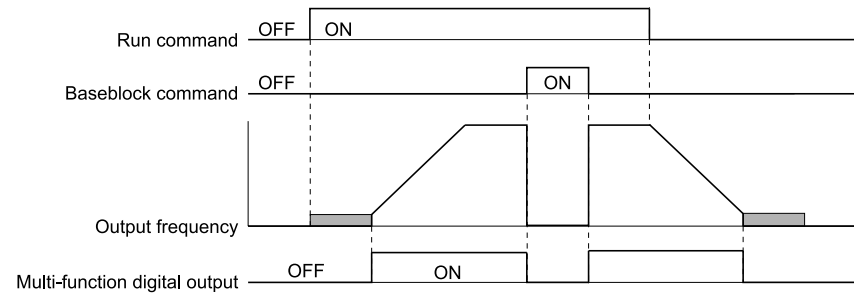


Figure 2.100 Active Frequency Output Time Chart

■ 38: Drive Enabled

| Setting Value | Function      | Description  |
|---------------|---------------|--|
| 38            | Drive Enabled | <b>V/f</b> <b>CL-V/f</b> <b>OLV</b> <b>CLV</b> <b>AOLV</b> <b>OLV/PM</b> <b>AOLV/PM</b> <b>CLV/PM</b> <b>EZOLV</b><br>This terminal activates when the H1-xx = 6A [Drive Enable] terminal activates. |

■ 39: Watt Hour Pulse Output

| Setting Value | Function               | Description  |
|---------------|------------------------|--|
| 39            | Watt Hour Pulse Output | <b>V/f</b> <b>CL-V/f</b> <b>OLV</b> <b>CLV</b> <b>AOLV</b> <b>OLV/PM</b> <b>AOLV/PM</b> <b>CLV/PM</b> <b>EZOLV</b><br>Outputs the pulse that shows the watt hours. |

**Note:**

Refer to “H2-06: Watt Hour Output Unit Selection” for more information.

■ 3C: LOCAL Control Selected

| Setting Value | Function               | Description  |
|---------------|------------------------|--|
| 3C            | LOCAL Control Selected | <b>V/f</b> <b>CL-V/f</b> <b>OLV</b> <b>CLV</b> <b>AOLV</b> <b>OLV/PM</b> <b>AOLV/PM</b> <b>CLV/PM</b> <b>EZOLV</b><br>The terminal activates when the Run command source or frequency reference source is LOCAL. |

**ON : LOCAL**

The keypad is the Run command source or the frequency reference source.

**OFF : REMOTE**

The Run command source or frequency reference source is an external source set with b1-01 [Frequency Reference Selection 1], b1-15 [Frequency Reference Selection 2], b1-02 [Run Command Selection 1], or b1-16 [Run Command Selection 2].

■ 3D: During Speed Search

| Setting Value | Function            | Description  |
|---------------|---------------------|--|
| 3D            | During Speed Search | <b>V/f</b> <b>CL-V/f</b> <b>OLV</b> <b>CLV</b> <b>AOLV</b> <b>OLV/PM</b> <b>AOLV/PM</b> <b>CLV/PM</b> <b>EZOLV</b><br>The terminal activates when the drive is doing speed search. |

**Note:**

Refer to “b3: Speed Search” for more information.

■ 3E: PID Feedback Low

| Setting Value | Function         | Description  |
|---------------|------------------|--|
| 3E            | PID Feedback Low | <b>V/f</b> <b>CL-V/f</b> <b>OLV</b> <b>CLV</b> <b>AOLV</b> <b>OLV/PM</b> <b>AOLV/PM</b> <b>CLV/PM</b> <b>EZOLV</b><br>The terminal activates when the drive detects FbL [PID Feedback Loss]. |

The drive detects FbL [PID Feedback Loss] when the PID feedback value < b5-13 [PID Feedback Loss Detection Lvl] for longer than the time set in b5-14 [PID Feedback Loss Detection Time].

**Note:**

Refer to “PID Feedback Loss Detection” for more information.

## 2.8 H: Terminal Functions

### ■ 3F: PID Feedback High

| Setting Value | Function          | Description  |
|---------------|-------------------|--|
| 3F            | PID Feedback High | <input type="checkbox"/> V/f <input type="checkbox"/> CL-V/f <input type="checkbox"/> OLV <input type="checkbox"/> CLV <input type="checkbox"/> AOLV <input type="checkbox"/> OLV/PM <input type="checkbox"/> AOLV/PM <input type="checkbox"/> CLV/PM <input type="checkbox"/> EZOLV<br>The terminal activates when the drive detects <i>FbH</i> [Excessive PID Feedback]. |

The drive detects *FbH* [Excessive PID Feedback] when the PID feedback value > *b5-36* [PID High Feedback Detection Lvl] for longer than the time set in *b5-37* [PID High Feedback Detection Time].

**Note:**

Refer to “PID Feedback Loss Detection” for more information.

### ■ 4A: During KEB Ride-Thru

| Setting Value | Function             | Description   |
|---------------|----------------------|---|
| 4A            | During KEB Ride-Thru | <input type="checkbox"/> V/f <input type="checkbox"/> CL-V/f <input type="checkbox"/> OLV <input type="checkbox"/> CLV <input type="checkbox"/> AOLV <input type="checkbox"/> OLV/PM <input type="checkbox"/> AOLV/PM <input type="checkbox"/> CLV/PM <input type="checkbox"/> EZOLV<br>The activates during KEB Ride-Thru. |

**Note:**

Refer to “KEB Ride-Thru function” for more information.

### ■ 4B: During Short Circuit Braking

| Setting Value | Function                     | Description  |
|---------------|------------------------------|--|
| 4B            | During Short Circuit Braking | <input type="checkbox"/> V/f <input type="checkbox"/> CL-V/f <input type="checkbox"/> OLV <input type="checkbox"/> CLV <input type="checkbox"/> AOLV <input checked="" type="checkbox"/> OLV/PM <input checked="" type="checkbox"/> AOLV/PM <input checked="" type="checkbox"/> CLV/PM <input checked="" type="checkbox"/> EZOLV<br>The terminal activates during Short Circuit Braking. |

**Note:**

- When *A1-02* = 8 [Control Method Selection = EZOLV], this function is available if you use a PM motor.
- For details, refer to "b2: DC Injection Braking and Short Circuit Braking".

### ■ 4C: During Fast Stop

| Setting Value | Function         | Description  |
|---------------|------------------|--|
| 4C            | During Fast Stop | <input type="checkbox"/> V/f <input type="checkbox"/> CL-V/f <input type="checkbox"/> OLV <input type="checkbox"/> CLV <input type="checkbox"/> AOLV <input type="checkbox"/> OLV/PM <input type="checkbox"/> AOLV/PM <input type="checkbox"/> CLV/PM <input type="checkbox"/> EZOLV<br>The terminal activates when the fast stop is in operation. |

### ■ 4D: oH Pre-Alarm Reduction Limit

| Setting Value | Function                | Description  |
|---------------|-------------------------|--|
| 4D            | oH Pre-Alarm Time Limit | <input type="checkbox"/> V/f <input type="checkbox"/> CL-V/f <input type="checkbox"/> OLV <input type="checkbox"/> CLV <input type="checkbox"/> AOLV <input type="checkbox"/> OLV/PM <input type="checkbox"/> AOLV/PM <input type="checkbox"/> CLV/PM <input type="checkbox"/> EZOLV<br>The terminal activates when <i>L8-03</i> = 4 [Overheat Pre-Alarm Selection = Operate at Reduced Speed (L8-19)] and <i>oH</i> [Heatsink Overheat] does not clear after the drive decreases the frequency for 10 cycles. |

**Note:**

Refer to “L8-03: Overheat Pre-Alarm Selection” for more information.

### ■ 4E: Braking Transistor Fault (rr)

| Setting Value | Function                      | Description  |
|---------------|-------------------------------|--|
| 4E            | Braking Transistor Fault (rr) | <input type="checkbox"/> V/f <input type="checkbox"/> CL-V/f <input type="checkbox"/> OLV <input type="checkbox"/> CLV <input type="checkbox"/> AOLV <input type="checkbox"/> OLV/PM <input type="checkbox"/> AOLV/PM <input type="checkbox"/> CLV/PM <input type="checkbox"/> EZOLV<br>The terminal activates when the internal braking transistor overheats and the drive detects an <i>rr</i> [Dynamic Braking Transistor Fault] fault. |

### ■ 4F: Braking Resistor Overheat (rH)

| Setting Value | Function                       | Description  |
|---------------|--------------------------------|--|
| 4F            | Braking Resistor Overheat (rH) | <input type="checkbox"/> V/f <input type="checkbox"/> CL-V/f <input type="checkbox"/> OLV <input type="checkbox"/> CLV <input type="checkbox"/> AOLV <input type="checkbox"/> OLV/PM <input type="checkbox"/> AOLV/PM <input type="checkbox"/> CLV/PM <input type="checkbox"/> EZOLV<br>The terminal activates when the braking resistor overheats and the drive detects an <i>rH</i> [Braking Resistor Overheat] fault. |

The braking resistor overheats when the deceleration time is short and there is too much motor regeneration energy.



■ 60: Internal Cooling Fan Failure

| Setting Value | Function                   | Description   |
|---------------|----------------------------|---|
| 60            | Internal Cooling Fan Alarm | <b>V/f</b> <b>CL-V/f</b> <b>OLV</b> <b>CLV</b> <b>AOLV</b> <b>OLV/PM</b> <b>AOLV/PM</b> <b>CLV/PM</b> <b>EZOLV</b><br>The terminal activates when the drive detects a cooling fan failure in the drive. |

■ 61: Pole Position Detection Complete

| Setting Value | Function                         | Description  |
|---------------|----------------------------------|--|
| 61            | Pole Position Detection Complete | <b>V/f</b> <b>CL-V/f</b> <b>OLV</b> <b>CLV</b> <b>AOLV</b> <b>OLV/PM</b> <b>AOLV/PM</b> <b>CLV/PM</b> <b>EZOLV</b><br>The terminal activates when drive receives a Run command and the drive detects the motor magnetic pole position of the PM motor. |

■ 62: Modbus Reg 1 Status Satisfied

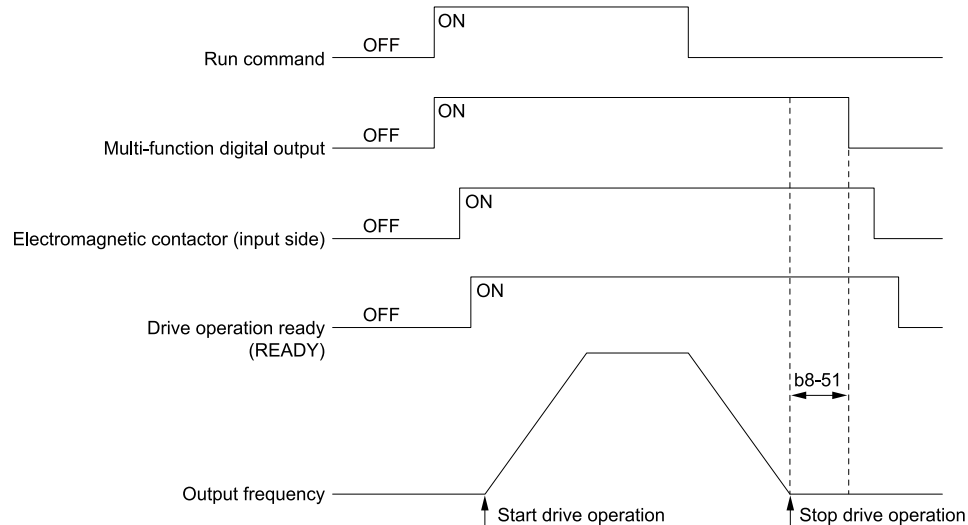
| Setting Value | Function                      | Description   |
|---------------|-------------------------------|---|
| 62            | Modbus Reg 1 Status Satisfied | <b>V/f</b> <b>CL-V/f</b> <b>OLV</b> <b>CLV</b> <b>AOLV</b> <b>OLV/PM</b> <b>AOLV/PM</b> <b>CLV/PM</b> <b>EZOLV</b><br>The terminal activates when the bit specified by H2-08 [Modbus Register 1 Bit Select] for the MEMOBUS register address set with H2-07 [Modbus Register 1 Address Select] activates. |

■ 63: Modbus Reg 2 Status Satisfied

| Setting Value | Function                      | Description   |
|---------------|-------------------------------|---|
| 63            | Modbus Reg 2 Status Satisfied | <b>V/f</b> <b>CL-V/f</b> <b>OLV</b> <b>CLV</b> <b>AOLV</b> <b>OLV/PM</b> <b>AOLV/PM</b> <b>CLV/PM</b> <b>EZOLV</b><br>The terminal activates when the bit specified by H2-10 [Modbus Register 2 Bit Select] for the MEMOBUS register address set with H2-09 [Modbus Register 2 Address Select] activates. |

■ 65: Standby Output

| Setting Value | Function       | Description  |
|---------------|----------------|--|
| 65            | Standby Output | <b>V/f</b> <b>CL-V/f</b> <b>OLV</b> <b>CLV</b> <b>AOLV</b> <b>OLV/PM</b> <b>AOLV/PM</b> <b>CLV/PM</b> <b>EZOLV</b><br>The terminal deactivates after the drive stops operating and after the time set with b8-51 [Standby Mode Wait Time]. |



**ON** : The Run command turns on and the magnetic contactor on the input side turns on.  
**OFF** : The Run command turns off and the drive stops operating. Then, the magnetic contactor on the input side turns off after the time set with *b8-51* [Standby Mode Wait Time] elapses.

■ 66: Comparator1

| Setting Value | Function    | Description  |
|---------------|-------------|--|
| 66            | Comparator1 | <b>V/f</b> <b>CL-V/f</b> <b>OLV</b> <b>CLV</b> <b>AOLV</b> <b>OLV/PM</b> <b>AOLV/PM</b> <b>CLV/PM</b> <b>EZOLV</b><br>The terminal activates if the monitor value set with H2-20 [Comparator 1 Monitor Selection] is in range of the values of H2-21 [Comparator 1 Lower Limit] and H2-22 [Comparator 1 Upper Limit] for the time set with H2-24 [Comparator 1 On-Delay Time]. |

Parameter Details

## 2.8 H: Terminal Functions

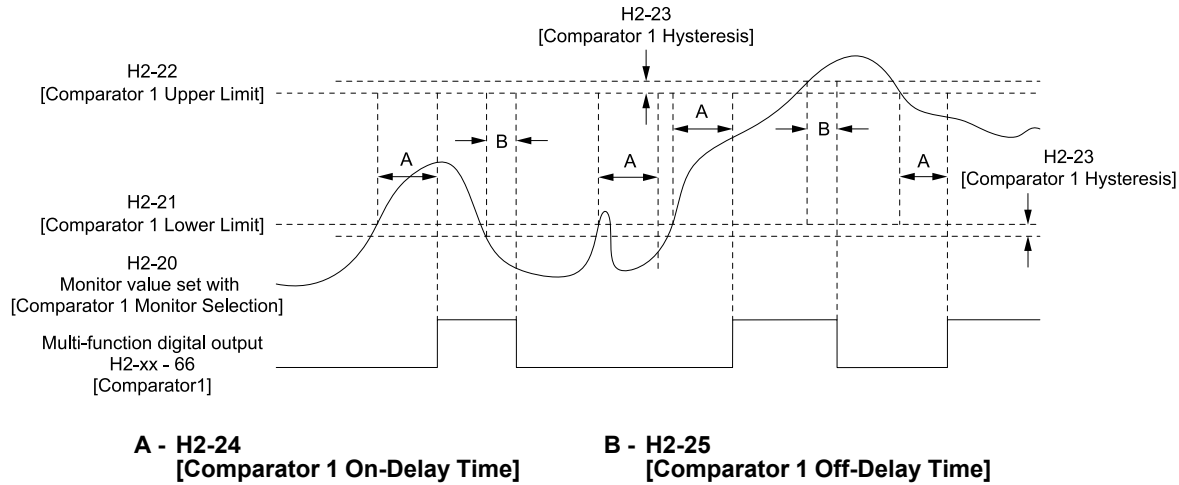


Figure 2.101 Comparator 1 Output Time Chart

**Note:**

The drive compares the monitors set with *H2-20* as absolute values.

### 67: Comparator2

| Setting Value | Function    | Description  |
|---------------|-------------|--|
| 67            | Comparator2 | <div style="display: flex; justify-content: space-between; font-size: small;"> <span>V/f</span> <span>CL-V/f</span> <span>OLV</span> <span>CLV</span> <span>AOLV</span> <span>OLV/PM</span> <span>AOLV/PM</span> <span>CLV/PM</span> <span>EZOLV</span> </div> <p>The terminal activates if the monitor value set with <i>H2-26</i> [Comparator 2 Monitor Selection] is not in the range of the values of <i>H2-27</i> [Comparator 2 Lower Limit] and <i>H2-28</i> [Comparator 2 Upper Limit] for the time set with <i>H2-30</i> [Comparator 2 On-Delay Time].</p> |

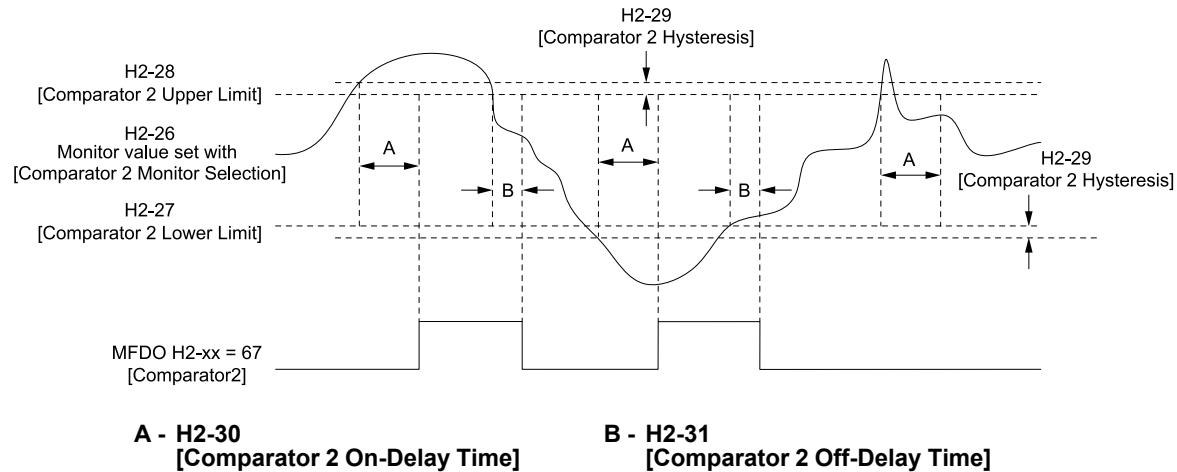


Figure 2.102 Comparator 2 Output Time Chart

**Note:**

The drive compares the monitors set with *H2-26* as absolute values.

### 69: External Power 24V Supply

| Setting Value | Function                  | Description  |
|---------------|---------------------------|--|
| 69            | External Power 24V Supply | <div style="display: flex; justify-content: space-between; font-size: small;"> <span>V/f</span> <span>CL-V/f</span> <span>OLV</span> <span>CLV</span> <span>AOLV</span> <span>OLV/PM</span> <span>AOLV/PM</span> <span>CLV/PM</span> <span>EZOLV</span> </div> <p>The terminal activates when there is an external 24V power supply between terminals PS-AC.</p> |

**ON :** An external 24V power supply supplies power.

**OFF :** An external 24V power supply does not supply power.

■ **6A: Data Logger Error**

| Setting Value | Function          | Description   |
|---------------|-------------------|---|
| 6A            | Data Logger Error | <b>V/f</b> <b>CL-V/f</b> <b>OLV</b> <b>CLV</b> <b>AOLV</b> <b>OLV/PM</b> <b>AOLV/PM</b> <b>CLV/PM</b> <b>EZOLV</b><br>The terminal activates when the drive detects a LoG [Com Error / Abnormal SD card]. |

■ **90 to 93: DWEZ Digital Outputs 1 to 4**

| Setting Value | Function                   | Description   |
|---------------|----------------------------|---|
| 90 - 93       | DWEZ Digital Output 1 to 4 | <b>V/f</b> <b>CL-V/f</b> <b>OLV</b> <b>CLV</b> <b>AOLV</b> <b>OLV/PM</b> <b>AOLV/PM</b> <b>CLV/PM</b> <b>EZOLV</b><br>Sets the DriveWorksEZ digital output. Refer to the DriveWorksEZ online manual for more information. |

■ **A0 to A7: DWEZ Extended Digital Output 1 to 8**

| Setting Value | Function                            | Description   |
|---------------|-------------------------------------|---|
| A0 to A7      | DWEZ Extended Digital Output 1 to 8 | <b>V/f</b> <b>CL-V/f</b> <b>OLV</b> <b>CLV</b> <b>AOLV</b> <b>OLV/PM</b> <b>AOLV/PM</b> <b>CLV/PM</b> <b>EZOLV</b><br>Sets the digital output for the DriveWorksEZ DO-A3 option card. Refer to the DriveWorksEZ online manual for more information. |

■ **100 to 1A7: Inverse output of 0 to A7**

| Setting Value | Function                  | Description  |
|---------------|---------------------------|--|
| 100 to 1A7    | Inverse output of 0 to A7 | <b>V/f</b> <b>CL-V/f</b> <b>OLV</b> <b>CLV</b> <b>AOLV</b> <b>OLV/PM</b> <b>AOLV/PM</b> <b>CLV/PM</b> <b>EZOLV</b><br>Causes inverse output of the function for the selected MFDO. Uses the last two digits of 1xx to select which function to inversely output. |

For example, set  $H2-xx = 10E$  for the inverse output of  $E$  [Fault].

◆ **H3: Analog Inputs**

**WARNING!** Sudden Movement Hazard. Do test runs and examine the drive to make sure that the command references are correct. If you set the command reference incorrectly, it can cause damage to the drive or serious injury or death.

Drives have three analog input terminals, terminals A1, A2, and A3. *H3 parameters* select the functions set to these analog input terminals and adjust signal levels.

Table 2.64 shows the functions that you can set to analog input terminals. Use *H3-02, H3-06, and H3-10 [MFAI Function Select]* to set functions.

**Table 2.64 Multi-Function Analog Input Terminal Settings**

| Setting Value | Function                        | Reference | Setting Value | Function                        | Reference |
|---------------|---------------------------------|-----------|---------------|---------------------------------|-----------|
| 0             | Frequency Reference             | 422       | E             | Motor Temperature (PTC Input)   | 425       |
| 1             | Frequency Gain                  | 422       | F             | Through Mode                    | 425       |
| 2             | Auxiliary Frequency Reference 1 | 422       | 10            | Forward Torque Limit            | 425       |
| 3             | Auxiliary Frequency Reference 2 | 423       | 11            | Reverse Torque Limit            | 426       |
| 4             | Output Voltage Bias             | 423       | 12            | Regenerative Torque Limit       | 427       |
| 5             | Accel/Decel Time Gain           | 423       | 13            | Torque Reference / Torque Limit | 427       |
| 6             | DC Injection Braking Current    | 423       | 14            | Torque Compensation             | 427       |
| 7             | Torque Detection Level          | 424       | 15            | General Torque Limit            | 427       |
| 8             | Stall Prevent Level during Run  | 424       | 16            | PID DifferentialFdbk            | 427       |
| 9             | Output Frequency Lower Limit    | 424       | 1F            | Through Mode                    | 427       |
| B             | PID Feedback                    | 424       | 30            | DWEZ Analog Input 1             | 427       |
| C             | PID Setpoint                    | 425       | 31            | DWEZ Analog Input 2             | 427       |
| D             | Frequency Bias                  | 425       | 32            | DWEZ Analog Input 3             | 428       |

**Note:**

All analog input scaling uses gain and bias for adjustment. Set the gain and bias values correctly.

## 2.8 H: Terminal Functions

| Example Analog Input Settings                         | Setting of Terminal A1  | Frequency Reference  |
|---|---|--|
| Frequency reference with the gain setting adjusted    | <ul style="list-style-type: none"> <li>H3-02 = 0 [Terminal A1 Function Selection = Frequency Reference]</li> <li>H3-03: 200.0 [Terminal A1 Gain Setting = 200%]</li> <li>H3-04 = 0.0 [Terminal A1 Bias Setting = 0.0%]</li> </ul> | <ul style="list-style-type: none"> <li>When you input a 10 V signal, the frequency reference will be 200%.</li> <li>When you input a 5 V signal, the frequency reference will be 100%.</li> </ul> <p>When you input a 5 V or more signal, the drive output will be limited by E1-04 [Maximum Output Frequency] and the frequency reference will be 100%.</p> <div style="display: flex; justify-content: space-around;"> <div style="text-align: center;"> <p>H3-01 = 0</p> </div> <div style="text-align: center;"> <p>H3-01 = 1</p> </div> </div>  |
| Frequency reference with the negative number bias set | <ul style="list-style-type: none"> <li>H3-02 = 0 [Frequency Reference]</li> <li>H3-03 = 100.0 [ 100.0% ]</li> <li>H3-04 = -25.0 [ -25.0% ]</li> </ul>   | <ul style="list-style-type: none"> <li>When you input a 0 V signal, the frequency reference will be -25%.</li> <li>When H3-01 = 0 [Terminal A1 Signal Level Select = 0 to 10V (Lower Limit at 0)]: <ul style="list-style-type: none"> <li>When you input a 0 V to 2 V signal, the frequency reference will be 0%.</li> <li>When you input a 2 V to 10 V signal, the frequency reference will be 0% to 100%.</li> </ul> </li> <li>When H3-01 = 1 [-10 to +10V (Bipolar Reference)]: <ul style="list-style-type: none"> <li>When you input a 0 V to 2 V signal, it enables signals of positive and negative polarities and the motor rotates in reverse.</li> </ul> </li> </ul> <div style="display: flex; justify-content: space-around;"> <div style="text-align: center;"> <p>H3-01 = 0</p> </div> <div style="text-align: center;"> <p>H3-01 = 1</p> </div> </div> |

### MEMOBUS/Modbus Multi-Function A1 to 3 Function Selection

Let the MFAI function be assigned to MEMOBUS/Modbus register 15C1 to 15C3 (Hex.) [Mbus Reg 15C1h through 15C3h Input Function]. Use H3-40 to H3-42 [Mbus Reg 15C1h through 15C3h Input Function] to set the function and use H3-43 [Mbus Reg Inputs FilterTime Const] to set the input filter.

Table 2.65 MEMOBUS Multi-Function AI Command Register

| Register No. (Hex.) | Name                          | Range *1        | Parameter |
|---------------------|-------------------------------|-----------------|-----------|
| 15C1                | Mbus Reg 15C1h Input Function | -32767 to 32767 | H3-40     |
| 15C2                | Mbus Reg 15C2h Input Function | -32767 to 32767 | H3-41     |
| 15C3                | Mbus Reg 15C3h Input Function | -32767 to 32767 | H3-42     |

\*1 Set as 100% = 4096.

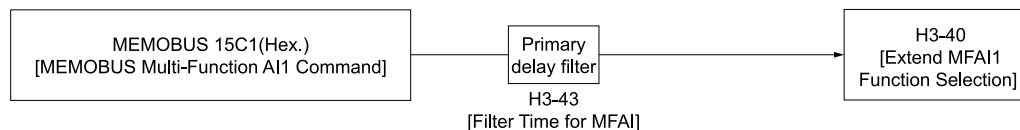


Figure 2.103 Functional Block Diagram for MEMOBUS Multi-Function AI Command 1

**Note:**

- Refer to H3-xx “MFAI Setting Values” for the analog input setting values.
- When you will not use the terminal, set  $H3-40$  to  $H3-42 = F$ . The through mode function is not supported.
- You cannot use  $H3-40$  to  $H3-42$  to set these MFAI terminals:

| H3-xx Setting Value | Function                        |
|---------------------|---------------------------------|
| 0                   | Frequency Reference             |
| 1                   | Frequency Gain                  |
| 2                   | Auxiliary Frequency Reference 1 |
| 3                   | Auxiliary Frequency Reference 2 |
| 30                  | DWEZ Analog Input 1             |
| 31                  | DWEZ Analog Input 2             |
| 32                  | DWEZ Analog Input 3             |

## ◆ H3: MFAI Parameters

### ■ H3-01: Terminal A1 Signal Level Select

| No. (Hex.)   | Name                            | Description   | Default (Range) |
|--------------|---------------------------------|---|-----------------|
| H3-01 (0410) | Terminal A1 Signal Level Select | <span>V/f</span> <span>CL-V/f</span> <span>OLV</span> <span>CLV</span> <span>AOLV</span> <span>OLV/PM</span> <span>AOLV/PM</span> <span>CLV/PM</span> <span>EZOLV</span><br>Sets the input signal level for MFAI terminal A1. | 0<br>(0 - 3)    |

#### 0 : 0 to 10V (Lower Limit at 0)

The voltage signal is 0 Vdc to 10 Vdc. The minimum input level limit is 0%. The drive will read a negative input signal caused by gain and bias settings as 0%.

#### 1 : -10 to +10V (Bipolar Reference)

The voltage signal is -10 Vdc to 10 Vdc. This setting enables positive and negative polarity signals. When the drive uses this setting as the frequency reference, a Forward Run command will run the motor in reverse and a Reverse Run command will run the motor forward. The gain and bias settings will cause the signal to be a negative number.

#### 2 : 4 to 20 mA

The current signal is 4 mA to 20 mA. The minimum input level limit is 0%. The drive will read a negative input signal caused by gain and bias settings as 0%.

#### 3 : 0 to 20 mA

The current signal is 0 mA to 20 mA. The minimum input level limit is 0%. The drive will read a negative input signal caused by gain and bias settings as 0%.

**Note:**

When  $H3-01 = 0, 1$ , set DIP switch S1-1 to the V side (voltage). When  $H3-01 = 2, 3$ , set DIP switch S1-1 to the I side (current). The default setting is the V side (voltage).

### ■ H3-02: Terminal A1 Function Selection

| No. (Hex.)   | Name                           | Description   | Default (Range) |
|--------------|--------------------------------|---|-----------------|
| H3-02 (0434) | Terminal A1 Function Selection | <span>V/f</span> <span>CL-V/f</span> <span>OLV</span> <span>CLV</span> <span>AOLV</span> <span>OLV/PM</span> <span>AOLV/PM</span> <span>CLV/PM</span> <span>EZOLV</span><br>Sets the function for MFAI terminal A1. | 0<br>(0 - 32)   |

### ■ H3-03: Terminal A1 Gain Setting

| No. (Hex.)          | Name                     | Description   | Default (Range)              |
|---------------------|--------------------------|---|------------------------------|
| H3-03 (0411)<br>RUN | Terminal A1 Gain Setting | <span>V/f</span> <span>CL-V/f</span> <span>OLV</span> <span>CLV</span> <span>AOLV</span> <span>OLV/PM</span> <span>AOLV/PM</span> <span>CLV/PM</span> <span>EZOLV</span><br>Sets the gain of the analog signal input to MFAI terminal A1. | 100.0%<br>(-999.9 - +999.9%) |

## 2.8 H: Terminal Functions

This parameter sets the quantity of reference for the function set for terminal A1 as a percentage when 10 V (or 20 mA) is input.

Use this parameter and *H3-04 [Terminal A1 Bias Setting]* to adjust the characteristics of the analog input signal to terminal A1.

### ■ H3-04: Terminal A1 Bias Setting

| No.<br>(Hex.)          | Name                     | Description  | Default<br>(Range)         |
|------------------------|--------------------------|--|----------------------------|
| H3-04<br>(0412)<br>RUN | Terminal A1 Bias Setting | <div style="display: flex; gap: 5px;"> <span>V/f</span> <span>CL-V/f</span> <span>OLV</span> <span>CLV</span> <span>AOLV</span> <span>OLV/PM</span> <span>AOLV/PM</span> <span>CLV/PM</span> <span>EZOLV</span> </div> Sets the bias of the analog signal input to MFAI terminal A1. | 0.0%<br>(-999.9 - +999.9%) |

This parameter sets the bias for the function set for terminal A1 as a percentage when 0 V (4 mA or 0 mA) is input.

Use this parameter and *H3-03 [Terminal A1 Gain Setting]* to adjust the characteristics of the analog input signal to terminal A1.

### ■ H3-05: Terminal A3 Signal Level Select

| No.<br>(Hex.)   | Name                            | Description  | Default<br>(Range) |
|-----------------|---------------------------------|--|--------------------|
| H3-05<br>(0413) | Terminal A3 Signal Level Select | <div style="display: flex; gap: 5px;"> <span>V/f</span> <span>CL-V/f</span> <span>OLV</span> <span>CLV</span> <span>AOLV</span> <span>OLV/PM</span> <span>AOLV/PM</span> <span>CLV/PM</span> <span>EZOLV</span> </div> Sets the input signal level for MFAI terminal A3. | 0<br>(0 - 3)       |

#### 0 : 0-10V (LowLim=0)

The voltage signal is 0 Vdc to 10 Vdc. The minimum input level limit is 0%. The drive will read a negative input signal caused by gain and bias settings as 0%.

#### 1 : -10 to +10V (Bipolar Reference)

The voltage signal is -10 Vdc to 10 Vdc. This setting enables positive and negative polarity signals. When the drive uses this setting as the frequency reference, a Forward Run command will run the motor in reverse and a Reverse Run command will run the motor forward. The gain and bias settings will cause the signal to be a negative number.

#### 2 : 4 to 20 mA

The current signal is 4 mA to 20 mA. The minimum input level limit is 0%. The drive will read a negative input signal caused by gain and bias settings as 0%.

#### 3 : 0 to 20 mA

The current signal is 0 mA to 20 mA. The minimum input level limit is 0%. The drive will read a negative input signal caused by gain and bias settings as 0%.

**Note:**

When *H3-05* = 0, 1, set DIP switch S1-3 to the V side (voltage). When *H3-05* = 2, 3, set DIP switch S1-3 to the I side (current). The default setting is the V side (voltage).

### ■ H3-06: Terminal A3 Function Selection

| No.<br>(Hex.)   | Name                           | Description  | Default<br>(Range) |
|-----------------|--------------------------------|--|--------------------|
| H3-06<br>(0414) | Terminal A3 Function Selection | <div style="display: flex; gap: 5px;"> <span>V/f</span> <span>CL-V/f</span> <span>OLV</span> <span>CLV</span> <span>AOLV</span> <span>OLV/PM</span> <span>AOLV/PM</span> <span>CLV/PM</span> <span>EZOLV</span> </div> Sets the function for MFAI terminal A3. | 2<br>(0 - 32)      |

**Note:**

- When terminal A3 is the PTC input terminal:
- Set H3-06 = E [Motor Temperature (PTC input)]
  - Set DIP switch S4 to the PTC side
  - Set DIP switch S1-3 to the V side

### ■ H3-07: Terminal A3 Gain Setting

| No. (Hex.)             | Name                     | Description  | Default (Range)              |
|------------------------|--------------------------|--|------------------------------|
| H3-07<br>(0415)<br>RUN | Terminal A3 Gain Setting | <div style="display: flex; gap: 5px;"> <span>V/f</span> <span>CL-V/f</span> <span>OLV</span> <span>CLV</span> <span>AOLV</span> <span>OLV/PM</span> <span>AOLV/PM</span> <span>CLV/PM</span> <span>EZOLV</span> </div> Sets the gain of the analog signal input to MFAI terminal A3. | 100.0%<br>(-999.9 - +999.9%) |

When 10 V (or 20 mA) is input, this parameter sets the reference quantity for the function set for terminal A3 as a percentage.

Use this parameter and *H3-08 [Terminal A3 Bias Setting]* to adjust the characteristics of the analog input signal to terminal A3.

### ■ H3-08: Terminal A3 Bias Setting

| No. (Hex.)             | Name                     | Description  | Default (Range)            |
|------------------------|--------------------------|--|----------------------------|
| H3-08<br>(0416)<br>RUN | Terminal A3 Bias Setting | <div style="display: flex; gap: 5px;"> <span>V/f</span> <span>CL-V/f</span> <span>OLV</span> <span>CLV</span> <span>AOLV</span> <span>OLV/PM</span> <span>AOLV/PM</span> <span>CLV/PM</span> <span>EZOLV</span> </div> Sets the bias of the analog signal input to MFAI terminal A3. | 0.0%<br>(-999.9 - +999.9%) |

When 0 V (4 mA or 0 mA) is input, this parameter sets the bias for the function set for terminal A3 as a percentage.

Use this parameter and *H3-07 [Terminal A3 Gain Setting]* to adjust the characteristics of the analog input signal to terminal A3.

### ■ H3-09: Terminal A2 Signal Level Select

| No. (Hex.)      | Name                            | Description  | Default (Range) |
|-----------------|---------------------------------|--|-----------------|
| H3-09<br>(0417) | Terminal A2 Signal Level Select | <div style="display: flex; gap: 5px;"> <span>V/f</span> <span>CL-V/f</span> <span>OLV</span> <span>CLV</span> <span>AOLV</span> <span>OLV/PM</span> <span>AOLV/PM</span> <span>CLV/PM</span> <span>EZOLV</span> </div> Sets the input signal level for MFAI terminal A2. | 2<br>(0 - 3)    |

#### 0 : 0-10V (LowLim=0)

The voltage signal is 0 Vdc to 10 Vdc. The minimum input level is limited to 0%, so that a negative input signal due to gain and bias settings will be read as 0%.

#### 1 : -10 to +10V (Bipolar Reference)

The voltage signal is -10 Vdc to 10 Vdc. Signals of both positive and negative polarities are enabled. When this setting is used as the frequency reference, the motor runs reverse when the Forward run command is input, or runs forward when the Reverse run signal is input, while the signal is a negative number due to gain and bias.

#### 2 : 4 to 20 mA

The current signal is 4 mA to 20 mA. The minimum input level is limited to 0%, so that a negative input signal due to gain and bias settings will be read as 0%.

#### 3 : 0 to 20 mA

The current signal is 0 mA to 20 mA. The minimum input level is limited to 0%, so that a negative input signal due to gain and bias settings will be read as 0%.

#### Note:

When *H3-09 = 0, 1*, set DIP switch S1-2 to the V side (voltage). When *H3-09 = 2, 3*, set DIP switch S1-2 to the I side (current). The default setting is the I side (current).

### ■ H3-10: Terminal A2 Function Selection

| No. (Hex.)      | Name                           | Description  | Default (Range) |
|-----------------|--------------------------------|--|-----------------|
| H3-10<br>(0418) | Terminal A2 Function Selection | <div style="display: flex; gap: 5px;"> <span>V/f</span> <span>CL-V/f</span> <span>OLV</span> <span>CLV</span> <span>AOLV</span> <span>OLV/PM</span> <span>AOLV/PM</span> <span>CLV/PM</span> <span>EZOLV</span> </div> Sets the function for MFAI terminal A2. | 0<br>(0 - 32)   |

## 2.8 H: Terminal Functions

### ■ H3-11: Terminal A2 Gain Setting

| No.<br>(Hex.)          | Name                     | Description   | Default<br>(Range)           |
|------------------------|--------------------------|---|------------------------------|
| H3-11<br>(0419)<br>RUN | Terminal A2 Gain Setting | <b>V/f</b> <b>CL-V/f</b> <b>OLV</b> <b>CLV</b> <b>AOLV</b> <b>OLV/PM</b> <b>AOLV/PM</b> <b>CLV/PM</b> <b>EZOLV</b><br>Sets the gain of the analog signal input to MFAI terminal A2. | 100.0%<br>(-999.9 - +999.9%) |

When 10 V (or 20 mA) is input, this parameter sets the reference quantity for the function set for terminal A2 as a percentage.

Use this parameter and *H3-12 [Terminal A2 Bias Setting]* to adjust the characteristics of the analog input signal to terminal A2.

### ■ H3-12: Terminal A2 Bias Setting

| No.<br>(Hex.)          | Name                     | Description   | Default<br>(Range)         |
|------------------------|--------------------------|---|----------------------------|
| H3-12<br>(041A)<br>RUN | Terminal A2 Bias Setting | <b>V/f</b> <b>CL-V/f</b> <b>OLV</b> <b>CLV</b> <b>AOLV</b> <b>OLV/PM</b> <b>AOLV/PM</b> <b>CLV/PM</b> <b>EZOLV</b><br>Sets the bias of the analog signal input to MFAI terminal A2. | 0.0%<br>(-999.9 - +999.9%) |

When 0 V (4 mA or 0 mA) is input, this parameter sets the bias for the function set for terminal A2 as a percentage.

Use this parameter and *H3-11 [Terminal A2 Gain Setting]* to adjust the characteristics of the analog input signal to terminal A2.

### ■ H3-13: Analog Input FilterTime Constant

| No.<br>(Hex.)   | Name                             | Description   | Default<br>(Range)        |
|-----------------|----------------------------------|---|---------------------------|
| H3-13<br>(041B) | Analog Input FilterTime Constant | <b>V/f</b> <b>CL-V/f</b> <b>OLV</b> <b>CLV</b> <b>AOLV</b> <b>OLV/PM</b> <b>AOLV/PM</b> <b>CLV/PM</b> <b>EZOLV</b><br>Sets the time constant for primary delay filters on MFAI terminals. | 0.03 s<br>(0.00 - 2.00 s) |

Apply the primary delay filter to the analog input to enable an analog input signal without the use of high-frequency noise components. An analog input filter prevents irregular drive control. Drive operation becomes more stable as the programmed time becomes longer, but it also becomes less responsive to quickly changing analog signals.

### ■ H3-14: Analog Input Terminal Enable Sel

| No.<br>(Hex.)   | Name                             | Description   | Default<br>(Range) |
|-----------------|----------------------------------|---|--------------------|
| H3-14<br>(041C) | Analog Input Terminal Enable Sel | <b>V/f</b> <b>CL-V/f</b> <b>OLV</b> <b>CLV</b> <b>AOLV</b> <b>OLV/PM</b> <b>AOLV/PM</b> <b>CLV/PM</b> <b>EZOLV</b><br>Sets the enabled terminal or terminals when $H1-xx = C$ [ <i>MFDI Function Select = Analog Terminal Enable Selection</i> ] is ON. | 7<br>(1 - 7)       |

Input signals do not have an effect on terminals not set as targets.

**1 : Terminal A1 only**

**2 : Terminal A2 only**

**3 : Terminals A1 and A2**

**4 : Terminal A3 only**

**5 : Terminals A1 and A3**

**6 : Terminals A2 and A3**

**7 : Terminals A1, A2, and A3**

**Note:**

- The ON/OFF operation of terminal  $S_x$  set in *Analog Terminal Input Selection* [ $H1-xx = C$ ] has an effect on only the analog input terminal selected with *H3-14*.
- When  $H1-xx \neq C$ , the functions set to terminals A1 to A3 are always enabled.



### ■ H3-16: Terminal A1 Offset

| No. (Hex.)   | Name               | Description   | Default (Range)    |
|--------------|--------------------|---|--------------------|
| H3-16 (02F0) | Terminal A1 Offset | <div style="display: flex; justify-content: space-between; gap: 5px;"> <span>V/f</span> <span>CL-V/f</span> <span>OLV</span> <span>CLV</span> <span>AOLV</span> <span>OLV/PM</span> <span>AOLV/PM</span> <span>CLV/PM</span> <span>EZOLV</span> </div> Sets the offset level for analog signals input to terminal A1. Usually it is not necessary to change this setting. | 0<br>(-500 - +500) |

Adds the offset value for the analog input value. For voltage input, this parameter will set the offset when a signal of 0 V is input. For current input, this parameter will set the offset when a signal of 4 mA [H3-01 = 2] or 0 mA [H3-01 = 3] is input.

### ■ H3-17: Terminal A2 Offset

| No. (Hex.)   | Name               | Description   | Default (Range)    |
|--------------|--------------------|---|--------------------|
| H3-17 (02F1) | Terminal A2 Offset | <div style="display: flex; justify-content: space-between; gap: 5px;"> <span>V/f</span> <span>CL-V/f</span> <span>OLV</span> <span>CLV</span> <span>AOLV</span> <span>OLV/PM</span> <span>AOLV/PM</span> <span>CLV/PM</span> <span>EZOLV</span> </div> Sets the offset level for analog signals input to terminal A2. Usually it is not necessary to change this setting. | 0<br>(-500 - +500) |

Adds the offset value for the analog input value. For voltage input, this parameter will set the offset when a signal of 0 V is input. For current input, this parameter will set the offset when a signal of 4 mA [H3-09 = 2] or 0 mA [H3-09 = 3] is input.

### ■ H3-18: Terminal A3 Offset

| No. (Hex.)   | Name               | Description   | Default (Range)    |
|--------------|--------------------|---|--------------------|
| H3-18 (02F2) | Terminal A3 Offset | <div style="display: flex; justify-content: space-between; gap: 5px;"> <span>V/f</span> <span>CL-V/f</span> <span>OLV</span> <span>CLV</span> <span>AOLV</span> <span>OLV/PM</span> <span>AOLV/PM</span> <span>CLV/PM</span> <span>EZOLV</span> </div> Sets the offset level for analog signals input to terminal A3. Usually it is not necessary to change this setting. | 0<br>(-500 - +500) |

Adds the offset value for the analog input value. For voltage input, this parameter will set the offset when a signal of 0 V is input. For current input, this parameter will set the offset when a signal of 4 mA [H3-05 = 2] or 0 mA [H3-05 = 3] is input.

### ■ H3-40: Mbus Reg 15C1h Input Function

| No. (Hex.)   | Name                          | Description   | Default (Range) |
|--------------|-------------------------------|---|-----------------|
| H3-40 (0B5C) | Mbus Reg 15C1h Input Function | <div style="display: flex; justify-content: space-between; gap: 5px;"> <span>V/f</span> <span>CL-V/f</span> <span>OLV</span> <span>CLV</span> <span>AOLV</span> <span>OLV/PM</span> <span>AOLV/PM</span> <span>CLV/PM</span> <span>EZOLV</span> </div> Sets the MEMOBUS AI1 function. | F<br>(4 - 2F)   |

You can use the MFAI function from MEMOBUS/Modbus communications. Use this parameter to set the function. Sets the input for the function in MEMOBUS/Modbus register 15C1.

Refer to H3-xx “MFAI Setting Values” for the setting values.

### ■ H3-41: Mbus Reg 15C2h Input Function

| No. (Hex.)   | Name                          | Description   | Default (Range) |
|--------------|-------------------------------|---|-----------------|
| H3-41 (0B5F) | Mbus Reg 15C2h Input Function | <div style="display: flex; justify-content: space-between; gap: 5px;"> <span>V/f</span> <span>CL-V/f</span> <span>OLV</span> <span>CLV</span> <span>AOLV</span> <span>OLV/PM</span> <span>AOLV/PM</span> <span>CLV/PM</span> <span>EZOLV</span> </div> Sets the MEMOBUS AI2 function. | F<br>(4 - 2F)   |

You can use the MFAI function from MEMOBUS/Modbus communications. Use this parameter to set the function. Sets the input for the function in MEMOBUS/Modbus register 15C2.

Refer to H3-xx “MFAI Setting Values” for the setting values.

■ **H3-42: Mbus Reg 15C3h Input Function**

| No. (Hex.)   | Name                          | Description  | Default (Range) |
|--------------|-------------------------------|--|-----------------|
| H3-42 (0B62) | Mbus Reg 15C3h Input Function | <b>V/f</b> <b>CL-V/f</b> <b>OLV</b> <b>CLV</b> <b>AOLV</b> <b>OLV/PM</b> <b>AOLV/PM</b> <b>CLV/PM</b> <b>EZOLV</b><br>Sets the MEMOBUS AI3 function. | F<br>(4 - 2F)   |

You can use the MFAI function from MEMOBUS/Modbus communications. Use this parameter to set the function. Sets the input for the function in MEMOBUS/Modbus register 15C3.

Refer to H3-xx “MFAI Setting Values” for the setting values.

■ **H3-43: Mbus Reg Inputs FilterTime Const**

| No. (Hex.)   | Name                             | Description  | Default (Range)           |
|--------------|----------------------------------|--|---------------------------|
| H3-43 (117F) | Mbus Reg Inputs FilterTime Const | <b>V/f</b> <b>CL-V/f</b> <b>OLV</b> <b>CLV</b> <b>AOLV</b> <b>OLV/PM</b> <b>AOLV/PM</b> <b>CLV/PM</b> <b>EZOLV</b><br>Sets the time constant to apply a primary delay filter to the MEMOBUS analog input terminal. | 0.00 s<br>(0.00 - 2.00 s) |

◆ **Multi-Function Analog Input Terminal Settings**

This section gives information about the functions set with *H3-02*, *H3-06*, and *H3-10*.

■ **0: Frequency Reference**

| Setting Value | Function            | Description   |
|---------------|---------------------|---|
| 0             | Frequency Reference | <b>V/f</b> <b>CL-V/f</b> <b>OLV</b> <b>CLV</b> <b>AOLV</b> <b>OLV/PM</b> <b>AOLV/PM</b> <b>CLV/PM</b> <b>EZOLV</b><br>The input value from the MFAI terminal set with this function becomes the master frequency reference. |

- You can copy the configuration to more than one of the analog input terminals A1 through A3. When you set more than one analog input terminal with the master frequency reference, the sum value becomes the frequency bias.
- If you use this function to set the analog input value as the master frequency reference, set  $b1-01 = 1$  [*Frequency Reference Selection 1 = Analog Input*]. This setting value is the default value for terminals A1 and A2.
- The frequency reference is the sum of the input values for terminals A1 and A2 when they are used at the same time. For example, when a 20% bias is input to terminal A2 while a frequency reference of 50% is input from terminal A1, the calculated frequency reference will be 70% of the maximum output frequency.

■ **1: Frequency Gain**

| Setting Value | Function       | Description  |
|---------------|----------------|--|
| 1             | Frequency Gain | <b>V/f</b> <b>CL-V/f</b> <b>OLV</b> <b>CLV</b> <b>AOLV</b> <b>OLV/PM</b> <b>AOLV/PM</b> <b>CLV/PM</b> <b>EZOLV</b><br>The drive multiplies the analog frequency reference with the input value from the MFAI set with this function. |

Example: When you set frequency gain for terminal A2

- $H3-10 = 1$  [*Terminal A2 Function Selection = Frequency Gain*]
- A 50% frequency gain is input to terminal A2
- A frequency reference of 80% is input from terminal A1

The calculated frequency reference is 40% of the maximum output frequency.

■ **2: Auxiliary Frequency Reference 1**

| Setting Value | Function                        | Description  |
|---------------|---------------------------------|--|
| 2             | Auxiliary Frequency Reference 1 | <b>V/f</b> <b>CL-V/f</b> <b>OLV</b> <b>CLV</b> <b>AOLV</b> <b>OLV/PM</b> <b>AOLV/PM</b> <b>CLV/PM</b> <b>EZOLV</b><br>Sets Reference 2 through multi-step speed reference to enable the command reference (Auxiliary Frequency Reference 1) from the analog input terminal set here. This value is a percentage where the maximum output frequency setting is a setting value of 100%. |

### 3: Auxiliary Frequency Reference 2

| Setting Value | Function                        | Description   |
|---------------|---------------------------------|---|
| 3             | Auxiliary Frequency Reference 2 | <div style="display: flex; justify-content: space-between; align-items: center;"> <span>V/f</span> <span>CL-V/f</span> <span>OLV</span> <span>CLV</span> <span>AOLV</span> <span>OLV/PM</span> <span>AOLV/PM</span> <span>CLV/PM</span> <span>EZOLV</span> </div> <p>Sets Reference 3 through multi-step speed reference to enable the command reference (Auxiliary Frequency Reference 2) from the analog input terminal set here. This value is a percentage where Maximum Output Frequency setting is a setting value of 100%.</p> |

### 4: Output Voltage Bias

| Setting Value | Function            | Description  |
|---------------|---------------------|--|
| 4             | Output Voltage Bias | <div style="display: flex; justify-content: space-between; align-items: center;"> <span>V/f</span> <span>CL-V/f</span> <span>OLV</span> <span>CLV</span> <span>AOLV</span> <span>OLV/PM</span> <span>AOLV/PM</span> <span>CLV/PM</span> <span>EZOLV</span> </div> <p>Set this parameter to input a bias signal and amplify the output voltage.</p> |

The gain (%) for the MFAI terminals A1, A2, and A3 is 100% of the voltage class standard, which is 200 V for 200 V class drives and 400 V for 400 V class drives. The bias (%) for MFAI terminals A1, A2, and A3 is 100% of the voltage configured for E1-05 [Maximum Output Voltage].

**Note:**

The gain for each terminal A1, A2, and A3 is configured independently with H3-03 [Terminal A1 Gain Setting], H3-11 [Terminal A2 Gain Setting], and H3-07 [Terminal A3 Gain Setting]. The bias for each terminal A1, A2, and A3 is configured independently with H3-04 [Terminal A1 Bias Setting], H3-12 [Terminal A2 Bias Setting], and H3-08 [Terminal A3 Bias Setting].

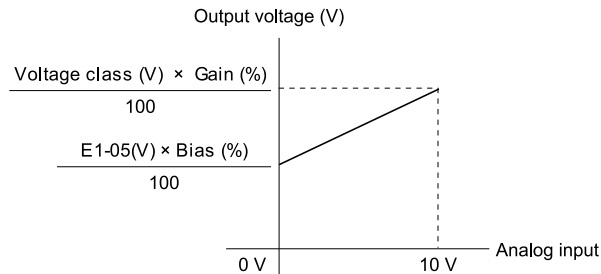


Figure 2.104 Output Voltage Bias through Analog Input

### 5: Accel/Decel Time Gain

| Setting Value | Function              | Description   |
|---------------|-----------------------|---|
| 5             | Accel/Decel Time Gain | <div style="display: flex; justify-content: space-between; align-items: center;"> <span>V/f</span> <span>CL-V/f</span> <span>OLV</span> <span>CLV</span> <span>AOLV</span> <span>OLV/PM</span> <span>AOLV/PM</span> <span>CLV/PM</span> <span>EZOLV</span> </div> <p>Enters a signal to adjust the gain used for C1-01 to C1-08 [Accel &amp; Decel Time 1 to 4] and C1-09 [Fast Stop Time] if the full scale analog signal (10 V or 20 mA) is 100%.</p> |

When you enable C1-01 [Acceleration Time 1], the acceleration time is:

$$\text{Acceleration Time 1} = \text{Setting value of C1-01} \times \text{acceleration and deceleration time gain} / 100$$

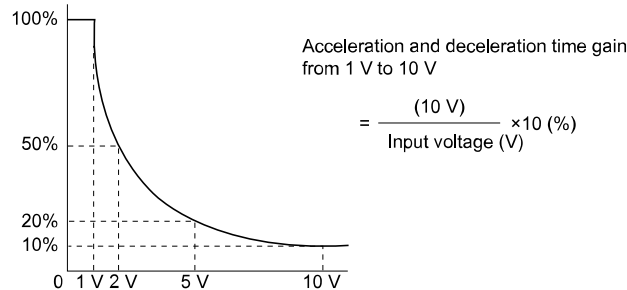


Figure 2.105 Acceleration/Deceleration Time Gain through Analog Input

### 6: DC Injection Braking Current

| Setting Value | Function                     | Description   |
|---------------|------------------------------|---|
| 6             | DC Injection Braking Current | <div style="display: flex; justify-content: space-between; align-items: center;"> <span>V/f</span> <span>CL-V/f</span> <span>OLV</span> <span>CLV</span> <span>AOLV</span> <span>OLV/PM</span> <span>AOLV/PM</span> <span>CLV/PM</span> <span>EZOLV</span> </div> <p>Enters a signal to adjust the current level used for DC Injection Braking if the drive rated output current is 100%.</p> |

Parameter Details

## 2.8 H: Terminal Functions

### Note:

When you set this function, it will disable the setting value of *b2-02 [DC Injection Braking Current]*.

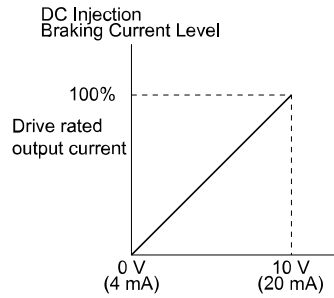


Figure 2.106 DC Injection Braking Current through Analog Input

### 7: Torque Detection Level

| Setting Value | Function               | Description   |
|---------------|------------------------|---|
| 7             | Torque Detection Level | <span>V/f</span> <span>CL-V/f</span> <span>OLV</span> <span>CLV</span> <span>AOLV</span> <span>OLV/PM</span> <span>AOLV/PM</span> <span>CLV/PM</span> <span>EZOLV</span><br>Enters a signal to adjust the overtorque/undertorque detection level. |

When *A1-02 = 0, 1, 5 [Control Method Selection = V/f, CL-V/f, OLV/PM]*, the drive rated current is 100%. When *A1-02 = 2, 3, 4, 6, 7, 8 [OLV, CLV, AOLV, AOLV/PM, CLV/PM, EZOLV]*, the motor rated torque is 100%.

### Note:

Use this function with *L6-01 [Torque Detection Selection 1]*. This parameter functions as an alternative to *L6-02 [Torque Detection Level 1]*.

### 8: Stall Prevent Level during Run

| Setting Value | Function                       | Description   |
|---------------|--------------------------------|---|
| 8             | Stall Prevent Level during Run | <span>V/f</span> <span>CL-V/f</span> <span>OLV</span> <span>CLV</span> <span>AOLV</span> <span>OLV/PM</span> <span>AOLV/PM</span> <span>CLV/PM</span> <span>EZOLV</span><br>Enters a signal to adjust the stall prevention level during run if the drive rated current is 100%. |

### Note:

The Stall Prevent Level During Run is based on either of the following values, whichever is smaller.

- Analog input value of MFA1 terminal
- *L3-06 [Stall Prevent Level during Run]*

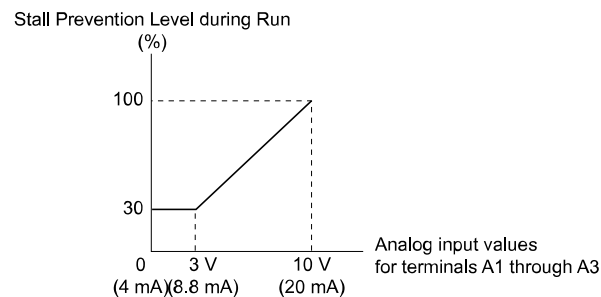


Figure 2.107 Stall Prevention Level during Run with Analog Input

### 9: Output Frequency Lower Limit

| Setting Value | Function                     | Description   |
|---------------|------------------------------|---|
| 9             | Output Frequency Lower Limit | <span>V/f</span> <span>CL-V/f</span> <span>OLV</span> <span>CLV</span> <span>AOLV</span> <span>OLV/PM</span> <span>AOLV/PM</span> <span>CLV/PM</span> <span>EZOLV</span><br>Enters a signal to adjust the output frequency lower limit level as a percentage of the maximum output frequency. |

### B: PID Feedback

| Setting Value | Function     | Description   |
|---------------|--------------|---|
| B             | PID Feedback | <span>V/f</span> <span>CL-V/f</span> <span>OLV</span> <span>CLV</span> <span>AOLV</span> <span>OLV/PM</span> <span>AOLV/PM</span> <span>CLV/PM</span> <span>EZOLV</span><br>Enter the PID feedback value as a percentage of the maximum output frequency. |

When you use this function, set  $b5-01 = 1$  to  $8$  [*PID Function Setting = Enabled*].

### ■ C: PID Setpoint

| Setting Value | Function     | Description  |
|---------------|--------------|--|
| C             | PID Setpoint | <b>V/f</b> <b>CL-V/f</b> <b>OLV</b> <b>CLV</b> <b>AOLV</b> <b>OLV/PM</b> <b>AOLV/PM</b> <b>CLV/PM</b> <b>EZOLV</b><br>Enters the PID setpoint as a percentage of the maximum output frequency. |

When you use this function, set  $b5-01 = 1$  to  $8$  [*PID Function Setting = Enabled*].

**Note:**

Configuring this function disables the frequency reference set with  $b1-01$  [*Frequency Reference Selection 1*].

### ■ D: Frequency Bias

| Setting Value | Function       | Description   |
|---------------|----------------|---|
| D             | Frequency Bias | <b>V/f</b> <b>CL-V/f</b> <b>OLV</b> <b>CLV</b> <b>AOLV</b> <b>OLV/PM</b> <b>AOLV/PM</b> <b>CLV/PM</b> <b>EZOLV</b><br>Enters the bias value added to the frequency reference as a percentage of the maximum output frequency. |

The drive adds the input value from the MFAI terminal set with this function to the frequency reference as the bias value.

**Note:**

If you select  $d1-01$  to  $d1-16$  or  $d1-17$  [*Frequency Reference 1 to 16 or JOG Frequency Reference*] as the frequency reference, it will disable this function.

### ■ E: Motor Temperature (PTC Input)

| Setting Value | Function                      | Description   |
|---------------|-------------------------------|---|
| E             | Motor Temperature (PTC Input) | <b>V/f</b> <b>CL-V/f</b> <b>OLV</b> <b>CLV</b> <b>AOLV</b> <b>OLV/PM</b> <b>AOLV/PM</b> <b>CLV/PM</b> <b>EZOLV</b><br>Uses the motor Positive Temperature Coefficient (PTC) thermistor to prevent heat damage to the motor as a percentage of the current value when the 10 V analog signal is input. |

- You can use the Positive Temperature Coefficient (PLC) thermistor as an auxiliary or alternative detection function for  $oL1$  [*Motor Overload*] problems to help prevent heat damage to motors. If the PTC input signal is more than the overload alarm level,  $oH3$  [*Motor Overheat (PTC Input)*] will flash on the keypad.
- When the drive detects  $oH3$ , the motor stops with the setting in  $L1-03$ . When the drive detects  $oH4$ , the motor stops with the setting in  $L1-04$ . When the drive incorrectly detects motor overheating problems, set  $L1-05$ .

### ■ F: Not Used

| Setting Value | Function | Description  |
|---------------|----------|--|
| F             | Not Used | <b>V/f</b> <b>CL-V/f</b> <b>OLV</b> <b>CLV</b> <b>AOLV</b> <b>OLV/PM</b> <b>AOLV/PM</b> <b>CLV/PM</b> <b>EZOLV</b><br>Use this setting for unused terminals or to use terminals in through mode. |

When you set a terminal that is not in use to F, you can use the signal input to the terminal as PLC analog signal input through MEMOBUS/Modbus communications or the communication option. This input signal does not have an effect on drive operation. This functions the same as setting 1F (Through Mode).

### ■ 10: Forward Torque Limit

| Setting Value | Function             | Description  |
|---------------|----------------------|--|
| 10            | Forward Torque Limit | <b>V/f</b> <b>CL-V/f</b> <b>OLV</b> <b>CLV</b> <b>AOLV</b> <b>OLV/PM</b> <b>AOLV/PM</b> <b>CLV/PM</b> <b>EZOLV</b><br>Enters the forward torque limit if the motor rated torque is 100%. |

**WARNING!** Sudden Movement Hazard. Set correct torque limits for applications, for example elevator applications. If you set torque limits incorrectly, motor torque that is not sufficient can cause damage to equipment and cause serious injury or death.

#### Torque Limit Configuration Method

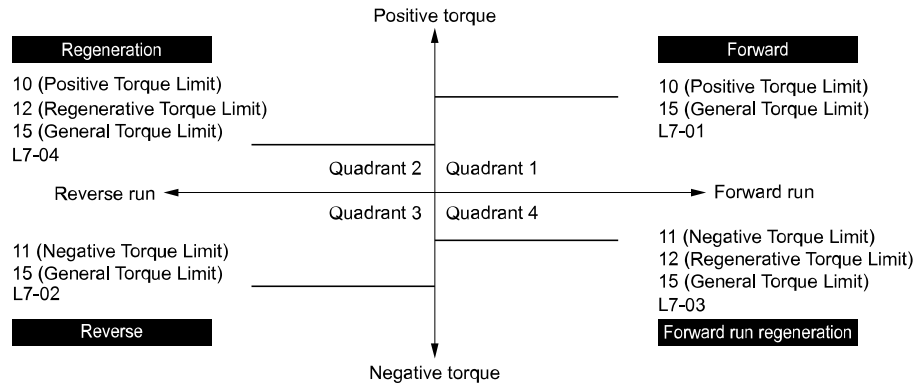
Use one of these methods to set torque limits:

- Individually set the four torque limit quadrants using  $L7-01$  to  $L7-04$  [*Torque Limit*].
- Use MFAI to individually set the four torque limit quadrants. Set  $H3-02$ ,  $H3-06$ ,  $H3-10 = 10$ ,  $11$ ,  $12$  [*MFAI Function Select = Forward/Reverse/Regenerative Torque Limit*].
- Use MFAI to set all four torque limit quadrants together. Set  $H3-02$ ,  $H3-06$ ,  $H3-10 = 15$  [*General Torque Limit*].

## 2.8 H: Terminal Functions

- Use a communication option to set all four torque limit quadrants together.

Figure 2.108 shows the configuration method for each quadrant.



**Figure 2.108 Torque Limits and Analog Input Setting Parameters**

**Note:**

- When L7-01 to L7-04 and analog inputs or communication option torque limits set torque limits for the same quadrant, the lower value is enabled.

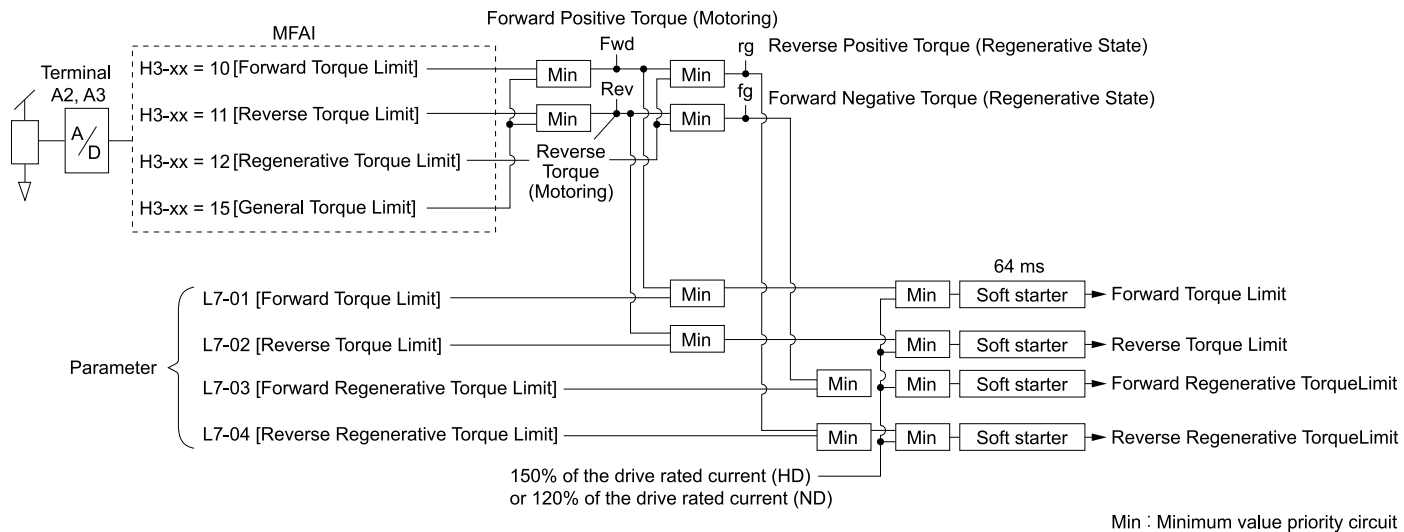
In this example of parameter settings, the torque limit for quadrant 1 is 130% and the torque limit for quadrants 2, 3, and 4 is 150%.  
Settings: L7-01 = 130%, L7-02 to L7-04 = 200%, and MFAI torque limit = 150%

- The drive output current limits maximum output torque. The torque limit is 150% of the rated output current for HD and to 120% of the rated output current for ND. The actual output torque is not more than the limits of the drive rated output current when you set the torque limit to a high value.

If you use drives in applications where the vertical axis can fall, make sure that you know these items:

- Correctly configure drives and motors.
- Correctly set parameters.
- You can change parameter values after you do Auto-Tuning.
- Use a system that will not let the vertical axis fall if the drive fails.

Figure 2.109 shows the relation between torque limits from parameters and torque limits from analog input.



**Figure 2.109 Torque Limits from Parameters and Analog Inputs**

### 11: Reverse Torque Limit

| Setting Value | Function             | Description  |
|---------------|----------------------|--|
| 11            | Reverse Torque Limit | V/f CL-V/f OLV CLV AOLV OLV/PM AOLV/PM CLV/PM EZOLV<br>Enters the load torque limit if the motor rated torque is 100%. |

**Note:**

When you use L7-01 to L7-04 and analog inputs to set torque limits for the same quadrant, it will enable the lower torque limit.

## ■ 12: Regenerative Torque Limit

| Setting Value | Function                  | Description  |
|---------------|---------------------------|--|
| 12            | Regenerative Torque Limit | V/f CL-V/f OLV CLV AOLV OLV/PM AOLV/PM CLV/PM EZOLV<br>Enters the regenerative torque limit if the motor rated torque is 100%. |

### Note:

When you use L7-01 to L7-04 and analog inputs to set torque limits for the same quadrant, it will enable the lower torque limit.

## ■ 13: Torque Reference / Torque Limit

| Setting Value | Function                        | Description   |
|---------------|---------------------------------|---|
| 13            | Torque Reference / Torque Limit | V/f CL-V/f OLV CLV AOLV OLV/PM AOLV/PM CLV/PM EZOLV<br>Enters the torque reference if the motor rated torque is 100%. This setting is the torque limit for speed control. |

### Note:

When you use L7-01 to L7-04 and analog inputs to set torque limits for the same quadrant, it will enable the lower torque limit.

## ■ 14: Torque Compensation

| Setting Value | Function            | Description  |
|---------------|---------------------|--|
| 14            | Torque Compensation | V/f CL-V/f OLV CLV AOLV OLV/PM AOLV/PM CLV/PM EZOLV<br>Enters the torque compensation value if the motor rated torque is 100%. |

## ■ 15: General Torque Limit

| Setting Value | Function             | Description   |
|---------------|----------------------|---|
| 15            | General Torque Limit | V/f CL-V/f OLV CLV AOLV OLV/PM AOLV/PM CLV/PM EZOLV<br>Enters the torque limit that is the same for all quadrants for forward, reverse, and regenerative operation if the motor rated torque is 100%. |

## ■ 16: Differential PID Feedback

| Setting Value | Function             | Description  |
|---------------|----------------------|--|
| 16            | PID DifferentialFdbk | V/f CL-V/f OLV CLV AOLV OLV/PM AOLV/PM CLV/PM EZOLV<br>Enters the PID differential feedback value if the full scale analog signal (10 V or 20 mA) is 100%. |

The drive uses the deviation between the PID feedback and the differential feedback value signals to calculate the PID input.

## ■ 1F: Not Used

| Setting Value | Function | Description   |
|---------------|----------|---|
| 1F            | Not Used | V/f CL-V/f OLV CLV AOLV OLV/PM AOLV/PM CLV/PM EZOLV<br>Use this setting for unused terminals or to use terminals in through mode. |

When you set a terminal that you do not use to 1F, you can use the signal that is input to that terminal as the PLC analog signal input from MEMOBUS/Modbus communications or the communication option. This input signal does not have an effect on drive operation. This signal functions the same as F (Through Mode).

## ■ 30: DWEZ Analog Input 1

| Setting Value | Function            | Description   |
|---------------|---------------------|---|
| 30            | DWEZ Analog Input 1 | V/f CL-V/f OLV CLV AOLV OLV/PM AOLV/PM CLV/PM EZOLV<br>Use with DriveWorksEZ. Refer to the DriveWorksEZ online manual for more information. |

## ■ 31: DWEZ Analog Input 2

| Setting Value | Function            | Description   |
|---------------|---------------------|---|
| 31            | DWEZ Analog Input 2 | V/f CL-V/f OLV CLV AOLV OLV/PM AOLV/PM CLV/PM EZOLV<br>Use with DriveWorksEZ. Refer to the DriveWorksEZ online manual for more information. |

■ 32: DWEZ Analog Input 3

| Setting Value | Function            | Description  |
|---------------|---------------------|--|
| 32            | DWEZ Analog Input 3 | <div style="display: flex; gap: 5px;"> <span>V/f</span> <span>CL-V/f</span> <span>OLV</span> <span>CLV</span> <span>AOLV</span> <span>OLV/PM</span> <span>AOLV/PM</span> <span>CLV/PM</span> <span>EZOLV</span> </div> <p>Use with DriveWorksEZ. Refer to the DriveWorksEZ online manual for more information.</p> |

◆ H4: Analog Outputs

H4 parameters set the drive analog monitors. These parameters select monitor parameters, adjust gain and bias, and select output signal levels.

■ Calibrate Meters Connected to MFAO Terminals FM and AM

To calibrate the meters connected to terminals FM and AM, use these parameters:

- H4-02 [Terminal FM Analog Output Gain]
- H4-03 [Terminal FM Analog Output Bias]
- H4-05 [Terminal AM Analog Output Gain]
- H4-06 [Terminal AM Analog Output Bias]

Set these parameters on the assumption that output voltage of 10 V and output current of 20 mA represent 100% of the signal level. Select the voltage output and current output with jumper switch S5 and H4-07 [Terminal FM Signal Level Select] or H4-08 [Terminal AM Signal Level Select].

| No.   | Name                            | Range  | Default |
|-------|---------------------------------|--|---------|
| H4-02 | Terminal FM Analog Output Gain  | -999.9 - +999.9%                             | 100.0%  |
| H4-03 | Terminal FM Analog Output Bias  | -999.9 - +999.9%                             | 0.0%    |
| H4-05 | Terminal AM Analog Output Gain  | -999.9 - +999.9%                             | 50.0%   |
| H4-06 | Terminal AM Analog Output Bias  | -999.9 - +999.9%                             | 0.0%    |
| H4-07 | Terminal FM Signal Level Select | 0: 0 +10 VDC<br>1: -10 +10 VDC<br>2: 4-20 mA | 0       |
| H4-08 | Terminal AM Signal Level Select | 0: 0 +10 VDC<br>1: -10 +10 VDC<br>2: 4-20 mA | 0       |

Figure 2.110 and Figure 2.111 show the gain and bias.

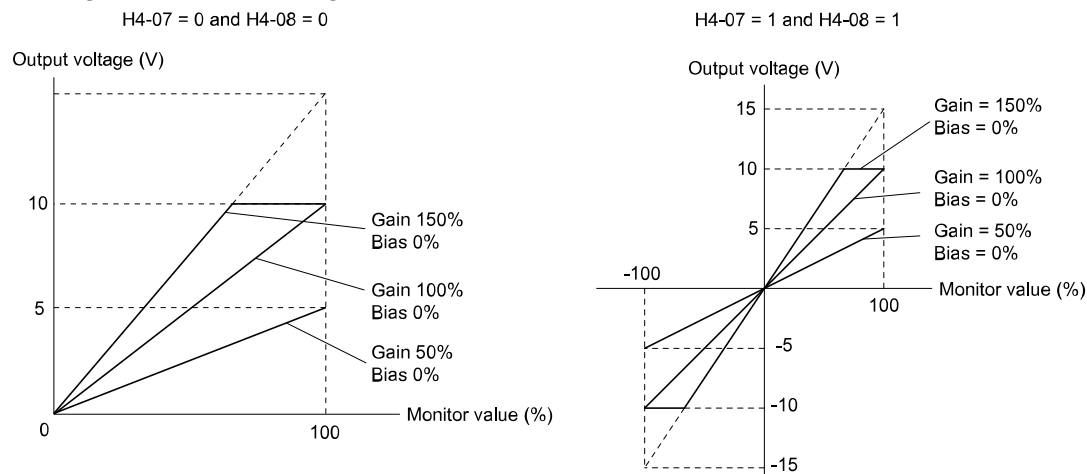


Figure 2.110 Analog Output Gain/Bias Configuration Example 1

For example, when the parameter value set to analog output is 0, and a 3 V signal is output to terminal FM, H4-03 [Terminal FM Analog Output Bias] is set to 30%.



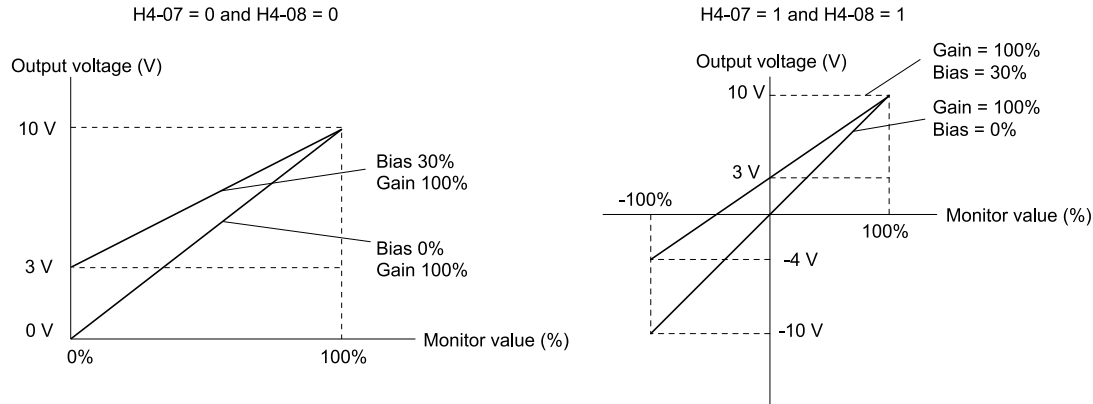


Figure 2.111 Analog Output Gain/Bias Configuration Example 2

**Calibrate Terminal FM**

Stop the drive to calibrate meters. Use this procedure to calibrate:

1. Show *H4-02 [Terminal FM Analog Output Gain]* on the keypad. Terminal FM outputs the analog signal when the monitor item that you set in *H4-01 [Terminal FM Analog Output Select]* is 100%.
2. Adjust *H4-02* while referencing the meter scale connected to terminal FM.
3. Show *H4-03 [Terminal FM Analog Output Bias]* on the keypad. The analog signal at the time when the monitor item selected with *H4-01* is 0% is output from terminal FM.
4. Adjust *H4-03* while referencing the meter scale connected to terminal FM.

**Calibrate Terminal AM**

Stop the drive to calibrate meters. Use this procedure to calibrate:

1. Show *H4-05 [Terminal AM Analog Output Gain]* on the keypad. Terminal AM outputs the analog signal when the monitor item that you set in *H4-04 [Terminal AM Analog Output Select]* is 100%.
2. Adjust *H4-05* and monitor the meter scale connected to terminal AM.
3. Show *H4-06 [Terminal AM Analog Output Bias]* on the keypad. Terminal AM outputs the analog signal when the monitor item that you set in *H4-04 [Terminal AM Analog Output Select]* is 0%.
4. Adjust *H4-06* while referencing the meter scale connected to terminal AM.

■ **H4-01: Terminal FM Analog Output Select**

| No. (Hex.)   | Name                             | Description  | Default (Range)    |
|--------------|----------------------------------|--|--------------------|
| H4-01 (041D) | Terminal FM Analog Output Select | <b>V/f</b> <b>CL-V/f</b> <b>OLV</b> <b>CLV</b> <b>AOLV</b> <b>OLV/PM</b> <b>AOLV/PM</b> <b>CLV/PM</b> <b>EZOLV</b><br>Sets the monitor number to send from MFAO terminal FM. | 102<br>(000 - 999) |

Set the *x-xx* part of the *Ux-xx [Monitor]*. For example, set *H4-01 = 102* to monitor *U1-02 [Output Frequency]*.

**Note:**

- You cannot use all of the monitors in all of the control methods.
- When you use the terminal in through mode, set this parameter to *000* or *031*. You can set the terminal FM output level from the PLC through MEMOBUS/Modbus communications or the communication option.

■ **H4-02: Terminal FM Analog Output Gain**

| No. (Hex.)       | Name                           | Description   | Default (Range)              |
|------------------|--------------------------------|---|------------------------------|
| H4-02 (041E) RUN | Terminal FM Analog Output Gain | <b>V/f</b> <b>CL-V/f</b> <b>OLV</b> <b>CLV</b> <b>AOLV</b> <b>OLV/PM</b> <b>AOLV/PM</b> <b>CLV/PM</b> <b>EZOLV</b><br>Sets the gain of the monitor signal that is sent from MFAO terminal FM. | 100.0%<br>(-999.9 - +999.9%) |

The analog signal output from the FM terminal is a maximum of  $\pm 10$  V (or 20 mA). Select the signal level with *H4-07 [Terminal FM Signal Level Select]*.

## 2.8 H: Terminal Functions

### ■ H4-03: Terminal FM Analog Output Bias

| No. (Hex.)             | Name                           | Description   | Default (Range)            |
|------------------------|--------------------------------|---|----------------------------|
| H4-03<br>(041F)<br>RUN | Terminal FM Analog Output Bias | <b>V/f</b> <b>CL-V/f</b> <b>OLV</b> <b>CLV</b> <b>AOLV</b> <b>OLV/PM</b> <b>AOLV/PM</b> <b>CLV/PM</b> <b>EZOLV</b><br>Sets the bias of the monitor signal that is sent from MFAO terminal FM. | 0.0%<br>(-999.9 - +999.9%) |

The analog signal output from the FM terminal is a maximum of  $\pm 10$  V (or 20 mA). Select the signal level with *H4-07* [Terminal FM Signal Level Select].

### ■ H4-04: Terminal AM Analog Output Select

| No. (Hex.)      | Name                             | Description  | Default (Range)    |
|-----------------|----------------------------------|--|--------------------|
| H4-04<br>(0420) | Terminal AM Analog Output Select | <b>V/f</b> <b>CL-V/f</b> <b>OLV</b> <b>CLV</b> <b>AOLV</b> <b>OLV/PM</b> <b>AOLV/PM</b> <b>CLV/PM</b> <b>EZOLV</b><br>Sets the monitoring number to be output from the MFAO terminal AM. | 103<br>(000 - 999) |

Set the *x-xx* part of the *Ux-xx* [Monitor]. For example, set *H4-04 = 103* to monitor *U1-03* [Output Current].

**Note:**

- You cannot use all of the monitors in all of the control methods.
- When you use the terminal in through mode, set this parameter to *000* or *031*. You can set the terminal AM output level from the PLC through MEMOBUS/Modbus communications or the communication option.

### ■ H4-05: Terminal AM Analog Output Gain

| No. (Hex.)             | Name                           | Description   | Default (Range)             |
|------------------------|--------------------------------|---|-----------------------------|
| H4-05<br>(0421)<br>RUN | Terminal AM Analog Output Gain | <b>V/f</b> <b>CL-V/f</b> <b>OLV</b> <b>CLV</b> <b>AOLV</b> <b>OLV/PM</b> <b>AOLV/PM</b> <b>CLV/PM</b> <b>EZOLV</b><br>Sets the gain of the monitor signal that is sent from MFAO terminal AM. | 50.0%<br>(-999.9 - +999.9%) |

The analog signal output from the AM terminal is a maximum of  $\pm 10$  V (or 20 mA). Select the signal level with *H4-08* [Terminal AM Signal Level Select].

Examples of possible settings:

When the output current of a monitoring item is 100% (drive rated current) in these examples, the voltage of AM terminal outputs at 5 V (50% of 10 V). Subsequently, the output current at the time the AM terminal outputs a maximum voltage of 10 V will be 200% of the drive rated current.

- *H4-04 = 103* [Terminal AM Analog Output Select = Output Current]
- *H4-05 = 50.0%*
- *H4-06 = 0.0%* [Terminal AM Analog Output Bias = 0.0%]
- *H4-08 = 0* [0 to 10 V]

### ■ H4-06: Terminal AM Analog Output Bias

| No. (Hex.)             | Name                           | Description   | Default (Range)            |
|------------------------|--------------------------------|---|----------------------------|
| H4-06<br>(0422)<br>RUN | Terminal AM Analog Output Bias | <b>V/f</b> <b>CL-V/f</b> <b>OLV</b> <b>CLV</b> <b>AOLV</b> <b>OLV/PM</b> <b>AOLV/PM</b> <b>CLV/PM</b> <b>EZOLV</b><br>Sets the bias of the monitor signal that is sent from MFAO terminal AM. | 0.0%<br>(-999.9 - +999.9%) |

The analog signal output from the AM terminal is a maximum of  $\pm 10$  V (or 20 mA). Select the signal level with *H4-08* [Terminal AM Signal Level Select].

### ■ H4-07: Terminal FM Signal Level Select

| No. (Hex.)      | Name                            | Description  | Default (Range) |
|-----------------|---------------------------------|--|-----------------|
| H4-07<br>(0423) | Terminal FM Signal Level Select | <b>V/f</b> <b>CL-V/f</b> <b>OLV</b> <b>CLV</b> <b>AOLV</b> <b>OLV/PM</b> <b>AOLV/PM</b> <b>CLV/PM</b> <b>EZOLV</b><br>Sets the MFAO terminal FM output signal level. | 0<br>(0 - 2)    |

**Note:**

Set jumper S5 on the control circuit terminal block accordingly when changing these parameters.

**0 : 0-10 VDC**

**1 : -10 +10 VDC**

**2 : 4-20 mA**

### ■ H4-08: Terminal AM Signal Level Select

| No. (Hex.)   | Name                            | Description  | Default (Range) |
|--------------|---------------------------------|--|-----------------|
| H4-08 (0424) | Terminal AM Signal Level Select | <span>V/f</span> <span>CL-V/f</span> <span>OLV</span> <span>CLV</span> <span>AOLV</span> <span>OLV/PM</span> <span>AOLV/PM</span> <span>CLV/PM</span> <span>EZOLV</span><br>Sets the MFAO terminal AM output signal level. | 0<br>(0 - 2)    |

**Note:**

Set jumper S5 on the terminal board to the correct position after changing this parameter.

**0 : 0-10 VDC**

**1 : -10 +10 VDC**

**2 : 4-20 mA**

### ■ H4-20: Analog Power Monitor 100% Level

| No. (Hex.)   | Name                            | Description  | Default (Range)               |
|--------------|---------------------------------|--|-------------------------------|
| H4-20 (0B53) | Analog Power Monitor 100% Level | <span>V/f</span> <span>CL-V/f</span> <span>OLV</span> <span>CLV</span> <span>AOLV</span> <span>OLV/PM</span> <span>AOLV/PM</span> <span>CLV/PM</span> <span>EZOLV</span><br>Sets the level at 10 V when U1-08 [Output Power] is set for analog output. | 0.00 kW<br>(0.00 - 650.00 kW) |

**Note:**

• When H4-20 = 0.00 kW, the output power monitor 10 V level = motor rated power (kW). The setting changes when the A1-02 [Control Method Selection] value changes:

–A1-02 = 0, 1 [V/f, CL-V/f]: E2-11 [Motor Rated Power (kW)]

–A1-02 = 2, 3, 4 [OLV, CLV, AOLV]: E2-11 [Motor Rated Power (kW)]

–A1-02 = 5, 6, 7 [OLV/PM, AOLV/PM, CLV/PM]: E5-02 [PM Motor Rated Power (kW)]

–A1-02 = 8 [EZOLV]: E9-07 [Motor Rated Power (Kw)]

## ◆ H5: Memobus/Modbus Communication

H5 parameters configure the drive to use MEMOBUS/Modbus communications.

You can use the MEMOBUS/Modbus protocol over the RS-485 port (terminals D+ and D-) in the drive to use serial communication with programmable controllers (PLC).

### ■ H5-01: Drive Node Address

| No. (Hex.)   | Name          | Description  | Default (Range)  |
|--------------|---------------|--|------------------|
| H5-01 (0425) | Slave address | <span>V/f</span> <span>CL-V/f</span> <span>OLV</span> <span>CLV</span> <span>AOLV</span> <span>OLV/PM</span> <span>AOLV/PM</span> <span>CLV/PM</span> <span>EZOLV</span><br>Sets the communication slave address for drives. | 1FH<br>(0 - FFH) |

**Note:**

• Restart the drive after changing the parameter setting.

• Setting 0 will not let the drive respond to MEMOBUS/Modbus communications.

To enable the drive to communicate with the controller (master) over MEMOBUS/Modbus communications, you must set the drive with a slave address. Set H5-01 ≠ 0.

Set a slave address that is different from other slave devices.

## 2.8 H: Terminal Functions

### ■ H5-02: Communication Speed Selection

| No.<br>(Hex.)   | Name                          | Description   | Default<br>(Range) |
|-----------------|-------------------------------|---|--------------------|
| H5-02<br>(0426) | Communication Speed Selection | <div style="display: flex; gap: 5px;"> <span>V/f</span> <span>CL-V/f</span> <span>OLV</span> <span>CLV</span> <span>AOLV</span> <span>OLV/PM</span> <span>AOLV/PM</span> <span>CLV/PM</span> <span>EZOLV</span> </div> Sets the communications speed for MEMOBUS/Modbus communications. | 3<br>(0 - 8)       |

**Note:**

Restart the drive after you change the parameter setting.

- 0 : 1200 bps**
- 1 : 2400 bps**
- 2 : 4800 bps**
- 3 : 9600 bps**
- 4 : 19.2 kbps**
- 5 : 38.4 kbps**
- 6 : 57.6 kbps**
- 7 : 76.8 kbps**
- 8 : 115.2 kbps**

### ■ H5-03: Communication Parity Selection

| No.<br>(Hex.)   | Name                           | Description   | Default<br>(Range) |
|-----------------|--------------------------------|---|--------------------|
| H5-03<br>(0427) | Communication Parity Selection | <div style="display: flex; gap: 5px;"> <span>V/f</span> <span>CL-V/f</span> <span>OLV</span> <span>CLV</span> <span>AOLV</span> <span>OLV/PM</span> <span>AOLV/PM</span> <span>CLV/PM</span> <span>EZOLV</span> </div> Sets the communications parity used for MEMOBUS/Modbus communications. | 0<br>(0 - 2)       |

**Note:**

Restart the drive after you change the parameter setting.

- 0 : No parity**
- 1 : Even parity**
- 2 : Odd parity**

### ■ H5-04: Communication Error Stop Method

| No.<br>(Hex.)   | Name                            | Description   | Default<br>(Range) |
|-----------------|---------------------------------|---|--------------------|
| H5-04<br>(0428) | Communication Error Stop Method | <div style="display: flex; gap: 5px;"> <span>V/f</span> <span>CL-V/f</span> <span>OLV</span> <span>CLV</span> <span>AOLV</span> <span>OLV/PM</span> <span>AOLV/PM</span> <span>CLV/PM</span> <span>EZOLV</span> </div> Sets the motor Stopping Method when the drive detects <i>CE [MEMOBUS/Modbus Communication Err]</i> issues. | 3<br>(0 - 3)       |

#### 0 : Ramp to Stop

The drive ramps the motor to stop in the deceleration time. Fault relay output terminal MA-MC turns ON, and MB-MC turns OFF.

#### 1 : Coast to Stop

The output turns off and the motor coasts to stop. Fault relay output terminal MA-MC turns ON, and MB-MC turns OFF.

#### 2 : Fast Stop (Use C1-09)

The drive stops the motor in the deceleration time set in *C1-09 [Fast Stop Time]*. Fault relay output terminal MA-MC turns ON, and MB-MC turns OFF.

#### 3 : Alarm Only

The keypad shows *CE* and the drive continues operation. The output terminal set for *Alarm [H2-01 to H2-03 = 10]* activates.

■ **H5-05: Comm Fault Detection Selection**

| No. (Hex.)   | Name                           | Description  | Default (Range) |
|--------------|--------------------------------|--|-----------------|
| H5-05 (0429) | Comm Fault Detection Selection | <div style="display: flex; justify-content: space-between; gap: 5px;"> <span>V/f</span> <span>CL-V/f</span> <span>OLV</span> <span>CLV</span> <span>AOLV</span> <span>OLV/PM</span> <span>AOLV/PM</span> <span>CLV/PM</span> <span>EZOLV</span> </div> <p>Sets the function that detects <i>CE</i> [Modbus Communication Error] issues during MEMOBUS/Modbus communications.</p> | 1 (0, 1)        |

If the drive does not receive data from the master during the time set in *H5-09* [CE Detection Time], it will detect a *CE* error.

**0 : Disabled**

Does not detect *CE*. The drive continues operation.

**1 : Enabled**

Detects *CE*. If the drive detects *CE*, it will operate as specified by the setting of *H5-04* [Communication Error Stop Method].

■ **H5-06: Drive Transmit Wait Time**

| No. (Hex.)   | Name                     | Description  | Default (Range)  |
|--------------|--------------------------|--|------------------|
| H5-06 (042A) | Drive Transmit Wait Time | <div style="display: flex; justify-content: space-between; gap: 5px;"> <span>V/f</span> <span>CL-V/f</span> <span>OLV</span> <span>CLV</span> <span>AOLV</span> <span>OLV/PM</span> <span>AOLV/PM</span> <span>CLV/PM</span> <span>EZOLV</span> </div> <p>Sets the time to wait to send a response message after the drive receives a command message from the master.</p> | 5 ms (0 - 65 ms) |

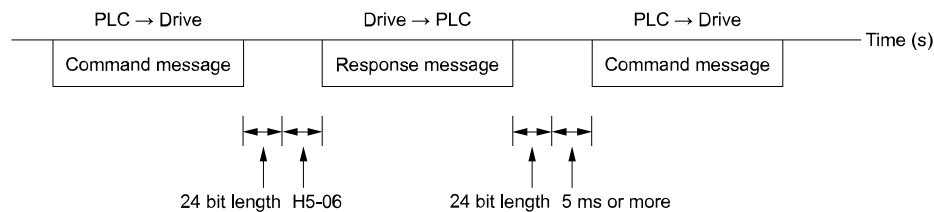


Figure 2.112 Drive Transmit Wait Time

■ **H5-09: CE Detection Time**

| No. (Hex.)   | Name              | Description   | Default (Range)      |
|--------------|-------------------|---|----------------------|
| H5-09 (0435) | CE Detection Time | <div style="display: flex; justify-content: space-between; gap: 5px;"> <span>V/f</span> <span>CL-V/f</span> <span>OLV</span> <span>CLV</span> <span>AOLV</span> <span>OLV/PM</span> <span>AOLV/PM</span> <span>CLV/PM</span> <span>EZOLV</span> </div> <p>Sets the detection time for <i>CE</i> [Modbus Communication Error] issues when communication stops.</p> | 2.0 s (0.0 - 10.0 s) |

■ **H5-10: Modbus Register 0025H Unit Sel**

| No. (Hex.)   | Name                           | Description  | Default (Range) |
|--------------|--------------------------------|--|-----------------|
| H5-10 (0436) | Modbus Register 0025H Unit Sel | <div style="display: flex; justify-content: space-between; gap: 5px;"> <span>V/f</span> <span>CL-V/f</span> <span>OLV</span> <span>CLV</span> <span>AOLV</span> <span>OLV/PM</span> <span>AOLV/PM</span> <span>CLV/PM</span> <span>EZOLV</span> </div> <p>Sets the unit of measure used for the MEMOBUS/Modbus communications monitor register 0025H (output voltage reference monitor).</p> | 0 (0, 1)        |

**0 : 0.1 V units**

**1 : 1 V units**

■ **H5-11: Comm ENTER Command Mode**

| No. (Hex.)   | Name                    | Description   | Default (Range) |
|--------------|-------------------------|---|-----------------|
| H5-11 (043C) | Comm ENTER Command Mode | <div style="display: flex; justify-content: space-between; gap: 5px;"> <span>V/f</span> <span>CL-V/f</span> <span>OLV</span> <span>CLV</span> <span>AOLV</span> <span>OLV/PM</span> <span>AOLV/PM</span> <span>CLV/PM</span> <span>EZOLV</span> </div> <p>Sets the function to make the Enter command necessary to change parameters through MEMOBUS/Modbus communications.</p> | 0 (0, 1)        |

**0 : ENTER Command Required**

Parameter Details

## 2.8 H: Terminal Functions

You must use the Enter command to enable changes to parameters. Make all parameter changes then input the Enter command.

### 1 : ENTER Command Not Required

It is not necessary to input the Enter command to change parameters.

#### ■ H5-12: Run Command Method Selection

| No. (Hex.)   | Name                         | Description   | Default (Range) |
|--------------|------------------------------|---|-----------------|
| H5-12 (043D) | Run Command Method Selection | <div style="display: flex; justify-content: space-between; align-items: center;"> <span>V/f</span> <span>CL-V/f</span> <span>OLV</span> <span>CLV</span> <span>AOLV</span> <span>OLV/PM</span> <span>AOLV/PM</span> <span>CLV/PM</span> <span>EZOLV</span> </div> <p>Sets the input method for the Run command when <math>b1-02 = 2</math> [Run Command Selection 1 = Memobus/Modbus Communications] or <math>b1-16 = 2</math> [Run Command Selection 2 = Memobus/Modbus Communications].</p> | 0<br>(0, 1)     |

#### 0 : FWD/Stop, REV/Stop

The drive uses bit 0 in command data 0001H of the MEMOBUS register in the motor forward Run command (bit 0 = 1) and the stop command (bit 0 = 0). The drive uses bit 1 in the motor reverse Run command (bit 1 = 1) and the stop command (bit 1 = 0).

#### 1 : Run/Stop, FWD/REV

The drive uses bit 0 in command data 0001H of the MEMOBUS register in the motor Run command (bit 0 = 1) and the stop command (bit 0 = 0). The drive uses bit 1 in the direction of motor rotation command (Forward run (bit1 = 0) or Reverse run (bit 1 = 1)).

#### ■ H5-17: ENTER command response @CPU BUSY

| No. (Hex.)             | Name                             | Description   | Default (Range) |
|------------------------|----------------------------------|---|-----------------|
| H5-17 (11A1)<br>Expert | ENTER command response @CPU BUSY | <div style="display: flex; justify-content: space-between; align-items: center;"> <span>V/f</span> <span>CL-V/f</span> <span>OLV</span> <span>CLV</span> <span>AOLV</span> <span>OLV/PM</span> <span>AOLV/PM</span> <span>CLV/PM</span> <span>EZOLV</span> </div> <p>Sets operation when the EEPROM write command is sent without EEPROM write available. Usually it is not necessary to change this setting.</p> | 0<br>(0, 1)     |

#### 0 : Ignore Command(No ROM/RAM Write)

#### 1 : Write to RAM Only

#### ■ H5-18: Motor Speed Filter over Comms

| No. (Hex.)   | Name                          | Description  | Default (Range)      |
|--------------|-------------------------------|--|----------------------|
| H5-18 (11A2) | Motor Speed Filter over Comms | <div style="display: flex; justify-content: space-between; align-items: center;"> <span>V/f</span> <span>CL-V/f</span> <span>OLV</span> <span>CLV</span> <span>AOLV</span> <span>OLV/PM</span> <span>AOLV/PM</span> <span>CLV/PM</span> <span>EZOLV</span> </div> <p>Sets the filter time constant used when monitoring motor speed during MEMOBUS/Modbus communications or with a communication option.</p> | 0 ms<br>(0 - 100 ms) |

Sets the filter time constant when you monitor the output frequency or motor speed during MEMOBUS/Modbus communications or use of the communication option.

These are the MEMOBUS registers:

- 003EH (Output Frequency)
- 003FH (Output Frequency)
- 0044H (UI-05: Motor Speed)
- 00ACH (UI-05: Motor Speed)
- 00ADH (UI-05: Motor Speed)

#### ■ H5-20: Communication Parameters Reload

| No. (Hex.)   | Name                            | Description  | Default (Range) |
|--------------|---------------------------------|--|-----------------|
| H5-20 (0B57) | Communication Parameters Reload | <div style="display: flex; justify-content: space-between; align-items: center;"> <span>V/f</span> <span>CL-V/f</span> <span>OLV</span> <span>CLV</span> <span>AOLV</span> <span>OLV/PM</span> <span>AOLV/PM</span> <span>CLV/PM</span> <span>EZOLV</span> </div> <p>Sets the function to immediately enable updated MEMOBUS/Modbus communications parameters.</p> | 0<br>(0, 1)     |

#### 0 : Reload at Next Power Cycle

#### 1 : Reload Now

**Note:**

- The setting value automatically returns to  $H5-20 = 0$  after you enable MEMOBUS/Modbus communications parameter changes.
- The setting values of these parameters are enabled:
  - H5-01 [Drive Node Address]
  - H5-02 [Communication Speed Selection]
  - H5-03 [Communication Parity Selection]
  - H5-06 [Drive Transmit Wait Time]

**■ H5-22: Speed Search from MEMOBUS**

| No.<br>(Hex.)   | Name                      | Description  | Default<br>(Range) |
|-----------------|---------------------------|--|--------------------|
| H5-22<br>(11CF) | Speed Search from MEMOBUS | <b>V/f</b> <b>CL-V/f</b> <b>OLV</b> <b>CLV</b> <b>AOLV</b> <b>OLV/PM</b> <b>AOLV/PM</b> <b>CLV/PM</b> <b>EZOLV</b><br>Enables the MEMOBUS/Modbus communication register Speed Search function (bit0 of 15DFH). | 0<br>(0, 1)        |

**0 : No****1 : Yes**

The drive will detect *oPE03 [Multi-Function Input Setting Err]* when you set  $H5-22 = 1$  and  $H1-xx = 62$  [Speed Search from Fref] at the same time.

**■ H5-25: Function 5A Register 1 Selection**

| No.<br>(Hex.)          | Name                             | Description  | Default<br>(Range)               |
|------------------------|----------------------------------|--|----------------------------------|
| H5-25<br>(1589)<br>RUN | Function 5A Register 1 Selection | <b>V/f</b> <b>CL-V/f</b> <b>OLV</b> <b>CLV</b> <b>AOLV</b> <b>OLV/PM</b> <b>AOLV/PM</b> <b>CLV/PM</b> <b>EZOLV</b><br>Returns the contents of the specified MEMOBUS/Modbus communications register when responding to the master device. | 0044H (U1-05)<br>(0000H - FFFFH) |

**■ H5-26: Function 5A Register 2 Selection**

| No.<br>(Hex.)          | Name                             | Description  | Default<br>(Range)               |
|------------------------|----------------------------------|--|----------------------------------|
| H5-26<br>(158A)<br>RUN | Function 5A Register 2 Selection | <b>V/f</b> <b>CL-V/f</b> <b>OLV</b> <b>CLV</b> <b>AOLV</b> <b>OLV/PM</b> <b>AOLV/PM</b> <b>CLV/PM</b> <b>EZOLV</b><br>Returns the contents of the specified MEMOBUS/Modbus communications register when responding to the master device. | 0045H (U1-06)<br>(0000H - FFFFH) |

**■ H5-27: Function 5A Register 3 Selection**

| No.<br>(Hex.)          | Name                             | Description  | Default<br>(Range)               |
|------------------------|----------------------------------|--|----------------------------------|
| H5-27<br>(158B)<br>RUN | Function 5A Register 3 Selection | <b>V/f</b> <b>CL-V/f</b> <b>OLV</b> <b>CLV</b> <b>AOLV</b> <b>OLV/PM</b> <b>AOLV/PM</b> <b>CLV/PM</b> <b>EZOLV</b><br>Returns the contents of the specified MEMOBUS/Modbus communications register when responding to the master device. | 0042H (U1-03)<br>(0000H - FFFFH) |

**■ H5-28: Function 5A Register 4 Selection**

| No.<br>(Hex.)          | Name                             | Description  | Default<br>(Range)               |
|------------------------|----------------------------------|--|----------------------------------|
| H5-28<br>(158C)<br>RUN | Function 5A Register 4 Selection | <b>V/f</b> <b>CL-V/f</b> <b>OLV</b> <b>CLV</b> <b>AOLV</b> <b>OLV/PM</b> <b>AOLV/PM</b> <b>CLV/PM</b> <b>EZOLV</b><br>Returns the contents of the specified MEMOBUS/Modbus communications register when responding to the master device. | 0049H (U1-10)<br>(0000H - FFFFH) |

**◆ H6: Pulse Train Input/Output**

*H6 parameters* set the drive pulse train input and pulse train monitor. These parameters select input and monitor parameters and adjust the pulse train frequency.

A pulse train signal with a maximum single pulse of 32 kHz can be input to the drive input terminal RP. You can use the pulse train signal as the frequency reference, PID feedback value, PID setpoint value, and speed feedback for V/f Control mode.

## 2.8 H: Terminal Functions

A pulse train signal with a maximum frequency of 32 kHz can be output from the drive output terminal MP as the monitor value. Sinking mode and sourcing mode are supported.

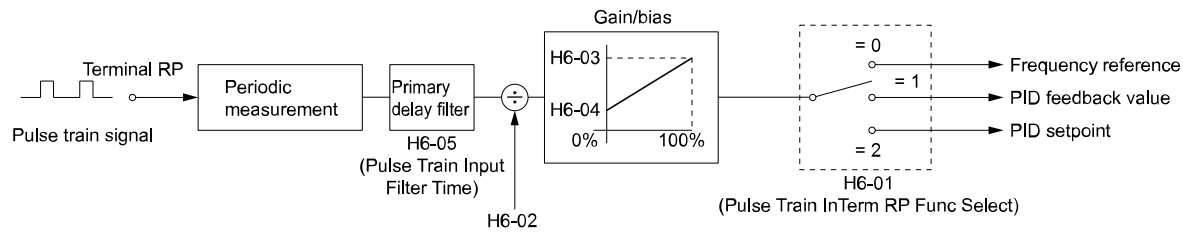


Figure 2.113 Pulse Train Input Block Diagram

### ■ H6-01: Terminal RP Pulse Train Function

| No. (Hex.)   | Name                             | Description   | Default (Range) |
|--------------|----------------------------------|---|-----------------|
| H6-01 (042C) | Terminal RP Pulse Train Function | <input type="checkbox"/> V/f <input type="checkbox"/> CL-V/f <input type="checkbox"/> OLV <input type="checkbox"/> CLV <input type="checkbox"/> AOLV <input type="checkbox"/> OLV/IPM <input type="checkbox"/> AOLV/IPM <input type="checkbox"/> CLV/IPM <input type="checkbox"/> EZOLV | 0 (0 - 3)       |

#### 0 : Frequency Reference

When  $b1-01$  [Frequency Reference Selection 1] or  $b1-15$  [Frequency Reference Selection 2] = 4 [Pulse Train Input], the drive inputs the frequency reference received from terminal RP.

#### 1 : PID Feedback Value

The drive inputs the PID control feedback value received from terminal RP.

#### 2 : PID Setpoint Value

The drive inputs the PID control target value received from terminal RP.

#### 3 : Speed Feedback (V/F Control)

Select V/f Control method to enable simple encoder feedback.

Use motor speed feedback for better speed control precision. The drive compares the frequency reference to the motor speed feedback received from the encoder, and uses the ASR function to compensate for motor slip. You cannot use input terminal RP used for the simple encoder to detect the direction of motor rotation. Use a different method to detect motor rotation.

Use these methods to detect the direction of motor rotation.

- Use MFDI  
Set MFDI  $H1-xx = 7E$  [Reverse Rotation Identifier]. When the configured terminal is activated, the motor operates in Reverse run. When the terminal is deactivated, the motor operates in Forward run.  
Use an encoder that outputs 2-tracks (phase A, B) to detect the direction of motor rotation.
- Use the frequency reference  
When you do not use the MFDI, the Forward/Reverse run command is the same as the direction of motor rotation.

Figure 2.114 shows speed control in Simple Closed Loop V/f Mode.



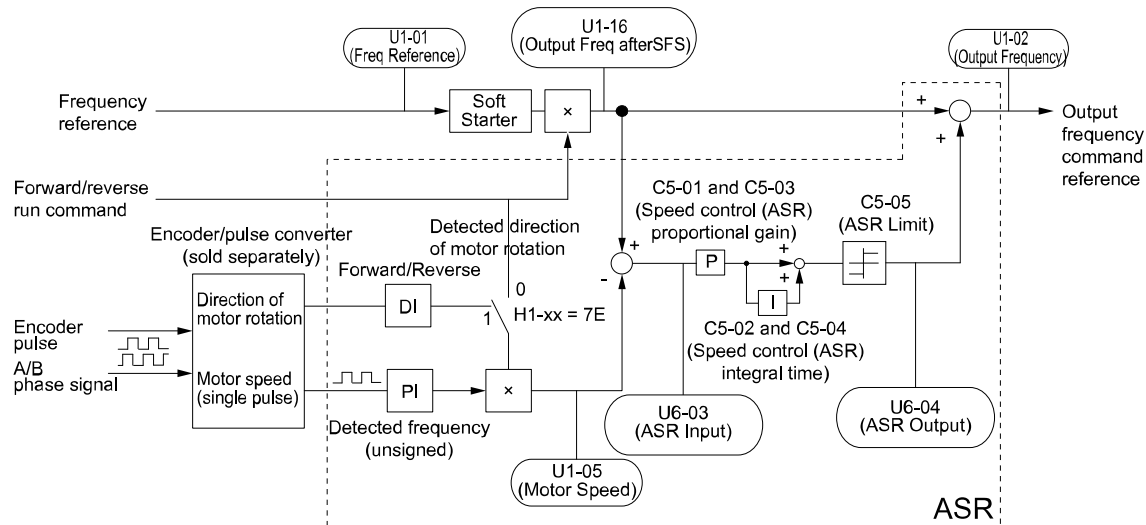


Figure 2.114 Simple Closed Loop Speed Control Block Diagram

**Enable Simple Closed Loop V/f Mode**

1. Connect the encoder output pulse wiring to terminal RP.
2. Set  $A1-02 = 0$  [Control Method Selection = V/f Control].
3. Set  $H6-01 = 3$ .
4. Set  $H6-02$  [Terminal RP Frequency Scaling] to the speed feedback (pulse train input signal) frequency at the time when the frequency reference is 100%.  
Make sure that  $H6-04$  [Terminal RP Function Bias] = 0% and  $H6-03$  [Terminal RP Function Gain] = 100%.
5. Select the detection method for the direction of motor rotation.  
When you use an MFDI, set  $H1-xx = 7E$ .
6. Set  $C5$  parameters related to ASR gain and integral time to adjust responsiveness.

**Note:**

- Set  $A1-02 = 0$  and  $H6-01 = 3$  to show  $C5$  parameters.
- You cannot use Closed Loop V/f Control mode with the Motor Switch function.

**H6-02: Terminal RP Frequency Scaling**

| No. (Hex.)       | Name                          | Description  | Default (Range)             |
|------------------|-------------------------------|--|-----------------------------|
| H6-02 (042D) RUN | Terminal RP Frequency Scaling | <b>V/f</b> <b>CL-V/f</b> <b>OLV</b> <b>CLV</b> <b>AOLV</b> <b>OLV/PM</b> <b>AOLV/PM</b> <b>CLV/PM</b> <b>EZOLV</b><br>Sets the frequency of the pulse train input signal used when the item selected with $H6-01$ [Terminal RP Pulse Train Function] is input at 100%. | 1440 Hz<br>(100 - 32000 Hz) |

**H6-03: Terminal RP Function Gain**

| No. (Hex.)       | Name                      | Description   | Default (Range)           |
|------------------|---------------------------|---|---------------------------|
| H6-03 (042E) RUN | Terminal RP Function Gain | <b>V/f</b> <b>CL-V/f</b> <b>OLV</b> <b>CLV</b> <b>AOLV</b> <b>OLV/PM</b> <b>AOLV/PM</b> <b>CLV/PM</b> <b>EZOLV</b><br>Sets the gain used when the function in $H6-01$ [Terminal RP Pulse Train Function] is input to terminal RP. | 100.0%<br>(0.0 - 1000.0%) |

**H6-04: Terminal RP Function Bias**

| No. (Hex.)       | Name                      | Description  | Default (Range)           |
|------------------|---------------------------|--|---------------------------|
| H6-04 (042F) RUN | Terminal RP Function Bias | <b>V/f</b> <b>CL-V/f</b> <b>OLV</b> <b>CLV</b> <b>AOLV</b> <b>OLV/PM</b> <b>AOLV/PM</b> <b>CLV/PM</b> <b>EZOLV</b><br>Sets the bias used when the function in $H6-01$ [Terminal RP Pulse Train Function] is input to terminal RP. Sets a value at the time when the pulse train is 0 Hz. | 0.0%<br>(-100.0 - 100.0%) |

Parameter Details

## 2.8 H: Terminal Functions

### ■ H6-05: Terminal RP Filter Time

| No. (Hex.)             | Name                    | Description   | Default (Range)           |
|------------------------|-------------------------|---|---------------------------|
| H6-05<br>(0430)<br>RUN | Terminal RP Filter Time | <b>V/f</b> <b>CL-V/f</b> <b>OLV</b> <b>CLV</b> <b>AOLV</b> <b>OLV/PM</b> <b>AOLV/PM</b> <b>CLV/PM</b> <b>EZOLV</b><br>Sets the time constant for the pulse train input primary delay filters. | 0.10 s<br>(0.00 - 2.00 s) |

### ■ H6-06: Terminal MP Monitor Selection

| No. (Hex.)             | Name                          | Description   | Default (Range)   |
|------------------------|-------------------------------|---|---|
| H6-06<br>(0431)<br>RUN | Terminal MP Monitor Selection | <b>V/f</b> <b>CL-V/f</b> <b>OLV</b> <b>CLV</b> <b>AOLV</b> <b>OLV/PM</b> <b>AOLV/PM</b> <b>CLV/PM</b> <b>EZOLV</b><br>Sets a function for pulse train monitor output terminal MP. Sets the "x-xx" part of the <i>Ux-xx</i> monitor. | 102<br>(000, 031, 101, 102, 105, 116, 501, 502, 801 - 809, 821 - 825, 831 - 839, 851 - 855) |

**Note:**

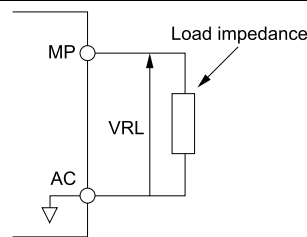
To use in through mode or when terminal MP is not used, set this parameter to 000 or 031.

When you use the pulse train monitor, make sure that you connect peripheral devices as specified by these load conditions:

Incorrect connections can make the characteristics not sufficient or cause mechanical damage.

- Use the pulse train monitor as the sourcing output.

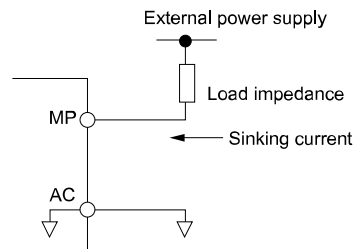
| Output Voltage VRL(V) | Load Impedance (kΩ) |
|-----------------------|---------------------|
| 5 V or more           | 1.5 kΩ or more      |
| 8 V or more           | 4.0 kΩ or more      |
| 10 V or more          | 10 kΩ or more       |



**Figure 2.115 Circuit Diagram When Used as the Sourcing Output**

- Use the pulse train monitor as the sinking input

| External Power Supply (V) | 12 VDC ± 10%, 15 VDC ± 10% |
|---------------------------|----------------------------|
| Sinking current (mA)      | 16 mA or less              |



**Figure 2.116 Circuit Diagram When Used as the Sinking Input**

■ H6-07: Terminal MP Frequency Scaling

| No. (Hex.)       | Name                          | Description   | Default (Range)        |
|------------------|-------------------------------|---|------------------------|
| H6-07 (0432) RUN | Terminal MP Frequency Scaling | <div style="display: flex; justify-content: space-between; font-size: 0.8em;"> <span>V/f</span> <span>CL-V/f</span> <span>OLV</span> <span>CLV</span> <span>AOLV</span> <span>OLV/PM</span> <span>AOLV/PM</span> <span>CLV/PM</span> <span>EZOLV</span> </div> <p>Sets the frequency of the pulse train output signal used when the monitor set with H6-06 [Terminal MP Monitor Selection] is 100%.</p> | 1440 Hz (0 - 32000 Hz) |

When H6-06 = 102 [Terminal MP Monitor Selection = Output Frequency] and H6-07 = 0, the pulse train output terminal MP outputs the same frequency as the drive output frequency.

■ H6-08: Terminal RP Minimum Frequency

| No. (Hex.)   | Name                          | Description   | Default (Range)          |
|--------------|-------------------------------|---|--------------------------|
| H6-08 (043F) | Terminal RP Minimum Frequency | <div style="display: flex; justify-content: space-between; font-size: 0.8em;"> <span>V/f</span> <span>CL-V/f</span> <span>OLV</span> <span>CLV</span> <span>AOLV</span> <span>OLV/PM</span> <span>AOLV/PM</span> <span>CLV/PM</span> <span>EZOLV</span> </div> <p>Sets the minimum frequency of the pulse train signal that terminal RP can detect.</p> | 0.5 Hz (0.1 - 1000.0 Hz) |

- When you input a pulse train frequency that is less than the value of H6-08, the pulse train input is 0.0 Hz.
- Set H6-01 [Terminal RP Pulse Train Function] = 0 [Frequency Reference], 1 [PID Feedback Value], or 2 [PID Setpoint Value] to enable this parameter.
- When H6-01 = 3 [Speed Feedback (V/F Control)], the drive applies the setting of F1-14 [Encoder Open-Circuit Detect Time] to the minimum frequency.

■ H6-09: Voltage Phase Sync MP Selection

| No. (Hex.)   | Name                            | Description  | Default (Range) |
|--------------|---------------------------------|--|-----------------|
| H6-09 (156E) | Voltage Phase Sync MP Selection | <div style="display: flex; justify-content: space-between; font-size: 0.8em;"> <span>V/f</span> <span>CL-V/f</span> <span>OLV</span> <span>CLV</span> <span>AOLV</span> <span>OLV/PM</span> <span>AOLV/PM</span> <span>CLV/PM</span> <span>EZOLV</span> </div> <p>Set whether to output the pulse synchronized with drive output voltage phase from the pulse train monitor output terminal MP. This parameter is only enabled when H6-06 = 102 [Terminal MP Monitor Selection = Output Frequency] and H6-07 = 0 [Terminal MP Frequency Scaling = 0 Hz].</p> | 0 (0, 1)        |

0 : Disabled

1 : Enabled

◆ H7: Virtual MFIO selection

The virtual I/O function performs the following.

- Inputs the result of the output from the MFDO terminal to the MFDI terminal without external wiring.
- Inputs the result of the output from the MFAO terminal to the MFAI terminal without external wiring.

**WARNING! Sudden Movement Hazard.** Before you do a test run, make sure that the setting values for virtual input and output function parameters are correct. Virtual input and output functions can have different default settings and operation than wired input and output functions. Incorrect function settings can cause serious injury or death.

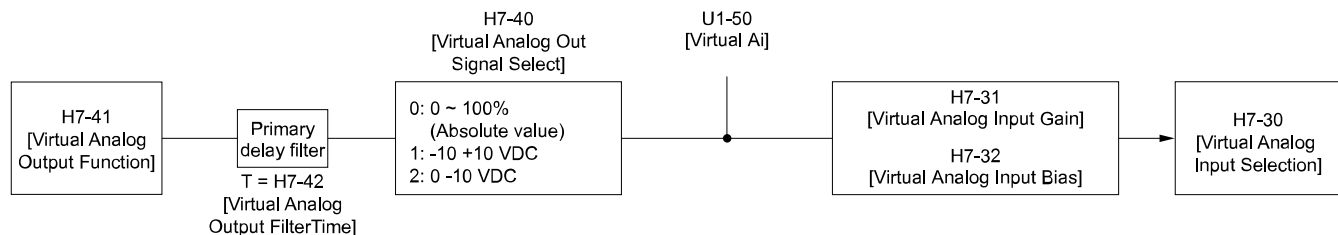
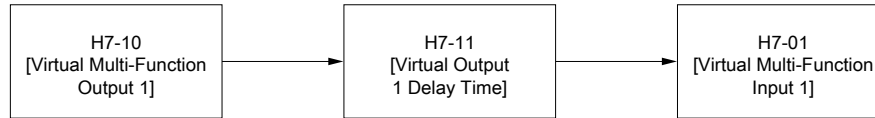


Figure 2.117 Virtual Analog I/O Functional Block Diagram

Parameter Details

## 2.8 H: Terminal Functions



**Figure 2.118 Virtual Digital I/O Functional Block Diagram**

**Note:**

- Refer to H1-xx "MFDI Setting Values" for more information on the virtual digital input setting values.
- Refer to H2-xx "MFDO Setting Values" for more information on the virtual digital output setting values.
- Refer to H3-xx "MFAI Setting Values" for more information on the virtual analog input setting values.
- Refer to H4-xx "MFAO Setting Values" for more information on the virtual analog output setting values.
- 0 [3-Wire Sequence] and 20 to 2F [External Fault] cannot be selected in H7-01 to H7-04 [Virtual Multi-Function Input 1 to 4].
- If the terminal is not used, set H7-01 to H7-04 = F. However, the through mode function is not supported.
- The virtual I/O function selection and the multi-function input for DI-A3 cannot be used simultaneously.

### ■ H7-00: Virtual MFIO selection

| No.<br>(Hex.)             | Name                   | Description   | Default<br>(Range) |
|---------------------------|------------------------|---|--------------------|
| H7-00<br>(116F)<br>Expert | Virtual MFIO selection | <div style="display: flex; gap: 5px;"> <span>V/f</span> <span>CL-V/f</span> <span>OLV</span> <span>CLV</span> <span>AOLV</span> <span>OLV/PM</span> <span>AOLV/PM</span> <span>CLV/PM</span> <span>EZOLV</span> </div> Sets the function to enable and disable the virtual I/O function. Set this parameter to 1 to operate the virtual I/O function. | 0<br>(0, 1)        |

**0 : Disabled**

**1 : Enabled**

### ■ H7-01: Virtual Multi-Function Input 1

| No.<br>(Hex.)             | Name                           | Description  | Default<br>(Range) |
|---------------------------|--------------------------------|--|--------------------|
| H7-01<br>(1185)<br>Expert | Virtual Multi-Function Input 1 | <div style="display: flex; gap: 5px;"> <span>V/f</span> <span>CL-V/f</span> <span>OLV</span> <span>CLV</span> <span>AOLV</span> <span>OLV/PM</span> <span>AOLV/PM</span> <span>CLV/PM</span> <span>EZOLV</span> </div> Sets the function that enters the virtual input set in H7-10 [Virtual Multi-Function Output 1]. | F<br>(1 - 19F)     |

### ■ H7-02: Virtual Multi-Function Input 2

| No.<br>(Hex.)             | Name                           | Description  | Default<br>(Range) |
|---------------------------|--------------------------------|--|--------------------|
| H7-02<br>(1186)<br>Expert | Virtual Multi-Function Input 2 | <div style="display: flex; gap: 5px;"> <span>V/f</span> <span>CL-V/f</span> <span>OLV</span> <span>CLV</span> <span>AOLV</span> <span>OLV/PM</span> <span>AOLV/PM</span> <span>CLV/PM</span> <span>EZOLV</span> </div> Sets the function that enters the virtual input set in H7-12 [Virtual Multi-Function Output 2]. | F<br>(1 - 19F)     |

### ■ H7-03: Virtual Multi-Function Input 3

| No.<br>(Hex.)             | Name                           | Description  | Default<br>(Range) |
|---------------------------|--------------------------------|--|--------------------|
| H7-03<br>(1187)<br>Expert | Virtual Multi-Function Input 3 | <div style="display: flex; gap: 5px;"> <span>V/f</span> <span>CL-V/f</span> <span>OLV</span> <span>CLV</span> <span>AOLV</span> <span>OLV/PM</span> <span>AOLV/PM</span> <span>CLV/PM</span> <span>EZOLV</span> </div> Sets the function that enters the virtual input set in H7-14 [Virtual Multi-Function Output 3]. | F<br>(1 - 19F)     |

### ■ H7-04: Virtual Multi-Function Input 4

| No.<br>(Hex.)             | Name                           | Description  | Default<br>(Range) |
|---------------------------|--------------------------------|--|--------------------|
| H7-04<br>(1188)<br>Expert | Virtual Multi-Function Input 4 | <div style="display: flex; gap: 5px;"> <span>V/f</span> <span>CL-V/f</span> <span>OLV</span> <span>CLV</span> <span>AOLV</span> <span>OLV/PM</span> <span>AOLV/PM</span> <span>CLV/PM</span> <span>EZOLV</span> </div> Sets the function that enters the virtual input set in H7-16 [Virtual Multi-Function Output 4]. | F<br>(1 - 19F)     |

### ■ H7-10: Virtual Multi-Function Output 1

| No.<br>(Hex.)             | Name                            | Description   | Default<br>(Range) |
|---------------------------|---------------------------------|---|--------------------|
| H7-10<br>(11A4)<br>Expert | Virtual Multi-Function Output 1 | <b>V/f</b> <b>CL-V/f</b> <b>OLV</b> <b>CLV</b> <b>AOLV</b> <b>OLV/PM</b> <b>AOLV/PM</b> <b>CLV/PM</b> <b>EZOLV</b><br>Sets the function for virtual digital output 1. | F<br>(0 - 1A7)     |

### ■ H7-11: Virtual Output 1 Delay Time

| No.<br>(Hex.)             | Name                        | Description  | Default<br>(Range)      |
|---------------------------|-----------------------------|--|-------------------------|
| H7-11<br>(11A5)<br>Expert | Virtual Output 1 Delay Time | <b>V/f</b> <b>CL-V/f</b> <b>OLV</b> <b>CLV</b> <b>AOLV</b> <b>OLV/PM</b> <b>AOLV/PM</b> <b>CLV/PM</b> <b>EZOLV</b><br>Sets the minimum ON time for virtual digital output 1. | 0.1 s<br>(0.0 - 25.0 s) |

### ■ H7-12: Virtual Multi-Function Output 2

| No.<br>(Hex.)             | Name                            | Description   | Default<br>(Range) |
|---------------------------|---------------------------------|---|--------------------|
| H7-12<br>(11A6)<br>Expert | Virtual Multi-Function Output 2 | <b>V/f</b> <b>CL-V/f</b> <b>OLV</b> <b>CLV</b> <b>AOLV</b> <b>OLV/PM</b> <b>AOLV/PM</b> <b>CLV/PM</b> <b>EZOLV</b><br>Sets the function for virtual digital output 2. | F<br>(0 - 1A7)     |

### ■ H7-13: Virtual Output 2 Delay Time

| No.<br>(Hex.)             | Name                        | Description  | Default<br>(Range)      |
|---------------------------|-----------------------------|--|-------------------------|
| H7-13<br>(11A7)<br>Expert | Virtual Output 2 Delay Time | <b>V/f</b> <b>CL-V/f</b> <b>OLV</b> <b>CLV</b> <b>AOLV</b> <b>OLV/PM</b> <b>AOLV/PM</b> <b>CLV/PM</b> <b>EZOLV</b><br>Sets the minimum ON time for virtual digital output 2. | 0.1 s<br>(0.0 - 25.0 s) |

### ■ H7-14: Virtual Multi-Function Output 3

| No.<br>(Hex.)             | Name                            | Description   | Default<br>(Range) |
|---------------------------|---------------------------------|---|--------------------|
| H7-14<br>(11A8)<br>Expert | Virtual Multi-Function Output 3 | <b>V/f</b> <b>CL-V/f</b> <b>OLV</b> <b>CLV</b> <b>AOLV</b> <b>OLV/PM</b> <b>AOLV/PM</b> <b>CLV/PM</b> <b>EZOLV</b><br>Sets the function for virtual digital output 3. | F<br>(0 - 1A7)     |

### ■ H7-15: Virtual Output 3 Delay Time

| No.<br>(Hex.)             | Name                        | Description  | Default<br>(Range)      |
|---------------------------|-----------------------------|--|-------------------------|
| H7-15<br>(11A9)<br>Expert | Virtual Output 3 Delay Time | <b>V/f</b> <b>CL-V/f</b> <b>OLV</b> <b>CLV</b> <b>AOLV</b> <b>OLV/PM</b> <b>AOLV/PM</b> <b>CLV/PM</b> <b>EZOLV</b><br>Sets the minimum ON time for virtual digital output 3. | 0.1 s<br>(0.0 - 25.0 s) |

### ■ H7-16: Virtual Multi-Function Output 4

| No.<br>(Hex.)             | Name                            | Description   | Default<br>(Range) |
|---------------------------|---------------------------------|---|--------------------|
| H7-16<br>(11AA)<br>Expert | Virtual Multi-Function Output 4 | <b>V/f</b> <b>CL-V/f</b> <b>OLV</b> <b>CLV</b> <b>AOLV</b> <b>OLV/PM</b> <b>AOLV/PM</b> <b>CLV/PM</b> <b>EZOLV</b><br>Sets the function for virtual digital output 4. | F<br>(0 - 1A7)     |

■ H7-17: Virtual Output 4 Delay Time

| No. (Hex.)                | Name                        | Description  | Default (Range)         |
|---------------------------|-----------------------------|--|-------------------------|
| H7-17<br>(11AB)<br>Expert | Virtual Output 4 Delay Time | <b>V/f</b> <b>CL-V/f</b> <b>OLV</b> <b>CLV</b> <b>AOLV</b> <b>OLV/PM</b> <b>AOLV/PM</b> <b>CLV/PM</b> <b>EZOLV</b><br>Sets the minimum ON time for virtual digital output 4. | 0.1 s<br>(0.0 - 25.0 s) |

■ H7-30: Sets the virtual analog input function.

| No. (Hex.)                | Name                                    | Description   | Default (Range) |
|---------------------------|---|---|-----------------|
| H7-30<br>(1177)<br>Expert | Sets the virtual analog input function. | <b>V/f</b> <b>CL-V/f</b> <b>OLV</b> <b>CLV</b> <b>AOLV</b> <b>OLV/PM</b> <b>AOLV/PM</b> <b>CLV/PM</b> <b>EZOLV</b><br>Sets the virtual analog input function. | F<br>(0 - 32)   |

■ H7-31: Virtual Analog Input Gain

| No. (Hex.)                       | Name                      | Description   | Default (Range)             |
|----------------------------------|---------------------------|---|-----------------------------|
| H7-31<br>(1178)<br>RUN<br>Expert | Virtual Analog Input Gain | <b>V/f</b> <b>CL-V/f</b> <b>OLV</b> <b>CLV</b> <b>AOLV</b> <b>OLV/PM</b> <b>AOLV/PM</b> <b>CLV/PM</b> <b>EZOLV</b><br>Sets the virtual analog input gain. | 100.0%<br>(-999.9 - 999.9%) |

■ H7-32: Virtual Analog Input Bias

| No. (Hex.)                       | Name                      | Description   | Default (Range)           |
|----------------------------------|---------------------------|---|---------------------------|
| H7-32<br>(1179)<br>RUN<br>Expert | Virtual Analog Input Bias | <b>V/f</b> <b>CL-V/f</b> <b>OLV</b> <b>CLV</b> <b>AOLV</b> <b>OLV/PM</b> <b>AOLV/PM</b> <b>CLV/PM</b> <b>EZOLV</b><br>Sets the virtual analog input bias. | 0.0%<br>(-999.9 - 999.9%) |

■ H7-40: Virtual Analog Out Signal Select

| No. (Hex.)      | Name                             | Description   | Default (Range) |
|-----------------|----------------------------------|---|-----------------|
| H7-40<br>(1163) | Virtual Analog Out Signal Select | <b>V/f</b> <b>CL-V/f</b> <b>OLV</b> <b>CLV</b> <b>AOLV</b> <b>OLV/PM</b> <b>AOLV/PM</b> <b>CLV/PM</b> <b>EZOLV</b><br>Sets the signal level of the virtual analog output. | 0<br>(0 - 2)    |

0 : 0 to 100% (Absolute Value)

1 : -100 to 100%

2 : 0 to 100% (Lower Limit at 0)

■ H7-41: Virtual Analog Output Function

| No. (Hex.)      | Name                           | Description   | Default (Range)  |
|-----------------|--------------------------------|---|------------------|
| H7-41<br>(1164) | Virtual Analog Output Function | <b>V/f</b> <b>CL-V/f</b> <b>OLV</b> <b>CLV</b> <b>AOLV</b> <b>OLV/PM</b> <b>AOLV/PM</b> <b>CLV/PM</b> <b>EZOLV</b><br>Sets the monitor to be output from the virtual analog output. | 102<br>(0 - 999) |

Set the *x-xx* part of the *Ux-xx* [Monitor]. For example, set H7-41 = 102 to monitor U1-02 [Output Frequency].

■ H7-42: Virtual Analog Output FilterTime

| No. (Hex.)      | Name                             | Description   | Default (Range)           |
|-----------------|----------------------------------|---|---------------------------|
| H7-42<br>(1165) | Virtual Analog Output FilterTime | <b>V/f</b> <b>CL-V/f</b> <b>OLV</b> <b>CLV</b> <b>AOLV</b> <b>OLV/PM</b> <b>AOLV/PM</b> <b>CLV/PM</b> <b>EZOLV</b><br>Sets the time constant for a primary filter of the virtual analog output. | 0.00 s<br>(0.00 - 2.00 s) |

## 2.9 L: Protection Functions

*L* parameters set the following functions.

- Motor Overload Protection
- Operation During Momentary Power Loss
- Stall Prevention
- Speed Detection
- Auto Restart
- Detection of Overtorque/Undertorque
- Torque Limit
- Hardware Protection

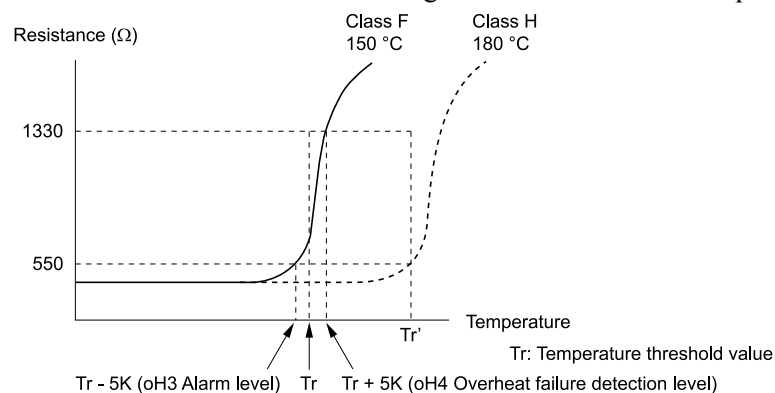
### ◆ L1: Motor Protection

*L1* parameters set the motor overload protection function.

#### ■ Motor Protection Using Positive Temperature Coefficient (PTC) Thermistors

The temperature resistance characteristics of three PTC thermistors in the motor stator winding protect the motor from overheat.

The PTC thermistor must have the characteristics shown in Figure 2.119 for each motor phase.



**Figure 2.119 PTC Thermistor Temperature and Resistance**

When the PTC input signal input to the drive is more than the overload alarm level, the drive detects *oH3* [*Motor Overheat (PTC Input)*]. The drive continues the operation set in *L1-03* [*Motor Thermistor oH Alarm Select*]. By factory default, *oH3* flashes on the keypad and the drive continues operation.

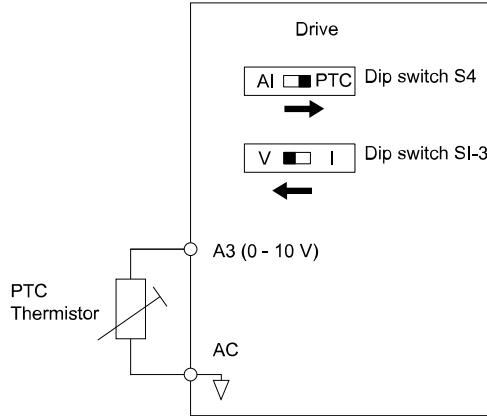
The overheat fault level triggers an *oH4* [*Motor Overheat Fault (PTC Input)*] fault, and outputs a fault signal. The drive outputs a fault signal, and stops the motor with the stop method set in *L1-04* [*Motor Thermistor oH Fault Select*].

**Note:**

PTC is an acronym for Positive Temperature Coefficient.

Figure 2.120 shows the configuration procedure when you use terminal A3.

1. Connect the PTC thermistor input from the motor to analog input terminal A3 on the drive.



**Figure 2.120 Connect Motor PTC**

2. Set drive DIP switch S1-3 to V (voltage) and set DIP switch S4 to PTC.
3. Set these MFAI terminals:
  - Set H3-05 = 0 [Terminal A3 Signal Level Select = 0 to 10V (Lower Limit at 0)].
  - Set H3-06 = E [Terminal A3 Function Selection = Motor Temperature (PTC input)].
4. Set these L1 parameters:
  - L1-03 [Motor Thermistor oH Alarm Select]
  - L1-04 [Motor Thermistor oH Fault Select]
  - L1-05 [Motor Thermistor Filter Time]

**■ L1-01: Motor Overload (oL1) Protection**

| No. (Hex.)   | Name                            | Description   | Default (Range)             |
|--------------|---------------------------------|---|-----------------------------|
| L1-01 (0480) | Motor Overload (oL1) Protection | <span style="border: 1px solid black; border-radius: 3px; padding: 2px;">V/f</span> <span style="border: 1px solid black; border-radius: 3px; padding: 2px;">CL-V/f</span> <span style="border: 1px solid black; border-radius: 3px; padding: 2px;">OLV</span> <span style="border: 1px solid black; border-radius: 3px; padding: 2px;">CLV</span> <span style="border: 1px solid black; border-radius: 3px; padding: 2px;">AOLV</span> <span style="border: 1px solid black; border-radius: 3px; padding: 2px;">OLV/PM</span> <span style="border: 1px solid black; border-radius: 3px; padding: 2px;">AOLV/PM</span> <span style="border: 1px solid black; border-radius: 3px; padding: 2px;">CLV/PM</span> <span style="border: 1px solid black; border-radius: 3px; padding: 2px;">EZOLV</span><br>Sets the motor overload protection with electronic thermal protectors. | Determined by A1-02 (0 - 6) |

This parameter enables and disables the motor overload protection with electronic thermal protectors.

The cooling capability of the motor changes when the speed control range of the motor changes. Use an electronic thermal protector that aligns with the permitted load characteristics of the motor to select motor protection.

The electronic thermal protector of the drive uses these items to calculate motor overload tolerance and supply overload protection for the motor:

- Output Current
- Output Frequency
- Motor thermal characteristics
- Time characteristics

If the drive detects motor overload, the drive will trigger an oL1 [Motor Overload] and stop the drive output.

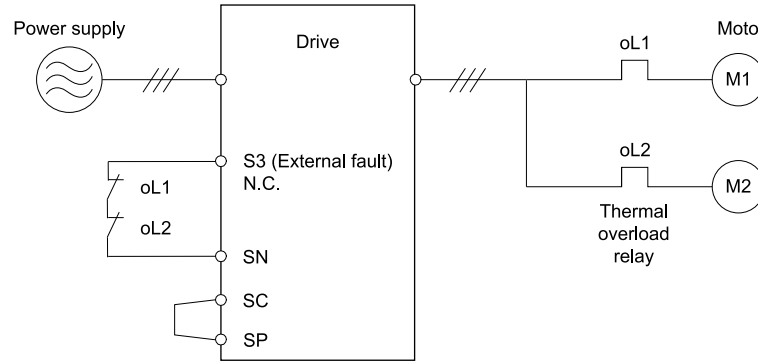
Set H2-01 = 1F [Term M1-M2 Function Selection = Motor Overload Alarm (oL1)] to set a motor overload alarm. If the motor overload level is more than 90% of the oL1 detection level, the output terminal turns ON and triggers an overload alarm.

**0 : No**

Disable motor protection when motor overload protection is not necessary or when the drive is operating more than one motor.

Refer to Figure 2.121 for an example of the circuit configuration to connect more than one motor to one drive.





**Figure 2.121 Protection Circuit Configuration to Connect More than One Motor to One Drive**

**NOTICE:** When you connect more than one motor to one drive or when the motor amp rating is higher than the drive amp rating, set L1-01 = 0 [Motor Overload (oL1) Protection = Disabled] and install thermal overload relays for each motor. The electronic thermal protection of the drive will not function and it can cause damage to the motor.

**1 : Variable Torque**

Use this setting for general-purpose motors with a 60 Hz base frequency.

The overload tolerance decreases as motor speed decreases because the cooling fan speed decreases and the ability of the motor to cool decreases in the low speed range.

The overload tolerance characteristics of the motor change the trigger point for the electronic thermal protector. This provides motor overheat protection from low speed to high speed across the full speed range.

| Load Tolerance | Cooling Capability  | Overload Characteristics (at 100% motor load)   |
|----------------|---|---|
|                | <p>This motor is designed to operate with commercial line power. Operate at a 60 Hz base frequency to maximize the motor cooling ability.</p> | <p>If the motor operates at frequencies less than 60 Hz, the drive will detect oL1. The drive triggers a fault relay output and the motor coasts to stop.</p> |

**2 : Constant Torque 10:1 Speed Range**

Use this setting for drive-dedicated motors with a speed range for constant torque of 1:10.

The speed control for this motor is 10% to 100% when at 100% load. If the motor operates at slower than 10% speed with 100% load, it will cause motor overload.

| Load Tolerance | Cooling Capability   | Overload Characteristics (at 100% motor load)   |
|----------------|--|---|
|                | <p>This motor is designed to withstand increased temperatures during continuous operation in the low speed range (10% base frequency).</p> | <p>The motor operates continuously at 10% to 100% base frequency. Operating slower than 10% speed at 100% load will cause motor overload.</p> |

Parameter Details

## 2.9 L: Protection Functions

### 3 : Constant Torque 100:1 SpeedRange

Use this setting for vector motors with a speed range for constant torque of 1:100.

The speed control for this motor is 1% to 100% when at 100% load. If the motor operates at slower than 1% speed with 100% load, it will cause motor overload.

| Load Tolerance | Cooling Capability  | Overload Characteristics (at 100% motor load)   |
|----------------|---|---|
|                | <p>This motor is designed to withstand increased temperatures during continuous operation in the low speed range (1% base frequency).</p> | <p>The motor operates continuously at 1% to 100% base frequency. Operating slower than 1% speed at 100% load will cause motor overload.</p> |

### 4 : PM Variable Torque

Use this setting for PM motors with derated torque characteristics.

The overload tolerance decreases as motor speed decreases because the cooling fan speed decreases and the ability of the motor to cool decreases in the low speed range.

The overload tolerance characteristics of the motor change the trigger point for the electronic thermal protector. This provides motor overheat protection from low speed to high speed across the full speed range.

| Load Tolerance | Cooling Capability   | Overload Characteristics (at 100% motor load)  |
|----------------|--|--|
|                | <p>This motor is designed to withstand increased temperatures during continuous operation at rated speed and rated torque.</p> | <p>If the motor operates continuously at lower speed than rated rotation speed at more than 100% torque, the drive will detect <i>oLL</i>. The drive triggers a fault relay output and the motor coasts to stop.</p> |

### 5 : PM Constant Torque

Use this setting with a PM motor for constant torque that has a speed range for constant torque of 1:500.

The speed control for this motor is 0.2% to 100% when at 100% load. If the motor operates at slower than 0.2% speed with 100% load, it will cause motor overload.

| Load Tolerance | Cooling Capability  | Overload Characteristics (at 100% motor load)  |
|----------------|---|--|
|                | <p>This motor is designed to withstand increased temperatures during continuous operation in the low speed range (0.2% base frequency).</p> | <p>The motor operates continuously at 0.2% to 100% rated speed. Operating slower than 0.2% speed at 100% load will cause motor overload.</p> |

### 6 : Variable Torque (50Hz)

Use this setting for general-purpose motors with a 50 Hz base frequency.

The overload tolerance decreases as motor speed decreases because the cooling fan speed decreases and the ability of the motor to cool decreases in the low speed range.

The overload tolerance characteristics of the motor change the trigger point for the electronic thermal protector. This provides motor overheat protection from low speed to high speed across the full speed range.

| Load Tolerance | Cooling Capability  | Overload Characteristics (at 100% motor load)  |
|----------------|---|--|
|                | <p>This motor is designed to operate with commercial line power. Operate at a 50 Hz base frequency to maximize the motor cooling ability.</p> | <p>If the motor operates at frequencies less than commercial line power, the drive will detect <i>oL1</i>. The drive triggers a fault relay output and the motor coasts to stop.</p> |

■ L1-02: Motor Overload Protection Time

| No. (Hex.)   | Name                           | Description  | Default (Range)         |
|--------------|--------------------------------|--|-------------------------|
| L1-02 (0481) | Motor Overload Protection Time | <p><b>V/f CL-V/f OLV CLV AOLV OLV/PM AOLV/PM CLV/PM EZOLV</b></p> <p>Sets the operation time for the electronic thermal protector of the drive to prevent damage to the motor. Usually it is not necessary to change this setting.</p> | 1.0 min (0.1 - 5.0 min) |

Set the overload tolerance time to the length of time that the motor can operate at 150% load from continuous operation at 100% load.

When the motor operates at 150% load continuously for 1 minute after continuous operation at 100% load (hot start), the default setting triggers the electronic thermal protector.

Figure 2.122 shows an example of the electronic thermal protector operation time. Motor overload protection operates in the range between a cold start and a hot start.

This example shows a general-purpose motor operating at the base frequency with *L1-02* set to 1.0 min.

- Cold start  
Shows the motor protection operation time characteristics when the overload occurs immediately after starting operation from a complete stop.
- Hot start  
Shows the motor protection operation time characteristics when overload occurs from continuous operation below the motor rated current.

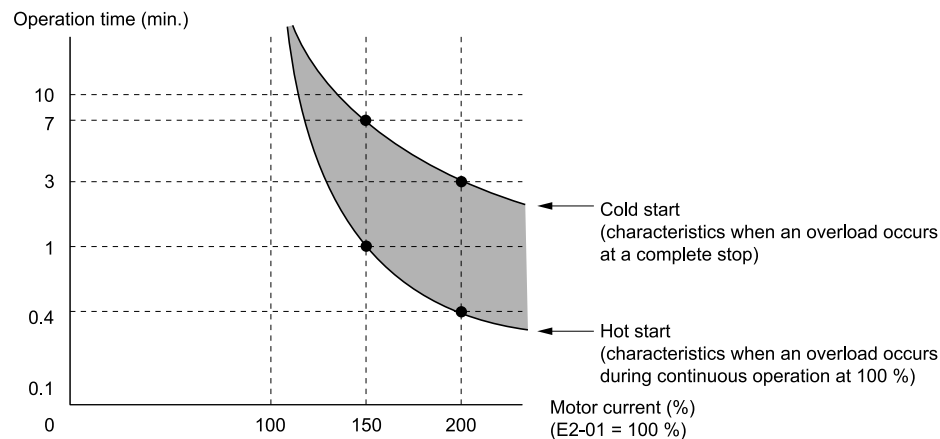


Figure 2.122 Protection Operation Time for a General-purpose Motor at Rated Output Frequency

## 2.9 L: Protection Functions

### ■ L1-03: Motor Thermistor oH Alarm Select

| No. (Hex.)      | Name                             | Description  | Default (Range) |
|-----------------|----------------------------------|--|-----------------|
| L1-03<br>(0482) | Motor Thermistor oH Alarm Select | <b>V/f</b> <b>CL-V/f</b> <b>OLV</b> <b>CLV</b> <b>AOLV</b> <b>OLV/PM</b> <b>AOLV/PM</b> <b>CLV/PM</b> <b>EZOLV</b><br>Sets drive operation when the PTC input signal entered into the drive is at the <i>oH3 [Motor Overheat Alarm]</i> detection level. | 3<br>(0 - 3)    |

#### 0 : Ramp to Stop

The drive ramps the motor to stop in the deceleration time. Fault relay output terminal MA-MC turns ON and MB-MC turns OFF.

#### 1 : Coast to Stop

The output turns OFF and the motor coasts to stop. Fault relay output terminal MA-MC turns ON, and MB-MC turns OFF.

#### 2 : Fast Stop (Use C1-09)

The drive stops the motor in the deceleration time set in *C1-09 [Fast Stop Time]*. Fault relay output terminal MA-MC turns ON, and MB-MC turns OFF.

#### 3 : Alarm Only

The keypad shows *oH3*, and operation continues. The output terminal set for *Alarm [H2-01 to H2-03 = 10]* turns ON.

### ■ L1-04: Motor Thermistor oH Fault Select

| No. (Hex.)      | Name                             | Description  | Default (Range) |
|-----------------|----------------------------------|--|-----------------|
| L1-04<br>(0483) | Motor Thermistor oH Fault Select | <b>V/f</b> <b>CL-V/f</b> <b>OLV</b> <b>CLV</b> <b>AOLV</b> <b>OLV/PM</b> <b>AOLV/PM</b> <b>CLV/PM</b> <b>EZOLV</b><br>Sets the drive operation when the PTC input signal to the drive is at the <i>oH4 [Motor Overheat Fault (PTC Input)]</i> detection level. | 1<br>(0 - 2)    |

#### 0 : Ramp to Stop

The drive ramps the motor to stop in the deceleration time. Fault relay output terminal MA-MC turns ON and MB-MC turns OFF.

#### 1 : Coast to Stop

The output turns OFF and the motor coasts to stop. Fault relay output terminal MA-MC turns ON, and MB-MC turns OFF.

#### 2 : Fast Stop (Use C1-09)

The drive stops the motor in the deceleration time set in *C1-09 [Fast Stop Time]*. Fault relay output terminal MA-MC turns ON, and MB-MC turns OFF.

### ■ L1-05: Motor Thermistor Filter Time

| No. (Hex.)      | Name                         | Description   | Default (Range)            |
|-----------------|------------------------------|---|----------------------------|
| L1-05<br>(0484) | Motor Thermistor Filter Time | <b>V/f</b> <b>CL-V/f</b> <b>OLV</b> <b>CLV</b> <b>AOLV</b> <b>OLV/PM</b> <b>AOLV/PM</b> <b>CLV/PM</b> <b>EZOLV</b><br>Sets the primary delay time constant for the PTC input signal entered to the drive. This parameter prevents accidental motor overheat faults. | 0.20 s<br>(0.00 - 10.00 s) |

### ■ L1-08: oL1 Current Level

| No. (Hex.)      | Name                          | Description  | Default (Range)  |
|-----------------|-------------------------------|--|--|
| L1-08<br>(1103) | oL1 Current Level for Motor 1 | <b>V/f</b> <b>CL-V/f</b> <b>OLV</b> <b>CLV</b> <b>AOLV</b> <b>OLV/PM</b> <b>AOLV/PM</b> <b>CLV/PM</b> <b>EZOLV</b><br>Sets the reference current for the motor 1 thermal overload detection. When the current level > 0.0 A, you cannot set this value < 10% of drive rated current. | 0.0 A<br>(0.0 A or 10% to 150% of the drive rated current) |

When *L1-08 = 0.0 A*, the drive uses *E2-01 [Motor Rated Current (FLA)]* to detect the motor overload protection. In PM control mode, the drive uses *E5-03 [PM Motor Rated Current (FLA)]* to detect the motor overload protection.

When *L1-08 ≠ 0.0 A*, the set value is the reference for motor overload protection.

**Note:**

- Display is in these units:
  - Models 2004 to 2042, 4002 to 4023: 0.01 A
  - Models 2056 to 2415, 4031 to 4720: 0.1 A
- When the current level > 0.0 A, you cannot set this value < 10% of drive rated current.

**■ L1-09: oL1 Current Level for Motor 2**

| No. (Hex.)   | Name                          | Description   | Default (Range)   |
|--------------|-------------------------------|---|---|
| L1-09 (1104) | oL1 Current Level for Motor 2 | V/f CL-V/f OLV CLV AOLV OLV/PM AOLV/PM CLV/PM EZOLV<br>Sets the reference current for the motor 2 thermal overload detection. When the current level > 0.0 A, you cannot set this value < 10% of drive rated current. | 0.0 A<br>(0.0 A or 10 to 150% of the drive rated current) |

When  $L1-09 = 0.0 A$ , the drive uses  $E4-01$  [Motor 2 Rated Current] to detect the motor overload protection.

When  $L1-09 \neq 0.0 A$ , the set value is the reference for motor overload protection.

**Note:**

- Display is in these units:
  - Models 2004 to 2042, 4002 to 4023: 0.01 A
  - Models 2056 to 2415, 4031 to 4720: 0.1 A
- When the current level > 0.0 A, you cannot set this value < 10% of drive rated current.

**■ L1-13: Motor Overload Memory Selection**

| No. (Hex.)   | Name                            | Description  | Default (Range) |
|--------------|---------------------------------|--|-----------------|
| L1-13 (046D) | Motor Overload Memory Selection | V/f CL-V/f OLV CLV AOLV OLV/PM AOLV/PM CLV/PM EZOLV<br>Sets the function that keeps the current electronic thermal protector value when the drive stops receiving power. | 1<br>(0, 1)     |

**0 : Disabled**

**1 : Enabled**

Sets if the drive will calculate the motor again when the drive is energized again.

**◆ L2: Power Loss Ride Through**

$L2$  parameters set the drive operation during momentary power loss and the KEB Ride-Thru function method of operation.

**■ KEB Ride-Thru Function**

KEB is an acronym for Kinetic Energy Backup. If the drive detects a power loss or momentary power loss, it will quickly decelerate the motor. The drive uses regenerative energy from the motor to keep the main circuit operating. When you return power during motor deceleration, the drive returns operation to the status before the power loss. The KEB Ride-Thru function is different than other functions for continuous operation. If the drive detects momentary power loss, the motor will ramp to stop. It will not coast to stop. This function is applicable for applications in which it is necessary to prevent materials from running out, for example control for film and fiber lines.

The KEB Ride-Thru function has 4 methods of operation. Parameter  $L2-29$  [Kinetic Energy Backup Method] sets the method.

When you use the KEB Ride-Thru function with one drive, set  $L2-29 = 0, 1$  [Single Drive KEB Ride-Thru 1, Single Drive KEB Ride-Thru 2].

If deceleration in coordination with more than one drive is necessary, for example textile machinery line systems, set  $L2-29 = 2, 3$  [System KEB Ride-Thru 1, System KEB Ride-Thru 2].

## 2.9 L: Protection Functions

**Table 2.66 KEB Ride-Thru Function Operation Method**

| L2-29 | Kinetic Energy Backup Method | Operation  | Configuration Precautions   |
|-------|------------------------------|--|---|
| 0     | Single Drive KEB Ride-Thru 1 | The drive uses regenerative energy from the motor to keep the DC bus voltage at the level set in L2-11 [KEB DC Bus Voltage Setpoint] while it adjusts the rate of deceleration.<br>The KEB operation continues while the drive adjusts the deceleration rate with the setting of C1-09 [Fast Stop Time]. | <ul style="list-style-type: none"> <li>Set C1-09 correctly to prevent <i>Uv1</i> [DC Bus Undervoltage] and <i>ov</i> [Overvoltage].</li> <li>If the drive detects <i>Uv1</i> during the KEB operation, decrease the value set in C1-09.</li> <li>If the drive detects <i>ov</i> during the KEB operation, increase the value set in C1-09.</li> </ul> |
| 1     | Single Drive KEB Ride-Thru 2 | The drive uses information about the inertia of the connected machinery to find the deceleration rate necessary to keep the DC bus voltage at the level set in parameter L2-11.<br>The drive uses system inertia to calculate the deceleration time. You cannot adjust this value.                       | <ul style="list-style-type: none"> <li>If the drive detects <i>Uv1</i> during the KEB operation, increase the setting value of L3-20 [DC Bus Voltage Adjustment Gain] and L3-21 [OV/Suppression Accel/Decel P Gain].</li> <li>If the drive detects <i>ov</i> during the KEB operation, decrease the setting value of L3-20 and L3-21.</li> </ul>      |
| 2     | System KEB Ride-Thru 1       | The drive does not monitor the DC bus voltage. The drive decelerates at the KEB deceleration time set in L2-06.<br>Use L2-06 to set the time necessary to decelerate from the current frequency reference to 0 Hz. More than one drive can decelerate and keep a constant speed ratio between drives.    | Use the dynamic braking option with System KEB Ride-Thru 1.   |
| 3     | System KEB Ride-Thru 2       | The drive uses the KEB deceleration time set in L2-06 to decelerate and it also monitors the DC bus voltage.<br>If the voltage level increases, the drive momentarily holds the frequency to prevent an <i>ov</i> before it continues to decelerate.   | If you cannot use the dynamic braking option, use System KEB Ride-Thru 2.   |

### ■ KEB Ride Thru Start

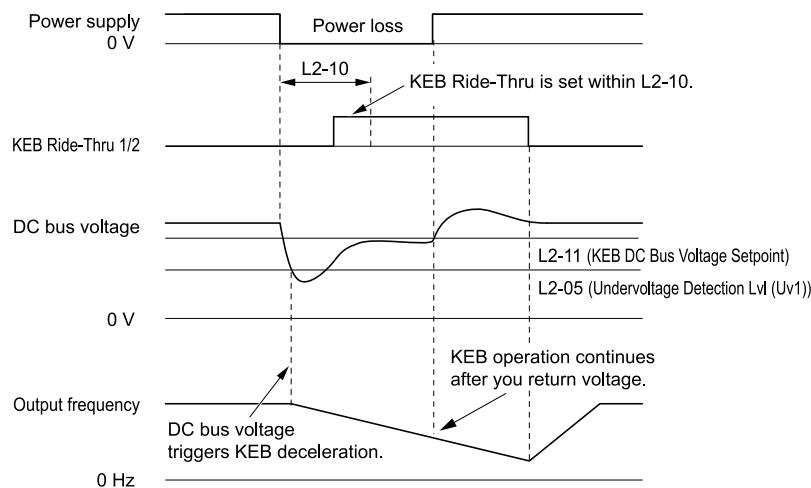
When L2-01 = 3, 4, 5 [Power Loss Ride Through Select = Kinetic Energy Backup: L2-02, Kinetic Energy Backup: CPU Power, Kinetic Energy Backup: DecelStop], the drive starts the KEB operation immediately after it detects a momentary power loss. When one of these conditions occur, the drive will activate KEB Ride-Thru:

- KEB Ride-Thru 1 set for the MFDI terminal becomes enabled (terminal is deactivated when HI-xx = 65 or terminal is activated when HI-xx = 66).  
The drive uses the mode selected L2-29 [Kinetic Energy Backup Method] to start KEB operation.
- KEB Ride-Thru 2 set for the MFDI terminal becomes enabled (terminal is deactivated when HI-xx = 7A or terminal is activated when HI-xx = 7B).  
The drive automatically starts Single KEB Ride-Thru 2 and it ignores the setting of L2-29.
- The DC bus voltage is less than the level set in L2-05 [Undervoltage Detection Lvl (Uv1)].  
The KEB operation will start as specified in L2-29.

#### Note:

If you try to set KEB Ride-Thru 1 and 2 to the MFDI terminals at the same time, it will trigger *oPE03* [Multi-Function Input Setting Err].

In this example, the drive detects that the DC bus voltage is less than the level set in L2-05 and starts the KEB operation. When you return power during KEB operation, the drive will continue KEB operation when the KEB Ride-Thru is input, although the time set in L2-10 [Minimum KEB Time] expired. The motor accelerates again after you cancel the KEB Ride-Thru.



**Figure 2.123 KEB Operation through KEB Ride-Thru Input**

## ■ KEB Ride-Thru End Detection

Parameter *L2-01* [*Power Loss Ride Through Select*] and a digital input programmed for KEB set the KEB function end detection.

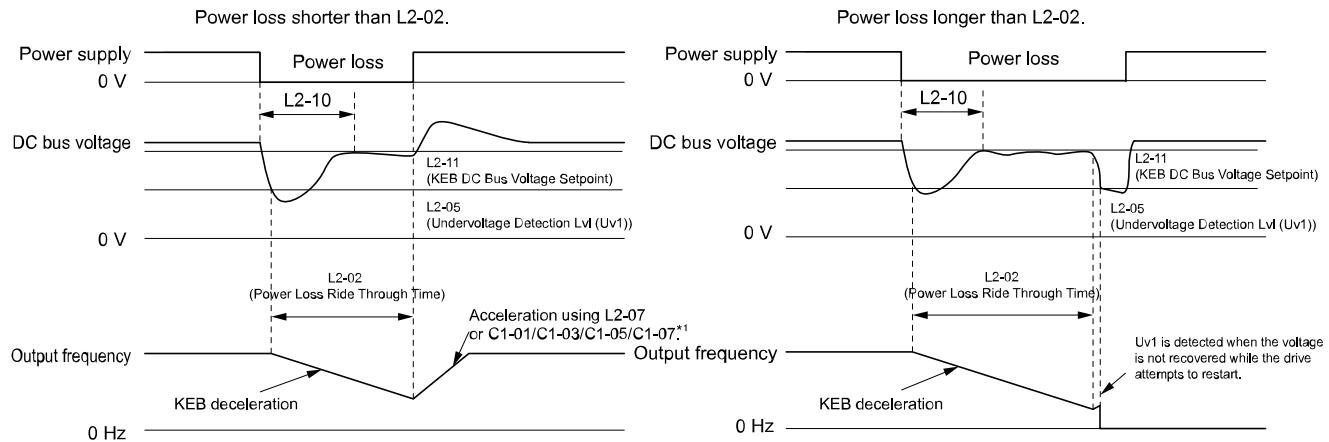
### Use the Momentary Power Loss Ride-Thru Time to Cancel KEB Operation

shows an example with this configuration:

- *L2-01* = 3 [*Kinetic Energy Backup: L2-02*] is set.
- KEB Ride-Thru is not used.

The drive starts deceleration through KEB operation. When the time set in *L2-10* [*Minimum KEB Time*] expires, the drive stops the KEB operation and then it accelerates the motor again until it is at the frequency reference value used before the power loss.

If you do not return the DC bus voltage in the time set in *L2-02* [*Power Loss Ride Through Time*], the drive detects *Uv1* [*DC Bus Undervoltage*] and the drive turns off its output.



**Figure 2.124 Cancel the KEB Operation after the Momentary Power Loss Ride-Thru Time Is Expired without KEB Ride-Thru**

- \*1 When *L2-07* = 0.00 [*Kinetic Energy Backup Accel Time* = 0.00 s], the drive accelerates again as specified by the applicable *Acceleration Time* [*C1-01*, *C1-03*, *C1-05*, *C1-07*], and usual operation continues.

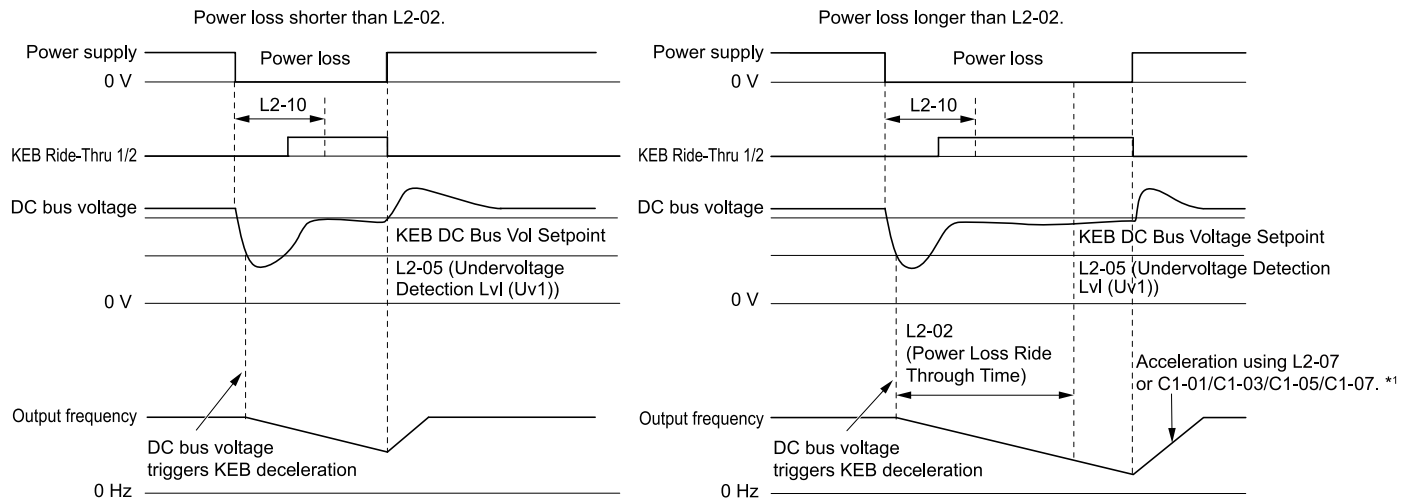
### Use the Momentary Power Loss Ride-Thru Time and KEB Ride-Thru to Cancel KEB Operation

shows an example with this configuration:

- *L2-01* = 3.
- Use *KEB Ride-Thru 1* [*H1-xx* = 65, 66] or *KEB Ride-Thru 2* [*H1-xx* = 7A, 7B].

The drive starts deceleration through KEB operation. The drive decelerates for the time set in parameter *L2-10*, then it measures the DC bus voltage and the status of the digital input terminal set for KEB Ride-Thru. When the DC bus voltage is less than the level set in *L2-11* [*KEB DC Bus Voltage Setpoint*], or if the KEB digital input is active, KEB deceleration continues. When the DC bus voltage is more than the level set in *L2-11*, the drive ends KEB operation. The drive accelerates the motor to the frequency reference value before the power loss, and usual operation continues. If the time set in *L2-02* is expired, the drive detects *Uv1*. When you cancel the KEB Ride-Thru, the motor accelerates again, and usual operation continues.

## 2.9 L: Protection Functions



**Figure 2.125 Use the Momentary Power Loss Ride-Through Time and KEB Ride-Through to Cancel KEB Operation**

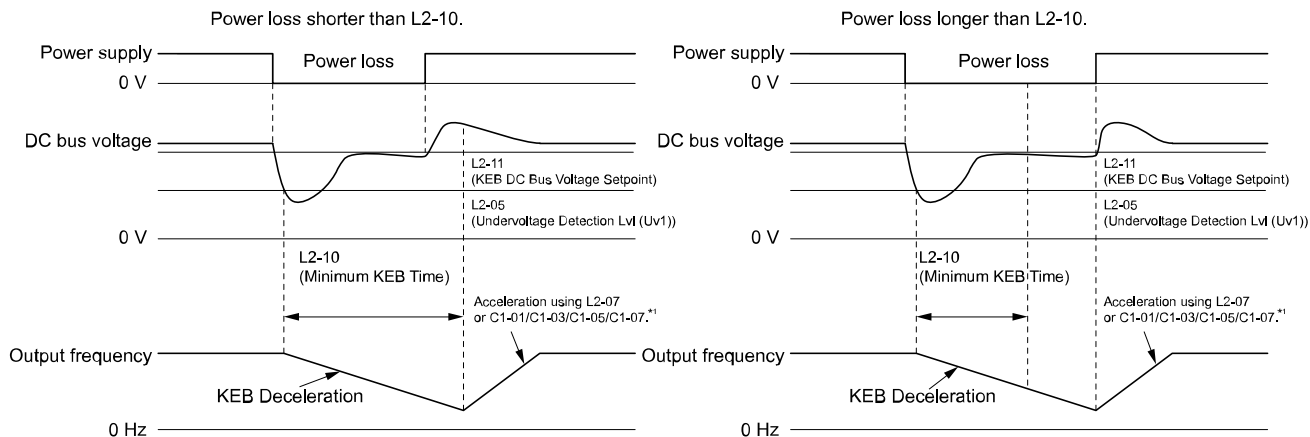
\*1 When  $L2-07 = 0.00$ , the drive accelerates again as specified by the applicable *Acceleration Time* [ $C1-01$ ,  $C1-03$ ,  $C1-05$ ,  $C1-07$ ], and usual operation continues.

### Cancel KEB Operation When Restoration of Power Occurs while the Control Power (Power Supply to the Control Board) is Maintained

shows an example with this configuration:

- $L2-01 = 4$  [*Kinetic Energy Backup: CPU Power*] is set.
- KEB Ride-Through is not used.

The drive starts deceleration through KEB operation. The drive decelerates for the time set in parameter  $L2-10$ , and then measures the DC bus voltage level. When the DC bus voltage is lower than the level set in  $L2-11$ , the drive uses the KEB Ride-Through function to continue deceleration. When the DC bus voltage is more than the level set in  $L2-11$ , usual operation continues. The drive accelerates the motor to the frequency reference value before the power loss, and usual operation continues.



**Figure 2.126 Cancel KEB Operation without Using the KEB Ride-Through if Restoration of Power Occurs while the Control Power (Power Supply to the Control Board) is Maintained**

\*1 When  $L2-07 = 0.00$  s, the drive accelerates again as specified by the applicable *Acceleration Time* [ $C1-01$ ,  $C1-03$ ,  $C1-05$ ,  $C1-07$ ], and usual operation continues.

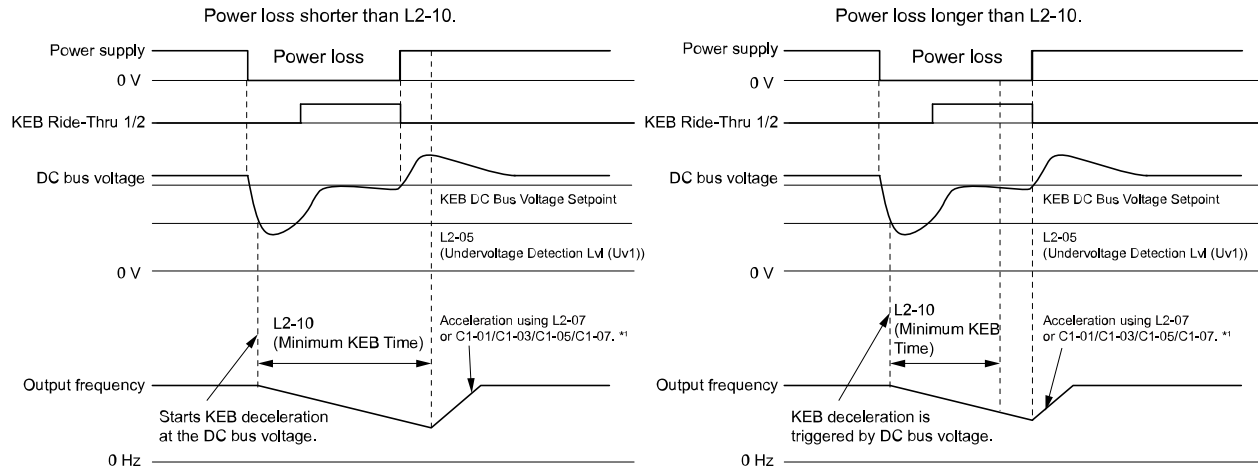
### Use the KEB Ride-Through to Cancel KEB Operation when Restoration of Power Occurs while the Control Power (Power Supply to the Control Board) is Maintained

shows an example with this configuration:

- $L2-01 = 4$ .
- Use *KEB Ride-Through 1* [ $H1-xx = 65, 66$ ] or *KEB Ride-Through 2* [ $H1-xx = 7A, 7B$ ].



The drive starts deceleration through KEB operation. When the motor decelerates for the time set in  $L2-10$ , the drive measures the DC bus voltage and the status of the digital input set for KEB Ride-Thru. When the DC bus voltage is less than the level set in  $L2-11$ , or if the digital input set to KEB Ride-Thru is active, deceleration continues. When the DC bus voltage is more than the level set in  $L2-11$ , the drive ends KEB operation. The drive accelerates the motor to the frequency reference value before the power loss, and usual operation continues. When the KEB Ride-Thru continues to be input after the time set in  $L2-02$  is expired, the drive uses the KEB Ride-Thru function to continue to decelerate. When you cancel the KEB Ride-Thru, the motor accelerates again, and usual operation continues.



**Figure 2.127 Use the KEB Ride-Thru to Cancel KEB Operation when Restoration of Power Occurs while the Control Power (Power Supply to the Control Board) is Maintained**

\*1 When  $L2-07 = 0.00\text{ s}$ , the drive accelerates again as specified by the applicable *Acceleration Time* [ $C1-01$ ,  $C1-03$ ,  $C1-05$ ,  $C1-07$ ], and usual operation continues.

#### KEB Operation when $L2-01 = 5$ [Kinetic Energy Backup: DecelStop]

The drive starts deceleration through KEB operation. If you do not input the Run command, the motor cannot restart. The drive will continue to decelerate until the motor comes to the minimum output frequency or a complete stop. If you return power during deceleration, the drive continues to decelerate.

#### ■ KEB Operation Wiring Example

Figure 2.128 shows an example that uses an undervoltage relay to trigger the KEB Ride-Thru at power loss. When a power loss occurs, the undervoltage relay triggers *KEB Ride-Thru* [ $H1-06 = 65, 66, 7A, 7B$ ] at terminal S6.

##### Note:

- Configure the settings so that the Run command turns ON while the KEB function is working. If you turn off the Run command, the drive will not accelerate back to speed when you return power.
- A dynamic braking option is necessary for *System KEB Ride-Thru 1* [ $L2-29 = 2$ ].

## 2.9 L: Protection Functions

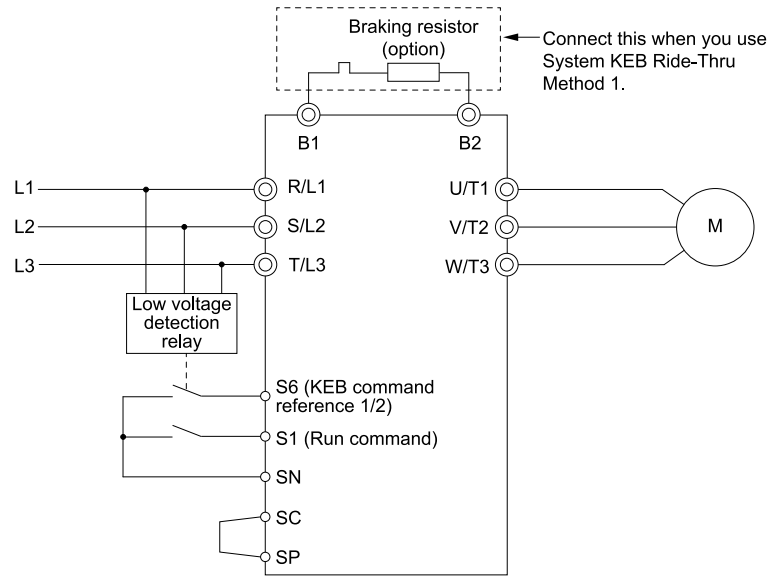


Figure 2.128 KEB Function Wiring Example

### Parameters for KEB Ride-Thru

Table 2.67 shows the parameters that adjust the KEB Ride-Thru function. Parameter settings are different for the different KEB methods set in L2-29 [Kinetic Energy Backup Method].

Table 2.67 Parameters for KEB Ride-Thru

| No.   | Name                             | Configuring Settings   | L2-29 [Kinetic Energy Backup Method] |   |      |      |
|-------|----------------------------------|--|--------------------------------------|---|------|------|
|       |                                  |  | 0                                    | 1 | 2    | 3    |
| C1-09 | Fast Stop Time                   | <ul style="list-style-type: none"> <li>If <i>ov</i> [Overvoltage] occurs during KEB deceleration, increase the setting value.</li> <li>If <i>Uv1</i> [DC Bus Undervoltage] occurs during KEB deceleration, decrease the setting value.</li> </ul>  | x *1                                 | - | -    | -    |
| C2-03 | S-Curve Time @ Start of Decel    | <ul style="list-style-type: none"> <li>If <i>ov</i> occurs immediately after you start KEB deceleration, increase the setting value.</li> <li>If <i>Uv1</i> occurs immediately after you start KEB deceleration, decrease the setting value.</li> </ul>  | x                                    | - | x    | x    |
| L2-05 | Undervoltage Detection Lvl (Uv1) | If <i>Uv1</i> occurs immediately after you start KEB deceleration, increase the setting value to detect power loss more quickly.   | x                                    | x | x    | x    |
| L2-06 | Does KEB Tuning.                 | <ul style="list-style-type: none"> <li>Kinetic Energy Backup Decel Time</li> <li>If <i>ov</i> or <i>Uv1</i> occur during KEB deceleration after the KEB Tuning, set L2-06 as follows: <ul style="list-style-type: none"> <li>If <i>ov</i> occurs, increase the setting value</li> <li>If <i>Uv1</i> occurs, decrease the setting value.</li> </ul> </li> </ul>                       | -                                    | - | x *2 | x *2 |
| L2-07 | Kinetic Energy Backup Accel Time | Sets the acceleration time to return to the frequency reference value before a power loss, after you cancel the KEB operation. When L2-07 = 0, the drive uses standard acceleration times set in C1-01, C1-03, C1-05, and C1-07 [Acceleration Time].   | x                                    | x | x    | x    |
| L2-08 | Frequency Gain at KEB Start      | <ul style="list-style-type: none"> <li>If <i>ov</i> occurs immediately after you start operation, decrease the setting value.</li> <li>If <i>Uv1</i> occurs immediately after you start operation, increase the setting value.</li> </ul>  | x                                    | - | x    | x    |
| L2-10 | Minimum KEB Time                 | <ul style="list-style-type: none"> <li>With KEB Ride-Thru<br/>There is <i>Uv1</i> because you set a digital input for KEB Ride-Thru and the device that controls the input operated too slowly after power loss.</li> <li>Without KEB Ride-Thru<br/>If the DC bus voltage overshoots immediately after KEB Ride-Thru starts, increase L2-10 to longer than the overshoot.</li> </ul> | x                                    | x | x    | x    |
| L2-11 | KEB DC Bus Voltage Setpoint      | <ul style="list-style-type: none"> <li>Single Drive KEB Ride-Thru 2<br/>Set to approximately 1.22 x input voltage.</li> <li>Single Drive KEB Ride-Thru 1, System KEB Ride-Thru 1, or System KEB Ride-Thru 2<br/>Set to approximately 1.4 x input voltage.</li> </ul>   | x                                    | x | x    | x    |
| L3-20 | DC Bus Voltage Adjustment Gain   | <ul style="list-style-type: none"> <li>If <i>ov</i> or <i>Uv1</i> occurs at the start of deceleration when you use KEB operation, increase this value in 0.1 unit increments.</li> <li>If there is torque ripple during deceleration when you use KEB Ride-Thru, decrease the value.</li> </ul>  | -                                    | x | -    | -    |

| No.   | Name                              | Configuring Settings   | L2-29 [Kinetic Energy Backup Method] |      |   |   |
|-------|-----------------------------------|--|--------------------------------------|------|---|---|
|       |                                   |  | 0                                    | 1    | 2 | 3 |
| L3-21 | OVSUPPRESSION ACCEL/DECCEL P GAIN | If there is large speed or current ripple, decrease the value in 0.05 unit increments.<br><b>Note:</b><br>If the setting value is too low, then the drive will have unsatisfactory DC bus voltage control response. The drive can detect <i>ov</i> or <i>Uv1</i> . | -                                    | x    | - | - |
| L3-24 | MOTOR ACCEL TIME FOR INERTIA CAL  | Set the motor acceleration time to the maximum frequency at the motor rated torque.  | -                                    | x    | - | - |
| L3-25 | LOAD INERTIA RATIO                | Sets the ratio between motor inertia and machine inertia.  | -                                    | x *3 | - | - |

- \*1 When L2-29 = 0 [Kinetic Energy Backup Method = Single Drive KEB Ride-Thru 1] and you do KEB Auto-Tuning, the drive will automatically set C1-09. If you must not change the Fast Stop time, do not do KEB Tuning.
- \*2 If you do KEB Tuning when L2-29 = 1, 2, or 3 [Kinetic Energy Backup Method = Single Drive KEB Ride-Thru 2, System KEB Ride-Thru 1, or System KEB Ride-Thru 2], the drive will automatically set L2-06 [Kinetic Energy Backup Decel Time].
- \*3 The drive sets this value automatically when KEB Tuning completes correctly.

### ■ L2-01: Power Loss Ride Through Select

| No. (Hex.)   | Name                           | Description  | Default (Range) |
|--------------|--------------------------------|--|-----------------|
| L2-01 (0485) | Power Loss Ride Through Select | <b>V/f</b> <b>CL-V/f</b> <b>OLV</b> <b>CLV</b> <b>AOLV</b> <b>OLV/PM</b> <b>AOLV/PM</b> <b>CLV/PM</b> <b>EZOLV</b><br>Sets the drive operation after a momentary power loss. | 0 (0 - 5)       |

The drive detects momentary power loss when the drive DC bus voltage is less than the value set in L2-05 [Undervoltage Detection Lvl (Uv1)].

#### 0 : No

*Uv1* [DC Bus Undervoltage] is detected when a momentary power loss occurs.

If power is not restored within 15 ms, a *Uv1* is triggered and the drive shuts off the output. The motor coasts to stop.

#### 1 : Yes

When power returns in the time set in L2-02 [Power Loss Ride Through Time], the drive will restart. If power does not return in the time set in L2-02, the drive will detect *Uv1*.

The drive momentarily turns OFF its output after a power loss. If the power returns in the time set to L2-02, the drive will do Speed Search and try to continue operation.

If the DC bus voltage is less than or equal to the *Uv1* detection level for the time set in L2-02, the drive will detect *Uv1* and output a fault signal.

#### Note:

- The necessary time for the drive to restart after power returns is different for different drive capacities.
- The upper limit of the possible momentary power loss Ride-Thru time is different for different drive models.

#### 2 : Enabled while CPU Power Active

When power returns and the drive control circuit has power, the drive will restart. This will not trigger *Uv1*.

When there is a momentary power loss, the drive output will turn OFF. If the power returns and the drive control circuit has power, the drive will do Speed Search and try to continue operation. This will not trigger a *Uv1*. This function enables longer support for power loss than using L2-01 = 1.

#### 3 : Kinetic Energy Backup

If power does not return in the time set in L2-02, the drive will detect *Uv1*.

If the drive detects momentary power loss, the drive will use regenerative energy from the motor and ramp to stop. When you return power in the time set in L2-02, the drive will accelerate to the frequency reference value that was used before the power loss. If you do not return power in the time set to L2-02, the drive will detect *Uv1* and the drive output will turn OFF. L2-29 [Kinetic Energy Backup Method] sets the type of KEB operation.

#### 4 : Kinetic Energy Backup: CPU Power

When power returns and the drive control circuit has power, the drive will restart.

The drive decelerates using regenerative energy from the motor until the power returns and then restarts when a momentary power loss is detected. When power is restored during deceleration, the drive accelerates the motor again to the frequency reference value used before the power loss. If the motor comes to a stop before the power returns, the

## 2.9 L: Protection Functions

drive loses control power and the drive output shuts off. A *UvI* is not triggered when power is restored while power to the CPU in the drive is maintained. *L2-29* sets the type of KEB operation.

### 5 : Kinetic Energy Backup: DecelStop

When power returns, the drive will continue to decelerate until the motor fully stops.

If the drive detects momentary power loss, the drive will use regenerative energy from the motor and ramp to stop. When you return power to the drive, the drive will continue to decelerate until the motor comes to a full stop. After you return power, the drive will ramp to stop in the set deceleration time. *L2-29* sets the type of KEB operation.

#### Note:

When you set *L2-01*, make sure that you know these items:

- You can use a Momentary Power Loss Unit on models 2004 to 2056 and 4002 to 4031 for a longer momentary power loss ride through time. A Momentary Power Loss Unit makes it possible to continue operation of the drive after a maximum of 2 seconds of power loss.
- When you set *L2-01* = 1 to 4, keep the magnetic contactor on the drive input side closed and keep the control signal while the drive does KEB operation.
- When *L2-01* = 1 to 5, *Uv* [DC Bus Undervoltage] will flash on the keypad while the drive is attempting to recover from a momentary power loss. The drive will not output a fault signal at this time.
- When you use a magnetic contactor between the motor and the drive, keep the magnetic contactor closed while the drive does KEB operation or tries to restart with Speed Search.
- Keep the Run command active during KEB operation. The drive cannot accelerate back to the frequency reference when the power returns.
- When you set *L2-01* = 3 to 5, if the control power supply voltage is less than the CPU operation level during KEB Ride-Thru, it will trigger *UvI*.

### ■ L2-02: Power Loss Ride Through Time

| No. (Hex.)   | Name                         | Description  | Default (Range)                           |
|--------------|------------------------------|--|---|
| L2-02 (0486) | Power Loss Ride Through Time | <input type="checkbox"/> V/f <input type="checkbox"/> CL-V/f <input type="checkbox"/> OLV <input type="checkbox"/> CLV <input type="checkbox"/> AOLV <input type="checkbox"/> OLV/PM <input type="checkbox"/> AOLV/PM <input type="checkbox"/> CLV/PM <input type="checkbox"/> EZOLV<br>Sets the maximum time that the drive will wait until trying to restart after power loss. | Determined by o2-04, C6-01 (0.0 - 25.5 s) |

This function is applicable when *L2-01* = 1, 3 [*Power Loss Ride Through Select* = Enabled for *L2-02* Time, Kinetic Energy Backup: *L2-02*]. If power loss operation is longer than the time set in this parameter, the drive will detect *UvI* [DC Bus Undervoltage], turn OFF output, and the motor will coast to stop.

#### Note:

- The length of time that the drive can recover after a power loss changes when drive capacity changes.
- The upper limit of the possible momentary power loss Ride-Thru time changes when drive capacity changes.

### ■ L2-03: Minimum Baseblock Time

| No. (Hex.)   | Name                   | Description  | Default (Range)                          |
|--------------|------------------------|--|--|
| L2-03 (0487) | Minimum Baseblock Time | <input type="checkbox"/> V/f <input type="checkbox"/> CL-V/f <input type="checkbox"/> OLV <input type="checkbox"/> CLV <input type="checkbox"/> AOLV <input type="checkbox"/> OLV/PM <input type="checkbox"/> AOLV/PM <input type="checkbox"/> CLV/PM <input type="checkbox"/> EZOLV<br>Sets the minimum time to continue the drive output block (baseblock) after a previous baseblock. | Determined by o2-04, C6-01 (0.1 - 5.0 s) |

Sets the length of time that the drive will wait for the residual voltage in the motor to dissipate in estimation to the secondary circuit time constant of the motor. Increase this setting if an *oC* [Overcurrent] or *ov* [DC Bus Overvoltage] occurs at the beginning of Speed Search, after power returns, or during DC Injection Braking.

### ■ L2-04: Powerloss V/f Recovery Ramp Time

| No. (Hex.)   | Name                             | Description   | Default (Range)                          |
|--------------|----------------------------------|---|--|
| L2-04 (0488) | Powerloss V/f Recovery Ramp Time | <input type="checkbox"/> V/f <input type="checkbox"/> CL-V/f <input type="checkbox"/> OLV <input type="checkbox"/> CLV <input type="checkbox"/> AOLV <input type="checkbox"/> OLV/PM <input type="checkbox"/> AOLV/PM <input type="checkbox"/> CLV/PM <input type="checkbox"/> EZOLV<br>Sets the time for the drive output voltage to go back to correct voltage after completing speed searches. | Determined by o2-04, C6-01 (0.0 - 5.0 s) |

Sets the time for voltage to recover from 0 V to the value set in *E1-05* [Maximum Output Voltage].

■ L2-05: Undervoltage Detection Lvl (Uv1)

| No. (Hex.)   | Name                             | Description  | Default (Range)   |
|--------------|----------------------------------|--|---|
| L2-05 (0489) | Undervoltage Detection Lvl (Uv1) | <span>V/f</span> <span>CL-V/f</span> <span>OLV</span> <span>CLV</span> <span>AOLV</span> <span>OLV/PM</span> <span>AOLV/PM</span> <span>CLV/PM</span> <span>EZOLV</span><br>Sets the voltage at which a <i>Uv1</i> [DC Bus Undervoltage] fault is triggered or at which the KEB function is activated. Usually it is not necessary to change this setting. | Determined by o2-04 and E1-01<br>(200 V Class: 150 - 210 V, 400 V Class: 300 - 420 V) |

**NOTICE: Damage to Equipment.** When you set this parameter to a value lower than the default, you must install an AC reactor on the input side of the power supply. If you do not install an AC reactor, it will cause damage to the drive circuitry.

**Note:**

If the low voltage detection level is near the lower limit value of *L2-05*, the drive will detect *Uv1* during KEB Ride-Thru operation. Do not set the value too low when you use the KEB Ride-Thru function.

■ L2-06: Kinetic Energy Backup Decel Time

| No. (Hex.)          | Name             | Description   | Default (Range)           |
|---------------------|------------------|---|---------------------------|
| L2-06 (048A) Expert | Does KEB Tuning. | <span>V/f</span> <span>CL-V/f</span> <span>OLV</span> <span>CLV</span> <span>AOLV</span> <span>OLV/PM</span> <span>AOLV/PM</span> <span>CLV/PM</span> <span>EZOLV</span><br>Sets the deceleration time during KEB operation used to decrease the maximum output frequency to 0. | 0.0 s<br>(0.0 - 6000.0 s) |

Set *L2-29* = 2 or 3 [Kinetic Energy Backup Method = System KEB Ride-Thru 1 or System KEB Ride-Thru 2] to enable this function. When *L2-29* = 1, 2, 3 [Kinetic Energy Backup Method = Single Drive KEB Ride-Thru 2, System KEB Ride-Thru 1, System KEB Ride-Thru 2] and you do KEB Auto-Tuning, the drive will automatically set this value.

Sets the deceleration time necessary to decelerate from the frequency reference to 0 Hz when the drive detects a momentary power loss. If a *Uv1* [DC Bus Undervoltage] fault occurs during KEB operation, decrease the deceleration time. If an *ov* [Overvoltage] fault occurs, increase the deceleration time.

- *L2-06* = 0

The drive automatically decreases *C1-09* [Fast Stop Time] to the base value to keep the DC bus voltage above the low voltage detection level. The drive ignores *L2-02* [Momentary Power Loss Ride-Thru Time] in this condition.

- *L2-06* ≠ 0

As shown in Figure 2.129, the frequency reference decelerates to the KEB frequency level as specified by the deceleration rate set in *L2-06* and then returns to the initial frequency reference as specified by *C1-01* [Acceleration Time 1]. The drive uses the setting value of the KEB frequency rate as shown in the this formula to set the KEB frequency level:

$$\text{KEB frequency level} = \text{Output frequency before power loss} \times (1 - (L2-02) / (L2-06))$$

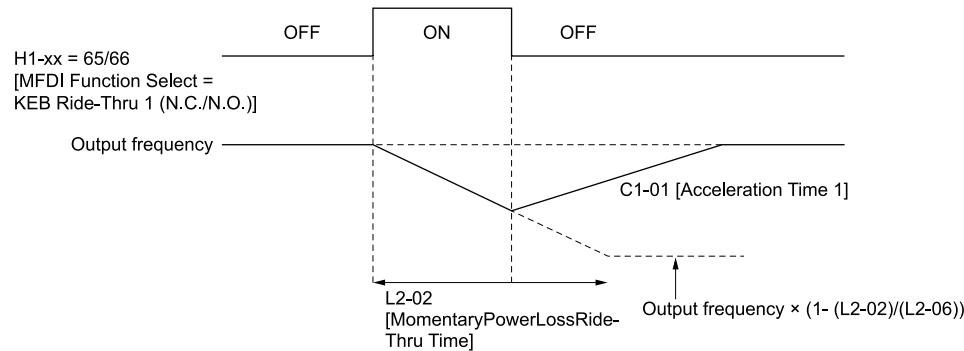


Figure 2.129 Kinetic Energy Backup Decel Time

■ L2-07: Kinetic Energy Backup Accel Time

| No. (Hex.)          | Name                             | Description  | Default (Range)           |
|---------------------|----------------------------------|--|---------------------------|
| L2-07 (048B) Expert | Kinetic Energy Backup Accel Time | <span>V/f</span> <span>CL-V/f</span> <span>OLV</span> <span>CLV</span> <span>AOLV</span> <span>OLV/PM</span> <span>AOLV/PM</span> <span>CLV/PM</span> <span>EZOLV</span><br>Sets the acceleration time to return the frequency to the frequency reference before a power loss after canceling KEB operation. | 0.0 s<br>(0.0 - 6000.0 s) |

Parameter Details

## 2.9 L: Protection Functions

Set this parameter to 0.0 to disable the function. The drive uses the acceleration time in *C1-01*, *C1-03*, *C1-05*, and *C1-07* to accelerate again after KEB operation completes.

### ■ L2-08: Frequency Gain at KEB Start

| No. (Hex.)                | Name                        | Description   | Default (Range)    |
|---------------------------|-----------------------------|---|--------------------|
| L2-08<br>(048C)<br>Expert | Frequency Gain at KEB Start | <div style="display: flex; gap: 5px;"> <span>V/f</span> <span>CL-V/f</span> <span>OLV</span> <span>CLV</span> <span>AOLV</span> <span>OLV/PM</span> <span>AOLV/PM</span> <span>CLV/PM</span> <span>EZOLV</span> </div> <p>Sets the quantity of output frequency reduction used when KEB operation starts as a percentage of the motor rated slip before starting KEB operation.</p> | 100%<br>(0 - 300%) |

Decreases the output frequency in steps to quickly set the motor to a regenerative condition. Use this formula to calculate the value:

$$\text{Output frequency reduction} = \text{Motor rated slip before KEB operation} \times (L2-08/100) \times 2$$

### ■ L2-09: KEB Minimum Frequency Level

| No. (Hex.)                | Name                        | Description  | Default (Range)   |
|---------------------------|-----------------------------|--|-------------------|
| L2-09<br>(048D)<br>Expert | KEB Minimum Frequency Level | <div style="display: flex; gap: 5px;"> <span>V/f</span> <span>CL-V/f</span> <span>OLV</span> <span>CLV</span> <span>AOLV</span> <span>OLV/PM</span> <span>AOLV/PM</span> <span>CLV/PM</span> <span>EZOLV</span> </div> <p>Sets the quantity of output frequency reduction used when KEB operation starts as a percentage of <i>E2-02</i> [Motor Rated Slip].</p> | 20%<br>(0 - 100%) |

These conditions set the quantity of decrease:

- Motor rated slip  $\times (L2-09/100)$
- The larger value between the value calculated with *L2-08* and the value calculated with *L2-09*

### ■ L2-10: Minimum KEB Time

| No. (Hex.)                | Name             | Description  | Default (Range)         |
|---------------------------|------------------|--|-------------------------|
| L2-10<br>(048E)<br>Expert | Minimum KEB Time | <div style="display: flex; gap: 5px;"> <span>V/f</span> <span>CL-V/f</span> <span>OLV</span> <span>CLV</span> <span>AOLV</span> <span>OLV/PM</span> <span>AOLV/PM</span> <span>CLV/PM</span> <span>EZOLV</span> </div> <p>Sets the minimum length of time to operate the KEB after the drive detects a momentary power loss.</p> | 50 ms<br>(0 - 25500 ms) |

When you return power while KEB is operating, the drive continues KEB operation until the time set in *L2-10* is expired. When the DC bus voltage is less than the level of *L2-05* [Undervoltage Detect Level (*Uv1*)] in one of these conditions, KEB operation continues until the time set in *L2-10* is expired:

- *L2-01* = 3 [Momentary Power Loss Ope Select = KEB Mode].
- *L2-01* = 4 [KEB Stop Mode]
- *L2-01* = 5 [KEB Decel to Stp].
- KEB Ride-Thru 1/2 [*H1-xx* = 65, 66, 7A, or 7B] is input into the drive.

When you input KEB Ride-Thru, KEB operation continues after the time set in *L2-10* is expired. When you cancel KEB Ride-Thru, the motor accelerates again. When you do not input KEB Ride-Thru during the time set in *L2-10*, the drive accelerates to the frequency reference that the drive had before power loss in the applicable acceleration time.

When *L2-01* = 3, 4, or 5, and the DC bus voltage is a minimum of the value of *L2-11* [DC Bus Vol Setpoint during KEB], the drive accelerates again after the time set in *L2-10* is expired. If the DC bus voltage is less than the *L2-11* value, KEB operation continues after the time set in *L2-10* is expired.

**Note:**

- When *L2-01* = 0, 1, or 2 [Disabled, Enabled, or Enabled when CPU is Running], increase the value of *L2-10*. Set *L2-10* to cancel KEB operation if the KEB Ride-Thru is not input
- Set this parameter to 0 to disable the function.

### ■ L2-11: KEB DC Bus Voltage Setpoint

| No. (Hex.)                | Name                        | Description   | Default (Range)                              |
|---------------------------|-----------------------------|---|--|
| L2-11<br>(0461)<br>Expert | KEB DC Bus Voltage Setpoint | <b>V/f</b> <b>CL-V/f</b> <b>OLV</b> <b>CLV</b> <b>AOLV</b> <b>OLV/PM</b> <b>AOLV/PM</b> <b>CLV/PM</b> <b>EZOLV</b><br>Sets the target value that controls the DC bus voltage to a constant level in Single Drive KEB Ride-Thru 2. Sets the DC bus voltage level that completes the KEB operation for all other KEB methods. | Determined by E1-01<br>(Determined by E1-01) |

### ■ L2-29: Kinetic Energy Backup Method

| No. (Hex.)                | Name                         | Description   | Default (Range) |
|---------------------------|------------------------------|---|-----------------|
| L2-29<br>(0475)<br>Expert | Kinetic Energy Backup Method | <b>V/f</b> <b>CL-V/f</b> <b>OLV</b> <b>CLV</b> <b>AOLV</b> <b>OLV/PM</b> <b>AOLV/PM</b> <b>CLV/PM</b> <b>EZOLV</b><br>Sets the KEB function operation mode. | 0<br>(0 - 3)    |

Set *L2-01* = 3, 4, or 5 [*Momentary Power Loss Ope Select* = *KEB Mode*, *KEB Stop Mode*, or *KEB Decel to Stp*] or *KEB Ride-Thru 1/2* [*H1-xx* = 65, 66, 7A, or 7B], to enable the KEB function.

#### 0 : Single Drive KEB Ride-Thru 1

The drive monitors the DC bus voltage and uses regenerative energy from the motor to hold the DC bus voltage at the level set in *L2-11* [*KEB DC Bus Voltage Setpoint*].

The KEB operation continues and the deceleration rate changes as specified by *C1-09* [*Fast Stop Time*].

**Note:**

- If the drive detects *Uv1* [*DC Bus Undervoltage*] during KEB operation, decrease the value of *C1-09*.
- If the drive detects *ov* [*Overvoltage*] during KEB operation, increase the value of *C1-09*.

#### 1 : Single Drive KEB Ride-Thru 2

The drive does KEB operation and automatically calculates the deceleration rate to make sure that the main circuit electrical energy and main current voltage from motor regenerative energy is equal to *L2-11* [*DC Bus Vol Setpoint during KEB*].

#### 2 : System KEB Ride-Thru 1

The drive does not monitor the DC bus voltage and decelerates as specified by the KEB deceleration time set in *L2-06*.

Set *L2-06* to the time necessary to decelerate from the frequency reference to 0 Hz when the drive detects a momentary power loss. The drive can decelerate and keep constant deceleration rates for more than one drive.

**Note:**

If you keep constant deceleration rates for more than one drive, it can trigger *ov* faults. Use the dynamic braking option with System KEB Ride-Thru 1 to prevent *ov* faults.

#### 3 : System KEB Ride-Thru 2

The drive monitors the DC bus voltage and decelerates for the deceleration time set in *L2-06*.

If the DC bus voltage increases, the drive momentarily holds the frequency to prevent *ov* while deceleration continues.

**Note:**

When you cannot use a dynamic braking option, use System KEB Ride-Thru.

### ■ L2-30: KEB Zero Speed Operation

| No. (Hex.)                | Name                     | Description  | Default (Range) |
|---------------------------|--------------------------|--|-----------------|
| L2-30<br>(045E)<br>Expert | KEB Zero Speed Operation | <b>V/f</b> <b>CL-V/f</b> <b>OLV</b> <b>CLV</b> <b>AOLV</b> <b>OLV/PM</b> <b>AOLV/PM</b> <b>CLV/PM</b> <b>EZOLV</b><br>Sets the operation when the output frequency decreases below the zero level (DC braking injection starting frequency) during KEB deceleration when <i>L2-01</i> = 3 to 5 [ <i>Power Loss Ride Through Select</i> = <i>Kinetic Energy Backup</i> : <i>L2-02</i> , <i>Kinetic Energy Backup</i> : <i>CPU Power</i> , or <i>Kinetic Energy Backup</i> : <i>DecelStop</i> ]. | 0<br>(0, 1)     |

#### 0 : Baseblock

#### 1 : DC/SC Braking

## 2.9 L: Protection Functions

Does DC injection braking and short circuit braking as specified by *b2-04 [DC Inject Braking Time at Stop]* and *b2-13 [Short Circuit Brake Time @ Stop]*.

### ■ L2-31: KEB Start Voltage Offset Level

| No. (Hex.)             | Name                           | Description  | Default (Range)   |
|------------------------|--------------------------------|--|---|
| L2-31 (045D)<br>Expert | KEB Start Voltage Offset Level | <div style="display: flex; gap: 5px;"> <span>V/f</span> <span>CL-V/f</span> <span>OLV</span> <span>CLV</span> <span>AOLV</span> <span>OLV/PM</span> <span>AOLV/PM</span> <span>CLV/PM</span> <span>EZOLV</span> </div> <p>Sets the KEB start voltage offset.</p> | Determined by A1-02<br>(200 V Class: 0 - 100 V, 400 V Class: 0 - 200 V) |

The drive uses this formula to calculate the KEB start voltage:

$$\text{KEB start voltage} = L2-05 [\text{Undervoltage Detect Level (Uv1)}] + L2-31$$

## ◆ L3: Stall Prevention

*L3 parameters* set the Stall Prevention function and overvoltage suppression function.

### ■ Stall Prevention

If the load is too heavy or the acceleration and deceleration times are too short, the motor can slip too much because it cannot work at the same rate as the frequency reference. If the motor stalls during acceleration, current increases as the slip increases to cause an *oC [Overcurrent]*, *oL2 [Drive Overload]*, or *oL1 [Motor Overload]* and the drive will stop. If the motor stalls during deceleration, too much regenerative power will flow back into the DC bus capacitors, and cause the drive to fault out from *ov [Overvoltage]* and the drive will stop.

The stall prevention function will let the motor get to the set speed without stalling and it is not necessary for you to change the acceleration or deceleration time settings. You can set a separate stall prevention functions for acceleration, operating at constant speeds, and deceleration.

### ■ Overvoltage Suppression Function

Decreases the regenerative torque limit and increases the output frequency when the DC bus voltage increases to prevent *ov*. This function can drive loads with cyclic regenerative operation, for example punch presses or other applications with repeated crank movements. When you use this function, set *L3-11 = 1 [Overvoltage Suppression Select = Enabled]*.

The drive adjusts the regenerative torque limit and the output frequency during overvoltage suppression to make sure that the DC bus voltage is not more than the level set in *L3-17 [DC Bus Regulation Level]*.

Set these parameters as necessary when you use the overvoltage suppression function:

- *L3-20 [DC Bus Voltage Adjustment Gain]*
- *L3-21 [OVSuppression Accel/Decel P Gain]*
- *L3-24 [Motor Accel Time @ Rated Torque]*
- *L3-25 [Load Inertia Ratio]*

**Note:**

- When overvoltage suppression is triggered, the motor speed is more than the frequency reference. Do not use overvoltage suppression for applications where the frequency reference and the motor speed must align.
- When you use a braking resistor, set *L3-11 = 0 [Disabled]*.
- The overvoltage suppression function is enabled only when you operate immediately below the maximum frequency. Overvoltage suppression does not increase the output frequency to more than the maximum frequency. Make sure that the motor and machine specifications are correct for the application, then increase the maximum frequency.
- If there is a sudden increase to a regenerative load, *ov* can occur.

### ■ L3-01: Stall Prevention during Accel

| No. (Hex.)   | Name                          | Description  | Default (Range) |
|--------------|-------------------------------|--|-----------------|
| L3-01 (048F) | Stall Prevention during Accel | <div style="display: flex; gap: 5px;"> <span>V/f</span> <span>CL-V/f</span> <span>OLV</span> <span>CLV</span> <span>AOLV</span> <span>OLV/PM</span> <span>AOLV/PM</span> <span>CLV/PM</span> <span>EZOLV</span> </div> <p>Sets the method of the Stall Prevention During Acceleration.</p> | 1<br>(0 to 3)   |



**Note:**

When  $A1-02 = 5$  [Control Method Selection = OLV/PM], the setting range is 0 and 1.

Stall prevention during acceleration prevents the stalling and stopping of motors when  $oC$  [Overcurrent],  $oL2$  [Drive Overloaded], or  $oL1$  [Motor Overload] is detected in cases of significant loads applied during acceleration or sudden acceleration times regarding load inertia are set.

**0 : No**

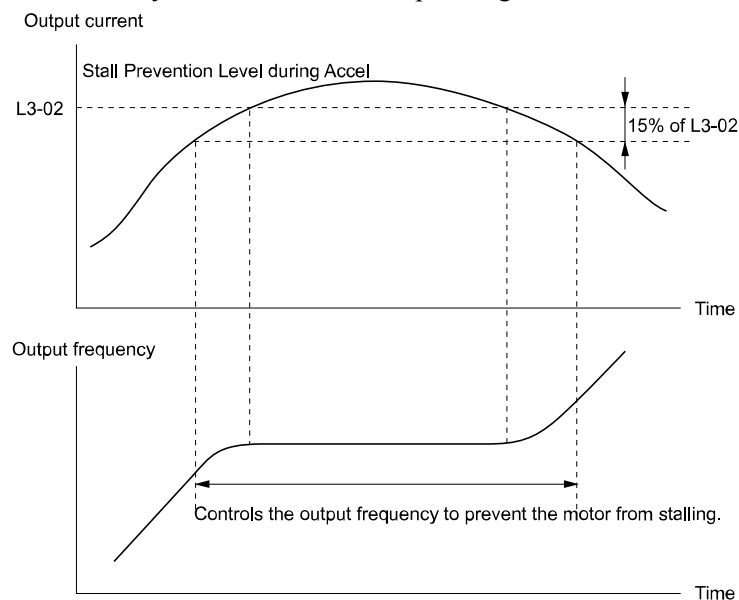
The Stall Prevention function does not operate during acceleration, and acceleration occurs for the set acceleration time. If the acceleration time is too short, the motor does not fully accelerate during the set time, which causes the drive to detect  $oL1$  or  $oL2$  and the motor to stop.

**1 : Yes**

Enables the Stall Prevention During Acceleration function. Operation is different for different control methods.

- **V/f Control, Open Loop Vector Control, or EZ Open Loop Vector Control**

When the output current is more than the value set in  $L3-02$  [Stall Prevent Level during Accel], the drive stops acceleration. Deceleration is stopped once the output current falls below the value set in  $L3-02 - 15\%$ . The Stall Prevention function level automatically falls for constant output ranges.



**Figure 2.130 Stall Prevention During Acceleration when Using Induction Motors**

- **Open Loop Vector Control for PM**

When the output current is more than the value set in  $L3-02$ , the drive stops acceleration. When the time set in  $L3-27$  [Stall Prevention Detection Time] is expired and the output current is larger than the value set in  $L3-02$ , the drive will start deceleration in as specified by the value set in  $L3-22$  [PM Stall Prevention Decel Time]. The drive starts acceleration again once the output current falls below the value set in  $L3-02 - 15\%$ . When the time set in  $L3-27$  is expired, the drive starts acceleration again.

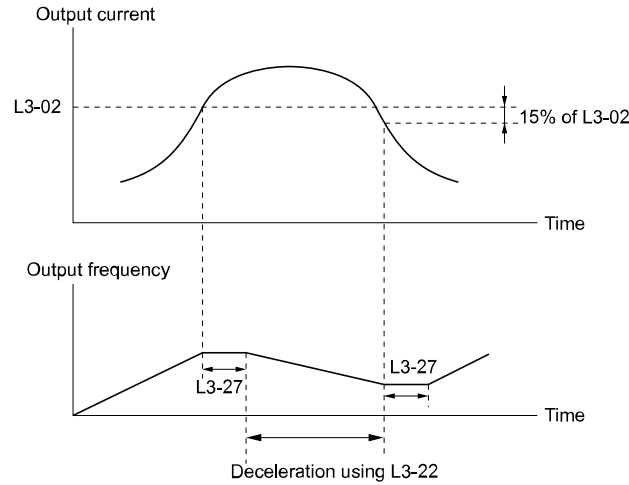


Figure 2.131 Stall Prevention During Acceleration Function in OLV/PM

**2 : Intelligent (Ignore Decel Ramp)**

The drive ignores the acceleration time setting and the drive starts to accelerate in the minimum length of time. The acceleration rate is automatically adjusted so that the output current does not exceed the value set in L3-02.

**3 : Current Limit Acceleration**

This function limits the output current with the value set for L3-02 and automatically adjusts the acceleration rate. When the load (output current) increases to more than the current limit level during acceleration, the drive automatically adjusts the acceleration rate.

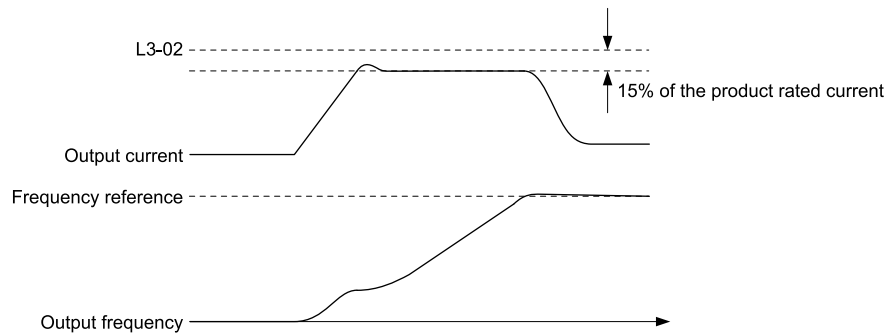


Figure 2.132 Current Limit Acceleration

■ **L3-02: Stall Prevent Level during Accel**

| No. (Hex.)   | Name                             | Description   | Default (Range)                          |
|--------------|----------------------------------|---|--|
| L3-02 (0490) | Stall Prevent Level during Accel | <input checked="" type="checkbox"/> V/f <input checked="" type="checkbox"/> CL-V/f <input checked="" type="checkbox"/> OLV <input type="checkbox"/> CLV <input type="checkbox"/> AOLV <input checked="" type="checkbox"/> OLV/PM <input type="checkbox"/> AOLV/PM <input type="checkbox"/> CLV/PM <input checked="" type="checkbox"/> EZOLV<br>Sets the output current level to activate the Stall Prevention function during acceleration as a percentage of the drive rated output current. | Determined by C6-01 and L8-38 (0 - 150%) |

**Note:**

- If you use a motor that is small compared to the drive and the motor stalls, decrease the setting value.
- When you operate the motor in the constant power range, set L3-03 [Stall Prevent Limit during Accel].
- The upper limit of the setting range changes when the setting for C6-01 [Normal / Heavy Duty Selection] changes.
  - 150% when C6-01 = 0 [Heavy Duty Rating 1 (HD1) for Constant Torque Applications].
  - 110% when C6-01 = 1 [Normal Duty Rating 1 (ND1) for Variable Torque Applications].

■ **L3-03: Stall Prevent Limit during Accel**

| No. (Hex.)   | Name                             | Description   | Default (Range) |
|--------------|----------------------------------|---|-----------------|
| L3-03 (0491) | Stall Prevent Limit during Accel | <input checked="" type="checkbox"/> V/f <input checked="" type="checkbox"/> CL-V/f <input checked="" type="checkbox"/> OLV <input type="checkbox"/> CLV <input type="checkbox"/> AOLV <input checked="" type="checkbox"/> OLV/PM <input type="checkbox"/> AOLV/PM <input type="checkbox"/> CLV/PM <input checked="" type="checkbox"/> EZOLV<br>Sets the lower limit for the stall prevention level used in the constant output range as a percentage of the drive rated output current. | 50% (0 - 100%)  |

The stall prevention level set in L3-02 [Stall Prevent Level during Accel] is automatically reduced when the motor is running within the constant output range. Parameter L3-03 is the limit value used to prevent the stall prevention level during constant output ranges to fall below the minimum required level.

**Note:**

The function to automatically reduce the stall prevention level does not operate when L3-01 = 3 [Stall Prevention during Accel = Current Limit Method].

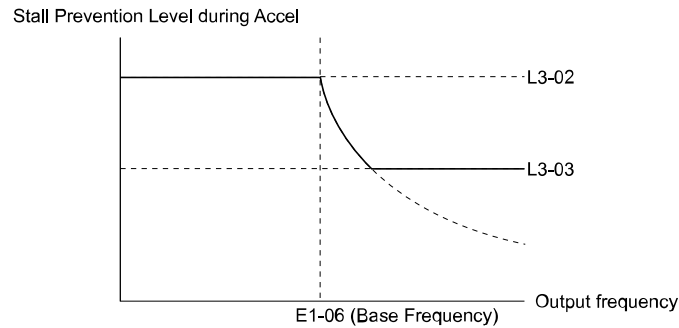


Figure 2.133 Stall Prevent Level during Accel/Limit

■ L3-04: Stall Prevention during Decel

| No. (Hex.)   | Name                          | Description  | Default (Range)            |
|--------------|-------------------------------|--|----------------------------|
| L3-04 (0492) | Stall Prevention during Decel | <span>V/f</span> <span>CL-V/f</span> <span>OLV</span> <span>CLV</span> <span>AOLV</span> <span>OLV/PM</span> <span>AOLV/PM</span> <span>CLV/PM</span> <span>EZOLV</span><br>Sets the method that the drive will use to prevent overvoltage faults when decelerating. | 1<br>(Determined by A1-02) |

**Note:**

- To connect a dynamic braking option (braking resistor or braking resistor unit) to the drive, set this parameter to 0 or 3. Parameter values 1, 2, 4, and 5 will enable Stall Prevention function during deceleration, and the dynamic braking option will not function.
- The setting range changes when the A1-02 [Control Method Selection] value changes:
  - When A1-02 = 5 [OLV/PM], the setting range is 0 to 2.
  - When A1-02 = 6, 7, 8 [AOLV/PM, CLV/PM, EZOLV], the setting range is 0, 1.

Stall Prevention during deceleration controls the deceleration as specified by the DC bus voltage and does not let high inertia or fast deceleration cause ov [Overvoltage] faults.

**0 : No**

The drive decelerates as specified by the deceleration time. If the deceleration time is too short, the drive can detect an ov fault.

**Note:**

If an ov fault occurs, connect a dynamic braking option to the drive. If an ov fault occurs after you connect a dynamic braking option and A1-02 = 0 or 2 [Control Method Selection = V/f or CLV] and L3-04 = 0, set L3-04 = 3.

**1 : General Purpose**

The drive decelerates as specified by the deceleration time. When the DC bus voltage is more than the Stall Prevention level, the drive stops deceleration until the DC bus voltage is less than the Stall Prevention Level. The drive then starts to decelerate at the set deceleration time. Frequent use of Stall Prevention will help prevent ov faults when the deceleration time is shorter than the drive can usually accept.

**Note:**

The Decel Stall Prevention function will increase the deceleration time to stop and the deceleration time will be longer than the setting. This function is not applicable for conveyor applications because the precision of the stop position is very important. As an alternative, use a dynamic braking option in these applications.

The input voltage setting of E1-01 [Input AC Supply Voltage] sets the DC bus voltage level for Stall Prevention.

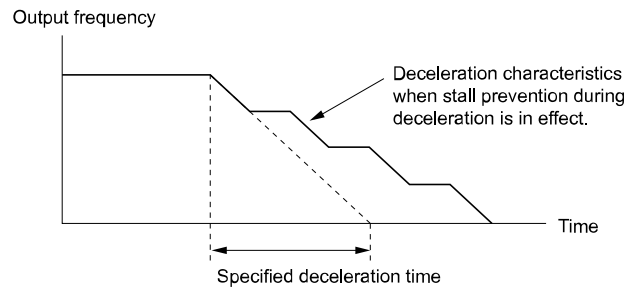
Table 2.68 Stall Prevention Level during Deceleration

| Drive Input Voltage | Stall Prevention Level during Deceleration |
|---------------------|--|
| 200 V class         | 377 V                                      |
| 400 V class         | 754 V                                      |

Parameter Details

## 2.9 L: Protection Functions

Figure 2.134 shows the Stall Prevention during deceleration function.



**Figure 2.134 Stall Prevention Operation during Deceleration**

### 2 : Intelligent (Ignore Decel Ramp)

The drive adjusts the deceleration rate to keep the DC bus voltage at the *L3-17 [DC Bus Regulation Level]* level. This makes the shortest possible deceleration time and will not let the motor stall. The drive ignores the selected deceleration time and the possible deceleration time cannot be less than 1/10 of the set deceleration time.

This function uses these parameters to adjust the deceleration rate:

- *L3-20 [DC Bus Voltage Adjustment Gain]*
- *L3-21 [OVSuppression Accel/Decel P Gain]*
- *L3-24 [Motor Accel Time @ Rated Torque]*
- *L3-25 [Load Inertia Ratio]*

**Note:**

The deceleration time is not constant. For applications where the precision of the stop position is very important, use a dynamic braking option and set *L3-04 = 0*. If an *ov* occurs, set *L3-04 = 3*.

### 3 : General Purpose w/ DB resistor

A braking resistor is necessary for this setting. The braking resistor and the drive work together for the Stall Prevention during deceleration function.

### 4 : Overexcitation/High Flux

Enables Overexcitation/High Flux and enables a shorter deceleration time than when *L3-04 = 0*.

**Note:**

- If the overexcitation time is long and you decelerate frequently, the drive can detect *oLI [Motor Overload]* faults. If the drive detects *oLI*, decrease the deceleration time or install a braking resistor to the drive.
- The deceleration time during Overexcitation Deceleration changes when the motor characteristics and machine inertia change. Adjust the *n3-13 [OverexcitationBraking (OEB) Gain]* and *n3-23 [Overexcitation Braking Operation]* levels. Refer to “n3: HighSlip/OverexciteBraking” for more information about the overexcitation function.

### 5 : Overexcitation/High Flux 2

Enables Overexcitation/High Flux 2. This function decreases the possible deceleration time more than Overexcitation/High Flux.

The drive decreases motor speed and tries to keep the DC bus voltage at the *L3-17* level.

If the drive detects *oLI*, decrease the values set in *n3-13* and *n3-21*. If the drive detects *ov*, increase the values set in *C1-02*, *C1-04*, *C1-06*, and *C1-08 [Deceleration Times]*.

**Note:**

- During Overexcitation/High Flux 2, the drive disables Hunting Prevention in V/f Control and also disables Speed Control that uses torque limit in OLV Control.
- Refer to “n3: HighSlip/OverexciteBraking” for more information about the overexcitation function.

## ■ L3-05: Stall Prevention during RUN

| No. (Hex.)   | Name                        | Description   | Default (Range)                |
|--------------|-----------------------------|---|--------------------------------|
| L3-05 (0493) | Stall Prevention during RUN | <input type="checkbox"/> V/f <input type="checkbox"/> CL-V/f <input type="checkbox"/> OLV <input type="checkbox"/> CLV <input type="checkbox"/> AOLV <input checked="" type="checkbox"/> OLV/PM <input type="checkbox"/> AOLV/PM <input type="checkbox"/> CLV/PM <input type="checkbox"/> EZOLV | 2<br>(0 - Determined by A1-02) |

Stall Prevention function during run prevents the motor from stalling by automatically reducing the speed when an *oLI* [Motor Overload] occurs while the motor is running at constant speed.

**Note:**

1. An output frequency less than 6 Hz will disable Stall Prevention during Run regardless of *L3-05* and *L3-06* [Stall Prevent Level during Run] settings.
2. The setting range changes when the *A1-02* [Control Method] value changes:
  - *A1-02* = 0, 1, 5 [V/f, CL-V/f, OLV/PM]: 0 to 2
  - *A1-02* = 8 [EZOLV]: 0, 3

**0 : No**

The drive runs at the set frequency reference. A heavy load can cause the drive to detect *oC* [Overcurrent] or *oLI*, possibly resulting in motor stall.

**1 : Deceleration Time 1 (C1-02)**

The drive will decelerate for the time set in *C1-02* [Deceleration Time 1] when the current is more than the Stall Prevention level set in *L3-06*. When the current level is less than the “*L3-06* setting value - 2%” for 100 ms, the drive accelerates again for the acceleration time applicable at that time until it reaches the set frequency.

**2 : Deceleration Time 2 (C1-04)**

This setting functions the same as *Setting 1* [Deceleration Time 1 (*C1-02*)]. When the Stall Prevention function is enabled, the drive decelerates with the value set in *C1-04* [Deceleration Time 2].

**3 : Intelligent (Ignore Decel Ramp)**

Available when *A1-02* = 8 [EZOLV]. The drive operates with the largest possible output and prevents motor stalling.

**■ L3-06: Stall Prevent Level during Run**

| No. (Hex.)   | Name                           | Description   | Default (Range)                          |
|--------------|--------------------------------|---|--|
| L3-06 (0494) | Stall Prevent Level during Run | <br>Sets the output current level to enable the Stall Prevention function during operation as a percentage of the drive rated output current. | Determined by C6-01 and L8-38 (5 - 150%) |

**Note:**

- This parameter is applicable if *L3-05* = 1, 2 [Stall Prevention during RUN = Deceleration Time 1 (*C1-02*), Deceleration Time 2 (*C1-04*)].
- When *L3-23* = 1 [Stall P Reduction at Constant HP = Automatic Reduction @ CHP Region], the drive will automatically decrease the level in the constant output range.
- The upper limit of the setting range changes when the setting for *C6-01* [Normal / Heavy Duty Selection] changes.
  - 150% when *C6-01* = 0 [Heavy Duty Rating 1 (HD1) for Constant Torque Applications].
  - 110% when *C6-01* = 1 [Normal Duty Rating 1 (ND1) for Variable Torque Applications].

**Use an Analog Input to Change the Stall Prevent Level during Run**

When *H3-xx* = 8 [MFAI Function Select = Stall Prevent Level During Run], you can change the stall prevention level during run through the input gain and bias settings for terminals A1, A2, and A3.

If you set the input level for *terminals A1, A2, and A3* [*H3-xx* = 8] and *L3-06*, the drive will use the smaller value for Stall Prevent Level during Run.

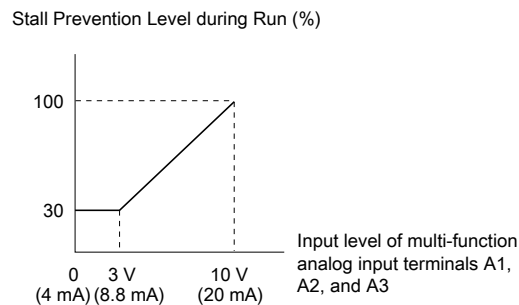


Figure 2.135 Stall Prevention Level during Run with Analog Input

## 2.9 L: Protection Functions

### ■ L3-11: Overvoltage Suppression Select

| No. (Hex.)   | Name                           | Description  | Default (Range) |
|--------------|--------------------------------|--|-----------------|
| L3-11 (04C7) | Overvoltage Suppression Select | <b>V/f</b> <b>CL-V/f</b> <b>OLV</b> <b>CLV</b> <b>AOLV</b> <b>OLV/PM</b> <b>AOLV/PM</b> <b>CLV/PM</b> <b>EZOLV</b><br>Sets the overvoltage suppression function. | 0<br>(0, 1)     |

#### 0 : Disabled

The drive does not adjust the regenerative torque limit or the output frequency. If you apply a regenerative load, the drive can detect an *ov* [Overvoltage] fault. Use this setting with a dynamic braking option.

#### 1 : Enabled

When a regenerative load increases the DC bus voltage, the drive decreases the regenerative torque limit and increases the output frequency to prevent *ov*

### ■ L3-17: DC Bus Regulation Level

| No. (Hex.)   | Name                    | Description   | Default (Range)  |
|--------------|-------------------------|---|--|
| L3-17 (0462) | DC Bus Regulation Level | <b>V/f</b> <b>CL-V/f</b> <b>OLV</b> <b>CLV</b> <b>AOLV</b> <b>OLV/PM</b> <b>AOLV/PM</b> <b>CLV/PM</b> <b>EZOLV</b><br>Sets the target value for the DC bus voltage when the overvoltage suppression function and the Decel Stall Prevention function (Intelligent Stall Prevention) are active. | 200 V Class: 375 V, 400 V: 750 V<br>(200 V Class: 150 to 400 V, 400 V Class: 300 to 800 V) |

#### Note:

This value is initialized when *E1-01* [Input AC Supply Voltage] is changed.

Sets this parameter for any of the following circumstances.

- *L3-11* = 1 [OV Suppression Function Select = Enabled].
- *L3-04* = 2 [Decel Stall Prevention Selection = Automatic Decel Reduction].

### ■ L3-20: DC Bus Voltage Adjustment Gain

| No. (Hex.)             | Name                           | Description  | Default (Range)                      |
|------------------------|--------------------------------|--|--------------------------------------|
| L3-20 (0465)<br>Expert | DC Bus Voltage Adjustment Gain | <b>V/f</b> <b>CL-V/f</b> <b>OLV</b> <b>CLV</b> <b>AOLV</b> <b>OLV/PM</b> <b>AOLV/PM</b> <b>CLV/PM</b> <b>EZOLV</b><br>Sets the proportional gain used to control the DC bus voltage. | Determined by A1-02<br>(0.00 - 5.00) |

Set one of these parameters to enable L3-20:

- *L2-29* = 1 [KEB Method Selection = Single Drive KEB Ride-Thru 2]
- *L3-04* = 2 [Decel Stall Prevention Selection = Automatic Decel Reduction]
- *L3-11* = 1 [OV Suppression Function Select = Enabled]
- *H1-xx* = 7A or 7B [MFDI Function Select = KEB Ride-Thru 2 (N.O./N.C.)]

#### Note:

- If stall prevention during deceleration function causes *ov* [Overvoltage] and *Uv1* [DC Bus Undervoltage] faults when you start deceleration and *L2-29* = 1, *H1-xx* = 7A or 7B, or *L3-04* = 2, gradually increase this parameter in 0.1-unit increments. If the setting value is too high, it can cause large speed or current ripples.
- If sudden increases in the regenerative load cause *ov* faults and *L3-11* = 1, gradually increase this parameter in 0.1-unit increments. If the setting value is too high, it can cause large speed or current ripples.

### ■ L3-21: OVSUPPRESSION ACCEL/DECCEL P GAIN

| No. (Hex.)             | Name                              | Description  | Default (Range)                       |
|------------------------|-----------------------------------|--|---------------------------------------|
| L3-21 (0466)<br>Expert | OVSUPPRESSION ACCEL/DECCEL P Gain | <b>V/f</b> <b>CL-V/f</b> <b>OLV</b> <b>CLV</b> <b>AOLV</b> <b>OLV/PM</b> <b>AOLV/PM</b> <b>CLV/PM</b> <b>EZOLV</b><br>Sets the proportional gain to calculate acceleration and deceleration rates. | Determined by A1-02<br>(0.10 - 10.00) |

Set one of these parameters to enable L3-21:

- *L2-29* = 1 [KEB Method Selection = Single Drive KEB Ride-Thru 2]
- *L3-04* = 2 [Decel Stall Prevention Selection = Automatic Decel Reduction]

- $L3-11 = 1$  [OV Suppression Function Select = Enabled]
- $H1-xx = 7A$  or  $7B$  [MFDI Function Select = KEB Ride-Thru 2 (N.O./N.C.)]

**Note:**

- If stall prevention during deceleration function causes large speed or current ripples and  $L2-29 = 1$ ,  $H1-xx = 7A$  or  $7B$ , or  $L3-04 = 2$ , gradually decrease this parameter in 0.05-unit increments. If the drive detects *ov* [Overvoltage] or *oC* [Overcurrent], decrease this parameter. If you decrease the gain too much, it can cause a delay in control in the DC bus voltage or the deceleration time could be longer than the best deceleration time.
- If sudden increases in the regenerative load cause *ov* faults and  $L3-11 = 1$ , gradually increase this parameter in 0.1-unit increments. If there are large speed ripples, gradually decrease this parameter in 0.05-unit increments.

■ **L3-22: PM Stall Prevention Decel Time**

| No. (Hex.)   | Name                           | Description  | Default (Range)           |
|--------------|--------------------------------|--|---------------------------|
| L3-22 (04F9) | PM Stall Prevention Decel Time | <div style="display: flex; justify-content: space-between; font-size: 0.8em;"> <span>V/f</span> <span>CL-V/f</span> <span>OLV</span> <span>CLV</span> <span>AOLV</span> <span style="background-color: #ccc;">OLV/PM</span> <span>AOLV/PM</span> <span>CLV/PM</span> <span>EZOLV</span> </div> <p>Sets the momentary deceleration time that the drive will use when it tries to accelerate a PM motor and detected motor stalls. This function is applicable when <math>L3-01 = 1</math> [Stall Prevent Select duringAccel = General Purpose].</p> | 0.0 s<br>(0.0 - 6000.0 s) |

Set this parameter to 0.0 s to disable this function. The drive will decelerates in the deceleration time applicable at the time when a motor stall occurs.

■ **L3-23: Stall P Reduction at Constant HP**

| No. (Hex.)   | Name                             | Description   | Default (Range) |
|--------------|----------------------------------|---|-----------------|
| L3-23 (04FD) | Stall P Reduction at Constant HP | <div style="display: flex; justify-content: space-between; font-size: 0.8em;"> <span>V/f</span> <span style="background-color: #ccc;">CL-V/f</span> <span>OLV</span> <span>CLV</span> <span>AOLV</span> <span>OLV/PM</span> <span>AOLV/PM</span> <span>CLV/PM</span> <span>EZOLV</span> </div> <p>Sets the function to automatically decrease the Stall Prevention Level during Run for constant output ranges.</p> | 0<br>(0, 1)     |

**0 : Use L3-06 for Entire Speed Range**

The drive uses the level set in  $L3-06$  [Stall Prevent Level during Run] through the full speed range.

**1 : Automatic Reduction @ CHP Region**

The drive decreases the Stall Prevention level during run in the constant power range. The lower limit is 40% of the  $L3-06$  value.

■ **L3-24: Motor Accel Time for Inertia Cal**

| No. (Hex.)             | Name                             | Description  | Default (Range)  |
|------------------------|----------------------------------|--|--|
| L3-24 (046E)<br>Expert | Motor Accel Time for Inertia Cal | <div style="display: flex; justify-content: space-between; font-size: 0.8em;"> <span>V/f</span> <span>CL-V/f</span> <span>OLV</span> <span>CLV</span> <span>AOLV</span> <span style="background-color: #ccc;">OLV/PM</span> <span>AOLV/PM</span> <span>CLV/PM</span> <span>EZOLV</span> </div> <p>Sets the motor acceleration time to reach the maximum frequency at the motor rated torque for stopped single-drive motors.</p> | Determined by o2-04, C6-01, E2-11, and E5-01<br>(0.001 - 10.000 s) |

Set one of these parameters to enable L3-20:

- $L2-29 = 1$  [KEB Method Selection = Single Drive KEB Ride-Thru 2]
- $L3-04 = 2$  [Decel Stall Prevention Selection = Automatic Decel Reduction]
- $L3-11 = 1$  [OV Suppression Function Select = Enabled]
- $H1-xx = 7A$  or  $7B$  [MFDI Function Select = KEB Ride-Thru 2 (N.O./N.C.)]

**Note:**

When Auto-Tuning changes the value of  $E2-11$  [Motor Rated Power (kW)], the drive will automatically set  $L3-24$  to the value for a Yaskawa standard motor (4 poles). When you use a PM motor, the drive uses the value in  $E5-01$  [PM Motor Code Selection] to change  $L3-24$ .

**Automatically Adjust Parameters**

If  $A1-02 = 3, 7$  [Control Method Selection = CLV, CLV/PM], do Inertia Tuning. Parameters are automatically adjusted.

**Manually Adjust Parameters**

Use this formula to find the motor acceleration time:

$$L3-24 = \frac{2\pi \cdot J_{\text{Motor}} \cdot n_{\text{rated}}}{60 \cdot T_{\text{rated}}}$$

## 2.9 L: Protection Functions

- $J_{\text{Motor}}$  = Moment of inertia of motor (kg m<sup>2</sup>)
- $n_{\text{rated}}$  = Motor rated speed (min<sup>-1</sup>, r/min)
- $T_{\text{rated}}$  = Motor rated torque (N·m)

The rated torque is calculated using the following expression.

$$T_{\text{rated}} = \frac{60 \cdot P_{\text{Motor}} \cdot 10^3}{2\pi \cdot n_{\text{rated}}}$$

$P_{\text{Motor}}$  = Motor Rated Power (kW)

### ■ L3-25: Load Inertia Ratio

| No. (Hex.)                | Name               | Description   | Default (Range)       |
|---------------------------|--------------------|---|-----------------------|
| L3-25<br>(046F)<br>Expert | Load Inertia Ratio | <div style="display: flex; justify-content: space-between; font-size: 0.8em;"> <span>V/f</span> <span>CL-V/f</span> <span>OLV</span> <span>CLV</span> <span>AOLV</span> <span>OLV/PM</span> <span>AOLV/PM</span> <span>CLV/PM</span> <span>EZOLV</span> </div> <p>Sets the ratio between motor inertia and machine inertia.</p> | 1.0<br>(0.1 - 1000.0) |

Set one of these parameters to enable L3-20:

- $L2-29 = 1$  [*KEB Method Selection = Single Drive KEB Ride-Thru 2*]
- $L3-04 = 2$  [*Decel Stall Prevention Selection = Automatic Decel Reduction*]
- $L3-11 = 1$  [*OV Suppression Function Select = Enabled*]
- $H1-xx = 7A$  or  $7B$  [*MFDI Function Select = KEB Ride-Thru 2 (N.O./N.C.)*]

**Note:**

- If you set this value incorrectly when  $L2-29 = 1$ ,  $H1-xx = 7A$  or  $7B$ , or  $L3-11 = 1$ , it can cause large current ripples and *ov* [Overvoltage], *Uv1* [DC Bus Undervoltage], or *oC* [Overcurrent] faults.
- KEB Tuning will automatically set this value.

#### Automatically Adjust Parameters

If  $A1-02 = 3, 7$  [*Control Method Selection = CLV, CLV/PM*], do Inertia Tuning. Parameters are automatically adjusted.

#### Manually Adjust Parameters

Use this formula to find the load inertia ratio:

$$\text{Load inertia ratio} = \frac{\text{Machine inertia (Motor shaft conversion value)}}{\text{Motor inertia}}$$

### ■ L3-26: Additional DC Bus Capacitors

| No. (Hex.)                | Name                         | Description  | Default (Range)         |
|---------------------------|------------------------------|--|-------------------------|
| L3-26<br>(0455)<br>Expert | Additional DC Bus Capacitors | <div style="display: flex; justify-content: space-between; font-size: 0.8em;"> <span>V/f</span> <span>CL-V/f</span> <span>OLV</span> <span>CLV</span> <span>AOLV</span> <span>OLV/PM</span> <span>AOLV/PM</span> <span>CLV/PM</span> <span>EZOLV</span> </div> <p>Sets the capacity for external main circuit capacitors. Usually it is not necessary to change this setting. Sets this parameter when you use the KEB Ride-Thru function.</p> | 0 μF<br>(0 to 65000 μF) |

### ■ L3-27: Stall Prevention Detection Time

| No. (Hex.)      | Name                            | Description   | Default (Range)        |
|-----------------|---------------------------------|---|------------------------|
| L3-27<br>(0456) | Stall Prevention Detection Time | <div style="display: flex; justify-content: space-between; font-size: 0.8em;"> <span>V/f</span> <span>CL-V/f</span> <span>OLV</span> <span>CLV</span> <span>AOLV</span> <span>OLV/PM</span> <span>AOLV/PM</span> <span>CLV/PM</span> <span>EZOLV</span> </div> <p>Sets a delay time between reaching the Stall Prevention level and starting the Stall Prevention function.</p> | 50 ms<br>(0 - 5000 ms) |

### ■ L3-34: Torque Limit Delay Time

| No. (Hex.)                | Name                    | Description  | Default (Range)                          |
|---------------------------|-------------------------|--|--|
| L3-34<br>(016F)<br>Expert | Torque Limit Delay Time | <div style="display: flex; justify-content: space-between; font-size: 0.8em;"> <span>V/f</span> <span>CL-V/f</span> <span>OLV</span> <span>CLV</span> <span>AOLV</span> <span>OLV/PM</span> <span>AOLV/PM</span> <span>CLV/PM</span> <span>EZOLV</span> </div> <p>Sets the filter time constant that returns the torque limit to its initial value when KEB operation operates in Single Drive KEB Ride-Thru mode.</p> | Determined by A1-02<br>(0.000 - 1.000 s) |



When vibration occurs during operation of Single Drive KEB Ride-Thru 2, increase this parameter in 0.010-unit increments.

**Note:**

The Single Drive KEB Ride-Thru 2 mode operates when  $L2-29 = 1$  [*KEB Method Selection = Single Drive KEB Ride-Thru 2*] and  $H1-xx = 7A$  or  $7B$  [*Terminal Sx Function Selection = KEB Ride-Thru 2 (N.C./N.O.)*].

### ■ L3-35: Speed Agree Width for Auto Decel

| No. (Hex.)                | Name                             | Description  | Default (Range)             |
|---------------------------|----------------------------------|--|-----------------------------|
| L3-35<br>(0747)<br>Expert | Speed Agree Width for Auto Decel | <b>V/f</b> <b>CL-V/f</b> <b>OLV</b> <b>CLV</b> <b>AOLV</b> <b>OLV/PM</b> <b>AOLV/PM</b> <b>CLV/PM</b> <b>EZOLV</b><br>Sets the width for speed agreement when $L3-04 = 2$ [ <i>Decel Stall Prevention Selection = Automatic Decel Reduction</i> ]. Usually it is not necessary to change this setting. | 0.00 Hz<br>(0.00 - 1.00 Hz) |

Set this parameter when hunting occurs while you use a frequency reference through an analog input.

### ■ L3-36: Current Suppression Gain@Accel

| No. (Hex.)      | Name                           | Description  | Default (Range)                      |
|-----------------|--------------------------------|--|--------------------------------------|
| L3-36<br>(11D0) | Current Suppression Gain@Accel | <b>V/f</b> <b>CL-V/f</b> <b>OLV</b> <b>CLV</b> <b>AOLV</b> <b>OLV/PM</b> <b>AOLV/PM</b> <b>CLV/PM</b> <b>EZOLV</b><br>Sets the gain to suppress current and motor speed hunting during operation when $L3-01 = 3$ [ <i>Stall Prevention during Accel = Current Limit Method</i> ]. Usually it is not necessary to change this setting. | Determined by A1-02<br>(0.0 - 100.0) |

If there is vibration in the output current during acceleration, increase the setting value.

**Note:**

Set  $L3-01 = 3$  [*Stall Prevention during Accel = Current Limit Method*] to enable this function.

### ■ L3-37: Current Limit P Gain @ Accel

| No. (Hex.)                | Name                         | Description   | Default (Range)      |
|---------------------------|------------------------------|---|----------------------|
| L3-37<br>(11D1)<br>Expert | Current Limit P Gain @ Accel | <b>V/f</b> <b>CL-V/f</b> <b>OLV</b> <b>CLV</b> <b>AOLV</b> <b>OLV/PM</b> <b>AOLV/PM</b> <b>CLV/PM</b> <b>EZOLV</b><br>Suppresses current hunting that occurs during acceleration. Usually it is not necessary to change this setting. | 5 ms<br>(0 - 100 ms) |

**Note:**

Set  $L3-01 = 3$  [*Stall Prevention during Accel = Current Limit Method*] to enable this function.

### ■ L3-38: Current Limit I Time @ Accel

| No. (Hex.)                | Name                         | Description  | Default (Range)       |
|---------------------------|------------------------------|--|-----------------------|
| L3-38<br>(11D2)<br>Expert | Current Limit I Time @ Accel | <b>V/f</b> <b>CL-V/f</b> <b>OLV</b> <b>CLV</b> <b>AOLV</b> <b>OLV/PM</b> <b>AOLV/PM</b> <b>CLV/PM</b> <b>EZOLV</b><br>Suppresses current hunting and overshooting that occurs when the drive stalls during acceleration. Usually it is not necessary to change this setting. | 10.0<br>(0.0 - 100.0) |

**Note:**

Set  $L3-01 = 3$  [*Stall Prevention during Accel = Current Limit Method*] to enable this function.

### ■ L3-39: Current Limit Filter Time @Accel

| No. (Hex.)      | Name                             | Description  | Default (Range)               |
|-----------------|----------------------------------|--|-------------------------------|
| L3-39<br>(11D3) | Current Limit Filter Time @Accel | <b>V/f</b> <b>CL-V/f</b> <b>OLV</b> <b>CLV</b> <b>AOLV</b> <b>OLV/PM</b> <b>AOLV/PM</b> <b>CLV/PM</b> <b>EZOLV</b><br>Sets the time constant to adjust the acceleration rate when $L3-01 = 3$ [ <i>Stall Prevention during Accel = Current Limit Method</i> ]. Usually it is not necessary to change this setting. | 100.0 ms<br>(1.0 - 1000.0 ms) |

**Note:**

Set  $L3-01 = 3$  [*Stall Prevention during Accel = Current Limit Method*] to enable this function.

## 2.9 L: Protection Functions

### ■ L3-40: Current Limit S-Curve @ Acc/Dec

| No. (Hex.)      | Name                            | Description  | Default (Range) |
|-----------------|---------------------------------|--|-----------------|
| L3-40<br>(11D4) | Current Limit S-Curve @ Acc/Dec | <input type="checkbox"/> V/f <input type="checkbox"/> CL-V/f <input type="checkbox"/> OLV <input type="checkbox"/> CLV <input type="checkbox"/> AOLV <input type="checkbox"/> OLV/PM <input type="checkbox"/> AOLV/PM <input type="checkbox"/> CLV/PM <input type="checkbox"/> EZOLV<br>Sets the function to enable and disable the best S-curve characteristic used for current-limited acceleration. | 0<br>(0, 1)     |

Makes the best motor acceleration rate for start up. If you set this parameter to 1, it will make acceleration smoother, but it can also increase the acceleration time to be longer than the set time. If the drive detects *oC* [Overcurrent] faults immediately after acceleration starts, set this parameter.

**0 : No**

**1 : Yes**

**Note:**

Set L3-01 = 3 [Stall Prevention during Accel = Current Limit Method] to enable this function.

### ◆ L4: Speed Detection

L4 parameters set the output of signals to the MFDO terminals, for example frequency agree and speed detection. The drive detects motor speed in CLV or CLV/PM control methods.

#### ■ L4-01: Speed Agree Detection Level

| No. (Hex.)      | Name                        | Description  | Default (Range)                              |
|-----------------|-----------------------------|--|--|
| L4-01<br>(0499) | Speed Agree Detection Level | <input type="checkbox"/> V/f <input type="checkbox"/> CL-V/f <input type="checkbox"/> OLV <input type="checkbox"/> CLV <input type="checkbox"/> AOLV <input type="checkbox"/> OLV/PM <input type="checkbox"/> AOLV/PM <input type="checkbox"/> CLV/PM <input type="checkbox"/> EZOLV<br>Sets the level to detect speed agree or motor speed. | Determined by A1-02<br>(Determined by A1-02) |

Sets the level to detect speed agree or motor speed when H2-01 to H2-03 = 2, 3, 4, 5 [MFDO Function Select = Speed Agree 1, User-set Speed Agree 1, Frequency Detection 1, Frequency Detection 2].

#### ■ L4-02: Speed Agree Detection Width

| No. (Hex.)      | Name                        | Description  | Default (Range)                              |
|-----------------|-----------------------------|--|--|
| L4-02<br>(049A) | Speed Agree Detection Width | <input type="checkbox"/> V/f <input type="checkbox"/> CL-V/f <input type="checkbox"/> OLV <input type="checkbox"/> CLV <input type="checkbox"/> AOLV <input type="checkbox"/> OLV/PM <input type="checkbox"/> AOLV/PM <input type="checkbox"/> CLV/PM <input type="checkbox"/> EZOLV<br>Sets the width to detect speed agree or motor speed. | Determined by A1-02<br>(Determined by A1-02) |

Sets the width to detect speed agree or motor speed when H2-01 to H2-03 = 2, 3, 4, 5 [MFDO Function Select = Speed Agree 1, User-set Speed Agree 1, Frequency Detection 1, Frequency Detection 2].

#### ■ L4-03: Speed Agree Detection Level (+/-)

| No. (Hex.)      | Name                              | Description  | Default (Range)                              |
|-----------------|-----------------------------------|--|--|
| L4-03<br>(049B) | Speed Agree Detection Level (+/-) | <input type="checkbox"/> V/f <input type="checkbox"/> CL-V/f <input type="checkbox"/> OLV <input type="checkbox"/> CLV <input type="checkbox"/> AOLV <input type="checkbox"/> OLV/PM <input type="checkbox"/> AOLV/PM <input type="checkbox"/> CLV/PM <input type="checkbox"/> EZOLV<br>Sets the level to detect speed agree or motor speed. | Determined by A1-02<br>(Determined by A1-02) |

Sets the speed agree detection level or motor speed detection level when H2-01 to H2-03 = 13, 14, 15, 16 [MFDO Function Selection = Speed Agree 2, User-set Speed Agree 2, Frequency Detection 3, Frequency Detection 4].

#### ■ L4-04: Speed Agree Detection Width (+/-)

| No. (Hex.)      | Name                              | Description  | Default (Range)                              |
|-----------------|-----------------------------------|--|--|
| L4-04<br>(049C) | Speed Agree Detection Width (+/-) | <input type="checkbox"/> V/f <input type="checkbox"/> CL-V/f <input type="checkbox"/> OLV <input type="checkbox"/> CLV <input type="checkbox"/> AOLV <input type="checkbox"/> OLV/PM <input type="checkbox"/> AOLV/PM <input type="checkbox"/> CLV/PM <input type="checkbox"/> EZOLV<br>Sets the width to detect speed agree or motor speed. | Determined by A1-02<br>(Determined by A1-02) |

Sets the width to detect speed agree or motor speed when H2-01 to H2-03 = 13, 14, 15, 16 [MFDO Function Selection = Speed Agree 2, User-set Speed Agree 2, Frequency Detection 3, Frequency Detection 4].

### ■ L4-05: Fref Loss Detection Selection

| No. (Hex.)   | Name                          | Description  | Default (Range) |
|--------------|-------------------------------|--|-----------------|
| L4-05 (049D) | Fref Loss Detection Selection | <b>V/f</b> <b>CL-V/f</b> <b>OLV</b> <b>CLV</b> <b>AOLV</b> <b>OLV/PM</b> <b>AOLV/PM</b> <b>CLV/PM</b> <b>EZOLV</b><br>Sets the operation when the drive detects a loss of frequency reference. | 0<br>(0, 1)     |

Enables the detection of a loss of an analog frequency reference when the frequency reference is input from the MFAI terminals (A1, A2, and A3). Set  $H2-01$  to  $H2-03 = C$  [ $MFDO$  Function Select = Frequency Reference Loss] to enable this function.

If the frequency reference is less than 10% in 400 ms, the drive detects frequency reference loss.

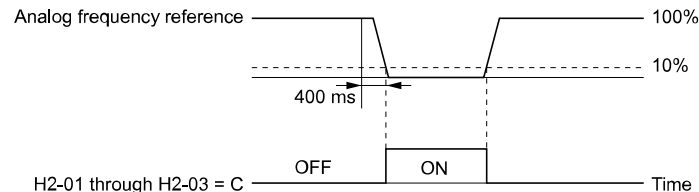


Figure 2.136 Detection of Frequency Reference Loss

#### 0 : Stop

The drive follows the frequency reference and stops the motor.

#### 1 : Run at (L4-06 x Last Reference)

The drive continues to operate at the frequency reference value set in  $L4-06$  [ $FreqReference$  at Reference Loss]. When you return the external frequency reference value, the drive continues to operate with the frequency reference.

### ■ L4-06: Frequency Reference @Loss of Ref

| No. (Hex.)   | Name                             | Description  | Default (Range)         |
|--------------|----------------------------------|--|-------------------------|
| L4-06 (04C2) | Frequency Reference @Loss of Ref | <b>V/f</b> <b>CL-V/f</b> <b>OLV</b> <b>CLV</b> <b>AOLV</b> <b>OLV/PM</b> <b>AOLV/PM</b> <b>CLV/PM</b> <b>EZOLV</b><br>Sets the frequency reference as a percentage to continue drive operation after it detects a frequency reference loss. The value is a percentage of the frequency reference before the drive detected the loss. | 80.0%<br>(0.0 - 100.0%) |

Set  $L4-05 = 1$  [ $FreqReference$  Loss Detect Select = Run@L4-06PrevRef] to enable this parameter.

### ■ L4-07: Speed Agree Detection Selection

| No. (Hex.)   | Name                            | Description  | Default (Range) |
|--------------|---------------------------------|--|-----------------|
| L4-07 (0470) | Speed Agree Detection Selection | <b>V/f</b> <b>CL-V/f</b> <b>OLV</b> <b>CLV</b> <b>AOLV</b> <b>OLV/PM</b> <b>AOLV/PM</b> <b>CLV/PM</b> <b>EZOLV</b><br>Sets the condition that activates speed detection. | 0<br>(0, 1)     |

#### 0 : No Detection during Baseblock

Detects the frequency while the drive is operating. When the drive turns off its output, it will not detect frequency.

#### 1 : Detection Always Enabled

### ◆ L5: Auto Restart

The Auto Restart function tries to keep machines operating when the drive detects a transient fault.

The drive can do a self-diagnostic check and continue the operation after a fault has occurred. If the cause of the fault goes away, the drive does speed search and restarts. It will not stop and the drive will not record a fault history. Use  $L5-02$  [ $Fault$  Contact at Restart Select] to select the operation of fault relay signals during Auto Restart operation.

Sets if the drive will do Auto Restart and the number of times the drive will try to do Auto Restart in a set time. If the number of Auto Restart tries is more than the set value during the set time, drive output shuts off and operation stops. If this happens, remove the cause of the fault and manually restart the drive.

The drive can do Auto Restart when these faults occur:

## 2.9 L: Protection Functions

**Note:**

You can disable Auto Restart for faults if you must not restart the machine after the fault.

**Table 2.69 List of Faults during which Auto Restart is Available**

| Faults | Name                   | Parameters to Disable Auto Restart | Faults | Name                             | Parameters to Disable Auto Restart |
|--------|------------------------|------------------------------------|--------|----------------------------------|------------------------------------|
| GF     | Ground Fault           | L5-08                              | ov     | Overvoltage                      | L5-08                              |
| LF     | Output Phase Loss      | -                                  | PF     | Input Phase Loss                 | -                                  |
| oC     | Overcurrent            | -                                  | rH     | Braking Resistor Overheat        | -                                  |
| oH1    | Heatsink Overheat      | L5-08                              | rr     | Dynamic Braking Transistor Fault | -                                  |
| oL1    | Motor Overload         | L5-07                              | STPo   | Motor Step-Out Detected          | -                                  |
| oL2    | Drive Overload         | L5-07                              | Uv1    | DC Bus Undervoltage *1           | L5-08                              |
| oL3    | Overtorque Detection 1 | L5-07                              |        |                                  |                                    |
| oL4    | Overtorque Detection 2 | L5-07                              |        |                                  |                                    |

\*1 If L2-01 = 1, 2, 3, 4 [Power Loss Ride Through Select = Enabled for L2-02 Time, Enabled while CPU Power Active, KEB Operation, Kinetic Energy Backup: CPU Power], Uv1 becomes a fault during which Auto Restart is available.

### ■ L5-01: Number of Auto-Restart Attempts

| No. (Hex.)   | Name                            | Description  | Default (Range)     |
|--------------|---------------------------------|--|---------------------|
| L5-01 (049E) | Number of Auto-Restart Attempts | <span>V/f</span> <span>CL-V/f</span> <span>OLV</span> <span>CLV</span> <span>AOLV</span> <span>OLV/PM</span> <span>AOLV/PM</span> <span>CLV/PM</span> <span>EZOLV</span><br>Sets the number of times that the drive will try to restart. | 0<br>(0 - 10 times) |

The drive resets the number of Auto Restart attempts to 0 in these conditions:

- The drive operates correctly for 10 minutes after a fault restart.
- When you manually clear a fault after the drive triggers protective functions.
- When you re-energize the drive.

### ■ L5-02: Fault Contact at Restart Select

| No. (Hex.)   | Name                            | Description   | Default (Range) |
|--------------|---------------------------------|---|-----------------|
| L5-02 (049F) | Fault Contact at Restart Select | <span>V/f</span> <span>CL-V/f</span> <span>OLV</span> <span>CLV</span> <span>AOLV</span> <span>OLV/PM</span> <span>AOLV/PM</span> <span>CLV/PM</span> <span>EZOLV</span><br>Sets the function that sends signals to the MFDO terminal set for <i>Fault [H2-xx = E]</i> while the drive is automatically restarting. | 0<br>(0, 1)     |

**0 : Active Only when Not Restarting**

**1 : Always Active**

### ■ L5-03: Auto-Restart Duration

| No. (Hex.)   | Name                  | Description   | Default (Range)           |
|--------------|-----------------------|---|---------------------------|
| L5-03 (04A0) | Auto-Restart Duration | <span>V/f</span> <span>CL-V/f</span> <span>OLV</span> <span>CLV</span> <span>AOLV</span> <span>OLV/PM</span> <span>AOLV/PM</span> <span>CLV/PM</span> <span>EZOLV</span><br>Sets the time for which the drive will try to restart. If the drive cannot restart within the time set in L5-03, a fault is detected. This is available when L5-05 = 0 [Auto-Restart Method = Continuous/Immediate Attempts]. | 10.0 s<br>(0.5 - 180.0 s) |

### ■ L5-04: Interval Method Restart Time

| No. (Hex.)   | Name                         | Description  | Default (Range)           |
|--------------|------------------------------|--|---------------------------|
| L5-04 (046C) | Interval Method Restart Time | <span>V/f</span> <span>CL-V/f</span> <span>OLV</span> <span>CLV</span> <span>AOLV</span> <span>OLV/PM</span> <span>AOLV/PM</span> <span>CLV/PM</span> <span>EZOLV</span><br>Sets the time interval between each Auto Restart attempt. This function is enabled when L5-05 = 1 [Auto Restart Operation Selection = Use L5-04 Time]. | 10.0 s<br>(0.5 - 600.0 s) |

■ L5-05: Auto-Restart Method

| No. (Hex.)   | Name                | Description  | Default (Range) |
|--------------|---------------------|--|-----------------|
| L5-05 (0467) | Auto-Restart Method | <div style="display: flex; gap: 5px;"> <span>V/f</span> <span>CL-V/f</span> <span>OLV</span> <span>CLV</span> <span>AOLV</span> <span>OLV/PM</span> <span>AOLV/PM</span> <span>CLV/PM</span> <span>EZOLV</span> </div> Sets the count method for the Auto Restart operation. | 0 (0, 1)        |

0 : Continuous/Immediate Attempts

Counts the number of successful fault resets through Auto Restart.

When this value > L5-01, the drive will send a fault signal and fault code to the keypad and the motor will coast to stop.

1 : Interval/Attempt after L5-04 sec

Counts the number of fault resets through Auto Restart regardless of whether or not the resets were successful. The drive repeats the Auto Restart process in the intervals set in L5-04 [Interval Method Restart Time].

When this value > L5-01, the drive will send a fault signal and fault code to the keypad and the motor will coast to stop.

■ L5-07: Fault Reset Enable Select Grp1

| No. (Hex.)   | Name                           | Description   | Default (Range)    |
|--------------|--------------------------------|---|--------------------|
| L5-07 (0B2A) | Fault Reset Enable Select Grp1 | <div style="display: flex; gap: 5px;"> <span>V/f</span> <span>CL-V/f</span> <span>OLV</span> <span>CLV</span> <span>AOLV</span> <span>OLV/PM</span> <span>AOLV/PM</span> <span>CLV/PM</span> <span>EZOLV</span> </div> Use these 4 digits to set the Auto Restart function for oL1 to oL4. From left to right, the digits set oL1, oL2, oL3, and oL4, in order. | 1111 (0000 - 1111) |

0000 : No

0001 : Enabled (—/—/—/oL4)

0010 : Enabled (—/—/oL3/—)

0011 : Enabled (—/—/oL3/oL4)

0100 : Enabled (—/oL2/—/—)

0101 : Enabled (—/oL2/—/oL4)

0110 : Enabled (—/oL2/oL3/—)

0111 : Enabled (—/oL2/oL3/oL4)

1000 : Enabled (oL1/—/—/—)

1001 : Enabled (oL1/—/—/oL4)

1010 : Enabled (oL1/—/oL3/—)

1011 : Enabled (oL1/—/oL3/oL4)

1100 : Enabled (oL1/oL2/—/—)

1101 : Enabled (oL1/oL2/—/oL4)

1110 : Enabled (oL1/oL2/oL3/—)

1111 : Enabled (oL1/oL2/oL3/oL4)

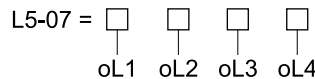


Figure 2.137 Setting Digits and Fault Code

■ L5-08: Fault Reset Enable Select Grp2

| No. (Hex.)   | Name                           | Description   | Default (Range)    |
|--------------|--------------------------------|---|--------------------|
| L5-08 (0B2B) | Fault Reset Enable Select Grp2 | <div style="display: flex; gap: 5px;"> <span>V/f</span> <span>CL-V/f</span> <span>OLV</span> <span>CLV</span> <span>AOLV</span> <span>OLV/PM</span> <span>AOLV/PM</span> <span>CLV/PM</span> <span>EZOLV</span> </div> Use these 4 digits to set the Auto Restart function for Uv1, ov, oHI, and GF. From left to right, the digits set Uv1, ov, oHI, and GF, in order. | 1111 (0000 - 1111) |

0000 : No

Parameter Details

- 0001 : Enabled (—/—/—/GF)
- 0010 : Enabled (—/—/ovH1/—)
- 0011 : Enabled (—/—/ovH1/GF)
- 0100 : Enabled (—/ov/—/—)
- 0101 : Enabled (—/ov/—/GF)
- 0110 : Enabled (—/ov/ovH1/—)
- 0111 : Enabled (—/ov/ovH1/GF)
- 1000 : Enabled (Uv1/—/—/—)
- 1001 : Enabled (Uv1/—/—/GF)
- 1010 : Enabled (Uv1/—/ovH1/—)
- 1011 : Enabled (Uv1/—/ovH1/GF)
- 1100 : Enabled (Uv1/ov/—/—)
- 1101 : Enabled (Uv1/ov/—/GF)
- 1110 : Enabled (Uv1/ov/ovH1/—)
- 1111 : Enabled (Uv1/ov/ovH1/GF)

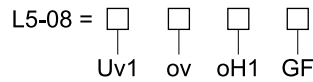


Figure 2.138 Setting Digits and Fault Code

### ◆ L6: Torque Detection

The overtorque/undertorque detection function prevents damage to machinery and loads.

Overtorque is the when there is too much load on the machine. If the motor current or output torque is at the overtorque detection level for the overtorque detection time, the drive will output an alarm and turn off the output.

Undertorque is the when a load suddenly decreases. When the motor current or output torque is at the undertorque detection level for the undertorque detection time, the drive will output an alarm and turn off the output.

You can use the undertorque detection function to detect these conditions, for example:

- Machine belt cuts
- Unusual operation of the electromagnetic contactor on the drive output side
- Clogged output side air filters in fans and blowers
- Damage to blade tips and broken string

**Note:**

If there is *oC* [Overcurrent] or *oL1* [Motor Overload], the drive can stop during overtorque conditions. Use torque detection to identify overload conditions before the drive detects *oC* or *oL1* and stops. Use this function to detect issues that occur in the application.

### ■ Parameter Setting

You can individually set the two overtorque/undertorque detection functions with the drive. Use the information in Table 2.70 to set the parameters.

Table 2.70 Overtorque/Undertorque Detection Parameters

| Configuration Parameter   | Overtorque/Undertorque Detection 1                               | Overtorque/Undertorque Detection 2                               |
|---|--|--|
| MFDO Function Select<br>• Terminals M1-M2<br>• Terminals M3-M4<br>• Terminals M5-M6 | H2-01, H2-02, and H2-03 = B<br>N.O.: Activated when detected     | H2-01, H2-02, and H2-03 = 18<br>N.O.: Activated when detected    |
|   | H2-01, H2-02, and H2-03 = 17<br>N.C.: Disactivated when detected | H2-01, H2-02, and H2-03 = 19<br>N.C.: Disactivated when detected |
| Detection conditions and selection of operation after detection                     | L6-01  | L6-04  |
| Detection Level   | L6-02  | L6-05  |
|   | Analog Input Terminal *I<br>H3-xx = 7                            | -  |

| Configuration Parameter | Overtorque/Undertorque Detection 1 | Overtorque/Undertorque Detection 2 |
|-------------------------|------------------------------------|------------------------------------|
| Detection Time          | L6-03                              | L6-06                              |

\*1 You can also use an analog input terminal to supply the torque detection level. To enable this function, set  $H3-xx = 7$  [MFAI Function Selection = Overtorque/Undertorque DetectLvl]. If both L6-02 and  $H3-xx = 7$  are set, the analog input has priority and the setting of L6-02 is disabled.

You cannot use Overtorque/Undertorque Detection 2 to set the detection level for the analog input terminals.

**Note:**

In V/f Control, the drive uses the current level (100% of the drive rated output current) to detect overtorque/undertorque. In vector control, the drive uses the motor torque (100% of the motor rated torque) to detect overtorque/undertorque. When you enable the mechanical weakening detection function, the overtorque/undertorque detection level for all control modes is the current level (100% of the drive rated output current).

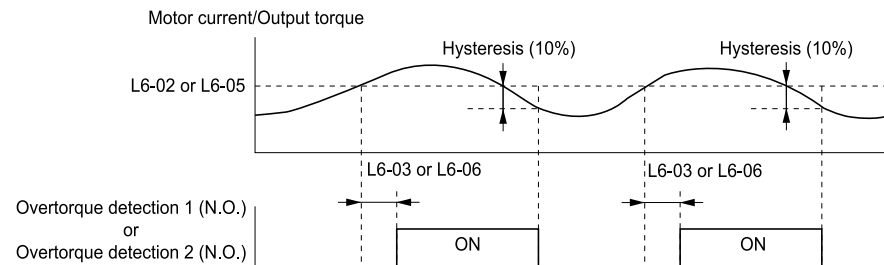
**Time Chart for Detection of Overtorque/Undertorque**

**Overtorque Detection Time Chart**

When you use Overtorque/Undertorque Detection 1, the drive detects overtorque if the motor current or motor torque is at the detection level set in L6-02 [Torque Detection Level 1] for the time set in L6-03 [Torque Detection Time 1]. Parameter L6-01 [Torque Detection Selection 1] sets the operation after detection.

When you use Overtorque/Undertorque Detection 2, set L6-04 [Torque Detection Selection 2], L6-05 [Torque Detection Level 2], and L6-06 [Torque Detection Time 2].

Set the terminal that outputs the alarm in H2-01 to H2-03 [MFDO Function Select].



**Figure 2.139 Overtorque Detection Time Chart**

**Note:**

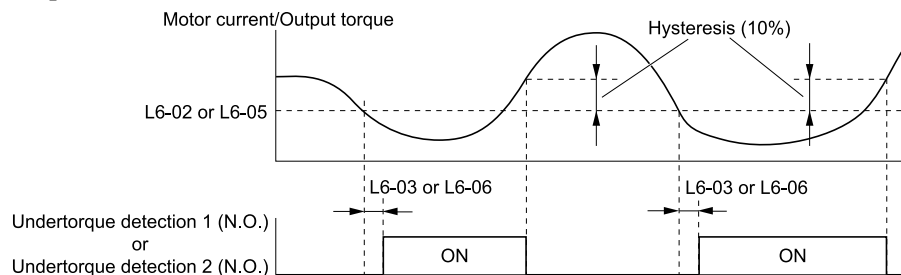
The drive applies a hysteresis of approximately 10% of the drive rated output current or the motor rated torque to the overtorque/undertorque detection function.

**Undertorque Detection Time Chart**

When you use Overtorque/Undertorque Detection 1, the drive detects undertorque if the motor current or motor torque is less than or equal to the detection level set in L6-02 for the time set in L6-03. Parameter L6-01 sets the operation after detection.

When you use Overtorque/Undertorque Detection 2, set the operation in L6-04, L6-05, and L6-06.

Set the terminal that outputs an alarm in H2-01 to H2-03.



**Figure 2.140 Undertorque Detection Time Chart**

**Note:**

The drive applies a hysteresis of approximately 10% of the drive rated output current or the motor rated torque to the overtorque/undertorque detection function.

### ■ Mechanical Weakening Detection

The Mechanical Weakening Detection function detects the mechanical weakening of a machine that can cause overtorque or undertorque because of motor speed and total drive operation time.

The drive activates the function if the drive total operation time is longer than the time set in L6-11 [Mech Fatigue Hold Off Time]. You can use U4-01 [Cumulative Ope Time] to monitor the total operation time.

#### Parameter Settings


The drive detects Mechanical Weakening if overtorque or undertorque occur during the speed range set in L6-08 [Mechanical Fatigue Detect Select] and L6-09 [Mech Fatigue Detect Speed Level] for the length of time set in L6-10 [Mech Fatigue Detect Delay Time]. The drive uses L6-01 to L6-03 [Torque Detection 1 Setting Parameter] to detect oL5 [Mechanical Weakening Detection 1] or UL5 [Mechanical Weakening Detection 2]. Parameter L6-08 sets the operation after detection.

Set the terminal that outputs the fault in H2-01 to H2-03 [MFDO Function Select].

**Table 2.71 Mechanical Weakening Detection Settings Parameters**

| Configuration Parameter   |                    | Mechanical Deterioration Detection |
|---|--------------------|------------------------------------|
| MFDO Function Select<br>• Terminals M1-M2<br>• Terminals M3-M4<br>• Terminals M5-M6 |                    | H2-01, H2-02, and H2-03 = 22       |
| Operation Selection after Detection   |                    | L6-08                              |
| Detection Start Time  |                    | L6-11                              |
| Speed Range   | Detection Criteria | L6-08                              |
|   | Detection Level    | L6-09                              |
|   | Detection Time     | L6-10                              |
| Overtorque  | Detection Criteria | L6-01                              |
|   | Detection Level    | L6-02                              |
|   | Detection Time     | L6-03                              |

### ■ L6-01: Torque Detection Selection 1

| No. (Hex.)   | Name                         | Description  | Default (Range) |
|--------------|------------------------------|--|-----------------|
| L6-01 (04A1) | Torque Detection Selection 1 | <br>Sets the speed range that detects overtorque and undertorque and the operation of drives (operation status) after detection. | 0 (0 - 8)       |

The drive detects overtorque if the motor current or output torque is more than the level set in L6-02 [Torque Detection Level 1] for the length of time set in L6-03 [Torque Detection Time 1]. The drive detects undertorque if the motor current or output torque is less than the level set in L6-02 for the length the time set in L6-03.

#### 0 : Disabled

The drive will not detect overtorque or undertorque.

#### 1 : oL @ Speed Agree - Alarm only

The drive detects overtorque when the output frequency aligns with the frequency reference. Detection does not occur during acceleration/deceleration. The drive outputs an oL3 [Overtorque Detection 1] and operation continues.

#### 2 : oL @ RUN - Alarm only

When the Run command is enabled, the drive constantly detects overtorque. The drive outputs an oL3 and operation continues.

#### 3 : oL @ Speed Agree - Fault

The drive detects overtorque when the output frequency aligns with the frequency reference. Detection does not occur during acceleration/deceleration. The drive outputs an oL3 [Overtorque Detection 1] and operation stops.

#### 4 : oL @ RUN - Fault



When the Run command is enabled, the drive constantly detects overtorque. The drive outputs an *oL3* and operation stops.

#### 5 : UL @ Speed Agree - Alarm only

The drive detects undertorque when the output frequency aligns with the frequency reference. Detection does not occur during acceleration/deceleration. The drive outputs a *UL3* [*Undertorque Detection 1*] and operation continues.

#### 6 : UL @ RUN - Alarm only

When the Run command is enabled, the drive constantly detects undertorque. The drive outputs a *UL3* and operation continues.

#### 7 : UL @ Speed Agree - Fault

The drive detects undertorque when the output frequency aligns with the frequency reference. Detection does not occur during acceleration/deceleration. The drive outputs a *UL3* and operation stops.

#### 8 : UL @ RUN - Fault

When the Run command is enabled, the drive constantly detects undertorque. The drive outputs a *UL3* and operation stops.

### ■ L6-02: Torque Detection Level 1

| No. (Hex.)   | Name                     | Description   | Default (Range)    |
|--------------|--------------------------|---|--------------------|
| L6-02 (04A2) | Torque Detection Level 1 | <div style="display: flex; gap: 5px;"> <span>V/f</span> <span>CL-V/f</span> <span>OLV</span> <span>CLV</span> <span>AOLV</span> <span>OLV/PM</span> <span>AOLV/PM</span> <span>CLV/PM</span> <span>EZOLV</span> </div> <p>Sets the detection level for Overtorque/Undertorque Detection 1. In V/f control, drive rated output current = 100% value. In vector control, motor rated torque = 100% value.</p> | 150%<br>(0 - 300%) |

#### Note:

- Set the torque detection level as a percentage of the drive rated output current in all control methods to set the mechanical weakening detection level.
- You can also use an analog input terminal to supply the torque detection level. To enable this function, set  $H3-xx = 7$  [*MFAI Function Select = Overtorque/Undertorque DetectLvl*]. If you set  $L6-02$  and  $H3-x = 7$ , the analog input is most important and the drive disables  $L6-02$ .

### ■ L6-03: Torque Detection Time 1

| No. (Hex.)   | Name                    | Description   | Default (Range)         |
|--------------|-------------------------|---|-------------------------|
| L6-03 (04A3) | Torque Detection Time 1 | <div style="display: flex; gap: 5px;"> <span>V/f</span> <span>CL-V/f</span> <span>OLV</span> <span>CLV</span> <span>AOLV</span> <span>OLV/PM</span> <span>AOLV/PM</span> <span>CLV/PM</span> <span>EZOLV</span> </div> <p>Sets the detection time for Overtorque/Undertorque Detection 1.</p> | 0.1 s<br>(0.0 - 10.0 s) |

### ■ L6-04: Torque Detection Selection 2

| No. (Hex.)   | Name                         | Description  | Default (Range) |
|--------------|------------------------------|--|-----------------|
| L6-04 (04A4) | Torque Detection Selection 2 | <div style="display: flex; gap: 5px;"> <span>V/f</span> <span>CL-V/f</span> <span>OLV</span> <span>CLV</span> <span>AOLV</span> <span>OLV/PM</span> <span>AOLV/PM</span> <span>CLV/PM</span> <span>EZOLV</span> </div> <p>Sets the speed range that detects overtorque and undertorque and the operation of drives (operation status) after detection.</p> | 0<br>(0 - 8)    |

The drive detects overtorque if the motor current or output torque is more than the level set in  $L6-05$  [*Torque Detection Level 2*] for the length of time set in  $L6-06$  [*Torque Detection Time 2*]. The drive detects undertorque if the motor current or output torque is less than the level set in  $L6-05$  for the length the time set in  $L6-06$ .

#### 0 : Disabled

The drive will not detect overtorque or undertorque.

#### 1 : oL @ Speed Agree - Alarm only

The drive detects overtorque when the output frequency aligns with the frequency reference. Detection does not occur during acceleration/deceleration. The drive outputs an *oL4* [*Overtorque Detection 2*] and operation continues.

#### 2 : oL @ RUN - Alarm only

When the Run command is enabled, the drive constantly detects overtorque. The drive outputs an *oL4* and operation continues.

#### 3 : oL @ Speed Agree - Fault

## 2.9 L: Protection Functions

The drive detects overtorque when the output frequency aligns with the frequency reference. Detection does not occur during acceleration/deceleration. The drive outputs an *oL4* [Overtorque Detection 2] and operation stops.

### 4 : oL @ RUN - Fault

When the Run command is enabled, the drive constantly detects overtorque. The drive outputs an *oL4* and operation stops.

### 5 : UL @ Speed Agree - Alarm only

The drive detects undertorque when the output frequency aligns with the frequency reference. Detection does not occur during acceleration/deceleration. The drive outputs a *UL4* [Undertorque Detection 2] and operation continues.

### 6 : UL @ RUN - Alarm only

When the Run command is enabled, the drive constantly detects undertorque. The drive outputs a *UL4* and operation continues.

### 7 : UL @ Speed Agree - Fault

The drive detects undertorque when the output frequency aligns with the frequency reference. Detection does not occur during acceleration/deceleration. The drive outputs a *UL4* and operation stops.

### 8 : UL @ RUN - Fault

When the Run command is enabled, the drive constantly detects undertorque. The drive outputs a *UL4* and operation stops.

## ■ L6-05: Torque Detection Level 2

| No. (Hex.)   | Name                     | Description   | Default (Range)    |
|--------------|--------------------------|---|--------------------|
| L6-05 (04A5) | Torque Detection Level 2 | <div style="display: flex; gap: 5px;"> <span>V/f</span> <span>CL-V/f</span> <span>OLV</span> <span>CLV</span> <span>AOLV</span> <span>OLV/PM</span> <span>AOLV/PM</span> <span>CLV/PM</span> <span>EZOLV</span> </div> <p>Sets the detection level for Overtorque/Undertorque Detection 2. In V/f control, drive rated output current = 100% value. In vector control, motor rated torque = 100% value.</p> | 150%<br>(0 - 300%) |

#### Note:

Overtorque/Undertorque Detection 2 cannot set the detection level for the analog input terminal.

## ■ L6-06: Torque Detection Time 2

| No. (Hex.)   | Name                    | Description   | Default (Range)         |
|--------------|-------------------------|---|-------------------------|
| L6-06 (04A6) | Torque Detection Time 2 | <div style="display: flex; gap: 5px;"> <span>V/f</span> <span>CL-V/f</span> <span>OLV</span> <span>CLV</span> <span>AOLV</span> <span>OLV/PM</span> <span>AOLV/PM</span> <span>CLV/PM</span> <span>EZOLV</span> </div> <p>Sets the detection time for Overtorque/Undertorque Detection 2.</p> | 0.1 s<br>(0.0 - 10.0 s) |

## ■ L6-07: Torque Detection Filter Time

| No. (Hex.)   | Name                         | Description   | Default (Range)       |
|--------------|------------------------------|---|-----------------------|
| L6-07 (04E5) | Torque Detection Filter Time | <div style="display: flex; gap: 5px;"> <span>V/f</span> <span>CL-V/f</span> <span>OLV</span> <span>CLV</span> <span>AOLV</span> <span>OLV/PM</span> <span>AOLV/PM</span> <span>CLV/PM</span> <span>EZOLV</span> </div> <p>Sets the time constant for a primary filter to the torque reference or to the output current used to detect overtorque/undertorque.</p> | 0 ms<br>(0 - 1000 ms) |

## ■ L6-08: Mechanical Fatigue Detect Select

| No. (Hex.)   | Name                             | Description  | Default (Range) |
|--------------|----------------------------------|--|-----------------|
| L6-08 (0468) | Mechanical Fatigue Detect Select | <div style="display: flex; gap: 5px;"> <span>V/f</span> <span>CL-V/f</span> <span>OLV</span> <span>CLV</span> <span>AOLV</span> <span>OLV/PM</span> <span>AOLV/PM</span> <span>CLV/PM</span> <span>EZOLV</span> </div> <p>Sets the speed where the drive detects mechanical deterioration and how the drive operates (operation status) after detection.</p> | 0<br>(0 - 8)    |

The drive detects mechanical weakening through overtorque or undertorque as specified by the conditions set in *L6-08 to L6-11* [Mechanical Deterioration Detection Settings Parameters]. Set overtorque/undertorque detection conditions in *L6-01 to L6-03* [Torque Detection 1 Settings Parameters]. The drive disables the operation selection set in *L6-01* [Torque Detection Selection 1].

### 0 : Disabled

The drive does not detect mechanical weakening.

**1 : oL5 @ Speed > L6-09 - Alarm**

When the speed (signed)  $\geq L6-09$  [Mech Fatigue Detect Speed Level], the drive detects mechanical weakening. The drive will detect oL5 [Mechanical Weakening Detection 1] and continue operation.

**2 : oL5 @ |Speed| > L6-09 - Alarm**

When the speed (absolute value)  $\geq L6-09$ , the drive detects mechanical weakening. The drive will detect oL5 and continue operation.

**3 : oL5 @ Speed > L6-09 - Fault**

When the speed (signed)  $\geq L6-09$ , the drive detects mechanical weakening. The drive will detect oL5 and stop operation.

**4 : oL5 @ |Speed| > L6-09 - Fault**

When the speed (absolute value)  $\geq L6-09$ , the drive detects mechanical weakening. The drive will detect oL5 and stop operation.

**5 : UL5 @ Speed < L6-09 - Alarm**

When the speed (signed)  $\leq L6-09$ , the drive detects mechanical weakening. The drive will detect UL5 [Mechanical Weakening Detection 2] and continue operation.

**6 : UL5 @ |Speed| < L6-09 - Alarm**

When the speed (absolute value)  $\leq L6-09$ , the drive detects mechanical weakening. The drive will detect UL5 and continue operation.

**7 : UL5 @ Speed < L6-09 - Fault**

When the speed (signed)  $\leq L6-09$ , the drive detects mechanical weakening. The drive will detect UL5 and stop operation.

**8 : UL5 @ |Speed| < L6-09 - Fault**

When the speed (absolute value)  $\leq L6-09$ , the drive detects mechanical weakening. The drive will detect UL5 and stop operation.

**■ L6-09: Mech Fatigue Detect Speed Level**

| No. (Hex.)   | Name                            | Description   | Default (Range)             |
|--------------|---------------------------------|---|-----------------------------|
| L6-09 (0469) | Mech Fatigue Detect Speed Level | <b>V/f</b> <b>CL-V/f</b> <b>OLV</b> <b>CLV</b> <b>AOLV</b> <b>OLV/PM</b> <b>AOLV/PM</b> <b>CLV/PM</b> <b>EZOLV</b><br>Sets the speed level where the drive will operate the mechanical deterioration detection function, as a percentage of the Maximum Output Frequency. | 110.0%<br>(-110.0 - 110.0%) |

Parameters L6-01 to L6-03 [Torque Detection 1 Settings Parameters] set the overtorque/undertorque detection conditions.

When L6-08 = 2, 4, 6, 8 [Mechanical Fatigue Detect Select = Speed : unsigned], the setting value of L6-09 is the absolute value. When L6-09 is set to a negative number, the drive processes this value as a positive number.

**■ L6-10: Mech Fatigue Detect Delay Time**

| No. (Hex.)   | Name                           | Description   | Default (Range)         |
|--------------|--------------------------------|---|-------------------------|
| L6-10 (046A) | Mech Fatigue Detect Delay Time | <b>V/f</b> <b>CL-V/f</b> <b>OLV</b> <b>CLV</b> <b>AOLV</b> <b>OLV/PM</b> <b>AOLV/PM</b> <b>CLV/PM</b> <b>EZOLV</b><br>Sets the time for mechanical deterioration detection. | 0.1 s<br>(0.0 - 10.0 s) |

When the detection conditions set in L6-08 [Mechanical Weakening Detect Ope] continue for the time set in L6-10, the drive will detect mechanical weakening.

**■ L6-11: Mech Fatigue Hold Off Time**

| No. (Hex.)   | Name                       | Description   | Default (Range)      |
|--------------|----------------------------|---|----------------------|
| L6-11 (046B) | Mech Fatigue Hold Off Time | <b>V/f</b> <b>CL-V/f</b> <b>OLV</b> <b>CLV</b> <b>AOLV</b> <b>OLV/PM</b> <b>AOLV/PM</b> <b>CLV/PM</b> <b>EZOLV</b><br>Sets the time that the drive will start mechanical deterioration detection triggered by the cumulative operation time of the drive. | 0 h<br>(0 - 65535 h) |

## 2.9 L: Protection Functions

When the total operation time of the drive is more than the value set in *L6-11*, the drive will detect mechanical weakening. Use *U4-01 [Cumulative Ope Time]* to monitor the drive total operation time.

### ◆ L7: Torque Limit

The torque limit function limits the internal torque reference for the drive to limit the quantity of torque generated by the motor to a constant quantity. This function keeps the torque applied to loads and regenerative torque less than a set quantity. This function also prevents damage to machinery and increases the reliability of continuous operation. You can set torque limits individually for the four quadrants, which include torque direction (motoring/regeneration) and direction of motor rotation (forward/reverse). When the torque reference value is at the set torque limit, the MFDO terminal set for *During Torque Limit [H2-xx = 30]* activates.

**Note:**

- The drive output current limits maximum output torque. The drive limits torque to 150% of the rated output current for Heavy Duty Rating (HD) and to 110% of the rated output current for Normal Duty Rating (ND). The actual output torque is not more than the limits of the drive rated output current when you set the torque limit to a high value.
- When you use torque limits for lifting applications, do not lower the torque limit value too much. When the torque limit function is triggered, falls and rollbacks can occur because of sudden acceleration stops and stalls of the motor.

### ■ Configuring Settings

Use one of these methods to set torque limits:

- Individually set the four torque limit quadrants using *L7-01 to L7-04 [Torque Limit]*.
- Use MFAI to individually set the four torque limit quadrants. Set *H3-02, H3-06, H3-10 = 10, 11, 12 [MFAI Function Select = Forward/Reverse/Regenerative Torque Limit]*.
- Use MFAI to set all four torque limit quadrants together. Set *H3-02, H3-06, H3-10 = 15 [General Torque Limit]*.
- Use a communication option to set all four torque limit quadrants together.

Figure 2.141 shows the configuration method for each quadrant.

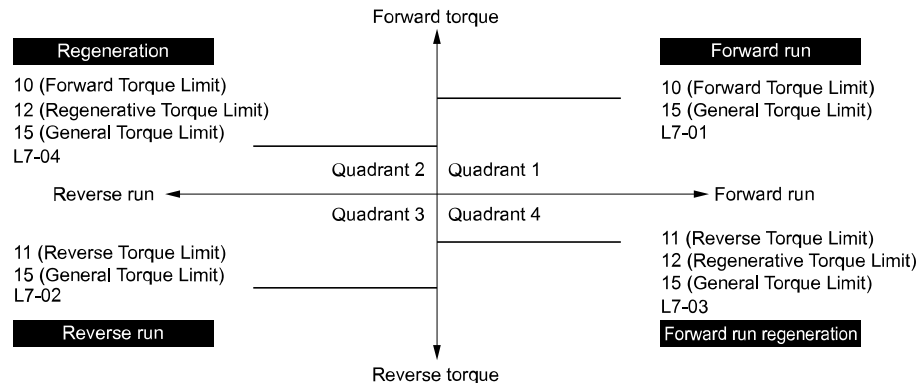


Figure 2.141 Torque Limits and Analog Input Setting Parameters

**Note:**

- When *L7-01 to L7-04* and analog inputs or communication option torque limits set torque limits for the same quadrant, the lower value is enabled. In this example of parameter settings, the torque limit for quadrant 1 is 130% and the torque limit for quadrants 2, 3, and 4 is 150%. Settings: *L7-01 = 130%*, *L7-02 to L7-04 = 200%*, and MFAI torque limit = 150%
- The drive output current limits maximum output torque. The torque limit is 150% of the rated output current for HD and to 120% of the rated output current for ND. The actual output torque is not more than the limits of the drive rated output current when you set the torque limit to a high value.

### ■ L7-01: Forward Torque Limit

| No. (Hex.)             | Name                 | Description   | Default (Range)    |
|------------------------|----------------------|---|--------------------|
| L7-01<br>(04A7)<br>RUN | Forward Torque Limit | <div style="display: flex; gap: 5px;"> <span>V/f</span> <span>CL-V/f</span> <span>OLV</span> <span>CLV</span> <span>AOLV</span> <span>OLV/PM</span> <span>AOLV/PM</span> <span>CLV/PM</span> <span>EZOLV</span> </div> <p>Sets the torque limit value for forward motoring as a percentage, where motor rated torque is the 100% value.</p> | 200%<br>(0 - 300%) |

**Note:**

- The lower torque limit is enabled when you set the torque limit by the following method.
  - Set H3-02, H3-06, or H3-10 = 10, 15 [MFAI Function Select = Forward, Reverse/Regenerative Torque Limit].
  - Use a communication option to set the torque limits
- You must think about drive capacity when a large quantity of torque is necessary. If you set the value too high, the drive can detect *oC* [Overcurrent].
- If you set the value too low with large loads, the motor can stall.

**■ L7-02: Reverse Torque Limit**

| No. (Hex.)             | Name                 | Description  | Default (Range)    |
|------------------------|----------------------|--|--------------------|
| L7-02<br>(04A8)<br>RUN | Reverse Torque Limit | V/f CL-V/f <b>OLV</b> CLV AOLV OLV/PM AOLV/PM CLV/PM EZOLV<br>Sets the torque limit value for reversed motoring as a percentage, where motor rated torque is the 100% value. | 200%<br>(0 - 300%) |

**Note:**

- The lower torque limit is enabled when you set the torque limit by the following method.
  - Set H3-02, H3-06, or H3-10 = 10, 15 [MFAI Function Select = Forward, Reverse/Regenerative Torque Limit].
  - Use a communication option to set the torque limits
- You must think about drive capacity when a large quantity of torque is necessary. If you set the value too high, the drive can detect *oC* [Overcurrent].
- If you set the value too low with large loads, the motor can stall.

**■ L7-03: Forward Regenerative Trq Limit**

| No. (Hex.)             | Name                           | Description  | Default (Range)    |
|------------------------|--------------------------------|--|--------------------|
| L7-03<br>(04A9)<br>RUN | Forward Regenerative Trq Limit | V/f CL-V/f <b>OLV</b> CLV AOLV OLV/PM AOLV/PM CLV/PM EZOLV<br>Sets the torque limit value for forward regenerative conditions as a percentage of the motor rated torque. | 200%<br>(0 - 300%) |

**Note:**

- The lower torque limit is enabled when you set the torque limit by the following method.
  - Set H3-02, H3-06, or H3-10 = 10, 15 [MFAI Function Select = Forward, Reverse/Regenerative Torque Limit].
  - Use a communication option to set the torque limits
- You must think about drive capacity when a large quantity of torque is necessary. If you set the value too high, the drive can detect *oC* [Overcurrent].
- If you set the value too low with large loads, the motor can stall.

**■ L7-04: Reverse Regenerative Trq Limit**

| No. (Hex.)             | Name                           | Description   | Default (Range)    |
|------------------------|--------------------------------|---|--------------------|
| L7-04<br>(04AA)<br>RUN | Reverse Regenerative Trq Limit | V/f CL-V/f <b>OLV</b> CLV AOLV OLV/PM AOLV/PM CLV/PM EZOLV<br>Sets the torque limit value for reversed regenerative conditions as a percentage of the motor rated torque. | 200%<br>(0 - 300%) |

**Note:**

- The lower torque limit is enabled when you set the torque limit by the following method.
  - Set H3-02, H3-06, or H3-10 = 10, 15 [MFAI Function Select = Forward, Reverse/Regenerative Torque Limit].
  - Use a communication option to set the torque limits
- You must think about drive capacity when a large quantity of torque is necessary. If you set the value too high, the drive can detect *oC* [Overcurrent].
- If you set the value too low with large loads, the motor can stall.

**■ L7-06: Torque Limit Integral Time**

| No. (Hex.)      | Name                       | Description  | Default (Range)          |
|-----------------|----------------------------|--|--------------------------|
| L7-06<br>(04AC) | Torque Limit Integral Time | V/f CL-V/f <b>OLV</b> CLV AOLV OLV/PM AOLV/PM CLV/PM EZOLV<br>Sets the integral time constant for the torque limit function. | 200 ms<br>(5 - 10000 ms) |

## 2.9 L: Protection Functions

Decrease the setting value to increase torque limit responsiveness when you use torque limits and  $L7-07 = 1$  [*Torque Limit during Accel/Decel = Proportional & Integral control*].

If there is hunting when torque limits are active, increase the setting value.

### ■ L7-07: Torque Limit during Accel/Decel

| No. (Hex.)   | Name                            | Description  | Default (Range) |
|--------------|---------------------------------|--|-----------------|
| L7-07 (04C9) | Torque Limit during Accel/Decel | V/f CL-V/f <b>OLV</b> CLV AOLV OLV/PM AOLV/PM CLV/PM EZOLV<br>Sets the torque limit function during acceleration and deceleration. | 0<br>(0, 1)     |

#### 0 : Proportional only

The torque limit function works with proportional control during acceleration and deceleration, and switches to integral control at constant speed. Use this setting when quickly reaching the target speed is more important than the torque limit during speed changes.

#### 1 : Proportional & Integral control

The torque limit function always uses integral control. Use this setting when a very accurate torque limit is necessary during speed changes, for example in winding machine applications.

If you make the torque limit the most important, it can:

- Increase the acceleration and deceleration times.
- Not let the motor speed reach the frequency reference value during run at constant speed.

### ■ L7-16: Torque Limit Process at Start

| No. (Hex.)   | Name                          | Description   | Default (Range) |
|--------------|-------------------------------|---|-----------------|
| L7-16 (044D) | Torque Limit Process at Start | V/f CL-V/f <b>OLV</b> <b>CLV</b> AOLV OLV/PM AOLV/PM CLV/PM EZOLV<br>Assigns a time filter to allow the torque limit to build at start. | 1<br>(0, 1)     |

#### 0 : Disabled

There is torque limit at start without a delay time.

Use this setting to maximize the response time when sudden acceleration or deceleration at start is necessary.

#### 1 : Enabled

There is a delay time of 64 ms at start to build the torque limit.

### ■ L7-35: Low Freq Regen Torque Limit Lvl

| No. (Hex.)             | Name                            | Description   | Default (Range)         |
|------------------------|---------------------------------|---|-------------------------|
| L7-35 (1B57)<br>Expert | Low Freq Regen Torque Limit Lvl | V/f CL-V/f OLV CLV <b>AOLV</b> OLV/PM AOLV/PM CLV/PM EZOLV<br>Sets the torque limit used during low-speed regeneration. Usually it is not necessary to change this setting. | 50.0%<br>(0.0 - 200.0%) |

Reduces the regenerative torque limit to the level set with  $L7-35$  when using low frequencies such that the output frequency is less than  $L7-36$  [*Regen Torque Limit Derate Freq*]. The drive does not decrease torque limits during ramp to stop operation. Decrease the setting of  $L7-35$  when  $oC$  [*Overcurrent*] issues occur while a regenerative load is input and the speed reference is constant.

#### Note:

- Reduce the setting value of  $L7-35$  in increments of 10.0% and reduce the setting value of  $L7-36$  in increments of 2.0 Hz when faults occur during regenerative loads at low speed.
- Setting values that are too high can cause faults.
- The torque limit reduction function does not operate when  $L7-35$  is set with a value larger than  $L7-03$  [*Forward Regenerative Trq Limit*] or  $L7-04$  [*Reverse Regenerative Trq Limit*].
- The motor may rotate slightly faster than the reference when a regenerative load is input at low speeds while  $L7-35$  is set to a low value.

### ■ L7-36: Regen Torque Limit Derate Freq

| No.<br>(Hex.)             | Name                           | Description  | Default<br>(Range)        |
|---------------------------|--------------------------------|--|---------------------------|
| L7-36<br>(1B58)<br>Expert | Regen Torque Limit Derate Freq | V/f CL-V/f OLV CLV AOLV OLV/PM AOLV/PM CLV/PM EZOLV<br>Sets the frequency width at which L7-35 [Low Freq Regen Torque Limit Lvl] operates. | 6.0 Hz<br>(0.0 - 30.0 Hz) |

If the drive detects *oC* [Overcurrent] faults when you connect regenerative loads at low speed, increase the setting value. Decreases the torque limit as specified by the setting of L7-35 in a range of  $0 \leq \text{output frequency} < L7-36$ . When the torque limit gradually changes as specified by the output frequency until the output frequency = L7-36, the value changes to the settings of L7-03 [Forward Regenerative Trq Limit] and L7-04 [Reverse Regenerative Trq Limit].

**Note:**

Increasing the setting of L7-36 causes the motor to rotate at a speed higher than specified when a regenerative load is input. Do not set the value higher than necessary.

### ◆ L8: Drive Protection

L8 parameters set protective functions that prevent faults such as overheating, phase loss, and ground faults.

#### ■ L8-01: 3% ERF DB Resistor Protection

| No.<br>(Hex.)   | Name                          | Description  | Default<br>(Range) |
|-----------------|-------------------------------|--|--------------------|
| L8-01<br>(04AD) | 3% ERF DB Resistor Protection | V/f CL-V/f OLV CLV AOLV OLV/PM AOLV/PM CLV/PM EZOLV<br>Sets the function to enable braking resistor protection with a Yaskawa ERF series braking resistor (3% ED) installed on the heatsink. | 0<br>(0, 1)        |

#### 0 : Disabled

Disables braking resistor protection. Use this setting for dynamic braking options that are not Yaskawa ERF series braking resistors.

#### 1 : Enabled

Enables protection for Yaskawa ERF series braking resistors.

**Note:**

Set L8-01 = 1 and H2-01 to H2-03 = D [MFDO Function Select = Braking Resistor Fault]. Use a sequence to turn OFF power with MFDO.

#### ■ L8-02: Overheat Alarm Level

| No.<br>(Hex.)   | Name                 | Description   | Default<br>(Range)                          |
|-----------------|----------------------|---|---|
| L8-02<br>(04AE) | Overheat Alarm Level | V/f CL-V/f OLV CLV AOLV OLV/PM AOLV/PM CLV/PM EZOLV<br>Sets the <i>oH</i> detection level in temperature. | Determined by o2-04, C6-01<br>(50 - 150 °C) |

If the heatsink temperature is more than the temperature set in this parameter, the drive detects an overheat pre-alarm. To enable this function, set one of H2-01 to H2-03 [MFDO Function Select] to 20 [Drive Overheat Pre-Alarm (*oH*)].

If the temperature increases to the overheat fault level, the drive will trigger an *oH1* [Heatsink Overheat] fault and stop operation.

#### ■ L8-03: Overheat Pre-Alarm Selection

| No.<br>(Hex.)   | Name                         | Description  | Default<br>(Range) |
|-----------------|------------------------------|--|--------------------|
| L8-03<br>(04AF) | Overheat Pre-Alarm Selection | V/f CL-V/f OLV CLV AOLV OLV/PM AOLV/PM CLV/PM EZOLV<br>Sets the operation of drives when an <i>oH</i> alarm is detected. | 3<br>(0 - 4)       |

#### 0 : Ramp to Stop

The drive ramps the motor to stop in the deceleration time. Fault relay output terminal MA-MC turns ON, and MB-MC turns OFF.

## 2.9 L: Protection Functions

### 1 : Coast to Stop

The output turns off and the motor coasts to stop. Fault relay output terminal MA-MC turns ON, and MB-MC turns OFF.

### 2 : Fast Stop

The drive stops the motor in the deceleration time set in *C1-09 [Fast Stop Time]*. Fault relay output terminal MA-MC turns ON, and MB-MC turns OFF.

### 3 : Alarm Only

The keypad shows *oH* and the drive continues operation. The output terminal set for *Alarm [H2-01 to H2-03 = 10]* turns ON.

### 4 : Operate at Reduced Speed (L8-19)

The drive decelerates to the level set in *L8-19 [Freq Reduction @ oH Pre-Alarm]* and continues operation. *oH* flashes on the keypad.

*oH* flashes on the keypad. When the alarm is output, the drive decelerates each 10 seconds. If the drive decelerates 10 times and the alarm continues to be output, the output terminal set for *oH Pre-Alarm Reduction Limit [H2-01 to H2-03 = 4D]* activates. When the alarm is not output during deceleration, the drive accelerates until it is at the frequency reference that was applicable before the alarm was turned off. Figure 2.142 shows the output of the alarm and the drive operation at a decreased output frequency.

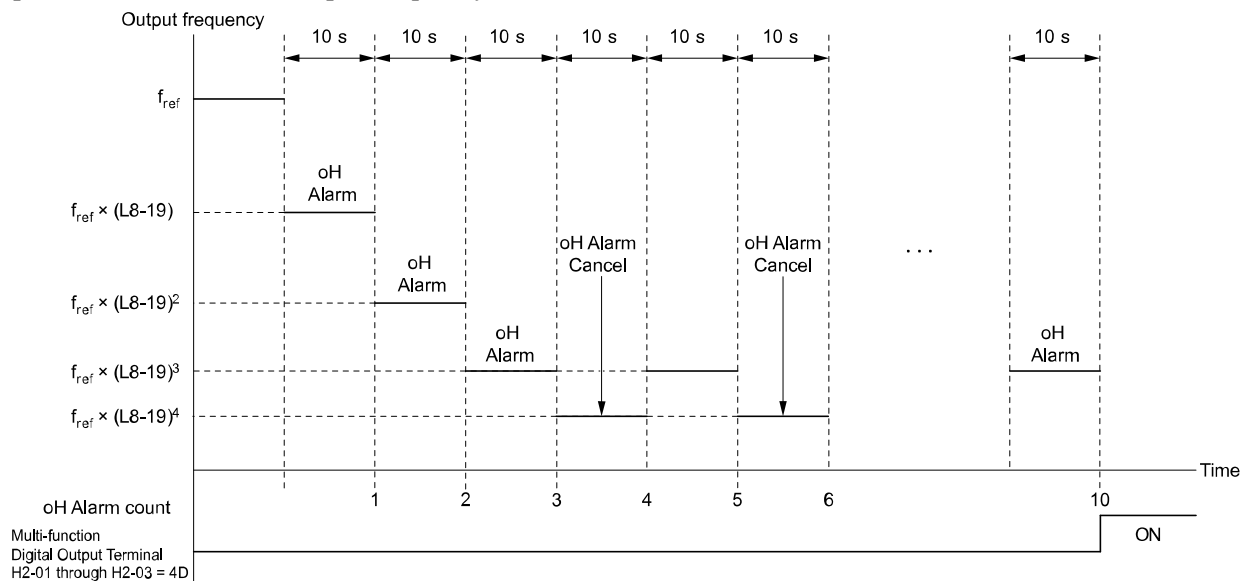


Figure 2.142 Drive Operation at a Decreased Output Frequency when the Overheat Alarm is Output

## ■ L8-05: Input Phase Loss Protection Sel

| No. (Hex.)   | Name                            | Description   | Default (Range) |
|--------------|---------------------------------|---|-----------------|
| L8-05 (04B1) | Input Phase Loss Protection Sel | <input type="checkbox"/> V/f <input type="checkbox"/> CL-V/f <input type="checkbox"/> OLV <input type="checkbox"/> CLV <input type="checkbox"/> AOLV <input type="checkbox"/> OLV/PM <input type="checkbox"/> AOLV/PM <input type="checkbox"/> CLV/PM <input type="checkbox"/> EZOLV<br>Sets the function to enable and disable input phase loss detection. | 1<br>(0, 1)     |

### 0 : Disabled

### 1 : Enabled

The drive measures ripples in DC bus voltage to detect input phase loss.

The drive detects phase loss when power supply phase loss occurs or the main circuit capacitor becomes unusable, which causes *PF [Input Phase Loss]* to show on the keypad.

Disable the detection of the input power supply phase loss function in these conditions:

- During deceleration
- The run command is not input
- The output current is less than 30% of the drive rated current.



### ■ L8-07: Output Phase Loss Protection Sel

| No.<br>(Hex.)   | Name                             | Description   | Default<br>(Range) |
|-----------------|----------------------------------|---|--------------------|
| L8-07<br>(04B3) | Output Phase Loss Protection Sel | <div style="display: flex; gap: 5px;"> <span>V/f</span> <span>CL-V/f</span> <span>OLV</span> <span>CLV</span> <span>AOLV</span> <span>OLV/PM</span> <span>AOLV/PM</span> <span>CLV/PM</span> <span>EZOLV</span> </div> <p>Sets the function to enable and disable output phase loss detection. The drive starts output phase loss detection when the output current decreases to less than 5% of the drive rated current.</p> | 1<br>(0 - 2)       |

**Note:**

The drive can incorrectly start output phase loss detection in these conditions:

- The motor rated current is very small compared to the drive rating.
- The drive is operating a PM motor with a small load.

#### 0 : Disabled

#### 1 : Fault when one phase is lost

If the drive loses one output phase, it will trigger *LF* [Output Phase Loss].

The output turns off and the motor coasts to stop.

#### 2 : Fault when two phases are lost

If the drive loses more than one output phase, it will trigger *LF* [Output Phase Loss].

The output turns off and the motor coasts to stop.

### ■ L8-09: Output Ground Fault Detection

| No.<br>(Hex.)   | Name                          | Description  | Default<br>(Range)            |
|-----------------|-------------------------------|--|-------------------------------|
| L8-09<br>(04B5) | Output Ground Fault Detection | <div style="display: flex; gap: 5px;"> <span>V/f</span> <span>CL-V/f</span> <span>OLV</span> <span>CLV</span> <span>AOLV</span> <span>OLV/PM</span> <span>AOLV/PM</span> <span>CLV/PM</span> <span>EZOLV</span> </div> <p>Sets the function to enable and disable ground fault protection.</p> | Determined by o2-04<br>(0, 1) |

#### 0 : Disabled

The drive will not detect ground faults.

#### 1 : Enabled

If there is high leakage current or a ground short circuit in one or two output phases, the drive will detect *GF* [Ground Fault].

**Note:**

If the ground path impedance is low, *oC* [Overcurrent], *SC* [Out Short Circuit or IGBT Fault], or *ov* [DC Bus Overvoltage] can stop the motor.

### ■ L8-10: Heatsink Fan Operation Selection

| No.<br>(Hex.)   | Name                             | Description   | Default<br>(Range) |
|-----------------|----------------------------------|---|--------------------|
| L8-10<br>(04B6) | Heatsink Fan Operation Selection | <div style="display: flex; gap: 5px;"> <span>V/f</span> <span>CL-V/f</span> <span>OLV</span> <span>CLV</span> <span>AOLV</span> <span>OLV/PM</span> <span>AOLV/PM</span> <span>CLV/PM</span> <span>EZOLV</span> </div> <p>Sets operation of the heatsink cooling fan.</p> | 0<br>(0 - 2)       |

#### 0 : During Run, w/ L8-11 Off-Delay

The drive turns on the fan when a Run command is active.

#### 1 : Always On

The fan turns on when you supply power to the drive. When you release the Run command and the delay time set in *L8-11* [HeatsinkCoolingFan Off DelayTime] is expired, the fan stops. This setting extends the fan lifetime.

#### 2 : On when Drive Temp Reaches L8-64

The fan turns on when the drive detects that the main circuit is overheating.

## 2.9 L: Protection Functions

### ■ L8-11: Heatsink Fan Off-Delay Time

| No.<br>(Hex.)   | Name                        | Description   | Default<br>(Range)  |
|-----------------|-----------------------------|---|---------------------|
| L8-11<br>(04B7) | Heatsink Fan Off-Delay Time | <b>V/f</b> <b>CL-V/f</b> <b>OLV</b> <b>CLV</b> <b>AOLV</b> <b>OLV/PM</b> <b>AOLV/PM</b> <b>CLV/PM</b> <b>EZOLV</b><br>Sets the length of time that the drive will wait before stopping the cooling fan after canceling the Run command when L8-10 = 0 [Heatsink Cooling Fan Ope Select = Dur Run (OffDly)]. | 60 s<br>(0 - 300 s) |

### ■ L8-12: Ambient Temperature Setting

| No.<br>(Hex.)   | Name                        | Description  | Default<br>(Range)      |
|-----------------|-----------------------------|--|-------------------------|
| L8-12<br>(04B8) | Ambient Temperature Setting | <b>V/f</b> <b>CL-V/f</b> <b>OLV</b> <b>CLV</b> <b>AOLV</b> <b>OLV/PM</b> <b>AOLV/PM</b> <b>CLV/PM</b> <b>EZOLV</b><br>Sets the ambient temperature of the drive installation area. | 40 °C<br>(-10 - +50 °C) |

The drive automatically adjusts the drive rated current to the best value as specified by the set temperature. Set the ambient temperature of the area where you install the drive to a value that is more than the drive rating.

Refer to **Missing reference ID** for information on derating depending on ambient temperature.

### ■ L8-15: Drive oL2 @ Low Speed Protection

| No.<br>(Hex.)   | Name                             | Description   | Default<br>(Range) |
|-----------------|----------------------------------|---|--------------------|
| L8-15<br>(04BB) | Drive oL2 @ Low Speed Protection | <b>V/f</b> <b>CL-V/f</b> <b>OLV</b> <b>CLV</b> <b>AOLV</b> <b>OLV/PM</b> <b>AOLV/PM</b> <b>CLV/PM</b> <b>EZOLV</b><br>Sets the function to decrease drive overload at low speeds to prevent damage to the main circuit transistor during low speed operation (at 6 Hz or slower) to prevent oL2 [Drive Overloaded]. | 1<br>(0, 1)        |

**Note:**

Contact Yaskawa or your nearest sales representative for consultation before disabling this function at low speeds. Frequent operation of drives under conditions of high output current in low speed ranges may shorten the service life of the drive IGBT due to heat stress.

#### 0 : Disabled (No Additional Derate)

The drive does not decrease the overload protection level.

#### 1 : Enabled (Reduced oL2 Level)

When the drive detects oL2 during low speed operation, it automatically decreases the overload detection level.

At zero speed, the drive derates the overload by 50%.

### ■ L8-18: Software Current Limit Selection

| No.<br>(Hex.)   | Name                             | Description  | Default<br>(Range) |
|-----------------|----------------------------------|--|--------------------|
| L8-18<br>(04BE) | Software Current Limit Selection | <b>V/f</b> <b>CL-V/f</b> <b>OLV</b> <b>CLV</b> <b>AOLV</b> <b>OLV/PM</b> <b>AOLV/PM</b> <b>CLV/PM</b> <b>EZOLV</b><br>Set the software current limit selection function to prevent damage to the main circuit transistor caused by too much current. | 0<br>(0, 1)        |

#### 0 : Disabled

When the output current is at the software current limit value, the drive does not restrict the output voltage.

**Note:**

The drive may detect an oC [Overcurrent] when loads are particularly heavy or the acceleration time is particularly short.

#### 1 : Enabled

When the output current is at the software current limit value, the drive decreases output voltage to decrease output current.

When the output current decreases to the software current limit level, the drive starts usual operation.

### ■ L8-19: Freq Reduction @ oH Pre-Alarm

| No.<br>(Hex.)   | Name                          | Description   | Default<br>(Range) |
|-----------------|-------------------------------|---|--------------------|
| L8-19<br>(04BF) | Freq Reduction @ oH Pre-Alarm | <b>V/f</b> <b>CL-V/f</b> <b>OLV</b> <b>CLV</b> <b>AOLV</b> <b>OLV/PM</b> <b>AOLV/PM</b> <b>CLV/PM</b> <b>EZOLV</b><br>Sets the ratio at which the drive derates the frequency reference during an oH alarm. | 0.8<br>(0.1 - 0.9) |

When these two conditions are correct, this function is enabled:

- $L8-03 = 4$  [Overheat Pre-Alarm Ope Selection = Run@L8-19 Rate]
- *oH* alarm is output

■ **L8-20: Control Fault & Step Out Detect**

| No. (Hex.)          | Name                            | Description  | Default (Range) |
|---------------------|---------------------------------|--|-----------------|
| L8-20 (04C0) Expert | Control Fault & Step Out Detect | V/f CL-V/f OLV CLV <b>AOLV</b> OLV/PM AOLV/PM CLV/PM EZOLV<br>Sets operation after the drive detects a CF fault when $A1-02 = 4$ [Control Method Selection = Advanced Open Loop Vector]. | 1 (0 - 2)       |

If you enter a Stop command but it cannot stop drive operation, the drive will detect CF.

**0 : Disabled**

**1 : CF/STPo Detection Enabled**

**2 : CF ALM/Stop**

The drive stops DC injection braking as specified by the value of  $b2-03$  [DC Inject Braking Time at Start].

**Note:**

- If  $A1-02 = 4$  and you do not do Rotational Auto-Tuning, control will not be stable. This can cause CF faults when you ramp to stop. If the drive detects CF, do Rotational Auto-Tuning and Line-to-Line Resistance Tuning. Also, do Line-to-Line Resistance Tuning.
- If you set  $A1-02 = 4$  and configure the following, the drive may detect CF because of failing to stop the operation under particular load conditions. Make sure that you do Rotational Auto-Tuning and Line-to-Line Resistance Tuning correctly and then set  $L8-20 = 0$ .  
 – $d5-01 = 1$  [Torque Control Selection = Enabled]  
 – $L3-11 = 1$  [OV Suppression Function Select = Enabled]  
 –Decreased  $L7-01$  to  $L7-04$  [Torque Limit].

■ **L8-27: Overcurrent Detection Gain**

| No. (Hex.)   | Name                       | Description   | Default (Range)        |
|--------------|----------------------------|---|------------------------|
| L8-27 (04DD) | Overcurrent Detection Gain | V/f CL-V/f OLV CLV AOLV <b>OLV/PM</b> AOLV/PM CLV/PM EZOLV<br>Sets the PM motor overcurrent detection level as a percentage of the motor rated current value. | 300.0% (0.0 - 1000.0%) |

**Note:**

- The overcurrent detection function detects the lower of these two values:  
 –Drive overcurrent level  
 –Motor rated current  $\times L8-27 / 100$
- $L7-xx$  [Torque Limit] settings should be smaller than the setting of  $L8-27$ .
- For drives with software version PRG:1022 or later, this function is disabled when you set  $L8-27 = 0.0$ . Under normal circumstances, do not set  $L8-27 = 0.0$ . If the drive rated current is much higher than the motor rated current, PM motor magnets can demagnetize when current flows at the drive overcurrent detection level. The software version is indicated in the "PRG" column on the nameplate on the right side of the drive. You can also use  $U1-25$  [SoftwareNumber Flash] to check the software version.

■ **L8-29: Output Unbalance Detection Sel**

| No. (Hex.)   | Name                           | Description  | Default (Range) |
|--------------|--------------------------------|--|-----------------|
| L8-29 (04DF) | Output Unbalance Detection Sel | V/f CL-V/f OLV CLV AOLV <b>OLV/PM</b> AOLV/PM CLV/PM EZOLV<br>Sets the function to detect LF2. | 1 (0, 1)        |

This function prevents damage to PM motors. Current unbalance can heat a PM motor and demagnetize the magnets. When the current is unbalanced, the drive will detect LF2 to stop the motor and prevent damage to the motor.

**0 : No**

**1 : Yes**

## 2.9 L: Protection Functions

### ■ L8-31: LF2 Detection Time

| No.<br>(Hex.)   | Name               | Description   | Default<br>(Range) |
|-----------------|--------------------|---|--------------------|
| L8-31<br>(04E1) | LF2 Detection Time | V/f CL-V/f OLV CLV AOLV <b>OLV/PM</b> AOLV/PM CLV/PM EZOLV<br>Sets the LF2 [Output Current Imbalance] detection time. | 3<br>(1 to 100)    |

When the output current is unbalanced for longer than the time set in *L8-31*, the drive detects *LF2*.

**Note:**

- Set *L8-29* = 1 [*Current Unbalance Detect (LF2) = Enabled*] to enable *L8-31*.
- If the drive falsely detects *LF2*, increase the setting value of *L8-31* in 5-unit increments.
- The keypad shows *L8-31* when *E9-01* = 1 [*Motor Type Selection = PM*] under EZ Vector Control.

### ■ L8-35: Installation Method Selection

| No.<br>(Hex.)   | Name                          | Description  | Default<br>(Range)                 |
|-----------------|-------------------------------|--|------------------------------------|
| L8-35<br>(04EC) | Installation Method Selection | V/f CL-V/f OLV CLV AOLV <b>OLV/PM</b> AOLV/PM CLV/PM EZOLV<br>Sets the type of drive installation. | Determined by the drive<br>(0 - 3) |

**Note:**

- Parameter *A1-03* [*Initialize Parameters*] does not initialize this parameter.
- This parameter is set to the correct value when the drive is shipped. Side-by-Side installation  
–Change the value only in these conditions:  
–When you install a UL Type 1 kit on an open-chassis type (IP20) drive to convert the drive to a wall-mount enclosure (UL Type 1).

The overload protection detection level for the drive is automatically adjusted to the optimal value in accordance with the setting value. Refer to **Missing reference ID** for information on derating depending on ambient temperature.

#### 0 : IP20/OpenChassis Enc/Ex Heatsink

Use this setting to install an open-chassis type (IP20) drive or when the heatsink (cooling fin) is outside the enclosure panel.

Make sure that there is 30 mm (1.18 in) minimum of space between drives or between the drive and side of the enclosure panel.

#### 1 : Side-by-Side Mounting

Use this setting to install more than one drive Side-by-Side.

Make sure that there is 2 mm (0.08 in) minimum of space between drives.

#### 2 : IP21/NEMA Type 1/IP55

Use this setting to install UL Type 1 enclosed wall-mounted type drives or IP55 drives.

#### 3 : Finless

Use this setting to install a finless drive.

### ■ L8-38: Carrier Frequency Reduction

| No.<br>(Hex.)   | Name                        | Description  | Default<br>(Range)                              |
|-----------------|-----------------------------|--|---|
| L8-38<br>(04EF) | Carrier Frequency Reduction | V/f CL-V/f OLV CLV AOLV <b>OLV/PM</b> AOLV/PM CLV/PM EZOLV<br>Sets the carrier frequency reduction function. The drive reduces the carrier frequency when the output current is more than a specified level. | Determined by A1-02, C6-01 and o2-04<br>(0 - 2) |

If you decrease the carrier frequency, it increases the overload tolerance. The overload capacity increases temporarily for *oL2* [*Drive Overloaded*] and lets the drive operate through transient load peaks and not trip.

#### 0 : Disabled

The drive will not decrease the carrier frequency at high current.

#### 1 : Enabled below 6 Hz

The drive decreases the carrier frequency at speeds less than 6 Hz when the current is more than 100% of the drive rated current.

When the current is less than 88% or the output frequency is more than 7 Hz, the drive goes back to the usual carrier frequency.

## 2 : Enabled for All Speeds

The drive decreases the carrier frequency at these speeds:

- Output current is a minimum of 100% of the drive rated current and the frequency reference is less than 6 Hz.
- Output current is a minimum of 109% of the drive rated current, the drive is in Normal Duty mode, and the frequency reference is 7 Hz or more.
- Output current is a minimum of 112% of the drive rated current, the drive is in Heavy Duty mode, and the frequency reference is 7 Hz or more.

When the drive switches the carrier frequency to the set value, it uses the delay time set in *L8-40 [CarrierFreqReduct Off DelayTime]* and a hysteresis of 12%.

### ■ L8-40: Carrier Freq Reduction Off-Delay

| No. (Hex.)   | Name                             | Description  | Default (Range)                     |
|--------------|----------------------------------|--|-------------------------------------|
| L8-40 (04F1) | Carrier Freq Reduction Off-Delay | <b>V/f</b> <b>CL-V/f</b> <b>OLV</b> <b>CLV</b> <b>AOLV</b> <b>OLV/PM</b> <b>AOLV/PM</b> <b>CLV/PM</b> <b>EZOLV</b><br>Sets the length of time until the automatically reduced carrier frequency returns to the condition before the reduction. | Determined by A1-02 (0.00 - 2.00 s) |

Set *L8-40*  $\neq 0.00$  to enable the carrier frequency reduction function during start-up. When operation starts, the drive automatically decreases the carrier frequency. When the time set in *L8-40* is expired, the carrier frequency returns to the value set in *C6-02 [Carrier Frequency Selection]*.

When *L8-38* = 1, 2 [*Carrier Frequency Reduction = Enabled*], the drive applies *L8-40* as the time for the carrier frequency to return to its configured value after it is decreased.

### ■ L8-41: High Current Alarm Selection

| No. (Hex.)   | Name                         | Description  | Default (Range) |
|--------------|------------------------------|--|-----------------|
| L8-41 (04F2) | High Current Alarm Selection | <b>V/f</b> <b>CL-V/f</b> <b>OLV</b> <b>CLV</b> <b>AOLV</b> <b>OLV/PM</b> <b>AOLV/PM</b> <b>CLV/PM</b> <b>EZOLV</b><br>Sets the function to cause an <i>HCA [Current Alarm]</i> when the output current is more than 150% of the drive rated current. | 0 (0, 1)        |

#### 0 : Disabled

The drive will not detect *HCA [Current Alarm]*.

#### 1 : Enabled

If the output current is more than 150% of the drive rated current, the drive will detect *HCA*.

The MFDO terminal set for an alarm [*H2-01 to H2-03 = 10*] activates.

### ■ L8-51: STPo I Detection Level

| No. (Hex.)          | Name                   | Description  | Default (Range)     |
|---------------------|------------------------|--|---------------------|
| L8-51 (0471) Expert | STPo I Detection Level | <b>V/f</b> <b>CL-V/f</b> <b>OLV</b> <b>CLV</b> <b>AOLV</b> <b>OLV/PM</b> <b>AOLV/PM</b> <b>CLV/PM</b> <b>EZOLV</b><br>Sets the <i>STPo [Desynchronization Error]</i> detection level as a percentage of the motor rated current. | 0.0% (0.0 - 300.0%) |

#### Note:

The detection level is automatically calculated when *L8-51* = 0.

### ■ L8-52: STPo Integration Level

| No. (Hex.)          | Name                   | Description   | Default (Range) |
|---------------------|------------------------|---|-----------------|
| L8-52 (0472) Expert | STPo Integration Level | <b>V/f</b> <b>CL-V/f</b> <b>OLV</b> <b>CLV</b> <b>AOLV</b> <b>OLV/PM</b> <b>AOLV/PM</b> <b>CLV/PM</b> <b>EZOLV</b><br>Sets the detection level for <i>STPo [Motor Step-Out Detected]</i> related to the ACR integral value. | 1.0 (0.1 - 2.0) |

## 2.9 L: Protection Functions

### ■ L8-53: STPo Integration Time

| No. (Hex.)                | Name                  | Description  | Default (Range)         |
|---------------------------|-----------------------|--|-------------------------|
| L8-53<br>(0473)<br>Expert | STPo Integration Time | <div style="display: flex; justify-content: space-between; font-size: 0.8em;"> <span>V/f</span> <span>CL-V/f</span> <span>OLV</span> <span>CLV</span> <span>AOLV</span> <span style="background-color: #cccccc;">OLV/PM</span> <span>AOLV/PM</span> <span>CLV/PM</span> <span>EZOLV</span> </div> <p>Sets the length of time until the drive detects <i>STPo</i> after exceeding the value of L8-51 [<i>STPo I Detection Level</i>].</p> | 1.0 s<br>(1.0 - 10.0 s) |

### ■ L8-54: STPo Id Diff Detection

| No. (Hex.)                | Name                   | Description   | Default (Range) |
|---------------------------|------------------------|---|-----------------|
| L8-54<br>(0474)<br>Expert | STPo Id Diff Detection | <div style="display: flex; justify-content: space-between; font-size: 0.8em;"> <span>V/f</span> <span>CL-V/f</span> <span>OLV</span> <span>CLV</span> <span>AOLV</span> <span style="background-color: #cccccc;">OLV/PM</span> <span>AOLV/PM</span> <span>CLV/PM</span> <span>EZOLV</span> </div> <p>Sets the Id deviation detection function for <i>STPo</i> [<i>Motor Step-Out Detected</i>].</p> | 1<br>(0, 1)     |

**0 : Disabled**

**1 : Enabled**

### ■ L8-55: Internal DB TransistorProtection

| No. (Hex.)      | Name                             | Description  | Default (Range) |
|-----------------|----------------------------------|--|-----------------|
| L8-55<br>(045F) | Internal DB TransistorProtection | <div style="display: flex; justify-content: space-between; font-size: 0.8em;"> <span>V/f</span> <span>CL-V/f</span> <span>OLV</span> <span>CLV</span> <span>AOLV</span> <span style="background-color: #cccccc;">OLV/PM</span> <span>AOLV/PM</span> <span>CLV/PM</span> <span>EZOLV</span> </div> <p>Sets the protection function for the internal braking transistor.</p> | 1<br>(0, 1)     |

**0 : Disable**

Disables braking transistor protection.

Use this setting, if enabling the braking transistor can cause an *rF* [*Braking Resistor Fault*] in these conditions:

- With a regenerative converter, for example D1000.
- With a regenerative unit, for example R1000.
- When connecting braking resistor options to the drive, for example CDBR units.
- Without an internal braking transistor.

**1 : Protection Enabled**

Prevents damage to the internal braking transistor when using a braking transistor or optional braking resistors.

These models have a built-in braking transistor:

- 2004 to 2138
- 4002 to 4168

### ■ L8-56: Stall P @ Accel Activation Time

| No. (Hex.)                | Name                            | Description   | Default (Range)            |
|---------------------------|---------------------------------|---|----------------------------|
| L8-56<br>(047D)<br>Expert | Stall P @ Accel Activation Time | <div style="display: flex; justify-content: space-between; font-size: 0.8em;"> <span>V/f</span> <span>CL-V/f</span> <span>OLV</span> <span>CLV</span> <span>AOLV</span> <span style="background-color: #cccccc;">OLV/PM</span> <span>AOLV/PM</span> <span>CLV/PM</span> <span>EZOLV</span> </div> <p>Sets the length time that the acceleration stall prevention function can continue to operate before the drive detects an <i>STPo</i> [<i>Desynchronization Error</i>].</p> | 5000 ms<br>(100 - 5000 ms) |

**Note:**

If this value is too small, it can cause incorrect detection of *STPo*. If this value is too large, the drive will not detect *STPo*.

### ■ L8-57: Stall Prevention Retry Counts

| No. (Hex.)                | Name                          | Description   | Default (Range)      |
|---------------------------|-------------------------------|---|----------------------|
| L8-57<br>(047E)<br>Expert | Stall Prevention Retry Counts | <div style="display: flex; justify-content: space-between; font-size: 0.8em;"> <span>V/f</span> <span>CL-V/f</span> <span>OLV</span> <span>CLV</span> <span>AOLV</span> <span style="background-color: #cccccc;">OLV/PM</span> <span>AOLV/PM</span> <span>CLV/PM</span> <span>EZOLV</span> </div> <p>Sets the number of times the acceleration stall prevention function can operate until speeds match before the drive detects an <i>STPo</i> [<i>Desynchronization Error</i>].</p> | 10<br>(1 - 10 times) |

**Note:**

If this value is too small, it can cause incorrect detection of *STPo*. If this value is too large, the drive will not detect *STPo*.

### ■ L8-90: STPo Detection Level (Low Speed)

| No. (Hex.)                | Name                             | Description   | Default (Range)                         |
|---------------------------|----------------------------------|---|---|
| L8-90<br>(0175)<br>Expert | STPo Detection Level (Low Speed) | <div style="display: flex; justify-content: space-between; align-items: center;"> <span>V/f</span> <span>CL-V/f</span> <span>OLV</span> <span>CLV</span> <span>AOLV</span> <span style="background-color: #cccccc;">OLV/PM</span> <span style="background-color: #cccccc;">AOLV/PM</span> <span style="background-color: #cccccc;">CLV/PM</span> <span style="background-color: #cccccc;">EZOLV</span> </div> <p>Sets the detection level that the control fault must be equal to or more than to cause an <i>STPo</i> [Desynchronization Error].</p> | Determined by A1-02<br>(0 - 5000 times) |

This function detects when PM motors are not synchronized.

The drive cannot detect when motors are not synchronized because the frequency reference is low during start up and the motor is locked. If fault detection is necessary in these conditions, set the control fault detection level to enable detection of desynchronization because of motor locking. Increase the setting in 5-unit increments.

### ■ L8-93: Low Speed Pull-out DetectionTime

| No. (Hex.)                | Name                             | Description  | Default (Range)         |
|---------------------------|----------------------------------|--|-------------------------|
| L8-93<br>(073C)<br>Expert | Low Speed Pull-out DetectionTime | <div style="display: flex; justify-content: space-between; align-items: center;"> <span>V/f</span> <span>CL-V/f</span> <span>OLV</span> <span>CLV</span> <span>AOLV</span> <span style="background-color: #cccccc;">OLV/PM</span> <span style="background-color: #cccccc;">AOLV/PM</span> <span style="background-color: #cccccc;">CLV/PM</span> <span style="background-color: #cccccc;">EZOLV</span> </div> <p>Sets the length of time the drive will wait to start baseblock after detecting <i>LSo</i> [Low Speed Motor Step-Out].</p> | 1.0 s<br>(0.0 - 10.0 s) |

Set this parameter to 0.0 to disable the function.

### ■ L8-94: Low Speed Pull-out Detect Level

| No. (Hex.)                | Name                            | Description   | Default (Range) |
|---------------------------|---------------------------------|---|-----------------|
| L8-94<br>(073D)<br>Expert | Low Speed Pull-out Detect Level | <div style="display: flex; justify-content: space-between; align-items: center;"> <span>V/f</span> <span>CL-V/f</span> <span>OLV</span> <span>CLV</span> <span>AOLV</span> <span style="background-color: #cccccc;">OLV/PM</span> <span style="background-color: #cccccc;">AOLV/PM</span> <span style="background-color: #cccccc;">CLV/PM</span> <span style="background-color: #cccccc;">EZOLV</span> </div> <p>Sets the detection level for <i>LSo</i> [Low Speed Motor Step-Out] as a percentage of <i>E1-04</i> [Maximum Output Frequency].</p> | 3%<br>(0 - 10%) |

### ■ L8-95: Low Speed Pull-out Amount

| No. (Hex.)                | Name                      | Description  | Default (Range)      |
|---------------------------|---------------------------|--|----------------------|
| L8-95<br>(077F)<br>Expert | Low Speed Pull-out Amount | <div style="display: flex; justify-content: space-between; align-items: center;"> <span>V/f</span> <span>CL-V/f</span> <span>OLV</span> <span>CLV</span> <span>AOLV</span> <span style="background-color: #cccccc;">OLV/PM</span> <span style="background-color: #cccccc;">AOLV/PM</span> <span style="background-color: #cccccc;">CLV/PM</span> <span style="background-color: #cccccc;">EZOLV</span> </div> <p>Sets the average count of <i>LSo</i> [Low Speed Motor Step-Out] detections.</p> | 10<br>(1 - 50 times) |

## ◆ L9: Drive Protection 2

*L9* parameters are used to configure the protection function used to detect cooling fan faults.

### ■ L9-16: FAn1 Detect Time

| No. (Hex.)                | Name             | Description   | Default (Range)         |
|---------------------------|------------------|---|-------------------------|
| L9-16<br>(11DC)<br>Expert | FAn1 Detect Time | <div style="display: flex; justify-content: space-between; align-items: center;"> <span>V/f</span> <span>CL-V/f</span> <span>OLV</span> <span>CLV</span> <span>AOLV</span> <span style="background-color: #cccccc;">OLV/PM</span> <span style="background-color: #cccccc;">AOLV/PM</span> <span style="background-color: #cccccc;">CLV/PM</span> <span style="background-color: #cccccc;">EZOLV</span> </div> <p>Sets the detection time for <i>FAn1</i> [Drive Cooling Fan Fault]. Yaskawa recommends that you do not change this parameter value.</p> | 4.0 s<br>(0.0 - 30.0 s) |

## 2.10 n: Special Adjustment

*n* parameters set these functions:

- Function to prevent hunting
- High-slip braking
- Motor line-to-line resistance online tuning
- Fine-tune the parameters that adjust motor control

### ◆ n1: Hunting Prevention

The Hunting Prevention function will not let low inertia or operation with a light load cause hunting. Hunting frequently occurs when you have a high carrier frequency and an output frequency less than 30 Hz.

#### ■ n1-01: Hunting Prevention Selection

| No. (Hex.)      | Name                         | Description   | Default (Range)                 |
|-----------------|------------------------------|---|---------------------------------|
| n1-01<br>(0580) | Hunting Prevention Selection | <input checked="" type="checkbox"/> V/f <input checked="" type="checkbox"/> CL-V/f <input type="checkbox"/> OLV <input type="checkbox"/> CLV <input type="checkbox"/> AOLV <input type="checkbox"/> OLV/PM <input type="checkbox"/> AOLV/PM <input type="checkbox"/> CLV/PM <input type="checkbox"/> EZOLV<br>Sets the function to prevent hunting. | Determined by o2-04<br>(0 to 2) |

When drive response is more important than the decrease of motor vibration, disable this function.

If hunting occurs, or if you use a high carrier frequency or SwingPWM, set this parameter to 2 for better hunting prevention.

**0 : Disabled**

**1 : Enabled (Normal)**

**2 : Enabled (High Carrier Frequency)**

#### ■ n1-02: Hunting Prevention Gain Setting

| No. (Hex.)                | Name                            | Description  | Default (Range)       |
|---------------------------|---------------------------------|--|-----------------------|
| n1-02<br>(0581)<br>Expert | Hunting Prevention Gain Setting | <input checked="" type="checkbox"/> V/f <input checked="" type="checkbox"/> CL-V/f <input type="checkbox"/> OLV <input type="checkbox"/> CLV <input type="checkbox"/> AOLV <input type="checkbox"/> OLV/PM <input type="checkbox"/> AOLV/PM <input type="checkbox"/> CLV/PM <input type="checkbox"/> EZOLV<br>Sets the performance of the hunting prevention function. Usually it is not necessary to change this parameter. | 1.00<br>(0.00 - 2.50) |

Adjust this parameter in these conditions:

- When  $n1-01 = 1, 2$  [*Hunting Prevention Selection = Enabled (Normal), Enabled (High Carrier Frequency)*]: If oscillation occurs when you operate a motor with a light load, increase the setting value in 0.1-unit increments.
- When  $n1-01 = 1, 2$ , if the motor stalls: Decrease the setting value in 0.1-unit increments.

#### ■ n1-03: Hunting Prevention Time Constant

| No. (Hex.)                | Name                             | Description  | Default (Range)                     |
|---------------------------|----------------------------------|--|-------------------------------------|
| n1-03<br>(0582)<br>Expert | Hunting Prevention Time Constant | <input checked="" type="checkbox"/> V/f <input checked="" type="checkbox"/> CL-V/f <input type="checkbox"/> OLV <input type="checkbox"/> CLV <input type="checkbox"/> AOLV <input type="checkbox"/> OLV/PM <input type="checkbox"/> AOLV/PM <input type="checkbox"/> CLV/PM <input type="checkbox"/> EZOLV<br>Sets the primary delay time constant of the hunting prevention function. Usually it is not necessary to change this parameter. | Determined by o2-04<br>(0 - 500 ms) |

Adjust this parameter in these conditions:

- Load inertia is large: Increase the setting value. If the setting value is too high, response will be slower. Also, there will be oscillation when the frequency is low.
- Oscillation occurs at low frequencies: Decrease the setting value.



### ■ n1-05: Hunting Prevent Gain in Reverse

| No. (Hex.)                | Name                            | Description  | Default (Range)       |
|---------------------------|---------------------------------|--|-----------------------|
| n1-05<br>(0530)<br>Expert | Hunting Prevent Gain in Reverse | <b>V/f</b> <b>CL-V/f</b> <b>OLV</b> <b>CLV</b> <b>AOLV</b> <b>OLV/PM</b> <b>AOLV/PM</b> <b>CLV/PM</b> <b>EZOLV</b><br>Sets the performance of the hunting prevention function. This parameter adjusts Reverse run. Usually it is not necessary to change this parameter. | 0.00<br>(0.00 - 2.50) |

**Note:**

When you set this parameter to 0, the value set in *n1-02* [*Hunting Prevention Gain Setting*] is effective when the motor rotates in reverse.

Adjust this parameter in these conditions:

- When *n1-01* = 1, 2 [*Hunting Prevention Selection = Enabled (Normal), Enabled (High Carrier Frequency)*]: If oscillation occurs when you operate a motor with a light load, increase the setting value in 0.1-unit increments.
- When *n1-01* = 1, 2, if the motor stalls: Decrease the setting value in 0.1-unit increments.

### ■ n1-08: Current Detection Method

| No. (Hex.)                | Name                     | Description   | Default (Range) |
|---------------------------|--------------------------|---|-----------------|
| n1-08<br>(1105)<br>Expert | Current Detection Method | <b>V/f</b> <b>CL-V/f</b> <b>OLV</b> <b>CLV</b> <b>AOLV</b> <b>OLV/PM</b> <b>AOLV/PM</b> <b>CLV/PM</b> <b>EZOLV</b><br>Sets how the drive decreases the motor vibration that is caused by leakage current. Usually it is not necessary to change this parameter. | 0<br>(0, 1)     |

**0 : 2-Phases**

**1 : 3-Phases**

**Note:**

Set this parameter to 1 to suppress motor vibrations caused by leakage current when the wiring distance is long.

### ■ n1-13: DC Bus Stabilization Control

| No. (Hex.)                | Name                         | Description   | Default (Range) |
|---------------------------|------------------------------|---|-----------------|
| n1-13<br>(1B59)<br>Expert | DC Bus Stabilization Control | <b>V/f</b> <b>CL-V/f</b> <b>OLV</b> <b>CLV</b> <b>AOLV</b> <b>OLV/PM</b> <b>AOLV/PM</b> <b>CLV/PM</b> <b>EZOLV</b><br>Sets the oscillation suppression function for the DC bus voltage. | 0<br>(0, 1)     |

**0 : Disabled**

**1 : Enabled**

**Note:**

If the DC bus voltage does not become stable with light loads and the drive detects *ov* [*Overvoltage*], set this parameter to 1.

### ■ n1-14: DC Bus Stabilization Time

| No. (Hex.)                | Name                      | Description   | Default (Range)               |
|---------------------------|---------------------------|---|-------------------------------|
| n1-14<br>(1B5A)<br>Expert | DC Bus Stabilization Time | <b>V/f</b> <b>CL-V/f</b> <b>OLV</b> <b>CLV</b> <b>AOLV</b> <b>OLV/PM</b> <b>AOLV/PM</b> <b>CLV/PM</b> <b>EZOLV</b><br>Adjusts the responsiveness of the oscillation suppression function for the DC bus voltage. Set <i>n1-13</i> = 1 [ <i>DC Bus Stabilization Control = Enabled</i> ] to enable this parameter. | 100.0 ms<br>(50.0 - 500.0 ms) |

**Note:**

Adjust this parameter in 100 ms increments.

### ■ n1-15: PWM Voltage Offset Calibration

| No. (Hex.)                | Name                           | Description  | Default (Range)                |
|---------------------------|--------------------------------|--|--------------------------------|
| n1-15<br>(0BF8)<br>Expert | PWM Voltage Offset Calibration | <b>V/f</b> <b>CL-V/f</b> <b>OLV</b> <b>CLV</b> <b>AOLV</b> <b>OLV/PM</b> <b>AOLV/PM</b> <b>CLV/PM</b> <b>EZOLV</b><br>Sets the calibration method that the drive uses to decrease torque/current ripple. | Determined by A1-02<br>(0 - 2) |

## 2.10 n: Special Adjustment

This calibration function lets the drive suppress the torque ripple of a motor. Usually it is not necessary to change this setting.

**0 : No**

**1 : One Time Calibrate at Next Start**

**2 : Calibrate Every Time at Start**

### ■ n1-16: Hunting Prevention High Fc Gain

| No. (Hex.)                | Name                            | Description  | Default (Range)                      |
|---------------------------|---------------------------------|--|--------------------------------------|
| n1-16<br>(0BFB)<br>Expert | Hunting Prevention High Fc Gain | <input checked="" type="checkbox"/> V/f <input type="checkbox"/> CL-V/f <input type="checkbox"/> OLV <input type="checkbox"/> CLV <input type="checkbox"/> AOLV <input type="checkbox"/> OLV/PM <input type="checkbox"/> AOLV/PM <input type="checkbox"/> CLV/PM <input type="checkbox"/> EZOLV<br>Sets the gain for the hunting prevention function. This parameter functions best with a high carrier frequency. Usually it is not necessary to change this parameter. | Determined by o2-04<br>(0.00 - 2.50) |

Set  $n1-01 = 2$  [*Hunting Prevention Selection = Enabled (High Carrier Frequency)*] to enable this function.

If the motor oscillates, set  $n1-01 = 2$ . If that does not have an effect, increase this parameter in 0.2-unit increments.

### ■ n1-17: Hunting Prevent High Fc Filter

| No. (Hex.)                | Name                           | Description  | Default (Range)         |
|---------------------------|--------------------------------|--|-------------------------|
| n1-17<br>(0BFC)<br>Expert | Hunting Prevent High Fc Filter | <input checked="" type="checkbox"/> V/f <input type="checkbox"/> CL-V/f <input type="checkbox"/> OLV <input type="checkbox"/> CLV <input type="checkbox"/> AOLV <input type="checkbox"/> OLV/PM <input type="checkbox"/> AOLV/PM <input type="checkbox"/> CLV/PM <input type="checkbox"/> EZOLV<br>Sets the responsiveness of the hunting prevention function. Usually it is not necessary to change this parameter. | 500 ms<br>(0 - 1000 ms) |

When  $n1-01 = 2$  [*Hunting Prevention Selection = Enabled (High Carrier Frequency)*], if the motor stalls when the load changes, increase the value set in this parameter in 100 ms increments.

If you set  $n1-01 = 2$  and you cannot suppress hunting, increase the value set in this parameter in 100 ms increments.

### ■ n1-20: PWM Voltage Offset Calibration Time

| No. (Hex.)                | Name                                | Description  | Default (Range)        |
|---------------------------|-------------------------------------|--|------------------------|
| n1-20<br>(1588)<br>Expert | PWM Voltage Offset Calibration Time | <input checked="" type="checkbox"/> V/f <input type="checkbox"/> CL-V/f <input type="checkbox"/> OLV <input type="checkbox"/> CLV <input type="checkbox"/> AOLV <input type="checkbox"/> OLV/PM <input type="checkbox"/> AOLV/PM <input type="checkbox"/> CLV/PM <input type="checkbox"/> EZOLV<br>Sets the calibration time at start. Usually it is not necessary to change this parameter. | 50 ms<br>(10 - 500 ms) |

## ◆ n2: Auto Freq Regulator (AFR)

The speed feedback detection reduction function (or AFR: Automatic Frequency Regulator) helps the speed become stable when you suddenly apply or remove a load.

**Note:**

Before you change *n2-xx parameters*, do one of these procedures:

- Set the motor parameters and V/f pattern correctly.
- Do Rotational Auto-Tuning.

### ■ n2-01: Automatic Freq Regulator Gain

| No. (Hex.)      | Name                          | Description  | Default (Range)        |
|-----------------|-------------------------------|--|------------------------|
| n2-01<br>(0584) | Automatic Freq Regulator Gain | <input type="checkbox"/> V/f <input type="checkbox"/> CL-V/f <input checked="" type="checkbox"/> OLV <input type="checkbox"/> CLV <input type="checkbox"/> AOLV <input type="checkbox"/> OLV/PM <input type="checkbox"/> AOLV/PM <input type="checkbox"/> CLV/PM <input type="checkbox"/> EZOLV<br>Sets the gain of the AFR function as a magnification value. Usually it is not necessary to change this setting. | 1.00<br>(0.00 - 10.00) |

Adjust this parameter in these conditions:

- If hunting or oscillation occurs with light loads, increase the setting value in 0.05-unit increments and examine the response.
- When torque is not sufficient with heavy loads or to make the torque or speed response better, decrease the setting value in 0.05-unit increments and examine the response.

### ■ n2-02: Automatic Freq Regulator Time 1

| No. (Hex.)   | Name                            | Description  | Default (Range)     |
|--------------|---------------------------------|--|---------------------|
| n2-02 (0585) | Automatic Freq Regulator Time 1 | <div style="display: flex; justify-content: space-between; font-size: small;"> <span>V/f</span> <span>CL-V/f</span> <span style="background-color: #ccc;">OLV</span> <span>CLV</span> <span>AOLV</span> <span>OLV/PM</span> <span>AOLV/PM</span> <span>CLV/PM</span> <span>EZOLV</span> </div> Sets the time constant that sets the rate of change for the AFR function. Usually it is not necessary to change this setting. | 50 ms (0 - 2000 ms) |

Adjust this parameter in these conditions:

- If there is hunting or oscillation with a light load, increase the setting value in 50 ms increments and examine the response. If the load inertia is large, increase the setting value in 50 ms increments and examine the response.
- If torque is not sufficient with a heavy load or if you must increase torque or speed responsiveness, decrease the setting value in 10 ms increments and examine the response.

**Note:**

- Set  $n2-02 \leq n2-03$  [Automatic Freq Regulator Time 2]. If  $n2-02 > n2-03$ , the drive will detect *oPE08* [Parameter Selection Error].
- When you change the value in *n2-02*, also change the value in *C4-02* [Torque Compensation Delay Time] by the same ratio.

### ■ n2-03: Automatic Freq Regulator Time 2

| No. (Hex.)   | Name                            | Description  | Default (Range)      |
|--------------|---------------------------------|--|----------------------|
| n2-03 (0586) | Automatic Freq Regulator Time 2 | <div style="display: flex; justify-content: space-between; font-size: small;"> <span>V/f</span> <span>CL-V/f</span> <span style="background-color: #ccc;">OLV</span> <span>CLV</span> <span>AOLV</span> <span>OLV/PM</span> <span>AOLV/PM</span> <span>CLV/PM</span> <span>EZOLV</span> </div> Sets the time constant that sets the speed difference of the AFR function. Use this parameter for speed searches or regeneration. Usually it is not necessary to change this setting. | 750 ms (0 - 2000 ms) |

Adjust this parameter in these conditions:

- If the drive detects *ov* [Overvoltage] when acceleration stops under high-inertia loads, increase the setting value in 50 ms increments. If the drive detects *ov* when the load changes suddenly, increase the setting value in 50 ms increments.
- To increase the responsiveness of torque and speed, decrease the setting value in 10 ms increments and examine the response.

**Note:**

- Set  $n2-02 \leq n2-03$  [Automatic Freq Regulator Time 2]. If  $n2-02 > n2-03$ , the drive will detect *oPE08* [Parameter Selection Error].
- When you change the value in *n2-03*, also change the value in *C4-06* [Motor 2 Torque Comp Delay Time] by the same ratio.

## ◆ n3: High Slip Braking (HSB) and Overexcitation Braking

*n3* parameters configure High Slip Braking and Overexcitation Deceleration.

### ■ High Slip Braking

High slip braking quickly decelerates motors without braking resistors.

This lets you stop a motor more quickly than with the ramp to stop processes. This function is best for applications that do not frequently stop the motor, for example the fast stop function for high-inertia loads. Braking starts when the MFDI for *High Slip Braking (HSB) Activate* [*H1-xx = 68*] activates.

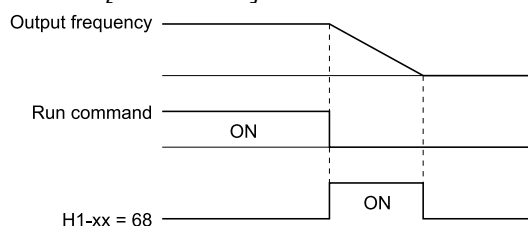


Figure 2.143 High Slip Braking Time Chart

An induction motor is necessary to use high slip braking. Set *A1-02* [Control Method Selection] to one of these values to enable high slip braking:

- 0 [V/f Control]
- 1 [V/f Control with Encoder]

### Principles of Operation

HSB increases motor slip by significantly decreasing the frequency supplied to the motor at the same time that deceleration starts. A large quantity of current flows through the motor to increase the motor loss, and the motor decelerates while the motor windings consume the regenerative energy.

The drive keeps the motor current at a constant level during deceleration to prevent overvoltage and do automatic braking and it also keeps a slip level that causes the maximum quantity of deceleration torque.

### High Slip Braking Precautions

- Do not use the high slip braking function in these applications:
  - Frequent deceleration
  - Deceleration time differences
  - Continuous regenerative loads
  - It is necessary to accelerate again during deceleration
- Motor loss increases during high slip braking. Use this function when the duty time factor is 5% ED or less and the braking time is 90 seconds or less. The load inertia and motor characteristics have an effect on the braking time.
- The drive ignores the configured deceleration time during high slip braking. To stop motors in the configured deceleration time, set  $L3-04 = 4$  [*Stall Prevention during Decel = Overexcitation/High Flux*].
- You cannot use high slip braking to decelerate deceleration at user-defined speeds. To decelerate at user-defined speeds, use the overexcitation deceleration function.
- You cannot accelerate the motor again during high slip braking until you fully stop the motor and input the Run command again.
- You cannot use high slip braking and the KEB Ride-Thru function at the same time. If you enable those two functions, the drive will detect *oPE03* [*Multi-Function Input Setting Err*].

### ■ Overexcitation Deceleration

Overexcitation deceleration quickly decelerates motors without braking resistors. This lets you stop a motor more quickly than with the ramp to stop processes.

Overexcitation deceleration increases excitation current during deceleration to cause a large quantity of braking torque through motor overexcitation. You can set the deceleration speed to adjust the deceleration time for overexcitation deceleration.

Overexcitation deceleration lets you accelerate the motor again during deceleration.

Enter the Run command during overexcitation deceleration to cancel overexcitation deceleration and accelerate the drive to the specified speed.

To enable this function, set  $L3-04 = 4, 5$  [*Stall Prevention during Decel = Overexcitation/High Flux, Overexcitation/High Flux 2*].

When  $L3-04 = 4$ , the motor will decelerate for the deceleration time set in  $C1-02$ ,  $C1-04$ ,  $C1-06$ , or  $C1-08$ . If the drive detects *ov* [*Overvoltage*], increase the deceleration time.

When  $L3-04 = 5$ , the drive uses the value in  $C1-02$ ,  $C1-04$ ,  $C1-06$ , or  $C1-08$  to decelerate and it adjusts the deceleration rate to keep the DC bus voltage at the level set in  $L3-17$  [*DC Bus Regulation Level*]. The load inertia and motor characteristics have an effect on the braking time.

### Notes on Overexcitation Deceleration

- Do not use Overexcitation Deceleration with a braking resistor.
- Do not use Overexcitation Deceleration for these applications. Connect a braking resistor to the drive as an alternative to Overexcitation Deceleration.
  - Frequent sudden decelerations
  - Continuous regenerative loads
  - Low inertia machines
  - Machines that have no tolerance for torque ripples
- Motor loss increases during overexcitation deceleration. Use this function when the duty time factor is 5% ED or less and the braking time is 90 seconds or less. The load inertia and motor characteristics have an effect on the

braking time. You can use overexcitation deceleration in OLV control and CLV control, but those control methods decrease the precision of torque control and braking efficiency. Use V/f control for the best results.

- The drive disables these functions during braking with Overexcitation Deceleration 2:
  - Hunting Prevention Function (V/f Control)
  - Torque Limit Speed Control (OLV Control)

### ■ n3-01: HSB Deceleration Frequency Width

| No. (Hex.)                | Name                             | Description   | Default (Range) |
|---------------------------|----------------------------------|---|-----------------|
| n3-01<br>(0588)<br>Expert | HSB Deceleration Frequency Width | <div style="display: flex; justify-content: space-between; font-size: 0.8em; margin-bottom: 5px;"> <span>V/f</span> <span>CL-V/f</span> <span>OLV</span> <span>CLV</span> <span>AOLV</span> <span>OLV/PM</span> <span>AOLV/PM</span> <span>CLV/PM</span> <span>EZOLV</span> </div> Sets the amount by which the output frequency is to be lowered during high-slip braking, as a percentage of <i>E1-04 [Maximum Output Frequency]</i> , which represents the 100% value. | 5%<br>(1 - 20%) |

When you must detect *ov [DC Bus Overvoltage]* during high-slip braking, set this parameter to a large value.

### ■ n3-02: HSB Current Limit Level

| No. (Hex.)                | Name                    | Description   | Default (Range)                          |
|---------------------------|-------------------------|---|--|
| n3-02<br>(0589)<br>Expert | HSB Current Limit Level | <div style="display: flex; justify-content: space-between; font-size: 0.8em; margin-bottom: 5px;"> <span>V/f</span> <span>CL-V/f</span> <span>OLV</span> <span>CLV</span> <span>AOLV</span> <span>OLV/PM</span> <span>AOLV/PM</span> <span>CLV/PM</span> <span>EZOLV</span> </div> Sets the maximum current output during high-slip braking as a percentage of <i>E2-01 [Motor Rated Current (FLA)]</i> . Also set the current suppression to prevent exceeding drive overload tolerance. | Determined by C6-01, L8-38<br>(0 - 150%) |

**Note:**

The upper limit of the setting range changes when the setting for *C6-01 [Normal / Heavy Duty Selection]* changes.

- 150% when *C6-01 = 0 [Heavy Duty Rating 1 (HD1) for Constant Torque Applications]*.
- 110% when *C6-01 = 1 [Normal Duty Rating 1 (ND1) for Variable Torque Applications]*.

When you decrease the setting value for current suppression, it will make the deceleration time longer.

- When you must detect *ov [DC Bus Overvoltage]* during high-slip braking, set this parameter to a low value.
- If the motor current increases during high-slip braking, decrease the setting value to prevent burn damage in the motor.
- The overload tolerance for the drive is 150% for Heavy Duty Rating (HD) and 110% for Normal Duty Rating (ND).

### ■ n3-03: HSB Dwell Time at Stop

| No. (Hex.)                | Name                   | Description  | Default (Range)         |
|---------------------------|------------------------|--|-------------------------|
| n3-03<br>(058A)<br>Expert | HSB Dwell Time at Stop | <div style="display: flex; justify-content: space-between; font-size: 0.8em; margin-bottom: 5px;"> <span>V/f</span> <span>CL-V/f</span> <span>OLV</span> <span>CLV</span> <span>AOLV</span> <span>OLV/PM</span> <span>AOLV/PM</span> <span>CLV/PM</span> <span>EZOLV</span> </div> Sets the dwell time, a length of time when high-slip braking is ending and during which the motor speed decreases and runs at a stable speed. For a set length of time, the drive will hold the actual output frequency at the minimum output frequency set in <i>E1-09</i> . | 1.0 s<br>(0.0 - 10.0 s) |

If there is too much inertia or when the motor is coasting to a stop after high-slip braking is complete, increase the setting value. If the setting value is too low, machine inertia can cause the motor to rotate after high-slip braking is complete.

### ■ n3-04: HSB Overload Time

| No. (Hex.)                | Name              | Description  | Default (Range)       |
|---------------------------|-------------------|--|-----------------------|
| n3-04<br>(058B)<br>Expert | HSB Overload Time | <div style="display: flex; justify-content: space-between; font-size: 0.8em; margin-bottom: 5px;"> <span>V/f</span> <span>CL-V/f</span> <span>OLV</span> <span>CLV</span> <span>AOLV</span> <span>OLV/PM</span> <span>AOLV/PM</span> <span>CLV/PM</span> <span>EZOLV</span> </div> Sets the time used to detect <i>oL7 [High Slip Braking Overload]</i> , which occurs when the output frequency does not change during high-slip braking. Usually it is not necessary to change this parameter. | 40 s<br>(30 - 1200 s) |

If a force on the load side is rotating the motor or if there is too much load inertia connected to the motor, the drive will detect *oL7*.

The current flowing to the motor from the load can overheat the motor and cause burn damage to the motor. Set this parameter to prevent burn damage to the motor.

## 2.10 n: Special Adjustment

### ■ n3-13: OverexcitationBraking (OEB) Gain

| No. (Hex.)   | Name                             | Description  | Default (Range)       |
|--------------|----------------------------------|--|-----------------------|
| n3-13 (0531) | OverexcitationBraking (OEB) Gain | <div style="display: flex; justify-content: space-between; font-size: 0.8em; margin-bottom: 5px;"> <span>V/f</span> <span>CL-V/f</span> <span>OLV</span> <span>CLV</span> <span>AOLV</span> <span>OLV/PM</span> <span>AOLV/PM</span> <span>CLV/PM</span> <span>EZOLV</span> </div> Sets the gain value that the drive multiplies by the V/f pattern output value during overexcitation deceleration to calculate the overexcitation level. | 1.10<br>(1.00 - 1.40) |

The V/f pattern output value goes back to its usual level after the motor stops or accelerates again to the frequency reference speed.

The best value of this parameter changes when the flux saturation characteristics of the motor change.

- Gradually increase the value of *n3-13* to 1.25 or 1.30 to increase the braking power of Overexcitation Deceleration. If the gain is too much, the motor can have flux saturation and cause a large quantity of current to flow. This can increase the deceleration time.
- Decrease the setting value if flux saturation causes overcurrent. If you increase the setting value, the drive can detect *oC* [Overcurrent], *oL1* [Motor Overload], and *oL2* [Drive Overload]. Decrease the value of *n3-21* [HSB Current Suppression Level] to prevent *oC* and *oL*.
- Regular use of overexcitation deceleration or extended periods of overexcitation deceleration can increase internal motor temperatures. Decrease the setting value in these conditions.
- If *ov* [Overvoltage] occurs, increase the deceleration time.

### ■ n3-14: OEB High Frequency Injection

| No. (Hex.)             | Name                         | Description  | Default (Range) |
|------------------------|------------------------------|--|-----------------|
| n3-14 (0532)<br>Expert | OEB High Frequency Injection | <div style="display: flex; justify-content: space-between; font-size: 0.8em; margin-bottom: 5px;"> <span>V/f</span> <span>CL-V/f</span> <span>OLV</span> <span>CLV</span> <span>AOLV</span> <span>OLV/PM</span> <span>AOLV/PM</span> <span>CLV/PM</span> <span>EZOLV</span> </div> Sets the function that injects harmonic signals during overexcitation deceleration. | 0<br>(0, 1)     |

Enable this parameter to set a shorter deceleration time.

#### Note:

- If you frequently use overexcitation deceleration on a motor, the motor loss will increase the risk of burn damage.
- When you set this parameter to 1, the motor can make a loud excitation sound during overexcitation deceleration. If the excitation sound is unwanted, set this parameter to 0 to disable the function.

**0 : Disabled**

**1 : Enabled**

The drive injects harmonic signals at the time of overexcitation deceleration. You can decrease the deceleration time because motor loss increases.

### ■ n3-21: HSB Current Suppression Level

| No. (Hex.)   | Name                          | Description  | Default (Range)    |
|--------------|-------------------------------|--|--------------------|
| n3-21 (0579) | HSB Current Suppression Level | <div style="display: flex; justify-content: space-between; font-size: 0.8em; margin-bottom: 5px;"> <span>V/f</span> <span>CL-V/f</span> <span>OLV</span> <span>CLV</span> <span>AOLV</span> <span>OLV/PM</span> <span>AOLV/PM</span> <span>CLV/PM</span> <span>EZOLV</span> </div> Sets the upper limit of the current that is suppressed at the time of overexcitation deceleration as a percentage of the drive rated current. | 100%<br>(0 - 150%) |

If flux saturation during Overexcitation Deceleration makes the motor current become more than the value set in this parameter, the drive will automatically decrease the overexcitation gain. If *oC* [Overcurrent], *oL1* [Motor Overload], or *oL2* [Drive Overloaded] occur during overexcitation deceleration, decrease the setting value.

If repetitive or long overexcitation deceleration cause the motor to overheat, decrease the setting value.

### ■ n3-23: Overexcitation Braking Operation

| No. (Hex.)   | Name                             | Description   | Default (Range) |
|--------------|----------------------------------|---|-----------------|
| n3-23 (057B) | Overexcitation Braking Operation | <div style="display: flex; justify-content: space-between; font-size: 0.8em; margin-bottom: 5px;"> <span>V/f</span> <span>CL-V/f</span> <span>OLV</span> <span>CLV</span> <span>AOLV</span> <span>OLV/PM</span> <span>AOLV/PM</span> <span>CLV/PM</span> <span>EZOLV</span> </div> Sets the direction of motor rotation where the drive will enable overexcitation. | 0<br>(0 - 2)    |

**0 : Disabled**

**1 : Enabled Only when Rotating FWD****2 : Enabled Only when Rotating REV****Note:**

When  $n3-23 = 1, 2$ , the drive enables overexcitation only in the direction of motor rotation in which a regenerative load is applied. Increased motor loss can decrease *ov* [Overvoltage] faults.

**◆ n4: Adv Open Loop Vector Tune**

The following explains how to make special adjustments for *Advanced Open Loop Vector* [ $A1-02 = 4$ ].

- First, perform Rotational Auto-Tuning.
- Operation that fluctuates around zero speed cannot be carried out when there is a load. For applications of this sort, set  $A1-02 = 3$  [Open Loop Vector].
- The tolerance of regenerative torque at low speeds is diminished. If regenerative torque is required in the low speed range, set  $A1-02 = 3$ .
- This cannot be used for elevators or similar applications. There is a risk that the load could slip.

**■ n4-60: Motoring Low Speed Comp Gain**

| No. (Hex.)   | Name                         | Description  | Default (Range)           |
|--------------|------------------------------|--|---------------------------|
| n4-60 (1B80) | Motoring Low Speed Comp Gain | V/f CL-V/f OLV CLV <b>AOLV</b> OLV/PM AOLV/PM CLV/PM EZOLV<br>Sets a compensation gain to improve the control qualities for motoring loads in the low speed range. | 100.0%<br>(50.0 - 200.0%) |

**Note:**

- To increase the torque precision in the motoring direction when you operate at low speeds, do Stationary Auto-Tuning for Line-to-Line Resistance only, or increase the value of this parameter in 5% increments.
- If the output frequency changes when you operate at low speeds, do Stationary Auto-Tuning for Line-to-Line Resistance only. If it is not better, increase this parameter in 10% increments. The recommended setting is 50% to 100%.

**■ n4-61: Low Speed Comp Frequency Level**

| No. (Hex.)   | Name                           | Description  | Default (Range)              |
|--------------|--------------------------------|--|------------------------------|
| n4-61 (1B81) | Low Speed Comp Frequency Level | V/f CL-V/f OLV CLV <b>AOLV</b> OLV/PM AOLV/PM CLV/PM EZOLV<br>Sets a frequency at which the settings $n4-60$ [Motoring Low Speed Comp Gain] and $n4-62$ [Regen Low Speed Comp Gain] are enabled. When the output frequency $< n4-61$ , the drive adjusts the torque to agree with the settings for $n4-60$ and $n4-62$ . Usually it is not necessary to change this setting. | 6.00 Hz<br>(0.50 - 12.00 Hz) |

**■ n4-62: Regen Low Speed Comp Gain**

| No. (Hex.)   | Name                      | Description  | Default (Range)         |
|--------------|---------------------------|--|-------------------------|
| n4-62 (1B82) | Regen Low Speed Comp Gain | V/f CL-V/f OLV CLV <b>AOLV</b> OLV/PM AOLV/PM CLV/PM EZOLV<br>Sets a compensation gain to improve the control qualities for regenerative loads in the low speed range. | 100.0<br>(50.0 - 500.0) |

**Note:**

If you do not apply a regenerative load when you operate at low speeds, do stationary Auto-Tuning for Line-to-Line Resistance only. If this does not make it better, increase the setting value in 5% increments. The recommended setting is 100% to 150%. If you set this parameter too high, the drive will detect *CF* [Control Fault] at stop.

**■ n4-63: Speed EstimateResponse@High Freq**

| No. (Hex.)   | Name                             | Description   | Default (Range)       |
|--------------|----------------------------------|---|-----------------------|
| n4-63 (1B83) | Speed EstimateResponse@High Freq | V/f CL-V/f OLV CLV <b>AOLV</b> OLV/PM AOLV/PM CLV/PM EZOLV<br>Sets the responsiveness of the speed estimation in high speed ranges, where the output frequency is $\geq n4-67$ [Estimate Gain Switchover Freq]. | 60.0<br>(0.1 - 300.0) |

If better response of speed estimation is necessary, or if the motor oscillates, or if there is a large quantity of torque ripple, increase the setting value in 10.0 unit increments. If this does not make it better, decrease the setting value in 10.0 unit increments.

## 2.10 n: Special Adjustment

### Note:

Do rotational Auto-Tuning before you adjust *n4-63*, *n4-64* [*Speed Estimate Response@Low Freq*], *n4-65* [*Flux Estimate Response@High Freq*], and *n4-66* [*Flux Estimate Response @Low Freq*].

### ■ n4-64: Speed Estimate Response@Low Freq

| No. (Hex.)   | Name                             | Description  | Default (Range)       |
|--------------|----------------------------------|--|-----------------------|
| n4-64 (1B84) | Speed Estimate Response@Low Freq | <div style="display: flex; justify-content: space-between; font-size: 0.8em; margin-bottom: 5px;"> <span>V/f</span> <span>CL-V/f</span> <span>OLV</span> <span>CLV</span> <span style="background-color: #cccccc;">AOLV</span> <span>OLV/PM</span> <span>AOLV/PM</span> <span>CLV/PM</span> <span>EZOLV</span> </div> <p>Sets the responsiveness of the speed estimation in low speed ranges, where <math>0 \leq</math> the output frequency, which is <math>&lt; n4-67</math> [<i>Estimate Gain Switchover Freq</i>].</p> | 60.0<br>(0.1 - 300.0) |

If better response of speed estimation is necessary, or if the motor oscillates, or if there is a large quantity of torque ripple, increase the setting value in 10.0 unit increments.

### Note:

Do rotational Auto-Tuning before you adjust *n4-63* [*Speed EstimateResponse@High Freq*], *n4-64*, *n4-65* [*Flux Estimate Response@High Freq*], and *n4-66* [*Flux Estimate Response @Low Freq*].

### ■ n4-65: Flux Estimate Response@High Freq

| No. (Hex.)   | Name                             | Description  | Default (Range)       |
|--------------|----------------------------------|--|-----------------------|
| n4-65 (1B85) | Flux Estimate Response@High Freq | <div style="display: flex; justify-content: space-between; font-size: 0.8em; margin-bottom: 5px;"> <span>V/f</span> <span>CL-V/f</span> <span>OLV</span> <span style="background-color: #cccccc;">CLV</span> <span>AOLV</span> <span>OLV/PM</span> <span>AOLV/PM</span> <span>CLV/PM</span> <span>EZOLV</span> </div> <p>Sets the responsiveness of the magnetic flux estimation in high speed ranges, where the output frequency is <math>\geq n4-67</math> [<i>Estimate Gain Switchover Freq</i>]. Usually it is not necessary to change this setting.</p> | 1.00<br>(0.50 - 3.00) |

If the drive detects *oS* [*Overspeed*] in no-load conditions, or if the speed does not become stable in the high speed range, increase or decrease the setting value in 0.05 unit increments.

### ■ n4-66: Flux Estimate Response @Low Freq

| No. (Hex.)   | Name                             | Description  | Default (Range)       |
|--------------|----------------------------------|--|-----------------------|
| n4-66 (1B86) | Flux Estimate Response @Low Freq | <div style="display: flex; justify-content: space-between; font-size: 0.8em; margin-bottom: 5px;"> <span>V/f</span> <span>CL-V/f</span> <span>OLV</span> <span style="background-color: #cccccc;">CLV</span> <span>AOLV</span> <span>OLV/PM</span> <span>AOLV/PM</span> <span>CLV/PM</span> <span>EZOLV</span> </div> <p>Sets the responsiveness of the magnetic flux estimation in low speed ranges, where <math>0 \leq</math> the output frequency, which is <math>&lt; n4-67</math> [<i>Estimate Gain Switchover Freq</i>]. Usually it is not necessary to change this setting.</p> | 1.50<br>(0.50 - 3.00) |

If the drive detects *oS* [*Overspeed*] in no-load conditions, or if the speed does not become stable in the low speed range, increase or decrease the setting value in 0.05 unit increments.

### ■ n4-67: Estimate Gain Switchover Freq

| No. (Hex.)   | Name                          | Description  | Default (Range)                   |
|--------------|-------------------------------|--|-----------------------------------|
| n4-67 (1B87) | Estimate Gain Switchover Freq | <div style="display: flex; justify-content: space-between; font-size: 0.8em; margin-bottom: 5px;"> <span>V/f</span> <span>CL-V/f</span> <span>OLV</span> <span style="background-color: #cccccc;">CLV</span> <span>AOLV</span> <span>OLV/PM</span> <span>AOLV/PM</span> <span>CLV/PM</span> <span>EZOLV</span> </div> <p>Sets the switching frequency for estimation gain for these parameters:<br/> <i>n4-63</i> [<i>Speed EstimateResponse@High Freq</i>]<br/> <i>n4-64</i> [<i>Speed Estimate Response@Low Freq</i>]<br/> <i>n4-65</i> [<i>Flux Estimate Response@High Freq</i>]<br/> <i>n4-66</i> [<i>Flux Estimate Response @Low Freq</i>]<br/>                     Usually it is not necessary to change this setting.</p> | 6.00 Hz<br>(0.00 - E1-04 setting) |

If the output frequency  $\geq n4-67$ , the drive will select *n4-63* and *n4-65*. If the output frequency  $< n4-67$ , the drive will select *n4-64* and *n4-66*.

### ■ n4-68: Speed Estimation Filter Time

| No. (Hex.)   | Name                         | Description   | Default (Range)              |
|--------------|------------------------------|---|------------------------------|
| n4-68 (1B88) | Speed Estimation Filter Time | <div style="display: flex; justify-content: space-between; font-size: 0.8em; margin-bottom: 5px;"> <span>V/f</span> <span>CL-V/f</span> <span>OLV</span> <span>CLV</span> <span style="background-color: #cccccc;">AOLV</span> <span>OLV/PM</span> <span>AOLV/PM</span> <span>CLV/PM</span> <span>EZOLV</span> </div> <p>Sets the primary delay time constant for the speed estimation value. Usually it is not necessary to change this setting.</p> | 0.001 s<br>(0.001 - 0.010 s) |

If the motor speed oscillates in the high speed range, set the value to 0.010 s.



### ■ n4-69: Flux Control Response

| No. (Hex.)      | Name                  | Description  | Default (Range)        |
|-----------------|-----------------------|--|------------------------|
| n4-69<br>(1B89) | Flux Control Response | V/f CL-V/f OLV CLV <b>AOLV</b> OLV/PM AOLV/PM CLV/PM EZOLV<br>Unifies control of magnetic flux to make motor vibrations more stable. | 1.00<br>(0.00 - 60.00) |

If step-out occurs when the load changes, decrease the setting value in 1.00 increments.

**Note:**

If heavy loads decrease motor speed, increase the setting value in 1.00 increments. If it does not get better, increase *n4-74 [Limit of Flux Loop]* in 20% increments.

### ■ n4-70: Speed Command Comp @ Low Freq

| No. (Hex.)      | Name                          | Description   | Default (Range)             |
|-----------------|-------------------------------|---|-----------------------------|
| n4-70<br>(1B8A) | Speed Command Comp @ Low Freq | V/f CL-V/f OLV CLV <b>AOLV</b> OLV/PM AOLV/PM CLV/PM EZOLV<br>Sets the function to make the drive more stable when operating at low speeds. Usually it is not necessary to change this setting. | 1.00 Hz<br>(0.00 - 6.00 Hz) |

This function makes the control more stable when operating at low speeds. Increase the setting in 0.3 Hz increments at the time of low-speed references with no load.

**Note:**

If you increase this parameter to make the speed references for low speeds more stable, it can make the speed control less accurate.

### ■ n4-71: Flux Estimation Method

| No. (Hex.)                | Name                   | Description  | Default (Range) |
|---------------------------|------------------------|--|-----------------|
| n4-71<br>(1B8B)<br>Expert | Flux Estimation Method | V/f CL-V/f OLV CLV <b>AOLV</b> OLV/PM AOLV/PM CLV/PM EZOLV<br>Sets the flux estimation method. Usually it is not necessary to change this setting. | 0<br>(0, 1)     |

0 : Method 1

1 : Method 2

### ■ n4-72: Speed Feedback Mode

| No. (Hex.)      | Name                | Description   | Default (Range) |
|-----------------|---------------------|---|-----------------|
| n4-72<br>(1B8C) | Speed Feedback Mode | V/f CL-V/f OLV CLV <b>AOLV</b> OLV/PM AOLV/PM CLV/PM EZOLV<br>Sets the requirement for an encoder option when <i>A1-02 = 4 [Control Method Selection = Advanced Open Loop Vector]</i> . | 0<br>(0, 1)     |

You can connect a PG-B3 or PG-X3 encoder option in AOLV control. You can use the encoder option for better speed control precision.

**Note:**

- When you use an encoder option in AOLV control to operate machinery, specialized tuning of the drive can be necessary. You should usually set *A1-02 = 3 [Control Method Selection = Closed Loop Vector]* when you use an encoder option.
- When you set this parameter to 1, also set the number of PG pulses in *F1-01 [Encoder 1 Pulse Count (PPR)]*.

0 : Without Encoder

1 : With Encoder

### ■ n4-73: PGo Recovery Selection

| No. (Hex.)      | Name                   | Description   | Default (Range) |
|-----------------|------------------------|---|-----------------|
| n4-73<br>(1B8D) | PGo Recovery Selection | V/f CL-V/f OLV CLV <b>AOLV</b> OLV/PM AOLV/PM CLV/PM EZOLV<br>Sets the restart mode to Without Encoder Mode or the With Encoder Mode when an encoder is disconnected. | 0<br>(0, 1)     |

## 2.10 n: Special Adjustment

Set  $A1-02 = 4$  [Control Method Selection = AOLV] and  $n4-72 = 1$  [Speed Feedback Mode = With Encoder] to use this parameter.

Parameter  $F1-02$  [Encoder Signal Loss Detect Sel] sets the drive response when the drive detects a disconnected encoder. This parameter sets the drive to start up in the Without Encoder Mode or With Encoder Mode when the drive detects  $PGo$  [Encoder (PG) Feedback Loss].

**Note:**

A PG-B3 encoder option is necessary to use this parameter. When you use a PG-X3 option, it is not necessary to set this parameter.

If the drive detects  $PGo$ , de-energize the drive and examine the wiring for the encoder.

**0 : Without Encoder**

**1 : With Encoder**

**■ n4-74: Limit of Flux Loop**

| No. (Hex.)   | Name               | Description   | Default (Range)   |
|--------------|--------------------|---|-------------------|
| n4-74 (1B8E) | Limit of Flux Loop | V/f CL-V/f OLV CLV AOLV OLV/PM AOLV/PM CLV/PM EZOLV<br>Sets the control level for flux loop control output. | 250% (100 - 500%) |

If the torque is not sufficient because of 100% or more loads, increase the setting value in 20% increments. If the setting is too high, overexcitation could occur and overheat the motor.

**◆ n5: Feed Forward Control**

Feed forward control increases the responsiveness of acceleration and deceleration as specified by the speed reference.

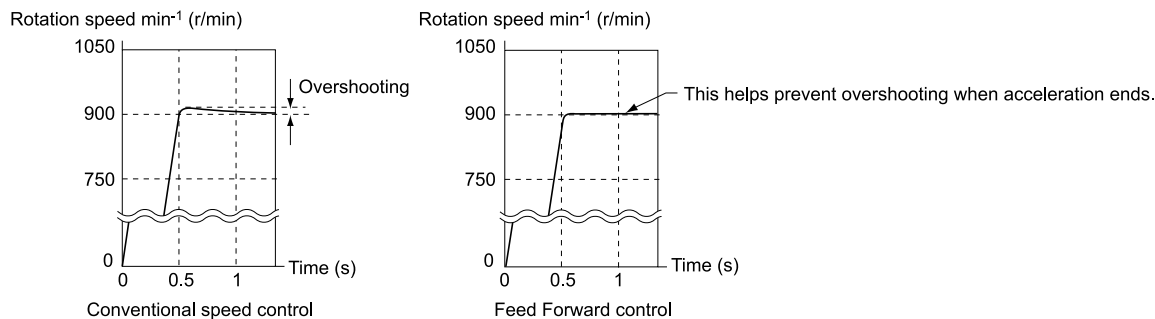
Increase the values set in  $C5-01$  and  $C5-03$  [ASR Proportional Gain] to apply feed forward control to machines that have low rigidity and are possible to have hunting and vibration or to machines that have a large quantity of inertia. When you use this function in CLV control, it also helps prevent overshoot. Refer to Figure 2.144. Refer to Figure 2.145 for more information about parameters related to feed forward control.

Set  $A1-02$  [Control Method Selection] to one of these values to enable feed forward control:

- 3: Closed Loop Vector Control
- 4: Advanced OpenLoop Vector Control
- 6: PM Advanced Open Loop Vector
- 7: PM Closed Loop Vector Control

**Note:**

- You cannot use feed forward control to increase responsiveness in applications where you apply loads externally during run at constant speed.
- When you use the Droop control function, set  $n5-01 = 0$  [Feed Forward Control Selection = Disabled].
- You cannot use feed forward control with motor 2.



**Figure 2.144 Suppress Overshooting with Feed Forward Control**

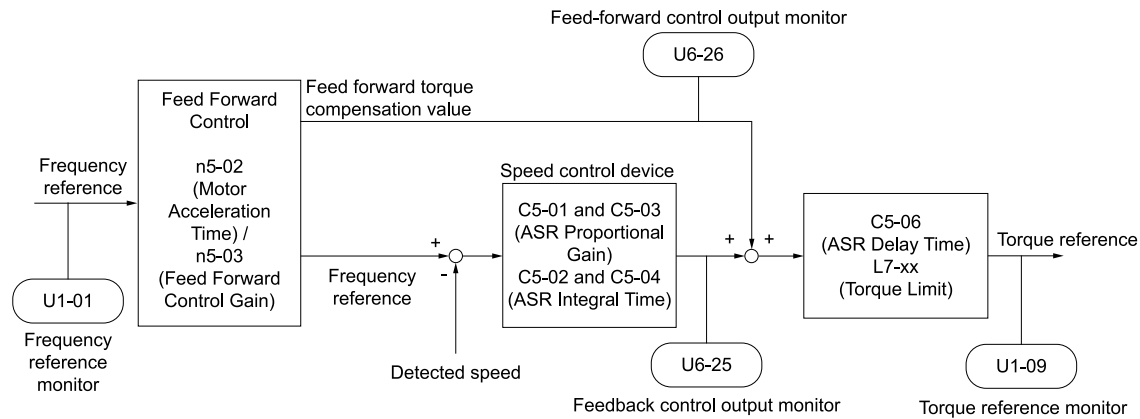


Figure 2.145 Configure Feed Forward Control

■ Before You Use Feed Forward Control

Do one of these procedures before you use feed forward control.

- Run Auto-Tuning to set motor parameters. When you cannot do Auto-Tuning, manually set motor parameters with the information on the motor nameplate or test reports. Set the *E2 parameters* for induction motors. Set the *E5 parameters* for PM motors.
- Set *C5 parameters [Automatic Speed Regulator (ASR)]* individually to adjust the speed control loop (ASR).
- If you can connect a motor to a machine and rotate it during Auto-Tuning, do Inertia Tuning. The drive automatically adjusts feed forward parameters during Inertia Tuning.
- If you cannot do Inertia Tuning, refer to Figure 2.145 and set the parameters related to feed forward control individually.

■ n5-01: Feed Forward Control Selection

| No. (Hex.)   | Name                           | Description  | Default (Range) |
|--------------|--------------------------------|--|-----------------|
| n5-01 (05B0) | Feed Forward Control Selection | V/f CL-V/f OLV CLV AOLV OLV/PM AOLV/PM CLV/PM EZOLV<br>Sets the feed forward function. | 0 (0, 1)        |

0 : Disabled

1 : Enabled

■ n5-02: Motor Inertia Acceleration Time

| No. (Hex.)   | Name                            | Description  | Default (Range)  |
|--------------|---------------------------------|--|--|
| n5-02 (05B1) | Motor Inertia Acceleration Time | V/f CL-V/f OLV CLV AOLV OLV/PM AOLV/PM CLV/PM EZOLV<br>Sets the length of time for the motor to accelerate from the stopped to the maximum frequency with a single motor at the rated torque. Inertia Tuning automatically sets the motor acceleration time. | Determined by C6-01, E5-01, and o2-04 (0.001 - 10.000 s) |

If you cannot do Inertia Tuning, calculate the motor acceleration time as shown here or measure the motor acceleration time and set *n5-02* to this value.

Calculate the Motor Acceleration Time

Use this formula to find the motor acceleration time:

$$n5-02 = \frac{2\pi \cdot J_{\text{Motor}} \cdot n_{\text{rated}}}{60 \cdot T_{\text{rated}}}$$

- $J_{\text{Motor}}$  = Moment of inertia of motor (kg m<sup>2</sup>)
- $n_{\text{rated}}$  = Motor rated speed (min<sup>-1</sup>, r/min)
- $T_{\text{rated}}$  = Motor rated torque (N m)

You can also use this formula to find the motor acceleration time:

## 2.10 n: Special Adjustment

$$n5-02 = \frac{4\pi \cdot J_{\text{Motor}} \cdot f_{\text{rated}}}{p \cdot T_{\text{rated}}}$$

- $f_{\text{rated}}$  = Motor rated frequency (Hz)
- $p$  = Number of motor poles

### Calculate the Motor Acceleration Time

Use this procedure to calculate the motor acceleration time:

1. Use *A1-02 [Control Method Selection]* to set the control method.
2. Disconnect the motor and load.
3. Run Auto-Tuning to set motor parameters.  
When you cannot do Auto-Tuning, manually set motor parameters with the information on the motor nameplate or test reports. Set the *E2 parameters* for induction motors. Set the *E5 parameters* for PM motors.
4. Set *C5 parameters [Automatic Speed Regulator (ASR)]*.
5. Set *C1-01 [Acceleration Time 1] = 0*.
6. Set *L7-01 [Forward Torque Limit]* to 100%.
7. Set the frequency reference to the same value as the motor rated speed.
8. Measure the length of time for the motor to reach the rated speed.  
Show *U1-05 [Motor Speed]* on the keypad and enter the Run command (forward run).
9. Stop the motor.
10. Set *n5-02* to the measured motor acceleration time value.

Reset all of the parameters that you changed to the previous setting values.

### ■ n5-03: Feed Forward Control Gain

| No. (Hex.)   | Name                      | Description   | Default (Range)         |
|--------------|---------------------------|---|-------------------------|
| n5-03 (05B2) | Feed Forward Control Gain | <div style="display: flex; gap: 5px;"> <span>V/f</span> <span>CL-V/f</span> <span>OLV</span> <span>CLV</span> <span>AOLV</span> <span>OLV/PM</span> <span>AOLV/PM</span> <span>CLV/PM</span> <span>EZOLV</span> </div> Sets the ratio between load inertia and motor inertia. Inertia Tuning automatically sets the Feedforward Control Gain value. | 1.00<br>(0.00 - 100.00) |

When you cannot do Inertia Tuning, use this procedure to set n5-03:

Set *n5-02 [Motor Inertia Acceleration Time]*.

1. Connect the motor and load.
2. Set *C1-01 [Acceleration Time 1] = 0*.
3. Use *L7-01 to L7-04 [Torque Limit]* to set the expected test run torque limit levels.
4. Set the frequency reference as specified by the high speed range of the machine.
5. Measure the length of time for the motor to reach the command reference speed.  
Show *U1-05 [Motor Speed]* on the keypad and enter the Run command.
6. Stop the motor.
7. Replace the values in the this formula and set *n5-03* to the value of the formula.

$$n5-03 = \frac{t_{\text{accel}} \cdot T_{\text{Lim\_Test}} \cdot f_{\text{rated}}}{n5-02 \cdot f_{\text{ref\_Test}} \cdot 100} - 1$$

- $t_{\text{accel}}$  = Acceleration time (s)
- $f_{\text{rated}}$  = Motor rated frequency (Hz)
- $T_{\text{Lim\_Test}}$  = Test run torque limit (%)
- $f_{\text{ref\_Test}}$  = Test run frequency reference (Hz)

**WARNING! Sudden Movement Hazard.** Machinery can accelerate suddenly. Do not use this function with machinery that must not accelerate suddenly. Sudden starts can cause serious injury or death.

Reset all of the parameters that you changed to the previous setting values.

**Note:**

- If response to the speed reference is slow, increase the value set in *n5-03*.
- Increase the value set in *n5-03* when response to the speed reference is slow.
  - The speed is overshooting.
  - A negative torque reference is output when acceleration ends.

### ■ n5-04: Speed Response Frequency

| No. (Hex.)                       | Name                     | Description  | Default (Range)                           |
|----------------------------------|--------------------------|--|---|
| n5-04<br>(05B3)<br>RUN<br>Expert | Speed Response Frequency | V/f CL-V/f OLV <b>CLV</b> AOLV OLV/PM AOLV/PM CLV/PM EZOLV<br>Sets the response frequency for the speed reference. Usually it is not necessary to change this parameter. | Determined by A1-02<br>(0.00 - 500.00 Hz) |

If you set *n5-03* [*Feed Forward Control Gain*] too high, the motor speed will momentarily increase to more than the set frequency.

### ◆ n6: Online Tuning

*n6* parameters are used to set the online tuning function for motor line-to-line resistance.

The Online Tuning for motor line-to-line resistance is used to prevent degradation of speed control accuracy due to motor temperature fluctuation and motor stalls due to insufficient torque.

### ■ n6-01: Online Tuning Selection

| No. (Hex.)      | Name                    | Description  | Default (Range) |
|-----------------|-------------------------|--|-----------------|
| n6-01<br>(0570) | Online Tuning Selection | V/f CL-V/f <b>OLV</b> CLV AOLV OLV/PM AOLV/PM CLV/PM EZOLV<br>Sets the type of motor data that Online Tuning uses for OLV control. | 0<br>(0 - 2)    |

#### 0 : Disabled

#### 1 : Line-to-Line Resistance Tuning

The drive adjusts the motor line-to-line resistance during run. This procedure is applicable for speed values 6 Hz and less. It also adjusts the motor resistance value to increase the overload capacity in the low speed range.

#### 2 : Voltage Correction Tuning

The drive adjusts the output voltage during run to increase overload tolerance and minimize the effects of high temperatures on speed precision.

**Note:**

Setting 2 is enabled only when *b8-01* = 0 [*Energy Saving Control Selection = Disabled*].

### ■ n6-05: Online Tuning Gain

| No. (Hex.)                | Name               | Description  | Default (Range)     |
|---------------------------|--------------------|--|---------------------|
| n6-05<br>(05C7)<br>Expert | Online Tuning Gain | V/f CL-V/f <b>OLV</b> CLV AOLV OLV/PM AOLV/PM CLV/PM EZOLV<br>Sets the compensation gain when <i>n6-01</i> = 2 [ <i>Online Tuning Selection = Voltage Correction Tuning</i> ]. Usually it is not necessary to change this parameter. | 1.0<br>(0.1 - 50.0) |

When you use a motor that has a large secondary circuit time constant, decrease the setting value.

If the drive detects *oL1* [*Motor Overload*], increase the setting value in 0.1-unit increments.

### ■ n6-11: Online Resistance Tuning

| No. (Hex.)                | Name                     | Description   | Default (Range)          |
|---------------------------|--------------------------|---|--------------------------|
| n6-11<br>(1B56)<br>Expert | Online Resistance Tuning | V/f CL-V/f OLV <b>CLV</b> AOLV OLV/PM AOLV/PM CLV/PM EZOLV<br>Sets the responsiveness for online resistor tuning. Set this parameter to approximately 1.000 to enable the function. The function is disabled when the value is 0.000. | 0.000<br>(0.000 - 1.000) |

## 2.10 n: Special Adjustment

### ◆ n7: EZ Drive

The *n7 parameters* provide special adjustments for EZ Vector Control.

#### ■ n7-01: Damping Gain for Low Frequency

| No. (Hex.)                | Name                           | Description  | Default (Range)     |
|---------------------------|--------------------------------|--|---------------------|
| n7-01<br>(3111)<br>Expert | Damping Gain for Low Frequency | V/f CL-V/f OLV CLV AOLV OLV/PM AOLV/PM CLV/PM <b>EZOLV</b><br>Sets the oscillation suppression gain for the low speed range. | 1.0<br>(0.1 - 10.0) |

**Note:**

- If oscillation occurs in the low speed range, increase the acceleration time or increase the setting value in 0.5-unit increments.
- To get starting torque with the setting for *C4-01 [Torque Compensation Gain]*, decrease the setting value in 0.3-unit increments.

#### ■ n7-05: Response Gain for Load Changes

| No. (Hex.)                | Name                           | Description  | Default (Range)    |
|---------------------------|--------------------------------|--|--------------------|
| n7-05<br>(3115)<br>Expert | Response Gain for Load Changes | V/f CL-V/f OLV CLV AOLV OLV/PM AOLV/PM CLV/PM <b>EZOLV</b><br>Sets the response gain related to changes in the load. | 100<br>(10 - 1000) |

**Note:**

To make tracking related to load changes better, increase the setting value in 5-unit increments. If oscillation occurs during load changes, decrease the setting value in 5-unit increments.

#### ■ n7-07: Speed Calculation Gain1

| No. (Hex.)                | Name                    | Description   | Default (Range)            |
|---------------------------|-------------------------|---|----------------------------|
| n7-07<br>(3117)<br>Expert | Speed Calculation Gain1 | V/f CL-V/f OLV CLV AOLV OLV/PM AOLV/PM CLV/PM <b>EZOLV</b><br>Sets the speed calculation gain during usual operation. Usually it is not necessary to change this setting. | 15.0 Hz<br>(1.0 - 50.0 Hz) |

#### ■ n7-08: Speed Calculation Gain2

| No. (Hex.)                | Name                    | Description  | Default (Range)            |
|---------------------------|-------------------------|--|----------------------------|
| n7-08<br>(3118)<br>Expert | Speed Calculation Gain2 | V/f CL-V/f OLV CLV AOLV OLV/PM AOLV/PM CLV/PM <b>EZOLV</b><br>Sets the speed calculation gain during a speed search. | 25.0 Hz<br>(1.0 - 50.0 Hz) |

**Note:**

When you increase the setting value, you can do a speed search of a motor rotating at a high frequency. If the setting value is too high, the calculated speed will oscillate and a restart will fail. Decrease the setting value in these conditions.

#### ■ n7-10: Pull-in Current Switching Speed

| No. (Hex.)                | Name                            | Description   | Default (Range)         |
|---------------------------|---------------------------------|---|-------------------------|
| n7-10<br>(311A)<br>Expert | Pull-in Current Switching Speed | V/f CL-V/f OLV CLV AOLV OLV/PM AOLV/PM CLV/PM <b>EZOLV</b><br>Sets a speed range proportional to the rated frequency that enables pull-in current commands. | 10.0%<br>(0.0 - 100.0%) |

**Note:**

- The value set in *n8-51 [Pull-in Current @ Acceleration]* is enabled for speeds that are not higher than the value set in *n7-10*. The value set in *b8-01 [Energy Saving Control Selection]* is enabled for speeds higher than the value set in *n7-10*.
- If there is a large quantity of oscillation when you operate in the low speed range, increase the setting value.
- When it is most important to save energy in the low speed range, decrease the setting value.

### ■ n7-17: Resistance TemperatureCorrection

| No. (Hex.)      | Name                             | Description   | Default (Range) |
|-----------------|----------------------------------|---|-----------------|
| n7-17<br>(3122) | Resistance TemperatureCorrection | V/f CL-V/f OLV CLV AOLV OLV/PM AOLV/PM CLV/PM <b>EZOLV</b><br>Sets the function to adjust for changes in the motor resistance value caused by changes in the temperature. | 1<br>(0 to 2)   |

0 : No

1 : Valid (Only 1 time)

2 : Valid (Every time)

**Note:**

- For settings 1 and 2, the adjustment time can cause a delay before startup.
- For settings 1 and 2, the drive can set the line-to-line resistance value of E9-10 [Motor Line-to-Line Resistance].
- When the temperature will change at startup, use setting 2.
- To shorten the startup time, set this parameter to 0, then do line-to-line resistance tuning.
- If you will start from coasting, set this parameter to 0, then do line-to-line resistance tuning.

### ◆ n8: PM Motor Control Tuning

n8 parameters are used to make adjustments when controlling PM motors.

#### ■ n8-01: Pole Position Detection Current

| No. (Hex.)                | Name                            | Description  | Default (Range)   |
|---------------------------|---------------------------------|--|-------------------|
| n8-01<br>(0540)<br>Expert | Pole Position Detection Current | V/f CL-V/f OLV CLV AOLV <b>OLV/PM AOLV/PM CLV/PM</b> EZOLV<br>Sets, as a percentage, the Initial Rotor Position Estimated Current, taking the E5-03 [Motor Rated Current (FLA)] as the 100% value. Usually it is not necessary to change this setting. | 50%<br>(0 - 100%) |

The drive uses the Initial Rotor Position Estimated Current to detect the initial position of rotors.

If the motor nameplate has an “Si” item, use that value.

**Note:**

If A1-02 = 7 [CLV/PM], this parameter takes effect only in Expert Mode.

#### ■ n8-02: Pole Alignment Current Level

| No. (Hex.)                | Name                         | Description  | Default (Range)   |
|---------------------------|------------------------------|--|-------------------|
| n8-02<br>(0541)<br>Expert | Pole Alignment Current Level | V/f CL-V/f OLV CLV AOLV OLV/PM <b>AOLV/PM CLV/PM</b> EZOLV<br>Sets the current at the time of polar attraction as a percentage of E5-03 [Motor Rated Current (FLA)]. Usually it is not necessary to change this setting. | 80%<br>(0 - 150%) |

The drive uses the polar pull-in current to attract the rotor after it detects the initial rotor position. When you increase the value of n8-02, the starting torque also increases.

- If the motor does not track correctly at the time of the polar attraction, increase the value in 10% increments. If you set the value too high, the drive will detect oL2 [Drive Overloaded].
- If the motor oscillates at the time of the polar attraction, decrease the value in 10% increments.

**Note:**

- This function is available when you set A1-02 = 7 [Control Method Selection = CLV/PM] and do Rotational Auto-Tuning or Z Pulse Offset Tuning.
- If A1-02 = 7, this parameter takes effect only in Expert Mode.

#### ■ n8-03: Pole Position Detection Time

| No. (Hex.)      | Name                         | Description  | Default (Range)        |
|-----------------|------------------------------|--|------------------------|
| n8-03<br>(0542) | Pole Position Detection Time | V/f CL-V/f OLV CLV AOLV OLV/PM AOLV/PM <b>CLV/PM</b> EZOLV<br>Sets the length of the Current Starting Time, which is used for Z Pulse Offset Tuning. Usually it is not necessary to change this setting. | 1.5 s<br>(1.5 - 5.0 s) |

## 2.10 n: Special Adjustment

Sets the length of time of pull-in current when the drive detects the motor magnetic pole of the rotors.

**Note:**

If the motor oscillates at the time of the polar attraction, increase the value in 0.5 s increments. If the value is too high, the drive can detect *oL2 [Drive Overloaded]*.

### ■ n8-04: Pole Alignment Time

| No. (Hex.)                | Name                | Description  | Default (Range)        |
|---------------------------|---------------------|--|------------------------|
| n8-04<br>(0543)<br>Expert | Pole Alignment Time | <div style="display: flex; gap: 5px;"> <span>V/f</span> <span>CL-V/f</span> <span>OLV</span> <span>CLV</span> <span>AOLV</span> <span>OLV/PM</span> <span>AOLV/PM</span> <span>CLV/PM</span> <span>EZOLV</span> </div> <p>Sets the length of the Polar Attraction Time, which is used for Z Pulse Offset Tuning. Usually it is not necessary to change this setting.</p> | 1.5 s<br>(1.5 - 5.0 s) |

Sets the length of time that the pull-in current flows when the drive detects the motor magnetic pole of the rotors.

**Note:**

If the motor oscillates at the time of the polar attraction, increase the value in 0.5 s increments. If you set the value too high, the drive will detect *oL2 [Drive Overloaded]*.

### ■ n8-11: Observer Calculation Gain 2

| No. (Hex.)      | Name                        | Description   | Default (Range)                       |
|-----------------|-----------------------------|---|---------------------------------------|
| n8-11<br>(054A) | Observer Calculation Gain 2 | <div style="display: flex; gap: 5px;"> <span>V/f</span> <span>CL-V/f</span> <span>OLV</span> <span>CLV</span> <span>AOLV</span> <span>OLV/PM</span> <span>AOLV/PM</span> <span>CLV/PM</span> <span>EZOLV</span> </div> <p>Sets the gain for speed estimation. Usually it is not necessary to change this setting.</p> | Determined by n8-72<br>(0.0 - 1000.0) |

**Note:**

When  $n8-72 = 0$  [*Speed Estimation Method Select = Method 1*], the default value is 50.0. When  $n8-72 = 1$  [*Method 2*], the default value is 150.0.

### ■ n8-14: Polarity Compensation Gain 3

| No. (Hex.)                | Name                                    | Description   | Default (Range)           |
|---------------------------|---|---|---------------------------|
| n8-14<br>(054D)<br>Expert | Polarity Compensation Gain <sup>3</sup> | <div style="display: flex; gap: 5px;"> <span>V/f</span> <span>CL-V/f</span> <span>OLV</span> <span>CLV</span> <span>AOLV</span> <span>OLV/PM</span> <span>AOLV/PM</span> <span>CLV/PM</span> <span>EZOLV</span> </div> <p>Sets the gain for speed estimation. Usually it is not necessary to change this setting.</p> | 1.000<br>(0.000 - 10.000) |

### ■ n8-15: Polarity Compensation Gain 4

| No. (Hex.)                | Name                                    | Description   | Default (Range)           |
|---------------------------|---|---|---------------------------|
| n8-15<br>(054E)<br>Expert | Polarity Compensation Gain <sup>4</sup> | <div style="display: flex; gap: 5px;"> <span>V/f</span> <span>CL-V/f</span> <span>OLV</span> <span>CLV</span> <span>AOLV</span> <span>OLV/PM</span> <span>AOLV/PM</span> <span>CLV/PM</span> <span>EZOLV</span> </div> <p>Sets the gain for speed estimation. Usually it is not necessary to change this setting.</p> | 0.500<br>(0.000 - 10.000) |

### ■ n8-21: Motor Back-EMF (Ke) Gain

| No. (Hex.)                | Name                     | Description   | Default (Range)       |
|---------------------------|--------------------------|---|-----------------------|
| n8-21<br>(0554)<br>Expert | Motor Back-EMF (Ke) Gain | <div style="display: flex; gap: 5px;"> <span>V/f</span> <span>CL-V/f</span> <span>OLV</span> <span>CLV</span> <span>AOLV</span> <span>OLV/PM</span> <span>AOLV/PM</span> <span>CLV/PM</span> <span>EZOLV</span> </div> <p>Sets the gain for speed estimation. Usually it is not necessary to change this setting.</p> | 0.90<br>(0.80 - 1.00) |

### ■ n8-23: Polarity ACR q Gain

| No. (Hex.)                | Name                | Description   | Default (Range) |
|---------------------------|---------------------|---|-----------------|
| n8-23<br>(0556)<br>Expert | Polarity ACR q Gain | <div style="display: flex; gap: 5px;"> <span>V/f</span> <span>CL-V/f</span> <span>OLV</span> <span>CLV</span> <span>AOLV</span> <span>OLV/PM</span> <span>AOLV/PM</span> <span>CLV/PM</span> <span>EZOLV</span> </div> <p>Sets the proportional gain for current regulator q-axis control when estimating initial pole. Usually it is not necessary to change this setting.</p> | 0<br>(0 - 2000) |



### ■ n8-24: Polarity ACR qI Time

| No.<br>(Hex.)             | Name                 | Description   | Default<br>(Range)      |
|---------------------------|----------------------|---|-------------------------|
| n8-24<br>(0557)<br>Expert | Polarity ACR qI Time | V/f CL-V/f OLV CLV AOLV <b>OLV/PM</b> AOLV/PM CLV/PM EZOLV<br>Sets the integral time for current regulator q-axis control when estimating initial pole. Usually it is not necessary to change this setting. | 0.0 ms<br>(0.0 - 100.0) |

### ■ n8-25: Polarity ACR q Limit

| No.<br>(Hex.)             | Name                 | Description  | Default<br>(Range) |
|---------------------------|----------------------|--|--------------------|
| n8-25<br>(0558)<br>Expert | Polarity ACR q Limit | V/f CL-V/f OLV CLV AOLV <b>OLV/PM</b> AOLV/PM CLV/PM EZOLV<br>Sets the q-axis limit of the current regulator when estimating initial pole. Usually it is not necessary to change this setting. | 0%<br>(0 - 150)    |

### ■ n8-26: Polarity ACR d Gain

| No.<br>(Hex.)             | Name                | Description   | Default<br>(Range) |
|---------------------------|---------------------|---|--------------------|
| n8-26<br>(0559)<br>Expert | Polarity ACR d Gain | V/f CL-V/f OLV CLV AOLV <b>OLV/PM</b> AOLV/PM CLV/PM EZOLV<br>Sets the proportional gain for current regulator d-axis control when estimating initial pole. Usually it is not necessary to change this setting. | 500<br>(0 - 2000)  |

### ■ n8-27: Polarity ACR dI Time

| No.<br>(Hex.)             | Name                 | Description   | Default<br>(Range)      |
|---------------------------|----------------------|---|-------------------------|
| n8-27<br>(055A)<br>Expert | Polarity ACR dI Time | V/f CL-V/f OLV CLV AOLV <b>OLV/PM</b> AOLV/PM CLV/PM EZOLV<br>Sets the integral time for current regulator d-axis control when estimating initial pole. Usually it is not necessary to change this setting. | 0.0 ms<br>(0.0 - 100.0) |

### ■ n8-28: Polarity ACR d Limit

| No.<br>(Hex.)             | Name                 | Description  | Default<br>(Range) |
|---------------------------|----------------------|--|--------------------|
| n8-28<br>(055B)<br>Expert | Polarity ACR d Limit | V/f CL-V/f OLV CLV AOLV <b>OLV/PM</b> AOLV/PM CLV/PM EZOLV<br>Sets the d-axis limit of the current regulator when estimating initial pole. Usually it is not necessary to change this setting. | 100%<br>(0 - 150)  |

### ■ n8-35: Initial Pole Detection Method

| No.<br>(Hex.)   | Name                          | Description  | Default<br>(Range)             |
|-----------------|-------------------------------|--|--------------------------------|
| n8-35<br>(0562) | Initial Pole Detection Method | V/f CL-V/f OLV CLV AOLV <b>OLV/PM</b> AOLV/PM CLV/PM EZOLV<br>Sets how the drive detects the position of the rotor at start. | Determined by A1-02<br>(0 - 2) |

If you set  $A1-02 = 7$  [Control Method Selection = CLV/PM], the initial motor magnetic pole detection operates the first time after the drive is energized. After that, the drive uses the encoder signal to calculate the rotor position and the drive saves the value until the drive is de-energized. If you use an absolute value encoder, the initial motor magnetic pole detection does not work.

**Note:**

- When you operate an SPM motor, set  $n8-35 = 0$ . When you operate an IPM motor, you can set  $n8-35 = 0$  to 2.
- When you want to set  $n8-35 = 1$ , perform High Frequency Injection Auto-Tuning.
- When you set  $n8-35 = 0$  or 2, carry out an evaluation of the drive and machinery combination being used for the application. If the drive incorrectly detects the polarity, the drive can rotate in the direction opposite of the Run command.

#### 0 : Pull-in

Starts the rotor with pull-in current.

#### 1 : High Frequency Injection

## 2.10 n: Special Adjustment

Injects high frequency to detect the rotor position. This setting can cause a loud excitation sound when the motor starts.

**Note:**

When you set this to 1, perform High Frequency Injection Auto-Tuning.

### 2 : Pulse Injection

Inputs the pulse signal to the motor to detect the rotor position.

#### ■ n8-36: HFI Frequency Level for L Tuning

| No.<br>(Hex.)   | Name                             | Description  | Default<br>(Range)        |
|-----------------|----------------------------------|--|---------------------------|
| n8-36<br>(0563) | HFI Frequency Level for L Tuning | V/f CL-V/f OLV CLV AOLV <b>OLV/PM</b> AOLV/PM CLV/PM EZOLV<br>Sets the injection frequency for high frequency injection. | 500 Hz<br>(200 - 1000 Hz) |

**Note:**

- Set  $n8-35 = 1$  [Initial Pole Detection Method = High Frequency Injection] or  $n8-57 = 1$  [HFI Overlap Selection = Enabled] to enable this parameter.
- The drive automatically calculates this value when High Frequency Injection Auto-Tuning completes successfully.

#### ■ n8-37: HFI Voltage Amplitude Level

| No.<br>(Hex.)             | Name                        | Description  | Default<br>(Range)     |
|---------------------------|-----------------------------|--|------------------------|
| n8-37<br>(0564)<br>Expert | HFI Voltage Amplitude Level | V/f CL-V/f OLV CLV AOLV <b>OLV/PM</b> AOLV/PM CLV/PM EZOLV<br>Sets the high frequency injection amplitude as a percentage where 200 V = 100% for 200 V class drives and 400 V = 100% for a 400 V class drives. Usually it is not necessary to change this setting. | 20.0%<br>(0.0 - 50.0%) |

**Note:**

Set  $n8-35 = 1$  [Initial Pole Detection Method = High Frequency Injection] or  $n8-57 = 1$  [HFI Overlap Selection = Enabled] to enable this parameter.

The drive automatically calculates this value when High Frequency Injection Auto-Tuning completes successfully.

#### ■ n8-39: Low-Pass Filter Shut-Off Frequency for High Frequency Injection

| No.<br>(Hex.)   | Name  | Description   | Default<br>(Range)      |
|-----------------|---|---|-------------------------|
| n8-39<br>(0566) | Low-Pass Filter Shut-Off Frequency for High Frequency Injection | V/f CL-V/f OLV CLV AOLV <b>OLV/PM</b> AOLV/PM CLV/PM EZOLV<br>Sets the low-pass filter shut-off frequency for high frequency injection. | 250 Hz<br>(0 - 1000 Hz) |

**Note:**

- Set  $n8-35 = 1$  [Initial Pole Detection Method = High Frequency Injection] or  $n8-57 = 1$  [HFI Overlap Selection = Enabled] to enable this parameter.
- The drive automatically calculates this value when High Frequency Injection Auto-Tuning completes successfully.

#### ■ n8-41: Response Gain for High Frequency Injection Speed Estimation

| No.<br>(Hex.)             | Name  | Description   | Default<br>(Range)     |
|---------------------------|---|---|------------------------|
| n8-41<br>(0568)<br>Expert | Response Gain for High Frequency Injection Speed Estimation | V/f CL-V/f OLV CLV AOLV <b>OLV/PM</b> AOLV/PM CLV/PM EZOLV<br>Sets the response gain for the high frequency injection speed estimation. | 2.5<br>(-10.0 - +10.0) |

**Note:**

- Set  $n8-35 = 1$  [Initial Pole Detection Method = High Frequency Injection] or  $n8-57 = 1$  [HFI Overlap Selection = Enabled] to enable this parameter.
- Set  $n8-41 > 0.0$  for IPM motors.

Configure the setting as follows.

- Decrease the setting in units of 0.5 if an oscillation or hunting occurs.
- Increase the setting in units of 0.5 if tracking related to load changes is required.

### ■ n8-42: Integral Time Constant for High Frequency Injection Speed Estimation

| No. (Hex.)                | Name   | Description  | Default (Range)           |
|---------------------------|--|--|---------------------------|
| n8-42<br>(0569)<br>Expert | Integral Time Constant for High Frequency Injection Speed Estimation | V/f CL-V/f OLV CLV AOLV <b>OLV/PM</b> AOLV/PM CLV/PM EZOLV<br>Sets the integral time constant for the high frequency injection speed estimation. Usually it is not necessary to change this setting. | 0.10 s<br>(0.00 - 9.99 s) |

**Note:**

Set  $n8-35 = 1$  [Initial Pole Detection Method = High Frequency Injection] or  $n8-57 = 1$  [HFI Overlap Selection = Enabled] to enable this parameter.

### ■ n8-45: Speed Feedback Detection Gain

| No. (Hex.)      | Name                          | Description  | Default (Range)        |
|-----------------|-------------------------------|--|------------------------|
| n8-45<br>(0538) | Speed Feedback Detection Gain | V/f CL-V/f OLV CLV AOLV <b>OLV/PM</b> AOLV/PM CLV/PM EZOLV<br>Sets the internal speed feedback detection reduction unit gain as a magnification value. Usually it is not necessary to change this setting. | 0.80<br>(0.00 - 10.00) |

Adjust this parameter in these conditions:

- If vibration or hunting occur, increase the setting value in 0.05 unit increments.
- If the responsiveness of torque and speed is unsatisfactory, decrease the setting value 0.05 unit increments and examine the response.

### ■ n8-46: Phase Compensation Gain

| No. (Hex.)                | Name                    | Description  | Default (Range)     |
|---------------------------|-------------------------|--|---------------------|
| n8-46<br>(0539)<br>Expert | Phase Compensation Gain | V/f CL-V/f OLV CLV AOLV <b>OLV/PM</b> AOLV/PM CLV/PM EZOLV<br>Sets the gain to compensate for phase differences. Usually it is not necessary to change this setting. | 0.3<br>(0.0 - 10.0) |

If there is vibration in the motor, increase the value. When you must detect *oC* [Overcurrent] or *ov* [DC Bus Overvoltage], set this parameter to a low value.

### ■ n8-47: Pull-in Current Comp Filter Time

| No. (Hex.)      | Name                             | Description   | Default (Range)          |
|-----------------|----------------------------------|---|--------------------------|
| n8-47<br>(053A) | Pull-in Current Comp Filter Time | V/f CL-V/f OLV CLV AOLV <b>OLV/PM</b> AOLV/PM CLV/PM EZOLV<br>Sets the time constant the drive uses to align the pull-in current reference value with the actual current value. Usually it is not necessary to change this setting. | 5.0 s<br>(0.0 - 100.0 s) |

Adjust this parameter in these conditions:

- If the time for the reference value of the pull-in current to align with the target value is too long, increase the setting value.
- If vibration or hunting occur, decrease the setting value in 0.2 unit increments.
- If the motor stalls during run at constant speed, decrease the setting value in 0.2 unit increments.

### ■ n8-48: Pull-in/Light Load Id Current

| No. (Hex.)      | Name                          | Description  | Default (Range)   |
|-----------------|-------------------------------|--|-------------------|
| n8-48<br>(053B) | Pull-in/Light Load Id Current | V/f CL-V/f OLV CLV AOLV <b>OLV/PM</b> AOLV/PM CLV/PM EZOLV<br>On the basis that parameter <i>E5-03</i> [Motor Rated Current (FLA)] is the 100% value, this parameter sets the d-axis current that flows to the motor during run at constant speed as a percentage. | 30%<br>(0 - 200%) |

Adjust in the following situations.

- Slightly reduce this value if there is too much current when driving a light load at a constant speed.
- Increase the setting value in steps of 5% when hunting or vibration occurs during run at constant speed.
- Increase the setting value in steps of 5% if the motor stalls during run at constant speed.

## 2.10 n: Special Adjustment

### ■ n8-49: Heavy Load Id Current

| No. (Hex.)      | Name                                | Description   | Default (Range)                           |
|-----------------|-------------------------------------|---|---|
| n8-49<br>(053C) | d-Axis Cur<br>forHighEfficiencyCont | V/f CL-V/f OLV CLV AOLV <b>OLV/PM</b> AOLV/PM CLV/PM EZOLV<br>Sets the d-axis current to that the drive will supply to the motor to run it at a constant speed with a heavy load. Considers <i>E5-03 [PM Motor Rated Current (FLA)]</i> to be 100%. Usually it is not necessary to change this setting. | Determined by E5-01<br>(-200.0 - +200.0%) |

When you use an IPM motor, you can use the reluctance torque of the motor to make the motor more efficient and help conserve energy.

When you operate an SPN motor, set this parameter to 0.

Adjust this parameter in these conditions:

- If the load is large and motor rotation is not stable, decrease the setting value.
- If you change the *E5 parameters [PM Motor Settings]*, set *n8-49 = 0*, then adjust this parameter.

### ■ n8-50: Heavy Duty I Level

| No. (Hex.)      | Name               | Description  | Default (Range)   |
|-----------------|--------------------|--|-------------------|
| n8-50<br>(053D) | Heavy Duty I Level | V/f CL-V/f OLV CLV AOLV <b>OLV/PM</b> AOLV/PM CLV/PM EZOLV<br>Sets the load current level to start high efficiency control as a percentage of <i>E5-03 [Motor Rated Current]</i> . Usually it is not necessary to change this setting. | 80%<br>(50 - 255) |

### ■ n8-51: Pull-in Current @ Acceleration

| No. (Hex.)      | Name                              | Description  | Default (Range)                   |
|-----------------|-----------------------------------|--|-----------------------------------|
| n8-51<br>(053E) | Pull-in Current @<br>Acceleration | V/f CL-V/f OLV CLV AOLV <b>OLV/PM</b> AOLV/PM CLV/PM <b>EZOLV</b><br>Sets the pull-in current allowed to flow during acceleration/deceleration as a percentage of the motor rated current. | Determined by A1-02<br>(0 - 200%) |

Adjust in the following situations.

- When the motor does not smoothly because of large loads, increase the setting value in 5% increments.
- If too much current flows during acceleration, decrease the setting value.

**Note:**

When *A1-02 = 8 [Control Method Selection = EZOLV]*, this parameter will always be in effect for speed ranges less than *n7-10 [Pull-in Current Switching Speed]*.

### ■ n8-52: ACR Proportional Gain

| No. (Hex.)                | Name                  | Description  | Default (Range)          |
|---------------------------|-----------------------|--|--------------------------|
| n8-52<br>(053F)<br>Expert | ACR Proportional Gain | V/f CL-V/f OLV CLV AOLV <b>OLV/PM</b> AOLV/PM CLV/PM EZOLV<br>Sets the proportional gain of the current regulator. Usually it is not necessary to change this setting. | 10.0<br>(-100.0 - 100.0) |

### ■ n8-54: Voltage Error Compensation Time

| No. (Hex.)                | Name                               | Description   | Default (Range)            |
|---------------------------|------------------------------------|---|----------------------------|
| n8-54<br>(056D)<br>Expert | Voltage Error Compensation<br>Time | V/f CL-V/f OLV CLV AOLV <b>OLV/PM</b> AOLV/PM CLV/PM EZOLV<br>Sets the time constant that the drive uses when adjusting for voltage errors. | 1.00 s<br>(0.00 - 10.00 s) |

Adjust this parameter in these conditions:

- If oscillation occurs at the time of start up, increase the setting value.
- If hunting occurs when operating at low speed, increase the setting value.
- If fast changes in the load cause hunting, increase the setting value in 0.1-unit increments. If you cannot stop hunting, set *n8-51 [Pull-in Current @ Acceleration]* to 0% and set *n8-54* to 0.00 s, and disable compensation for voltage errors.

### ■ n8-55: Motor to Load Inertia Ratio

| No.<br>(Hex.)   | Name                        | Description   | Default<br>(Range) |
|-----------------|-----------------------------|---|--------------------|
| n8-55<br>(056E) | Motor to Load Inertia Ratio | V/f CL-V/f OLV CLV AOLV <b>OLV/PM</b> AOLV/PM CLV/PM EZOLV<br>Sets the ratio between motor inertia and machine inertia. | 0<br>(0 - 3)       |

Adjust in the following situations.

- If torque and speed response is unsatisfactory, gradually increase the setting from 0.
- If the motor does not smoothly, gradually increase the setting from 0.
- If the motor stalls during run at constant speed, gradually increase the setting from 0.
- If there is vibration or hunting, decrease the setting.

**Note:**

- If the value is set too low, the drive will detect *STPo* [*Motor Step-Out Detected*].
- If you use one motor or more than motor at low inertia and the value is too high, there can be vibration in the motor.

#### 0 : Below 1:10

Use this setting in these conditions:

- The ratio between the motor inertia and machine inertia is less than 1:10
- There are large current ripples

#### 1 : Between 1:10 and 1:30

Use this setting in these conditions:

- The ratio between the motor inertia and machine inertia is approximately 1:10 to 1:30
- Parameter  $n8-55 = 0$  and the drive detects *STPo* because of an impact load or sudden acceleration/deceleration.

#### 2 : Between 1:30 and 1:50

Use this setting in these conditions:

- The ratio between the motor inertia and machine inertia is approximately 1:30 to 1:50
- Parameter  $n8-55 = 1$  and the drive detects *STPo* because of an impact load or sudden acceleration/deceleration.

#### 3 : Beyond 1:50

Adjust in the following situations.

- The ratio between the motor inertia and machine inertia is more than 1:50
- Parameter  $n8-55 = 2$  and the drive detects *STPo* because of an impact load or sudden acceleration/deceleration.

### ■ n8-56: Voltage Compensation Control Selection

| No.<br>(Hex.)             | Name                                   | Description  | Default<br>(Range) |
|---------------------------|--|--|--------------------|
| n8-56<br>(056F)<br>Expert | Voltage Compensation Control Selection | V/f CL-V/f OLV CLV AOLV <b>OLV/PM</b> AOLV/PM CLV/PM EZOLV<br>Sets the high efficiency control method for IPM motor. Usually it is not necessary to change this setting. | 1<br>(0 - 2)       |

#### 0 : No

#### 1 : Enabled (Vd)

#### 2 : Enabled (Vd&Vq)

### ■ n8-57: HFI Overlap Selection

| No.<br>(Hex.)   | Name                  | Description   | Default<br>(Range) |
|-----------------|-----------------------|---|--------------------|
| n8-57<br>(0574) | HFI Overlap Selection | V/f CL-V/f OLV CLV AOLV OLV/PM <b>AOLV/PM</b> CLV/PM EZOLV<br>Sets the function that detects motor speed with high frequency injection. | 0<br>(0, 1)        |

## 2.10 n: Special Adjustment

**Note:**

- When you want to set  $n8-57 = 1$ , perform High Frequency Injection Auto-Tuning.
- When there is high frequency injection, the motor will make an excitation sound.
- When you use Zero Speed Control, set  $E1-09$  [Minimum Output Frequency] = 0.0.

### 0 : Disabled

Use this setting with SPM motors. The speed control range is approximately 1:20.

When  $n8-57 = 0$ , you cannot set  $E1-09$  [Minimum Output Frequency]  $\leq 1/20$  of the value of  $E1-06$  [Base Frequency].

### 1 : Enabled

The speed control range changes to 1:100 to allow for speed detection at low speeds.

**Note:**

It is not available with an SPM motor.

## ■ n8-62: Output Voltage Limit Level

| No. (Hex.)                | Name                       | Description  | Default (Range)  |
|---------------------------|----------------------------|--|--|
| n8-62<br>(057D)<br>Expert | Output Voltage Limit Level | V/f CL-V/f OLV CLV AOLV <b>OLV/PM</b> AOLV/PM CLV/PM EZOLV<br>Sets the output voltage limit to prevent saturation of the output voltage. Usually it is not necessary to change this parameter. | 200 V Class: 200.0 V, 400 V Class: 400.0 V<br>(200 V Class: 0.0 to 240.0 V, 400 V Class: 0.0 to 480.0 V) |

Set this parameter lower than the input power supply voltage.

**Note:**

- When  $A1-02 = 7, 8$  [Control Method Selection = CLV/PM, EZOLV], this parameter is available in Expert Mode.
- When  $A1-02 = 8$ , the default setting is  
–200 V Class: 230.0 V  
–400 V Class: 460.0 V

## ■ n8-63: Output V Proportional Gain

| No. (Hex.)                | Name                       | Description  | Default (Range)         |
|---------------------------|----------------------------|--|-------------------------|
| n8-63<br>(057E)<br>Expert | Output V Proportional Gain | V/f CL-V/f OLV CLV AOLV <b>OLV/PM</b> AOLV/PM CLV/PM EZOLV<br>Sets the proportional gain for output voltage control. Usually it is not necessary to change this setting. | 1.00<br>(0.00 - 100.00) |

## ■ n8-64: Output V Integral Time

| No. (Hex.)                | Name                   | Description  | Default (Range)            |
|---------------------------|------------------------|--|----------------------------|
| n8-64<br>(057F)<br>Expert | Output V Integral Time | V/f CL-V/f OLV CLV AOLV <b>OLV/PM</b> AOLV/PM CLV/PM EZOLV<br>Sets the integral time for output voltage control. Usually it is not necessary to change this setting. | 0.040 s<br>(0.000 - 5.000) |

## ■ n8-65: Speed Fdbk Gain @ oV Suppression

| No. (Hex.)                | Name                             | Description  | Default (Range)        |
|---------------------------|----------------------------------|--|------------------------|
| n8-65<br>(065C)<br>Expert | Speed Fdbk Gain @ oV Suppression | V/f CL-V/f OLV CLV AOLV <b>OLV/PM</b> AOLV/PM CLV/PM EZOLV<br>Sets the gain of internal speed feedback detection suppression while the overvoltage suppression function is operating as a magnification value. Usually it is not necessary to change this parameter. | 1.50<br>(0.00 - 10.00) |

Adjust this parameter in these conditions:

- If there is resonance or hunting when you use the overvoltage suppression function, increase the setting value.
- If motor response is low when you use the overvoltage suppression function, decrease the setting value in 0.05-unit increments.

### ■ n8-66: V Limit Output Filter

| No. (Hex.)                | Name                  | Description   | Default (Range)            |
|---------------------------|-----------------------|---|----------------------------|
| n8-66<br>(0235)<br>Expert | V Limit Output Filter | V/f CL-V/f OLV CLV AOLV <b>OLV/PM</b> AOLV/PM CLV/PM EZOLV<br>Sets the filter time constant for output voltage control. Usually it is not necessary to change this setting. | 0.020 s<br>(0.000 - 5.000) |

### ■ n8-69: Speed Observer Control P Gain

| No. (Hex.)                | Name                          | Description   | Default (Range)        |
|---------------------------|-------------------------------|---|------------------------|
| n8-69<br>(065D)<br>Expert | Speed Observer Control P Gain | V/f CL-V/f OLV CLV AOLV OLV/PM <b>AOLV/PM</b> CLV/PM EZOLV<br>Sets the gain that the drive uses for speed estimation. Usually it is not necessary to change this setting. | 1.00<br>(0.00 - 20.00) |

### ■ n8-70: Speed Estimation Integral Time Constant

| No. (Hex.)                | Name                                    | Description   | Default (Range)        |
|---------------------------|---|---|------------------------|
| n8-70<br>(065E)<br>Expert | Speed Estimation Integral Time Constant | V/f CL-V/f OLV CLV AOLV OLV/PM <b>AOLV/PM</b> CLV/PM EZOLV<br>Sets the speed estimator integral time constant. It is available when $n8-72 = 1$ [Initial Pole Detection Method = Method 2]. Usually it is not necessary to change this setting. | 0.0 s<br>(0.0 - 100.0) |

### ■ n8-71: Speed Estimation Differential Gain

| No. (Hex.)                | Name                               | Description   | Default (Range)        |
|---------------------------|------------------------------------|---|------------------------|
| n8-71<br>(065F)<br>Expert | Speed Estimation Differential Gain | V/f CL-V/f OLV CLV AOLV OLV/PM <b>AOLV/PM</b> CLV/PM EZOLV<br>Set the speed estimator differential gain. It is available when $n8-72 = 1$ [Initial Pole Detection Method = Method 2]. Usually it is not necessary to change this setting. | 5.00<br>(0.00 - 50.00) |

### ■ n8-72: Speed Estimation Method Select

| No. (Hex.)                | Name                           | Description  | Default (Range) |
|---------------------------|--------------------------------|--|-----------------|
| n8-72<br>(0655)<br>Expert | Speed Estimation Method Select | V/f CL-V/f OLV CLV AOLV OLV/PM <b>AOLV/PM</b> CLV/PM EZOLV<br>Selects the speed estimation method. Usually it is not necessary to change this setting. | 1<br>(0, 1)     |

0 : Method 1

1 : Method 2

### ■ n8-73: Pull-in Current Reduction Level

| No. (Hex.)                | Name                            | Description  | Default (Range)  |
|---------------------------|---------------------------------|--|------------------|
| n8-73<br>(0656)<br>Expert | Pull-in Current Reduction Level | V/f CL-V/f OLV CLV AOLV OLV/PM <b>AOLV/PM</b> CLV/PM EZOLV<br>Sets the speed level for pull-in current control at motor start as a percentage of $E1-06$ [Base Frequency]. Usually it is not necessary to change this setting. | 10%<br>(0 - 100) |

### ■ n8-74: Light Load Iq Level

| No. (Hex.)      | Name                | Description  | Default (Range)   |
|-----------------|---------------------|--|-------------------|
| n8-74<br>(05C3) | Light Load Iq Level | V/f CL-V/f OLV CLV AOLV <b>OLV/PM</b> AOLV/PM CLV/PM EZOLV<br>Set $n8-48$ [Pull-in/Light Load Id Current] to the level of the load current (q-axis current) to be applied. | 30%<br>(0 - 255%) |

**Note:**

- If  $n8-74 > n8-75$  [Medium Load Iq Level (low)], the drive will detect  $oPE08$  [Parameter Selection Error].
- The change is linear between  $n8-74$  and  $n8-75$  and the level of the pull-in current from  $n8-48$  to  $n8-78$  [Medium Load Id Current].

## 2.10 n: Special Adjustment

### ■ n8-75: Medium Load Iq Level (low)

| No. (Hex.)      | Name                       | Description   | Default (Range)   |
|-----------------|----------------------------|---|-------------------|
| n8-75<br>(05C4) | Medium Load Iq Level (low) | V/f CL-V/f OLV CLV AOLV <b>OLV/PM</b> AOLV/PM CLV/PM EZOLV<br>Set n8-78 [Medium Load Id Current] to the level of the load current (q-axis current) to be applied. | 50%<br>(0 - 255%) |

**Note:**

- If n8-74 [Light Load Iq Level] > n8-75, the drive will detect oPE08 [Parameter Selection Error].
- The change is linear between n8-74 and n8-75 and the level of the pull-in current from n8-48 to n8-78 [Medium Load Id Current].

### ■ n8-76: d-axis I Switching Time Constant

| No. (Hex.)                | Name                             | Description   | Default (Range)      |
|---------------------------|----------------------------------|---|----------------------|
| n8-76<br>(05CD)<br>Expert | d-axis I Switching Time Constant | V/f CL-V/f OLV CLV AOLV <b>OLV/PM</b> AOLV/PM CLV/PM EZOLV<br>Sets the filter time constant for d-axis current reference. Usually it is not necessary to change this setting. | 200 ms<br>(0 - 5000) |

### ■ n8-77: Heavy Load Iq Level

| No. (Hex.)      | Name                | Description  | Default (Range)   |
|-----------------|---------------------|--|-------------------|
| n8-77<br>(05CE) | Heavy Load Iq Level | V/f CL-V/f OLV CLV AOLV <b>OLV/PM</b> AOLV/PM CLV/PM EZOLV<br>Set n8-49 [Heavy Load Id Current] to the level of the load current (q-axis current) to be applied. | 90%<br>(0 - 255%) |

**Note:**

The change is linear between n8-75 [Medium Load Iq Level (low)] and n8-77 and the level of the pull-in current from n8-78 [Medium Load Id Current] to n8-49 [Heavy Load Id Current].

### ■ n8-78: Medium Load Id Current

| No. (Hex.)      | Name                   | Description  | Default (Range)      |
|-----------------|------------------------|--|----------------------|
| n8-78<br>(05F4) | Medium Load Id Current | V/f CL-V/f OLV CLV AOLV <b>OLV/PM</b> AOLV/PM CLV/PM EZOLV<br>Sets the level of the pull-in current for mid-range loads. | 0%<br>(-200 - +200%) |

### ■ n8-79: Pull-in Current @ Deceleration

| No. (Hex.)      | Name                           | Description   | Default (Range)   |
|-----------------|--------------------------------|---|-------------------|
| n8-79<br>(05FE) | Pull-in Current @ Deceleration | V/f CL-V/f OLV CLV AOLV <b>OLV/PM</b> AOLV/PM CLV/PM EZOLV<br>Sets the pull-in current allowed to flow during deceleration as a percentage of the E5-03 [PM Motor Rated Current (FLA)]. | 50%<br>(0 - 200%) |

If overcurrent occurs during deceleration, slowly decrease the setting in 5% increments.

**Note:**

When n8-79 = 0, the drive will use the value set in n8-51 [Pull-in Current @ Acceleration].

### ■ n8-84: Polarity Detection Current

| No. (Hex.)                | Name                       | Description   | Default (Range)    |
|---------------------------|----------------------------|---|--------------------|
| n8-84<br>(02D3)<br>Expert | Polarity Detection Current | V/f CL-V/f OLV CLV AOLV <b>OLV/PM</b> AOLV/PM CLV/PM EZOLV<br>Sets, as a percentage, the current for processing an estimation of the initial motor magnetic pole, assuming that the E5-03 [PM Motor Rated Current] is the 100% value. | 100%<br>(0 - 150%) |

**WARNING! Sudden Movement Hazard.** Make sure that the polarity is correct before you send a Run command. If the drive incorrectly detects the polarity, the drive can rotate in the direction opposite of the Run command and cause serious injury or death.

If you use a Yaskawa motor and the motor nameplate has an "Si" item, set this parameter to a value equal to or more than "Si x 2". Consult the motor manufacturer to determine the maximum values that can be set.



### Find the Polarity of Magnetic Poles

At start, the drive estimates the magnetic poles and finds the polarity of the magnetic poles. When  $A1-02 = 7$  [*Control Method Selection = CLV/PM*], the drive finds the polarity of the magnetic poles only at the first startup.

Check monitor  $U6-57$  [*PolePolarityDeterVal*] to make sure that the drive correctly estimated the polarity of the magnetic poles.

The drive automatically calculates  $n8-84$  when High Frequency Injection Auto-Tuning completes successfully.

### ■ n8-94: Flux Position Estimation Method

| No. (Hex.)                | Name                            | Description   | Default (Range)               |
|---------------------------|---------------------------------|---|-------------------------------|
| n8-94<br>(012D)<br>Expert | Flux Position Estimation Method | V/f CL-V/f OLV CLV AOLV OLV/PM <b>AOLV/PM</b> CLV/PM EZOLV<br>Sets the criteria that the drive uses to find changes in speed or load. Usually it is not necessary to change this setting. | Determined by d5-01<br>(0, 1) |

### 0 : Softstarter

### 1 : Speed Feedback

Set  $n8-57 = 1$  [*HFI Overlap Selection = Enabled*] to enable this parameter. Increases the stability when the speed or load suddenly change, for example with rapid acceleration/deceleration or impact loads.

### ■ n8-95: Flux Position Est Filter Time

| No. (Hex.)                | Name                          | Description  | Default (Range)       |
|---------------------------|-------------------------------|--|-----------------------|
| n8-95<br>(012E)<br>Expert | Flux Position Est Filter Time | V/f CL-V/f OLV CLV AOLV OLV/PM <b>AOLV/PM</b> CLV/PM EZOLV<br>Sets the time constant of the filter used for the recognition criteria value for speed and load changes. Usually it is not necessary to change this setting. | 30 ms<br>(0 - 100 ms) |

#### Note:

Enabled when  $n8-94 = 1$  [*Flux Position Estimation Method = Speed Feedback*].

## 2.11 o: Keypad-Related Settings

*o* parameters set keypad functions.

**Note:**

You cannot set the following parameters with the optional LED keypad.

**Table 2.72 Parameters You Cannot Set with the LED Keypad**

| No.             | Name  | No.             | Name                            |
|-----------------|---|-----------------|---------------------------------|
| o1-05           | LCD Contrast Adjustment                     | o3-04           | Select Backup/Restore Location  |
| o1-24 to o1-35: | Custom Monitor 1 to 12                      | o3-05           | Select Items to Backup/Restore  |
| o1-36           | LCD Backlight Brightness                    | o3-06           | Auto Parameter Backup Selection |
| o1-37           | LCD Backlight ON/OFF Selection              | o3-07           | Auto Parameter Backup Interval  |
| o1-38           | LCD Backlight Off-Delay                     | o4-22           | Time Format                     |
| o1-39           | Show Initial Setup Screen                   | o4-23           | Date Format                     |
| o1-40           | Home Screen Display Selection               | o4-24           | bAT Detection Selection         |
| o1-41 to o1-46: | 1st to 3rd Monitor Area Selections/Settings | o5-01           | Log Start/Stop Selection        |
| o1-47 to o1-51: | Trend Plot 1 or 2 Scale Settings            | o5-02           | Log Sampling Interval           |
| o1-55 to o1-56: | Analog Gauge Area Selection/Setting         | o5-03 to o5-12: | Log Monitor Data 1 to 10        |
| o2-27           | bCE Detection Selection                     |                 |                                 |

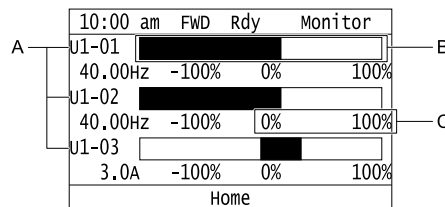
### ◆ o1: Keypad Display Selection

*o1* parameters select the parameters shown on the initial keypad screen and to configure the parameter setting units and display units. These parameters also adjust the backlight and contrast of the LCD display.

#### ■ Home Screen Display Format

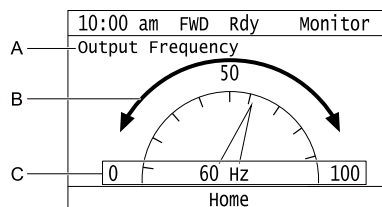
*o1-40* [Home Screen Display Selection] changes the display of the monitor shown on the Home screen. You can show numerical values or one of these three displays on the Home screen monitor:

##### Bar Graph Display



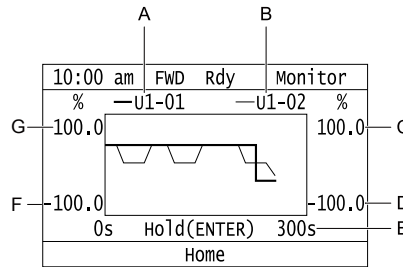
- A - Select *Ux-xx* [Monitors] with *o1-24*, *o1-25*, and *o1-26*.**
- B - Configure display regions with *o1-41*, *o1-43*, and *o1-45*.**
- C - Select display ranges with *o1-42*, *o1-44*, and *o1-46*.**

##### Analog Gauge Display



- A - Select *Ux-xx* [Monitors] with *o1-24*.**
- B - Configure display regions with *o1-55*.**
- C - Select display ranges with *o1-56*.**

Trend Plot Display



- A - Select *Ux-xx* [Monitors] (Monitor 1) with *o1-24*.
- B - Select *Ux-xx* [Monitors] (Monitor 2) with *o1-25*.
- C - Set the maximum value of Monitor 2 with *o1-50*
- D - Set the minimum value of Monitor 2 with *o1-49*
- E - Set the time scale with *o1-51*
- F - Set the minimum value of Monitor 1 with *o1-47*
- G - Set the maximum value of Monitor 1 with *o1-48*

■ **o1-01: User Monitor Selection**

| No. (Hex.)             | Name                   | Description  | Default (Range)    |
|------------------------|------------------------|--|--------------------|
| o1-01<br>(0500)<br>RUN | User Monitor Selection | <b>V/f</b> <b>CL-V/f</b> <b>OLV</b> <b>CLV</b> <b>AOLV</b> <b>OLV/PM</b> <b>AOLV/PM</b> <b>CLV/PM</b> <b>EZOLV</b><br>Sets the <i>U</i> monitor for the Drive Mode. This parameter is only available when you use an LED keypad. | 106<br>(104 - 855) |

When the drive is in Drive Mode, push on the keypad to cycle through the data in this sequence: frequency reference → rotational direction → output frequency → output current → *o1-01* selection.

Set the *x-xx* part of *Ux-xx* that is shown in the fifth position in Drive Mode. For example, to show *U1-05* [Motor Speed], set *o1-01* = 105.

**Note:**

- You cannot select *U2* monitor [Fault Trace] or *U3* Monitor [Fault History].
- The monitors that you can select are different for different control methods.

■ **o1-02: Monitor Selection at Power-up**

| No. (Hex.)             | Name                          | Description   | Default (Range) |
|------------------------|-------------------------------|---|-----------------|
| o1-02<br>(0501)<br>RUN | Monitor Selection at Power-up | <b>V/f</b> <b>CL-V/f</b> <b>OLV</b> <b>CLV</b> <b>AOLV</b> <b>OLV/PM</b> <b>AOLV/PM</b> <b>CLV/PM</b> <b>EZOLV</b><br>Sets the monitor item that the keypad screen shows after energizing the drive. Refer to “U: Monitors” for information about the monitor items that the keypad screen can show. This parameter is only available when you use an LED keypad. | 1<br>(1 - 5)    |

**1 : Frequency Reference (U1-01)**

**2 : Direction**

**3 : Output Frequency (U1-02)**

**4 : Output Current (U1-03)**

**5 : User Monitor (o1-01)**

Shows the monitor item selected in *o1-01* [User Monitor Selection].

■ **o1-03: Frequency Display Unit Selection**

| No. (Hex.)      | Name                             | Description  | Default (Range)                |
|-----------------|----------------------------------|--|--------------------------------|
| o1-03<br>(0502) | Frequency Display Unit Selection | <b>V/f</b> <b>CL-V/f</b> <b>OLV</b> <b>CLV</b> <b>AOLV</b> <b>OLV/PM</b> <b>AOLV/PM</b> <b>CLV/PM</b> <b>EZOLV</b><br>Sets the display units for the frequency reference and output frequency. | Determined by A1-02<br>(0 - 3) |

## 2.11 o: Keypad-Related Settings

**Note:**

- Select the units for the following parameters.
  - d1-01 to d1-17 [Reference 1 to 17]
  - U1-01 [Frequency Reference]
  - U1-02 [Output Frequency]
  - U1-05 [Motor Speed]
  - U1-16 [SFS Output Frequency]
  - U4-14 [PeakHold Output Freq]
  - U6-27 [FeedFwd Estimate Spd]
- For motor 2, the settings are always 0 [in Hz unit].

### 0 : 0.01Hz units

### 1 : 0.01% units

The maximum output frequency is 100%.

### 2 : min<sup>-1</sup> (r/min) unit

The drive uses the maximum output frequency and number of motor poles calculate this value automatically.

**Note:**

When you set o1-03 = 2 [r/min], make sure that you set the number of motor poles in these parameters:

- E2-04 [Motor Pole Count]
- E4-04 [Motor 2 Motor Poles]
- E5-04 [PM Motor Pole Count]
- E9-08 [Number of Poles]

### 3 : User Units

Uses o1-10 and o1-11 to set the unit of measure. The value of parameter o1-10 is the value when you remove the decimal point from the maximum output frequency. Parameter o1-11 is to the number of digits after the decimal point in the maximum output frequency.

To display a maximum output frequency of 100.00, set parameters to these values:

- o1-10 = 10000
- o1-11 = 2 [User Units Decimal Position = 2 Dec (XXX.XX)]

### ■ o1-04: V/f Pattern Display Unit

| No. (Hex.)      | Name                     | Description   | Default (Range)               |
|-----------------|--------------------------|---|-------------------------------|
| o1-04<br>(0503) | V/f Pattern Display Unit | <div style="display: flex; gap: 5px;"> <span>V/f</span> <span>CL-V/f</span> <span>OLV</span> <span>CLV</span> <span>AOLV</span> <span>OLV/PM</span> <span>AOLV/PM</span> <span>CLV/PM</span> <span>EZOLV</span> </div> Sets the setting unit for parameters that set the V/f pattern frequency. | Determined by A1-02<br>(0, 1) |

**Note:**

- Select the units for the following parameters.
  - E1-04 [Maximum Output Frequency]
  - E1-06 [Base Frequency]
  - E1-07 [Mid Point A Frequency]
  - E1-09 [Minimum Output Frequency]
  - E1-11 [Mid Point B Frequency]
  - E9-02 [Maximum Speed]
  - E9-04 [Base Frequency]
- For motor 2, the settings are always 0 [in Hz unit].

### 0 : Hz

### 1 : min<sup>-1</sup> (r/min) unit

If you set o1-04 = 1 [min<sup>-1</sup>(r/min) unit], be sure to set the motor pole count using the following parameters.

- E2-04 [Motor Pole Count]
- E5-04 [PM Motor Pole Count]
- E9-08 [Motor Pole Count]

### ■ o1-05: LCD Contrast Adjustment

| No. (Hex.)             | Name                    | Description   | Default (Range) |
|------------------------|-------------------------|---|-----------------|
| o1-05<br>(0504)<br>RUN | LCD Contrast Adjustment | <b>V/f</b> <b>CL-V/f</b> <b>OLV</b> <b>CLV</b> <b>AOLV</b> <b>OLV/PM</b> <b>AOLV/PM</b> <b>CLV/PM</b> <b>EZOLV</b><br>Sets the contrast of the LCD display on the keypad. | 5<br>(0 - 10)   |

When you decrease the setting value, the contrast of the LCD display decreases. When you increase the setting value, the contrast increases.

### ■ o1-10: User Units Maximum Value

| No. (Hex.)      | Name                     | Description  | Default (Range)                    |
|-----------------|--------------------------|--|------------------------------------|
| o1-10<br>(0520) | User Units Maximum Value | <b>V/f</b> <b>CL-V/f</b> <b>OLV</b> <b>CLV</b> <b>AOLV</b> <b>OLV/PM</b> <b>AOLV/PM</b> <b>CLV/PM</b> <b>EZOLV</b><br>Sets the value that the drive shows as the maximum output frequency. | Determined by o1-03<br>(1 - 60000) |

To display a maximum output frequency of 100.00, set parameters to these values:

- o1-10 = 10000
- o1-11 = 2 [User Units Decimal Position = 2 Dec (XXX.XX)]

**Note:**

Set o1-03 = 3 [Frequency Display Unit Selection = User Units (o1-10 & o1-11)] before you set o1-10 and o1-11.

### ■ o1-11: User Units Decimal Position

| No. (Hex.)      | Name                        | Description   | Default (Range)                |
|-----------------|-----------------------------|---|--------------------------------|
| o1-11<br>(0521) | User Units Decimal Position | <b>V/f</b> <b>CL-V/f</b> <b>OLV</b> <b>CLV</b> <b>AOLV</b> <b>OLV/PM</b> <b>AOLV/PM</b> <b>CLV/PM</b> <b>EZOLV</b><br>Sets the number of decimal places for frequency reference and monitor values. | Determined by o1-03<br>(0 - 3) |

**0 : No Decimal Places (XXXXX)**

**1 : One Decimal Places (XXXX.X)**

**2 : Two Decimal Places (XXX.XX)**

**3 : Three Decimal Places (XX.XXX)**

**Note:**

Set o1-03 = 3 [Frequency Display Unit Selection = User Units (o1-10 & o1-11)] before you set o1-10 [User Units Maximum Value] and o1-11.

### ■ o1-24 to o1-35: Custom Monitor 1 to 12

| No. (Hex.)                              | Name                   | Description  | Default (Range)   |
|---|------------------------|--|---|
| o1-24 to o1-35:<br>(11AD - 11B8)<br>RUN | Custom Monitor 1 to 12 | <b>V/f</b> <b>CL-V/f</b> <b>OLV</b> <b>CLV</b> <b>AOLV</b> <b>OLV/PM</b> <b>AOLV/PM</b> <b>CLV/PM</b> <b>EZOLV</b><br>Sets a maximum of 12 monitors as user monitors. This parameter is only available when using an LCD keypad. | o1-24: 101<br>o1-25: 102<br>o1-26: 103<br>o1-27 to o1-35: 0<br>(0, 101 - 999) |

These parameters save the monitor items selected by the LCD keypad [Custom Monitor].

## 2.11 o: Keypad-Related Settings

**Note:**

- You can show a maximum of three selected monitors on one LCD keypad screen.
  - When you select only one monitor, the text size of this monitor increases. For example, when  $o1-25$  to  $o1-35 = 0$ , the text size of the monitor saved in  $o1-24$  increases.
  - When you select two monitors, the text size of these monitors increase.
  - When you select four or more monitors, the fourth monitor and all additional monitors are shown on the next screens.
- Monitors selected with  $o1-24$  to  $o1-26$  can be displayed as a bar graph, analog gauge, or trend plot.
  - Bar graph display: 3 monitors maximum  
Select with  $o1-24$ ,  $o1-25$ , and  $o1-26$ .
  - Analog gauge display: 1 monitor  
Select with  $o1-24$ .
  - Trend plot display: 2 monitors  
Select with  $o1-24$  and  $o1-25$ .
- You can only set parameters  $o1-24$  to  $o1-26$  with analog output monitors.
- $o1-27$  to  $o1-35$  allow you to select all the monitors.

### ■ o1-36: LCD Backlight Brightness

| No. (Hex.)             | Name                     | Description   | Default (Range) |
|------------------------|--------------------------|---|-----------------|
| o1-36<br>(11B9)<br>RUN | LCD Backlight Brightness | <b>V/f</b> <b>CL-V/f</b> <b>OLV</b> <b>CLV</b> <b>AOLV</b> <b>OLV/PM</b> <b>AOLV/PM</b> <b>CLV/PM</b> <b>EZOLV</b><br>Sets the intensity of the LCD keypad backlight. | 5<br>(1 - 5)    |

When you decrease the setting value, the intensity of the backlight decreases.

### ■ o1-37: LCD Backlight ON/OFF Selection

| No. (Hex.)             | Name                           | Description   | Default (Range) |
|------------------------|--------------------------------|---|-----------------|
| o1-37<br>(11BA)<br>RUN | LCD Backlight ON/OFF Selection | <b>V/f</b> <b>CL-V/f</b> <b>OLV</b> <b>CLV</b> <b>AOLV</b> <b>OLV/PM</b> <b>AOLV/PM</b> <b>CLV/PM</b> <b>EZOLV</b><br>Sets the automatic shut off function for the LCD backlight. | 1<br>(0, 1)     |

**Note:**

Use  $o1-36$  [LCD backlight adjustment] to adjust the intensity of the LCD backlight.

**0 : OFF**

**1 : ON**

Enables the automatic shut off function. The time at which the LCD backlight automatically turns off is configured with  $o1-38$  [Time to turn off LCD backlight].

### ■ o1-37: LCD Backlight ON/OFF Selection

| No. (Hex.)             | Name                           | Description   | Default (Range) |
|------------------------|--------------------------------|---|-----------------|
| o1-37<br>(11BA)<br>RUN | LCD Backlight ON/OFF Selection | <b>V/f</b> <b>CL-V/f</b> <b>OLV</b> <b>CLV</b> <b>AOLV</b> <b>OLV/PM</b> <b>AOLV/PM</b> <b>CLV/PM</b> <b>EZOLV</b><br>Sets the automatic shut off function for the LCD backlight. | 0<br>(0, 1)     |

**Note:**

Use  $o1-36$  [LCD backlight adjustment] to adjust the intensity of the LCD backlight.

**0 : OFF**

**1 : ON**

Enables the automatic shut off function. The time at which the LCD backlight automatically turns off is configured with  $o1-38$  [Time to turn off LCD backlight].

### ■ o1-38: LCD Backlight Off-Delay

| No. (Hex.)             | Name                    | Description  | Default (Range)      |
|------------------------|-------------------------|--|----------------------|
| o1-38<br>(11BB)<br>RUN | LCD Backlight Off-Delay | <b>V/f</b> <b>CL-V/f</b> <b>OLV</b> <b>CLV</b> <b>AOLV</b> <b>OLV/PM</b> <b>AOLV/PM</b> <b>CLV/PM</b> <b>EZOLV</b><br>Sets the time until the LCD backlight automatically turns off. | 60 s<br>(10 - 300 s) |

When  $o1-37 = 1$  [LCD backlight ON/OFF Selection = ON], the backlight will automatically turn off after the time set in  $o1-38$  is expired.

When the backlight is off, push a key on the keypad to temporarily turn the backlight on. After the backlight turns on, it will turn off automatically after the time set in  $o1-38$  is expired.

### ■ o1-39: Show Initial Setup Screen

| No. (Hex.)             | Name                      | Description  | Default (Range) |
|------------------------|---------------------------|--|-----------------|
| o1-39<br>(11BC)<br>RUN | Show Initial Setup Screen | <b>V/f</b> <b>CL-V/f</b> <b>OLV</b> <b>CLV</b> <b>AOLV</b> <b>OLV/PM</b> <b>AOLV/PM</b> <b>CLV/PM</b> <b>EZOLV</b><br>Sets the function to show the LCD keypad initial setup screen each time the drive is energized. This parameter is only available when using an LCD keypad. | 1<br>(0, 1)     |

The initial setup screen shows a menu where you can select the display language, set the date, time, and other basic settings. When you set this parameter to 0, the drive will not show this screen each time you energize the drive.

#### 0 : No

The drive will not show the initial setup display screen each time you energize the drive. The drive will show the Home screen.

#### 1 : Yes

When you input the Run command before you energize the drive or when you turn on the Run command while the drive shows the initial setup screen, the drive will replace the initial setup screen with the Home screen.

### ■ o1-40: Home Screen Display Selection

| No. (Hex.)             | Name                          | Description   | Default (Range) |
|------------------------|-------------------------------|---|-----------------|
| o1-40<br>(11BD)<br>RUN | Home Screen Display Selection | <b>V/f</b> <b>CL-V/f</b> <b>OLV</b> <b>CLV</b> <b>AOLV</b> <b>OLV/PM</b> <b>AOLV/PM</b> <b>CLV/PM</b> <b>EZOLV</b><br>Sets the monitor display mode for the Home screen. This parameter is only available when using an LCD keypad. | 0<br>(0 - 3)    |

#### 0 : Custom Monitor

#### 1 : Bar Graph

#### 2 : Analog Gauge

#### 3 : Trend Plot

### ■ o1-41: 1st Monitor Area Selection

| No. (Hex.)             | Name                       | Description  | Default (Range) |
|------------------------|----------------------------|--|-----------------|
| o1-41<br>(11C1)<br>RUN | 1st Monitor Area Selection | <b>V/f</b> <b>CL-V/f</b> <b>OLV</b> <b>CLV</b> <b>AOLV</b> <b>OLV/PM</b> <b>AOLV/PM</b> <b>CLV/PM</b> <b>EZOLV</b><br>Sets the horizontal range used to display the monitor set in $o1-24$ [Custom Monitor 1] as a bar graph. This parameter is only available when using an LCD keypad. | 0<br>(0 - 2)    |

#### 0 : +/- Area ( - o1-42 ~ o1-42 )

#### 1 : + Area ( 0 ~ o1-42 )

#### 2 : - Area ( - o1-42 ~ 0 )

## 2.11 o: Keypad-Related Settings

### ■ o1-42: 1st Monitor Area Setting

| No.<br>(Hex.)          | Name                     | Description   | Default<br>(Range)       |
|------------------------|--------------------------|---|--------------------------|
| o1-42<br>(11C2)<br>RUN | 1st Monitor Area Setting | <b>V/f</b> <b>CL-V/f</b> <b>OLV</b> <b>CLV</b> <b>AOLV</b> <b>OLV/PM</b> <b>AOLV/PM</b> <b>CLV/PM</b> <b>EZOLV</b><br>Sets the horizontal axis value used to display the monitor set in o1-24 [Custom Monitor 1] as a bar graph. This parameter is only available when using an LCD keypad. | 100.0%<br>(0.0 - 100.0%) |

### ■ o1-43: 2nd Monitor Area Selection

| No.<br>(Hex.)          | Name                       | Description   | Default<br>(Range) |
|------------------------|----------------------------|---|--------------------|
| o1-43<br>(11C3)<br>RUN | 2nd Monitor Area Selection | <b>V/f</b> <b>CL-V/f</b> <b>OLV</b> <b>CLV</b> <b>AOLV</b> <b>OLV/PM</b> <b>AOLV/PM</b> <b>CLV/PM</b> <b>EZOLV</b><br>Selects the horizontal range used to display the monitor set in o1-25 [Custom Monitor 2] as a bar graph. This parameter is only available when using an LCD keypad. | 0<br>(0 - 2)       |

0 : +/- Area ( - o1-44 ~ o1-44 )

1 : + Area ( 0 ~ o1-44 )

2 : - Area ( - o1-44 ~ 0 )

### ■ o1-44: 2nd Monitor Area Setting

| No.<br>(Hex.)          | Name                     | Description   | Default<br>(Range)       |
|------------------------|--------------------------|---|--------------------------|
| o1-44<br>(11C4)<br>RUN | 2nd Monitor Area Setting | <b>V/f</b> <b>CL-V/f</b> <b>OLV</b> <b>CLV</b> <b>AOLV</b> <b>OLV/PM</b> <b>AOLV/PM</b> <b>CLV/PM</b> <b>EZOLV</b><br>Sets the horizontal axis value used to display the monitor set in o1-25 [Custom Monitor 2] as a bar graph. This parameter is only available when using an LCD keypad. | 100.0%<br>(0.0 - 100.0%) |

### ■ o1-45: 3rd Monitor Area Selection

| No.<br>(Hex.)          | Name                       | Description  | Default<br>(Range) |
|------------------------|----------------------------|--|--------------------|
| o1-45<br>(11C5)<br>RUN | 3rd Monitor Area Selection | <b>V/f</b> <b>CL-V/f</b> <b>OLV</b> <b>CLV</b> <b>AOLV</b> <b>OLV/PM</b> <b>AOLV/PM</b> <b>CLV/PM</b> <b>EZOLV</b><br>Sets the horizontal range used to display the monitor set in o1-26 [Custom Monitor 3] as a bar graph. This parameter is only available when using an LCD keypad. | 0<br>(0 - 2)       |

0 : +/- Area ( - o1-46 ~ o1-46 )

1 : + Area ( 0 ~ o1-46 )

2 : - Area ( - o1-46 ~ 0 )

### ■ o1-46: 3rd Monitor Area Setting

| No.<br>(Hex.)          | Name                     | Description   | Default<br>(Range)       |
|------------------------|--------------------------|---|--------------------------|
| o1-46<br>(11C6)<br>RUN | 3rd Monitor Area Setting | <b>V/f</b> <b>CL-V/f</b> <b>OLV</b> <b>CLV</b> <b>AOLV</b> <b>OLV/PM</b> <b>AOLV/PM</b> <b>CLV/PM</b> <b>EZOLV</b><br>Sets the horizontal axis value used to display the monitor set in o1-26 [Custom Monitor 3] as a bar graph. This parameter is only available when using an LCD keypad. | 100.0%<br>(0.0 - 100.0%) |

### ■ o1-47: Trend Plot 1 Scale Minimum Value

| No.<br>(Hex.)          | Name                             | Description  | Default<br>(Range)            |
|------------------------|----------------------------------|--|-------------------------------|
| o1-47<br>(11C7)<br>RUN | Trend Plot 1 Scale Minimum Value | <b>V/f</b> <b>CL-V/f</b> <b>OLV</b> <b>CLV</b> <b>AOLV</b> <b>OLV/PM</b> <b>AOLV/PM</b> <b>CLV/PM</b> <b>EZOLV</b><br>Sets the horizontal axis minimum value used to display the monitor set in o1-24 [Custom Monitor 1] as a trend plot. This parameter is only available when using an LCD keypad. | -100.0%<br>(-300.0 - +300.0%) |



### ■ o1-48: Trend Plot 1 Scale Maximum Value

| No. (Hex.)             | Name                             | Description  | Default (Range)              |
|------------------------|----------------------------------|--|------------------------------|
| o1-48<br>(11C8)<br>RUN | Trend Plot 1 Scale Maximum Value | <b>V/f</b> <b>CL-V/f</b> <b>OLV</b> <b>CLV</b> <b>AOLV</b> <b>OLV/PM</b> <b>AOLV/PM</b> <b>CLV/PM</b> <b>EZOLV</b><br>Sets the horizontal axis maximum value used to display the monitor set in o1-24 [Custom Monitor 1] as a trend plot. This parameter is only available when using an LCD keypad. | 100.0%<br>(-300.0 - +300.0%) |

### ■ o1-49: Trend Plot 2 Scale Minimum Value

| No. (Hex.)             | Name                             | Description  | Default (Range)               |
|------------------------|----------------------------------|--|-------------------------------|
| o1-49<br>(11C9)<br>RUN | Trend Plot 2 Scale Minimum Value | <b>V/f</b> <b>CL-V/f</b> <b>OLV</b> <b>CLV</b> <b>AOLV</b> <b>OLV/PM</b> <b>AOLV/PM</b> <b>CLV/PM</b> <b>EZOLV</b><br>Sets the horizontal axis minimum value used to display the monitor set in o1-25 [Custom Monitor 2] as a trend plot. This parameter is only available when using an LCD keypad. | -100.0%<br>(-300.0 - +300.0%) |

### ■ o1-50: Trend Plot 2 Scale Maximum Value

| No. (Hex.)             | Name                             | Description  | Default (Range)              |
|------------------------|----------------------------------|--|------------------------------|
| o1-50<br>(11CA)<br>RUN | Trend Plot 2 Scale Maximum Value | <b>V/f</b> <b>CL-V/f</b> <b>OLV</b> <b>CLV</b> <b>AOLV</b> <b>OLV/PM</b> <b>AOLV/PM</b> <b>CLV/PM</b> <b>EZOLV</b><br>Sets the horizontal axis maximum value used to display the monitor set in o1-25 [Custom Monitor 2] as a trend plot. This parameter is only available when using an LCD keypad. | 100.0%<br>(-300.0 - +300.0%) |

### ■ o1-51: Trend Plot Time Scale Setting

| No. (Hex.)             | Name                          | Description   | Default (Range)       |
|------------------------|-------------------------------|---|-----------------------|
| o1-51<br>(11CB)<br>RUN | Trend Plot Time Scale Setting | <b>V/f</b> <b>CL-V/f</b> <b>OLV</b> <b>CLV</b> <b>AOLV</b> <b>OLV/PM</b> <b>AOLV/PM</b> <b>CLV/PM</b> <b>EZOLV</b><br>Sets the time scale (horizontal axis) to display the trend plot. When you change this setting, the drive automatically adjusts the data sampling time. This parameter is only available when using an LCD keypad. | 300 s<br>(1 - 3600 s) |

### ■ o1-55: Analog Gauge Area Selection

| No. (Hex.)             | Name                        | Description   | Default (Range) |
|------------------------|-----------------------------|---|-----------------|
| o1-55<br>(11EE)<br>RUN | Analog Gauge Area Selection | <b>V/f</b> <b>CL-V/f</b> <b>OLV</b> <b>CLV</b> <b>AOLV</b> <b>OLV/PM</b> <b>AOLV/PM</b> <b>CLV/PM</b> <b>EZOLV</b><br>Sets the range used to display the monitor set in o1-24 [Custom Monitor 1] as an analog gauge. This parameter is only available when using an LCD keypad. | 1<br>(0, 1)     |

0 : +/- Area ( - o1-56 ~ o1-56 )

1 : + Area ( 0 ~ o1-56 )

### ■ o1-56: Analog Gauge Area Setting

| No. (Hex.)             | Name                      | Description   | Default (Range)          |
|------------------------|---------------------------|---|--------------------------|
| o1-56<br>(11EF)<br>RUN | Analog Gauge Area Setting | <b>V/f</b> <b>CL-V/f</b> <b>OLV</b> <b>CLV</b> <b>AOLV</b> <b>OLV/PM</b> <b>AOLV/PM</b> <b>CLV/PM</b> <b>EZOLV</b><br>Sets the value used to display the monitor set in o1-24 [Custom Monitor 1] as an analog meter. This parameter is only available when using an LCD keypad. | 100.0%<br>(0.0 - 100.0%) |

### ■ o1-58: Motor Power Unit Selection

| No. (Hex.)      | Name                       | Description  | Default (Range) |
|-----------------|----------------------------|--|-----------------|
| o1-58<br>(3125) | Motor Power Unit Selection | <b>V/f</b> <b>CL-V/f</b> <b>OLV</b> <b>CLV</b> <b>AOLV</b> <b>OLV/PM</b> <b>AOLV/PM</b> <b>CLV/PM</b> <b>EZOLV</b><br>Sets the setting unit for parameters that set the motor rated power. | 1<br>(0, 1)     |

The drive shows these parameter values in the set units:

- E2-11 [Motor Rated Power]
- E4-11 [Motor 2 Rated Power]

## 2.11 o: Keypad-Related Settings

- E5-02 [PM Motor Rated Power]
- E9-07 [Motor Rated Power]
- T1-02 [Motor Rated Power]
- T2-04 [PM Motor Rated Power]
- T4-08 [Motor Rated Capacity]

### 0 : kW

Shows the motor output in kW units.

### 1 : HP

Shows the motor output in HP units.

## ◆ o2: Keypad Operation

### ■ o2-01: LO/RE Key Function Selection

| No. (Hex.)   | Name                         | Description   | Default (Range) |
|--------------|------------------------------|---|-----------------|
| o2-01 (0505) | LO/RE Key Function Selection | <br>Sets the function that lets the drive switch between LOCAL and REMOTE Modes using . | 1 (0, 1)        |

#### 0 : Disabled

You cannot use to switch between LOCAL and REMOTE Modes.

#### 1 : Enabled

You can use to switch between LOCAL and REMOTE Modes when the drive is stopped. When LOCAL Mode is selected, on the keypad will come on.

**WARNING! Sudden Movement Hazard.** If you change the control source when  $b1-07 = 1$  [LOCAL/REMOTE Run Selection = Accept Existing RUN Command], the drive can start suddenly. Before you change the control source, remove all personnel from the area around the drive, motor, and load. Sudden starts can cause serious injury or death.

**WARNING! Sudden Movement Hazard.** Fully examine all mechanical and electrical connections before you change o2-01 [LO/RE Key Function Selection] or b1-07 [LOCAL/REMOTE Run Selection]. Sudden starts can cause serious injury or death. If  $b1-07 = 1$  [Accept Existing RUN Command] and there is an active Run command when you switch from LOCAL to REMOTE Mode, the drive can start suddenly.

Table 2.73 Function Settings with o2-01 and b1-07


| Function Selection   | LOCAL/REMOTE Run Selection                 | Switching from LOCAL Mode to REMOTE Mode  | Switching from REMOTE Mode to LOCAL Mode                         |
|----------------------|--|---|--|
| o2-01 = 0 [Disabled] | b1-07 = 0 [Disregard Existing RUN Command] | The drive will not switch modes.  | The drive will not switch modes.                                 |
|                      | b1-07 = 1 [Accept Existing RUN Command]    |   |  |
| o2-01 = 1 [Enabled]  | b1-07 = 0 [Disregard Existing RUN Command] | The drive will not start operating although the Run command is active. When you set Run command to active again, the drive will start to run. | The drive cannot operate because the Run command is not enabled. |
|                      | b1-07 = 1 [Accept Existing RUN Command]    | When the Run command is active, the drive will start to run immediately when the mode switches from LOCAL to REMOTE.                          | The drive cannot operate because the Run command is not enabled. |


### ■ o2-02: STOP Key Function Selection

| No. (Hex.)   | Name                        | Description   | Default (Range) |
|--------------|-----------------------------|---|-----------------|
| o2-02 (0506) | STOP Key Function Selection | <br>Sets the function to stop the drive with the  button on the keypad when the Run command source for the drive is REMOTE (external) and not assigned to the keypad. | 1 (0, 1)        |










#### 0 : Disabled

#### 1 : Enabled

 stays enabled when the Run command source has not been assigned to the keypad.

To start the drive again after you push  to stop operation, turn the external Run command OFF and ON again.

### ■ o2-03: User Parameter Default Value

| No.<br>(Hex.)   | Name                         | Description   | Default<br>(Range) |
|-----------------|------------------------------|---|--------------------|
| o2-03<br>(0507) | User Parameter Default Value |         <br>Sets the function to keep the settings of changed parameters as user parameter defaults to use during initialization. | 0<br>(0 - 2)       |


When you set  $o2-03 = 1$  [*Set defaults*], the drive saves changed parameter settings as user parameter setting values in a part of the memory that is isolated from drive parameters.

When you set  $A1-03 = 1110$  [*Initialize Parameters = User Initialization*] to initialize the drive, the drive resets the internal parameter setting values to those user parameter setting values.

#### 0 : No change


#### 1 : Set defaults

Saves changed parameter setting values as user default settings.










Set  $o2-03 = 1$  and then push  on the keypad to save the user parameter setting values. After the drive saves the setting value,  $o2-03$  automatically resets to 0.

#### 2 : Clear all

Deletes all of the saved user parameter setting values.

Set  $o2-03 = 2$  and then push  on the keypad to clear the user parameter setting values. The drive will automatically reset  $o2-03$  to 0. If you delete the user parameter setting values, you cannot set  $A1-03 = 1110$  to initialize parameters.

### ■ o2-04: Drive Model (KVA) Selection

| No.<br>(Hex.)   | Name                        | Description  | Default<br>(Range)             |
|-----------------|-----------------------------|--|--------------------------------|
| o2-04<br>(0508) | Drive Model (KVA) Selection |         <br>Sets the Drive Model code. Set this parameter after replacing the control board. | Determined by the drive<br>(-) |

**NOTICE:** Set  $o2-04$  [*Drive Model Selection*] correctly. If you set this parameter incorrectly, it will decrease drive performance, cause the protection function to operate incorrectly, and cause damage to the drive.

#### Note:

When the setting value of  $o2-04$  changes, related parameter setting values also change. For details, refer to *Defaults by Drive Model and Duty Rating ND/HD on page 133*.

These tables list the relation between  $o2-04$  setting values and drive models.

| o2-04 Setting | Drive Model | o2-04 Setting | Drive Model |
|---------------|-------------|---------------|-------------|
| 62            | 2004        | 6F            | 2082        |
| 63            | 2006        | 70            | 2110        |
| 64            | 2008        | 72            | 2138        |
| 65            | 2010        | 73            | 2169        |
| 66            | 2012        | 74            | 2211        |
| 67            | 2018        | 75            | 2257        |
| 68            | 2021        | 76            | 2313        |
| 6A            | 2030        | 77            | 2360        |
| 6B            | 2042        | 78            | 2415        |
| 6D            | 2056        | 92            | 4002        |
| 6E            | 2070        | 93            | 4004        |

## 2.11 o: Keypad-Related Settings

| o2-04 Setting | Drive Model | o2-04 Setting | Drive Model |
|---------------|-------------|---------------|-------------|
| 94            | 4005        | A3            | 4103        |
| 95            | 4007        | A4            | 4140        |
| 96            | 4009        | A5            | 4168        |
| 97            | 4012        | A6            | 4208        |
| 99            | 4018        | A7            | 4250        |
| 9A            | 4023        | A8            | 4302        |
| 9C            | 4031        | A9            | 4371        |
| 9D            | 4038        | AA            | 4414        |
| 9E            | 4044        | AC            | 4477        |
| 9F            | 4060        | AD            | 4568        |
| A1            | 4075        | AE            | 4605        |
| A2            | 4089        | AF            | 4720        |

### o2-05: Home Mode Freq Ref Entry Mode

| No. (Hex.)   | Name                          | Description   | Default (Range) |
|--------------|-------------------------------|---|-----------------|
| o2-05 (0509) | Home Mode Freq Ref Entry Mode | <p>Sets the function that makes it necessary to push the  to change the frequency reference value with the keypad when in Drive Mode.</p> | 0<br>(0, 1)     |

#### 0 : ENTER Key Required

You must push to use the keypad to change the frequency reference value.

#### 1 : Immediate / MOP-style

The frequency reference changes when you enter it with the keypad. This then changes the output frequency. It is not necessary to push . The drive keeps the frequency reference for 5 seconds after you use and on the keypad to change the frequency reference value.

### o2-06: Keypad Disconnect Detection

| No. (Hex.)   | Name                        | Description   | Default (Range) |
|--------------|-----------------------------|---|-----------------|
| o2-06 (050A) | Keypad Disconnect Detection | <p>Sets the function that stops the drive if you disconnect the keypad connection cable from the drive or if you damage the cable while the keypad is the Run command source.</p> | 1<br>(0, 1)     |

This parameter continues to operate if the keypad installed to the drive becomes disconnected.

This parameter is enabled in these conditions:

- When  $b1-02 = 0$  [Run Command Selection 1 = Keypad] or  $b1-16 = 0$  [Run Command Selection 2 = Keypad]
- In LOCAL Mode

#### 0 : Disabled

The drive continues operation when it detects a keypad disconnection.

#### 1 : Enabled

The drive stops operation, detects  $oPr$  [Keypad Connection Fault], and the motor coasts to stop when the drive detects a keypad disconnection.

### ■ o2-07: Keypad RUN Direction @ Power-up

| No. (Hex.)      | Name                            | Description  | Default (Range) |
|-----------------|---------------------------------|--|-----------------|
| o2-07<br>(0527) | Keypad RUN Direction @ Power-up | <b>V/f</b> <b>CL-V/f</b> <b>OLV</b> <b>CLV</b> <b>AOLV</b> <b>OLV/PM</b> <b>AOLV/PM</b> <b>CLV/PM</b> <b>EZOLV</b><br>Sets the direction of motor rotation when the drive is energized and the keypad is the Run command source. | 0<br>(0, 1)     |

This parameter is enabled in these conditions:

- When  $b1-02 = 0$  [Run Command Selection 1 = Keypad] or  $b1-16 = 0$  [Run Command Selection 2 = Keypad]
- In LOCAL Mode

**0 : Forward**

**1 : Reverse**

### ■ o2-09: Region Code

| No. (Hex.)      | Name        | Description | Default (Range) |
|-----------------|-------------|-------------|-----------------|
| o2-09<br>(050D) | Region Code | -           | -               |

### ■ o2-23: External 24V Powerloss Detection

| No. (Hex.)             | Name                             | Description  | Default (Range) |
|------------------------|----------------------------------|--|-----------------|
| o2-23<br>(11F8)<br>RUN | External 24V Powerloss Detection | <b>V/f</b> <b>CL-V/f</b> <b>OLV</b> <b>CLV</b> <b>AOLV</b> <b>OLV/PM</b> <b>AOLV/PM</b> <b>CLV/PM</b> <b>EZOLV</b><br>Sets the function to give a warning when the backup external 24 V power supply turns off when the main circuit power supply is in operation. | 0<br>(0, 1)     |

**Note:**

The drive will not run when it is operating from one 24-V external power supply.

**0 : Disabled**

The drive does not detect the loss of the 24-V external power supply.

**1 : Enabled**

The keypad shows the  $L24v$  [Ext. 24-V Power Supply Lost] indicator when the drive detects the loss of the 24-V external power supply.

**Note:**

The minor fault signal is not output from  $H2-xx = 10$  [Multi-Function Digital Out = Minor Fault].

### ■ o2-24: LED Light Function Selection

| No. (Hex.)      | Name                         | Description  | Default (Range) |
|-----------------|------------------------------|--|-----------------|
| o2-24<br>(11FE) | LED Light Function Selection | <b>V/f</b> <b>CL-V/f</b> <b>OLV</b> <b>CLV</b> <b>AOLV</b> <b>OLV/PM</b> <b>AOLV/PM</b> <b>CLV/PM</b> <b>EZOLV</b><br>Sets the function to show the LED status rings and keypad LED lamps. | 2<br>(0 - 2)    |

**0 : Enable Status Ring & Keypad LED**

**1 : LED Status Ring Disable**

**2 : Keypad LED Light Disable**

### ■ o2-26: Alarm display at ext. 24V power

| No. (Hex.)      | Name                            | Description  | Default (Range) |
|-----------------|---------------------------------|--|-----------------|
| o2-26<br>(1563) | Alarm display at ext. 24V power | <b>V/f</b> <b>CL-V/f</b> <b>OLV</b> <b>CLV</b> <b>AOLV</b> <b>OLV/PM</b> <b>AOLV/PM</b> <b>CLV/PM</b> <b>EZOLV</b><br>When you connect a backup external 24 V power supply, this parameter sets the function to trigger an alarm when the main circuit power supply voltage decreases. | 1<br>(0, 1)     |

**0 : No**

## 2.11 o: Keypad-Related Settings

The drive will not detect *EP24v* [External Power 24V Supply] if the main circuit power supply voltage decreases. The [Ready] light on the LED Status Ring flashes quickly to identify that drive operation is not possible.

### 1 : Yes

The drive detects *EP24v* when the main circuit power supply voltage decreases.

#### Note:

The minor fault signal is not output from *H2-xx = 10* [MFDO Function Selection = Minor Fault].

### o2-27: bCE Detection Selection

| No. (Hex.)      | Name                    | Description  | Default (Range) |
|-----------------|-------------------------|--|-----------------|
| o2-27<br>(1565) | bCE Detection Selection | <div style="display: flex; gap: 5px;"> <span>V/f</span> <span>CL-V/f</span> <span>OLV</span> <span>CLV</span> <span>AOLV</span> <span>OLV/PM</span> <span>AOLV/PM</span> <span>CLV/PM</span> <span>EZOLV</span> </div> <p>Sets drive operation if the Bluetooth device is disconnected when you operate the drive in Bluetooth Mode.</p> | 3<br>(0 - 4)    |

### 0 : Ramp to Stop

### 1 : Coast to Stop

### 2 : Fast Stop (Use C1-09)

### 3 : Alarm Only

### 4 : No Alarm Display

## o3: Copy Function

*o3* parameters set the operation of the parameter backup function.

### o3-01: Copy Keypad Function Selection

| No. (Hex.)      | Name                           | Description  | Default (Range) |
|-----------------|--------------------------------|--|-----------------|
| o3-01<br>(0515) | Copy Keypad Function Selection | <div style="display: flex; gap: 5px;"> <span>V/f</span> <span>CL-V/f</span> <span>OLV</span> <span>CLV</span> <span>AOLV</span> <span>OLV/PM</span> <span>AOLV/PM</span> <span>CLV/PM</span> <span>EZOLV</span> </div> <p>Sets the function that saves and copies drive parameters to a different drive with the keypad.</p> | 0<br>(0 - 4)    |

### 0 : Copy Select

### 1 : Backup (drive → keypad)

The parameter setting values are read from the drive and saved in the keypad.

### 2 : Restore (keypad → drive)

Copies the parameter setting values saved in the keypad to a different drive.

### 3 : Verify (check for mismatch)

Makes sure that the parameter setting values in the drive agree with the parameters saved in the keypad.

### 4 : Erase (backup data of keypad)

Deletes the parameter setting values saved in the keypad.

### o3-02: Copy Allowed Selection

| No. (Hex.)      | Name                   | Description  | Default (Range) |
|-----------------|------------------------|--|-----------------|
| o3-02<br>(0516) | Copy Allowed Selection | <div style="display: flex; gap: 5px;"> <span>V/f</span> <span>CL-V/f</span> <span>OLV</span> <span>CLV</span> <span>AOLV</span> <span>OLV/PM</span> <span>AOLV/PM</span> <span>CLV/PM</span> <span>EZOLV</span> </div> <p>Sets the copy function when <i>o3-01 = 1</i> [Copy Keypad Function Selection = Backup (drive → keypad)].</p> | 0<br>(0, 1)     |


#### Note:

When you select [Parameter Backup] on the keypad menu screen to do the backup function, the drive automatically sets *o3-02 = 1*.

### 0 : Disabled

### 1 : Enabled

### ■ o3-04: Select Backup/Restore Location

| No.<br>(Hex.)   | Name                           | Description  | Default<br>(Range) |
|-----------------|--------------------------------|--|--------------------|
| o3-04<br>(0B3E) | Select Backup/Restore Location | <br>Sets the storage location for drive parameters when you back up and restore parameters. This parameter is only available when using an LCD keypad. | 0<br>(0 - 3)       |

You can use the LCD keypad to make a maximum of 4 parameter backup sets.


**0 : Memory Location 1**

**1 : Memory Location 2**

**2 : Memory Location 3**

**3 : Memory Location 4**

### ■ o3-05: Select Items to Backup/Restore

| No.<br>(Hex.)   | Name                           | Description   | Default<br>(Range) |
|-----------------|--------------------------------|---|--------------------|
| o3-05<br>(0BDA) | Select Items to Backup/Restore | <br>Sets which parameters are backed up, restored, and referenced. This parameter is only available when using an LCD keypad. | 1<br>(0, 1)        |


**0 : Standard Parameters**

**1 : Standard + DWEZ Parameters**

**Note:**

- Parameters *qx-xx* [DriveWorksEZ Parameters] and *rx-xx* [DriveWorksEZ Connections] show when *A1-07 = 1 or 2* [DriveWorksEZ Function Selection = DWEZ Enabled or Enabled/Disabled wDigital Input].
- The password for DriveWorksEZ PC software is necessary to back up *qx-xx* and *rx-xx*. If you enter an incorrect password, the drive detects *PWEr* [DWEZ Password Mismatch].

### ■ o3-06: Auto Parameter Backup Selection

| No.<br>(Hex.)   | Name                            | Description  | Default<br>(Range) |
|-----------------|---------------------------------|--|--------------------|
| o3-06<br>(0BDE) | Auto Parameter Backup Selection | <br>Sets the function that automatically backs up parameters. This parameter is only available when using an LCD keypad. | 1<br>(0, 1)        |

When you connect the drive and keypad, parameters set to the drive are automatically backed up to the keypad as specified by the setting of parameters *o3-06* and *o3-07*.


**0 : Disabled**

**1 : Enabled**

**Note:**

When you replace the LCD keypad then energize the drive, the keypad shows the restore operation screen automatically to restore the drive configuration with the parameters backed up to the LCD keypad. If you connect an LCD keypad that does not have parameter backup data, the keypad will not show the restore operation screen.

### ■ o3-07: Auto Parameter Backup Interval

| No.<br>(Hex.)   | Name                           | Description   | Default<br>(Range) |
|-----------------|--------------------------------|---|--------------------|
| o3-07<br>(0BDF) | Auto Parameter Backup Interval | <br>Sets the interval at which the automatic parameter backup function saves parameters from the drive to the keypad. | 1<br>(0 - 3)       |

The drive saves parameter settings to the keypad at these times:

- After you energize the drive and the auto backup period passes.
- When you use ROM enter or the keypad to change parameters, the drive saves those changes in the drive, waits for the auto backup period to pass, then saves those parameters in the keypad.

## 2.11 o: Keypad-Related Settings

**Note:**

The drive can write data to the keypad a maximum of 100,000 times. If you write data to the keypad more than 100,000 times, you must replace the keypad.

**0 : Every 10 minutes**

**1 : Every 30 minutes**

**2 : Every 60 minutes**

**3 : Every 12 hours**

### ◆ o4: Maintenance Mon Settings

*o4 parameters* set the expected service life to help you know when to replace parts. The drive will show an alarm to tell you when the replacement part interval is near.

#### ■ o4-01: Elapsed Operating Time Setting

| No.<br>(Hex.)   | Name                           | Description   | Default<br>(Range)  |
|-----------------|--------------------------------|---|---------------------|
| o4-01<br>(050B) | Elapsed Operating Time Setting | <b>V/f</b> <b>CL-V/f</b> <b>OLV</b> <b>CLV</b> <b>AOLV</b> <b>OLV/PM</b> <b>AOLV/PM</b> <b>CLV/PM</b> <b>EZOLV</b><br>Sets the initial value of the cumulative drive operation time in 10-hour units. | 0 h<br>(0 - 9999 h) |

When you select *o4-01* on the keypad, it will show the current value of *U4-01* in units of 10 hours (h). When you change the setting of *o4-01* through the monitor, the *U4-01* count starts again as specified by the setting of *o4-01*.

**Note:**

Set this parameter in 10-hour (h) units. When *o4-01* = 30, *U4-01* [Cumulative Ope Time] = 300 h.

#### ■ o4-02: Elapsed Operating Time Selection

| No.<br>(Hex.)   | Name                             | Description   | Default<br>(Range) |
|-----------------|----------------------------------|---|--------------------|
| o4-02<br>(050C) | Elapsed Operating Time Selection | <b>V/f</b> <b>CL-V/f</b> <b>OLV</b> <b>CLV</b> <b>AOLV</b> <b>OLV/PM</b> <b>AOLV/PM</b> <b>CLV/PM</b> <b>EZOLV</b><br>Sets the condition that counts the cumulative operation time. | 0<br>(0, 1)        |

#### 0 : U4-01 Shows Total Power-up Time

Counts the time from when the drive is energized to when it is de-energized.

#### 1 : U4-01 Shows Total RUN Time

Counts the time that the drive outputs voltage.

#### ■ o4-03: Fan Operation Time Setting

| No.<br>(Hex.)   | Name                       | Description  | Default<br>(Range)  |
|-----------------|----------------------------|--|---------------------|
| o4-03<br>(050E) | Fan Operation Time Setting | <b>V/f</b> <b>CL-V/f</b> <b>OLV</b> <b>CLV</b> <b>AOLV</b> <b>OLV/PM</b> <b>AOLV/PM</b> <b>CLV/PM</b> <b>EZOLV</b><br>Sets the value from which to start the cumulative drive cooling fan operation time in 10-hour units. | 0 h<br>(0 - 9999 h) |

Use monitor *U4-03* [Cooling Fan Ope Time] to view the total operation time of the cooling fan. When you replace a cooling fan, set *o4-03* = 0 to reset the value of *U4-03*. Select *o4-03* on the keypad to show the current value of *U4-03* in 10-hour (h) units. If you use the monitor to change the *o4-03* setting, the recount of *U4-03* starts with the *o4-03* setting.

**Note:**

The drive sets *o4-03* in 10-hour (h) units. When *o4-03* = 30, *U4-03* [Cooling Fan Ope Time] will show "300 h".

#### ■ o4-05: Capacitor Maintenance Setting

| No.<br>(Hex.)   | Name                          | Description   | Default<br>(Range) |
|-----------------|-------------------------------|---|--------------------|
| o4-05<br>(051D) | Capacitor Maintenance Setting | <b>V/f</b> <b>CL-V/f</b> <b>OLV</b> <b>CLV</b> <b>AOLV</b> <b>OLV/PM</b> <b>AOLV/PM</b> <b>CLV/PM</b> <b>EZOLV</b><br>Sets the <i>U4-05</i> [CapacitorMaintenance] monitor value. | 0%<br>(0 - 150%)   |



When you replace a drive, set  $o4-05 = 0$  to reset the value of  $U4-05$ . When the  $o4-05$  setting changes, the count of  $U4-05$  starts again as specified by the setting of  $o4-05$ . After you complete the configuration, the setting value of  $o4-05$  automatically resets to  $0$ .

**Note:**

The maintenance period changes for different operating environments.

### ■ o4-07: Softcharge Relay Maintenance Set

| No. (Hex.)      | Name                             | Description   | Default (Range)  |
|-----------------|----------------------------------|---|------------------|
| o4-07<br>(0523) | Softcharge Relay Maintenance Set | <b>V/f</b> <b>CL-V/f</b> <b>OLV</b> <b>CLV</b> <b>AOLV</b> <b>OLV/PM</b> <b>AOLV/PM</b> <b>CLV/PM</b> <b>EZOLV</b><br>Sets the $U4-06$ [ <i>PreChargeRelayMainte</i> ] monitor value. | 0%<br>(0 - 150%) |

When you replace a drive, set  $o4-07 = 0$  to reset the value of  $U4-06$ . When the  $o4-07$  setting changes, the count of  $U4-06$  starts again as specified by the setting of  $o4-07$ . After you complete the configuration, the setting value of  $o4-07$  automatically resets to  $0$ .

**Note:**

The maintenance period changes for different operating environments.

### ■ o4-09: IGBT Maintenance Setting

| No. (Hex.)      | Name                     | Description   | Default (Range)  |
|-----------------|--------------------------|---|------------------|
| o4-09<br>(0525) | IGBT Maintenance Setting | <b>V/f</b> <b>CL-V/f</b> <b>OLV</b> <b>CLV</b> <b>AOLV</b> <b>OLV/PM</b> <b>AOLV/PM</b> <b>CLV/PM</b> <b>EZOLV</b><br>Sets the $U4-07$ [ <i>IGBT Maintenance</i> ] monitor value. | 0%<br>(0 - 150%) |

When you replace a drive, set  $o4-09 = 0$  to reset the value of  $U4-07$ . When the setting of  $o4-09$  is changed, the recount of  $U4-07$  starts in accordance with the setting of  $o4-09$ . After you complete the configuration, the setting value of  $o4-09$  automatically resets to  $0$ .

**Note:**

The maintenance period changes for different operating environments.

### ■ o4-11: Fault Trace/History Init (U2/U3)

| No. (Hex.)      | Name                             | Description   | Default (Range) |
|-----------------|----------------------------------|---|-----------------|
| o4-11<br>(0510) | Fault Trace/History Init (U2/U3) | <b>V/f</b> <b>CL-V/f</b> <b>OLV</b> <b>CLV</b> <b>AOLV</b> <b>OLV/PM</b> <b>AOLV/PM</b> <b>CLV/PM</b> <b>EZOLV</b><br>Resets the records of Monitors $U2-xx$ [ <i>Fault Trace</i> ] and $U3-xx$ [ <i>Fault History</i> ]. | 0<br>(0, 1)     |

**Note:**

When you initialize the drive with  $A1-03$  [*Initialize Parameters*], the drive will not reset the records for  $U2-xx$  and  $U3-xx$ .

#### 0 : Disabled

Keeps the records of Monitors  $U2-xx$  and  $U3-xx$ .

#### 1 : Enabled

Resets the records for Monitors  $U2-xx$  and  $U3-xx$ . After the reset, the drive automatically resets  $o4-11$  to  $0$ .

### ■ o4-12: kWh Monitor Initialization

| No. (Hex.)      | Name                       | Description  | Default (Range) |
|-----------------|----------------------------|--|-----------------|
| o4-12<br>(0512) | kWh Monitor Initialization | <b>V/f</b> <b>CL-V/f</b> <b>OLV</b> <b>CLV</b> <b>AOLV</b> <b>OLV/PM</b> <b>AOLV/PM</b> <b>CLV/PM</b> <b>EZOLV</b><br>Resets the monitor values for $U4-10$ [ <i>kWh, Lower 4 Digits</i> ] and $U4-11$ [ <i>kWh, Upper 5 Digits</i> ]. | 0<br>(0, 1)     |

**Note:**

When you initialize the drive with  $A1-03$  [*Initialize Parameters*], the drive will not reset  $U4-10$  and  $U4-11$ .

#### 0 : No Reset

Keeps the monitor values for  $U4-10$  and  $U4-11$ .

#### 1 : Reset

## 2.11 o: Keypad-Related Settings

Resets the values of *U4-10* and *U4-11*. After the reset, the drive automatically resets *o4-12* to 0.

### ■ o4-13: RUN Command Counter @ Initialize

| No. (Hex.)      | Name                             | Description  | Default (Range) |
|-----------------|----------------------------------|--|-----------------|
| o4-13<br>(0528) | RUN Command Counter @ Initialize | <b>V/f</b> <b>CL-V/f</b> <b>OLV</b> <b>CLV</b> <b>AOLV</b> <b>OLV/PM</b> <b>AOLV/PM</b> <b>CLV/PM</b> <b>EZOLV</b><br>Resets the monitor values for <i>U4-02</i> [Num of Run Commands], <i>U4-24</i> [Number of Runs (Low)], and <i>U4-25</i> [Number of Runs (High)]. | 0<br>(0, 1)     |

#### 0 : No Reset

Keeps the monitor values for *U4-02*, *U4-24*, and *U4-25*.

#### 1 : Reset

Resets the values of *U4-02*, *U4-24*, and *U4-25*. After the reset, the drive automatically resets *o4-13* to 0.

### ■ o4-22: Time Format

| No. (Hex.)             | Name        | Description  | Default (Range) |
|------------------------|-------------|--|-----------------|
| o4-22<br>(154F)<br>RUN | Time Format | <b>V/f</b> <b>CL-V/f</b> <b>OLV</b> <b>CLV</b> <b>AOLV</b> <b>OLV/PM</b> <b>AOLV/PM</b> <b>CLV/PM</b> <b>EZOLV</b><br>Sets the time display format. This parameter is only available when using an LCD keypad. | 1<br>(0 - 2)    |

Sets the display of the time shown in the upper-left of the LCD keypad screen.

#### 0 : 24 Hour Clock

#### 1 : 12 Hour Clock

#### 2 : 12 Hour JP Clock

### ■ o4-23: Date Format

| No. (Hex.)             | Name        | Description  | Default (Range) |
|------------------------|-------------|--|-----------------|
| o4-23<br>(1550)<br>RUN | Date Format | <b>V/f</b> <b>CL-V/f</b> <b>OLV</b> <b>CLV</b> <b>AOLV</b> <b>OLV/PM</b> <b>AOLV/PM</b> <b>CLV/PM</b> <b>EZOLV</b><br>Sets the date display format. This parameter is only available when using an LCD keypad. | 2<br>(0 - 2)    |

Sets the date format that the drive uses for the fault history and other records.

#### 0 : YYYY/MM/DD(2016/01/31)

#### 1 : DD/MM/YYYY(31/01/2016)

#### 2 : MM/DD/YYYY

#### Note:

The Fault History in the Monitor Mode shows when faults occurred. Refer to *Show Fault History* on page 581 for more information.

### ■ o4-24: bAT Detection Selection

| No. (Hex.)             | Name                    | Description   | Default (Range) |
|------------------------|-------------------------|---|-----------------|
| o4-24<br>(310F)<br>RUN | bAT Detection Selection | <b>V/f</b> <b>CL-V/f</b> <b>OLV</b> <b>CLV</b> <b>AOLV</b> <b>OLV/PM</b> <b>AOLV/PM</b> <b>CLV/PM</b> <b>EZOLV</b><br>Sets operation when the drive detects <i>bAT</i> [Keypad Battery Low Voltage] and <i>TiM</i> [Keypad Time Not Set]. | 0<br>(0 - 2)    |

#### 0 : Disable

The drive will not detect *bAT* or *TiM*.

#### 1 : Enable (Alarm Detected)

*TiM* or *bAT* shows on the keypad, and operation continues. The output terminal set for Alarm [*H2-01* to *H2-03* = 10] activates.

#### 2 : Enable (Fault Detected)

The drive output shuts off and the motor coasts to stop. Fault relay output terminal MA-MC activates, and MB-MC deactivates.

## ◆ o5: Log Function

The data log function saves drive status information as a CSV file in the micro SD memory card in the keypad. *Monitors Ux-xx* are the source of data log information. You can record a maximum of 10 monitors.

Change the LCD keypad screen from the main menu to the Diagnostic Tools screen and select the data log function. Set the number of the monitor to record and the sampling time, then start to record the data log.

**Table 2.74 Setting Parameters for Data Log Items**

| No.          | Name                | Default | Data Log Monitors                  |
|--------------|---------------------|---------|------------------------------------|
| <i>o5-03</i> | Log Monitor Data 1  | 101     | <i>U1-01 [Frequency Reference]</i> |
| <i>o5-04</i> | Log Monitor Data 2  | 102     | <i>U1-02 [Output Frequency]</i>    |
| <i>o5-05</i> | Log Monitor Data 3  | 103     | <i>U1-03 [Output Current]</i>      |
| <i>o5-06</i> | Log Monitor Data 4  | 107     | <i>U1-07 [DC Bus Voltage]</i>      |
| <i>o5-07</i> | Log Monitor Data 5  | 108     | <i>U1-08 [Output Power]</i>        |
| <i>o5-08</i> | Log Monitor Data 6  | 000     | Not selected                       |
| <i>o5-09</i> | Log Monitor Data 7  | 000     | Not selected                       |
| <i>o5-10</i> | Log Monitor Data 8  | 000     | Not selected                       |
| <i>o5-11</i> | Log Monitor Data 9  | 000     | Not selected                       |
| <i>o5-12</i> | Log Monitor Data 10 | 000     | Not selected                       |

### Note:

- Failure to obey can cause the log function to fail after you restore power or connect the keypad. Do not de-energize the drive or disconnect the keypad from the drive during log transfer communication.
- You can use a Micro SDHC card a maximum of 32 GB capacity.

## ■ Log File Specifications

| Item                    | Specification  |
|-------------------------|--|
| File storage location   | A folder called [Log_File] is created in the root directory of the micro SD card.  |
| Filename                | GLOG0xxx.csv<br><b>Note:</b><br>[xxx] identifies a 3-digit decimal number  |
| Maximum number of files | 999 (GLOG0001.csv through GLOG0999.csv)  |
| Character code          | ASCII code   |
| Line break code         | <CR><LF>   |
| Separating character    | Commas   |
| Header Rows             | First Row: Drive information including Drive Model, software version, control method, and sampling time<br>Second Row: Log data information including the monitor number, number decimal points, and unit code |

## ■ Log File Configuration

The [Log\_Files] folder is created in the root directory of the micro SD card. This is where the log data is stored as CSV files. Log data files are created in this configuration. The number of rows changes when the number of selected monitors change.

|            |                      |
|------------|----------------------|
| First row  | Drive information    |
| Second row | Log data information |
| Third row  | Log data 1           |
| :          | Log data 2           |
| :          | Log data 3           |





## 2.11 o: Keypad-Related Settings

### ■ o5-03: Log Monitor Data 1

| No.<br>(Hex.)          | Name               | Description   | Default<br>(Range)      |
|------------------------|--------------------|---|-------------------------|
| o5-03<br>(1553)<br>RUN | Log Monitor Data 1 | <b>V/f</b> <b>CL-V/f</b> <b>OLV</b> <b>CLV</b> <b>AOLV</b> <b>OLV/PM</b> <b>AOLV/PM</b> <b>CLV/PM</b> <b>EZOLV</b><br>Sets the data log monitor. This parameter is only available when using an LCD keypad. | 101<br>(000, 101 - 999) |

**Note:**

Sets the number of the *U* monitor you want to log.

For example, to show *U1-01* [Frequency Reference], set *o5-03* = 101. When it is not necessary to set data log monitors, set this parameter to 000. You cannot select *U2* monitor [Fault Trace] or *U3* Monitor [Fault History].

### ■ o5-04: Log Monitor Data 2

| No.<br>(Hex.)          | Name               | Description   | Default<br>(Range)      |
|------------------------|--------------------|---|-------------------------|
| o5-04<br>(1554)<br>RUN | Log Monitor Data 2 | <b>V/f</b> <b>CL-V/f</b> <b>OLV</b> <b>CLV</b> <b>AOLV</b> <b>OLV/PM</b> <b>AOLV/PM</b> <b>CLV/PM</b> <b>EZOLV</b><br>Sets the data log monitor. This parameter is only available when using an LCD keypad. | 102<br>(000, 101 - 999) |

**Note:**

Sets the number of the *U* monitor you want to log.

For example, to show *U1-02* [Output Frequency], set *o5-04* = 102. When it is not necessary to set data log monitors, set this parameter to 000. You cannot select *U2* monitor [Fault Trace] or *U3* Monitor [Fault History].

### ■ o5-05: Log Monitor Data 3

| No.<br>(Hex.)          | Name               | Description   | Default<br>(Range)      |
|------------------------|--------------------|---|-------------------------|
| o5-05<br>(1555)<br>RUN | Log Monitor Data 3 | <b>V/f</b> <b>CL-V/f</b> <b>OLV</b> <b>CLV</b> <b>AOLV</b> <b>OLV/PM</b> <b>AOLV/PM</b> <b>CLV/PM</b> <b>EZOLV</b><br>Sets the data log monitor. This parameter is only available when using an LCD keypad. | 103<br>(000, 101 - 999) |

**Note:**

Sets the number of the *U* monitor you want to log.

For example, to show *U1-03* [Output Current], set *o5-05* = 103. When it is not necessary to set data log monitors, set this parameter to 000. You cannot select *U2* monitor [Fault Trace] or *U3* Monitor [Fault History].

### ■ o5-06: Log Monitor Data 4

| No.<br>(Hex.)          | Name               | Description   | Default<br>(Range)      |
|------------------------|--------------------|---|-------------------------|
| o5-06<br>(1556)<br>RUN | Log Monitor Data 4 | <b>V/f</b> <b>CL-V/f</b> <b>OLV</b> <b>CLV</b> <b>AOLV</b> <b>OLV/PM</b> <b>AOLV/PM</b> <b>CLV/PM</b> <b>EZOLV</b><br>Sets the data log monitor. This parameter is only available when using an LCD keypad. | 107<br>(000, 101 - 999) |

**Note:**

Sets the number of the *U* monitor you want to log.

For example, to show *U1-07* [DC Bus Voltage], set *o5-06* = 107. When it is not necessary to set data log monitors, set this parameter to 000. You cannot select *U2* monitor [Fault Trace] or *U3* Monitor [Fault History].

### ■ o5-07: Log Monitor Data 5










| No.<br>(Hex.)          | Name               | Description   | Default<br>(Range)      |
|------------------------|--------------------|---|-------------------------|
| o5-07<br>(1557)<br>RUN | Log Monitor Data 5 | <b>V/f</b> <b>CL-V/f</b> <b>OLV</b> <b>CLV</b> <b>AOLV</b> <b>OLV/PM</b> <b>AOLV/PM</b> <b>CLV/PM</b> <b>EZOLV</b><br>Sets the data log monitor. This parameter is only available when using an LCD keypad. | 108<br>(000, 101 - 999) |

**Note:**

Sets the number of the *U* monitor you want to log.

For example, to show *U1-08* [Output Power], set *o5-07* = 108. When it is not necessary to set data log monitors, set this parameter to 000. You cannot select *U2* monitor [Fault Trace] or *U3* Monitor [Fault History].

### ■ o5-08: Log Monitor Data 6










| No. (Hex.)             | Name               | Description   | Default (Range)   |
|------------------------|--------------------|---|---|
| o5-08<br>(1558)<br>RUN | Log Monitor Data 6 |         <br>Sets the data log monitor. This parameter is only available when using an LCD keypad. | V/f, OLV/PM: 0, CL-V/f, OLV, CLV, AOLV, AOLV/PM, CLV/PM, EZOLV: 105<br>(000, 101 - 999) |

**Note:**

Sets the number of the *U* monitor you want to log.

For example, to show *U1-01* [Frequency Reference], set *o5-08* = 101. When it is not necessary to set data log monitors, set this parameter to 000. You cannot select *U2* monitor [Fault Trace] or *U3* Monitor [Fault History].

### ■ o5-09: Log Monitor Data 7










| No. (Hex.)             | Name               | Description   | Default (Range)         |
|------------------------|--------------------|---|-------------------------|
| o5-09<br>(1559)<br>RUN | Log Monitor Data 7 |         <br>Sets the data log monitor. This parameter is only available when using an LCD keypad. | 110<br>(000, 101 - 999) |

**Note:**

Sets the number of the *U* monitor you want to log.

For example, to show *U1-01* [Frequency Reference], set *o5-09* = 101. When it is not necessary to set data log monitors, set this parameter to 000. You cannot select *U2* monitor [Fault Trace] or *U3* Monitor [Fault History].

### ■ o5-10: Log Monitor Data 8










| No. (Hex.)             | Name               | Description   | Default (Range)         |
|------------------------|--------------------|---|-------------------------|
| o5-10<br>(155A)<br>RUN | Log Monitor Data 8 |         <br>Sets the data log monitor. This parameter is only available when using an LCD keypad. | 112<br>(000, 101 - 999) |

**Note:**

Sets the number of the *U* monitor you want to log.

For example, to show *U1-01* [Frequency Reference], set *o5-10* = 101. When it is not necessary to set data log monitors, set this parameter to 000. You cannot select *U2* monitor [Fault Trace] or *U3* Monitor [Fault History].

### ■ o5-11: Log Monitor Data 9










| No. (Hex.)             | Name               | Description   | Default (Range)         |
|------------------------|--------------------|---|-------------------------|
| o5-11<br>(155B)<br>RUN | Log Monitor Data 9 |         <br>Sets the data log monitor. This parameter is only available when using an LCD keypad. | 000<br>(000, 101 - 999) |

**Note:**

Sets the number of the *U* monitor you want to log.

For example, to show *U1-01* [Frequency Reference], set *o5-11* = 101. When it is not necessary to set data log monitors, set this parameter to 000. You cannot select *U2* monitor [Fault Trace] or *U3* Monitor [Fault History].

### ■ o5-12: Log Monitor Data 10

| No. (Hex.)             | Name                | Description   | Default (Range)         |
|------------------------|---------------------|---|-------------------------|
| o5-12<br>(155C)<br>RUN | Log Monitor Data 10 |         <br>Sets the data log monitor. This parameter is only available when using an LCD keypad. | 000<br>(000, 101 - 999) |

**Note:**

Sets the number of the *U* monitor you want to log.

For example, to show *U1-01* [Frequency Reference], set *o5-12* = 101. When it is not necessary to set data log monitors, set this parameter to 000. You cannot select *U2* monitor [Fault Trace] or *U3* Monitor [Fault History].

## 2.12 T: Auto-Tuning










Numbers identifying the *T parameters* are displayed when an LED keypad is used. The names of the parameters are displayed on the LCD screen of the LCD keypad. Set the following.

- Induction Motor Auto-Tuning
- PM Motor Auto-Tuning
- ASR and Inertia Tuning

### ◆ T0: Tuning Mode Selection

#### ■ T0-00: Tuning Mode Selection

When your control method supports Control Tuning, set *T0-00* first. Then, set *T1-00* [*Motor 1/Motor 2 Selection*] to select the motor you will tune. Then, set the tuning mode in *T2-01* [*PM Auto-Tuning Selection*] or *T3-00* [*Control Loop Tuning Selection*].

| No.<br>(Hex.)   | Name                  | Description   | Default<br>(Range) |
|-----------------|-----------------------|---|--------------------|
| T0-00<br>(1197) | Tuning Mode Selection |         <br>Sets the type of Auto-Tuning. | 0<br>(0, 1)        |

#### 0 : Motor Parameter Tuning

#### 1 : Control Tuning

##### Note:

The available tuning modes are different for different control methods.










### ◆ T1: Induction Motor Auto-Tuning

*T1 parameters* set the Auto-Tuning input data for induction motor tuning.

##### Note:

- The base frequency of drive dedicated motors and special motors for use with vector control may be lower than the base frequency of general-purpose motors, which is 50 Hz or 60 Hz. In such cases, this lower frequency is used as the value for *E1-06* [*Base Frequency*] and *E1-04* [*Maximum Output Frequency*] after Auto-Tuning completes. If the maximum output frequency is too low and causes problems, change the setting of *E1-04* after Auto-Tuning completes.
- The following induction motor parameters are set automatically.
  - E1-xx* [*V/f Pattern for Motor 1*]
  - E2-xx* [*Motor Parameters*]
  - E3-xx* [*V/f Pattern for Motor 2*]
  - E4-xx* [*Motor 2 Parameters*]
  - F1-xx* [*Encoder Options*] (only with Closed Loop Vector Control)

#### ■ T1-00: Motor 1/Motor 2 Selection

| No.<br>(Hex.)   | Name                      | Description   | Default<br>(Range) |
|-----------------|---------------------------|---|--------------------|
| T1-00<br>(0700) | Motor 1/Motor 2 Selection |         <br>Sets which motor to tune when motor 1/2 switching is enabled. | 1<br>(1, 2)        |

##### Note:

This parameter is available when *H1-xx* = 16 [*Motor 2 Selection*]. The keypad will not show this parameter when *H1-xx* ≠ 16.

#### 1 : Motor 1

Auto-Tuning automatically sets parameters *E1-xx* and *E2-xx* for motor 1.

#### 2 : Motor 2

Auto-Tuning automatically sets parameters *E3-xx* and *E4-xx* for motor 2. Make sure that you connect motor 2 to the drive for Auto-Tuning.



### ■ T1-01: Auto-Tuning Mode Selection

| No.<br>(Hex.)   | Name                  | Description   | Default<br>(Range)                           |
|-----------------|-----------------------|---|--|
| T1-01<br>(0701) | Tuning Mode Selection | <b>V/f</b> <b>CL-V/f</b> <b>OLV</b> <b>CLV</b> <b>AOLV</b> <b>OLV/PM</b> <b>AOLV/PM</b> <b>CLV/PM</b> <b>EZOLV</b><br>Sets the type of Auto-Tuning. | Determined by A1-02<br>(Determined by A1-02) |

**0 : Rotational Auto-Tuning**

**1 : Stationary Auto-Tuning 1**

**2 : Stationary Line-Line Resistance**

### ■ T1-02: Motor Rated Power

| No.<br>(Hex.)   | Name              | Description  | Default<br>(Range)                               |
|-----------------|-------------------|--|--|
| T1-02<br>(0702) | Motor Rated Power | <b>V/f</b> <b>CL-V/f</b> <b>OLV</b> <b>CLV</b> <b>AOLV</b> <b>OLV/PM</b> <b>AOLV/PM</b> <b>CLV/PM</b> <b>EZOLV</b><br>Sets the motor rated output power in the unit set by o1-58 [Motor Power Unit Selection]. | Determined by o2-04, C6-01<br>(0.00 – 650.00 kW) |

### ■ T1-03: Motor Rated Voltage

| No.<br>(Hex.)   | Name                | Description   | Default<br>(Range)  |
|-----------------|---------------------|---|---|
| T1-03<br>(0703) | Motor Rated Voltage | <b>V/f</b> <b>CL-V/f</b> <b>OLV</b> <b>CLV</b> <b>AOLV</b> <b>OLV/PM</b> <b>AOLV/PM</b> <b>CLV/PM</b> <b>EZOLV</b><br>Sets the rated voltage (V) of the motor. Enter the base speed voltage for constant output motors. | Determined by o2-04, C6-01<br>(200 V Class: 0.0 - 255.5 V,<br>400 V Class: 0.0 - 511.0 V) |

If you do Auto-Tuning on a drive-dedicated motor or a specialized motor for vector control, the voltage or frequency can be lower than that of a general-purpose motor. Always compare the data from the nameplate or test report with the Auto-Tuning results and check for differences. Enter the voltage necessary to operate the motor in no-load conditions at rated speed for better control precision around rated speed. If the motor test report or the motor nameplate is not available, enter approximately 90% of the motor rated voltage.

If the drive input power supply voltage is low, enter approximately 90% of the input voltage. When the input power supply voltage is low, the current will increase. Make sure that the main power supply capacity is correct and use a molded-case circuit breaker for the drive.

### ■ T1-04: Motor Rated Current

| No.<br>(Hex.)   | Name                | Description  | Default<br>(Range)  |
|-----------------|---------------------|--|---|
| T1-04<br>(0704) | Motor Rated Current | <b>V/f</b> <b>CL-V/f</b> <b>OLV</b> <b>CLV</b> <b>AOLV</b> <b>OLV/PM</b> <b>AOLV/PM</b> <b>CLV/PM</b> <b>EZOLV</b><br>Sets the rated current (A) of the motor. | Determined by o2-04<br>(10% to 200% of the drive rated current) |

Set the motor rated current between 50% and 100% of the drive rated current for the best performance. Enter the current at the motor base speed.

### ■ T1-05: Motor Base Frequency

| No.<br>(Hex.)   | Name                 | Description  | Default<br>(Range)          |
|-----------------|----------------------|--|-----------------------------|
| T1-05<br>(0705) | Motor Base Frequency | <b>V/f</b> <b>CL-V/f</b> <b>OLV</b> <b>CLV</b> <b>AOLV</b> <b>OLV/PM</b> <b>AOLV/PM</b> <b>CLV/PM</b> <b>EZOLV</b><br>Sets the base frequency (Hz) of the motor. | 60.0 Hz<br>(0.0 - 590.0 Hz) |

When Auto-Tuning is carried out, the value of T1-05 is set to E1-04 [Maximum Output Frequency]. If T1-05 < 40 Hz, E1-04 = 40 Hz. If you operate the drive at a speed that is higher than the base frequency, or if you operate in the field weakening range, set E1-04 (E3-04 for motor 2) to the maximum output frequency after you complete Auto-Tuning.

## 2.12 T: Auto-Tuning

### ■ T1-06: Number of Motor Poles

| No. (Hex.)      | Name                  | Description  | Default (Range) |
|-----------------|-----------------------|--|-----------------|
| T1-06<br>(0706) | Number of Motor Poles | <input type="checkbox"/> V/f <input type="checkbox"/> CL-V/f <input type="checkbox"/> OLV <input checked="" type="checkbox"/> CLV <input type="checkbox"/> AOLV <input type="checkbox"/> OLV/PM <input type="checkbox"/> AOLV/PM <input type="checkbox"/> CLV/PM <input type="checkbox"/> EZOLV<br>Sets the number of motor poles. | 4<br>(2 to 120) |

### ■ T1-07: Motor Base Speed

| No. (Hex.)      | Name             | Description   | Default (Range)   |
|-----------------|------------------|---|---|
| T1-07<br>(0707) | Motor Base Speed | <input type="checkbox"/> V/f <input type="checkbox"/> CL-V/f <input type="checkbox"/> OLV <input checked="" type="checkbox"/> CLV <input type="checkbox"/> AOLV <input type="checkbox"/> OLV/PM <input type="checkbox"/> AOLV/PM <input type="checkbox"/> CLV/PM <input type="checkbox"/> EZOLV<br>Sets the motor base speed for Auto-Tuning (min <sup>-1</sup> (r/min)). | 1750 min <sup>-1</sup> (r/min)<br>(0 - 35400 min <sup>-1</sup> (r/min)) |

### ■ T1-08: Encoder Pulse Count (PPR)

| No. (Hex.)      | Name                      | Description   | Default (Range)              |
|-----------------|---------------------------|---|------------------------------|
| T1-08<br>(0708) | Encoder Pulse Count (PPR) | <input type="checkbox"/> V/f <input type="checkbox"/> CL-V/f <input type="checkbox"/> OLV <input checked="" type="checkbox"/> CLV <input type="checkbox"/> AOLV <input type="checkbox"/> OLV/PM <input type="checkbox"/> AOLV/PM <input type="checkbox"/> CLV/PM <input type="checkbox"/> EZOLV<br>Sets the number of PG (pulse generator, encoder) pulses. | 1024 ppr<br>(0 - 60,000 ppr) |

Set the actual number of pulses for one full motor rotation.

### ■ T1-09: Motor No-Load Current

| No. (Hex.)      | Name                  | Description  | Default (Range)                   |
|-----------------|-----------------------|--|-----------------------------------|
| T1-09<br>(0709) | Motor No-Load Current | <input type="checkbox"/> V/f <input type="checkbox"/> CL-V/f <input checked="" type="checkbox"/> OLV <input checked="" type="checkbox"/> CLV <input type="checkbox"/> AOLV <input type="checkbox"/> OLV/PM <input type="checkbox"/> AOLV/PM <input type="checkbox"/> CLV/PM <input type="checkbox"/> EZOLV<br>Sets the no-load current of the motor. | -<br>(0A - T1-04; max. of 2999.9) |

**Note:**

- The display units are different for different models:
- 2004 to 2042, 4002 to 4023: 0.01 A
  - 2056 to 2415, 4031 to 4720: 0.1 A

The value shown is the no-load current that is automatically calculated from the values set in *T1-02 [Motor Rated Power]* and *T1-04 [Motor Rated Current]*. Set the no-load current shown on the motor test report. If the motor test report is not available, do not change this parameter.

### ■ T1-10: Motor Rated Slip Frequency

| No. (Hex.)      | Name                       | Description  | Default (Range)          |
|-----------------|----------------------------|--|--------------------------|
| T1-10<br>(070A) | Motor Rated Slip Frequency | <input type="checkbox"/> V/f <input type="checkbox"/> CL-V/f <input checked="" type="checkbox"/> OLV <input checked="" type="checkbox"/> CLV <input type="checkbox"/> AOLV <input type="checkbox"/> OLV/PM <input type="checkbox"/> AOLV/PM <input type="checkbox"/> CLV/PM <input type="checkbox"/> EZOLV<br>Sets motor rated slip. | -<br>(0.000 - 20.000 Hz) |

Shows 0.000 Hz as the default value. Set the rated slip shown on the motor test report. If the motor test report is not available, do not change this parameter.

### ■ T1-11: Motor Iron Loss

| No. (Hex.)      | Name            | Description  | Default (Range)                               |
|-----------------|-----------------|--|---|
| T1-11<br>(070B) | Motor Iron Loss | <input type="checkbox"/> V/f <input checked="" type="checkbox"/> CL-V/f <input type="checkbox"/> OLV <input type="checkbox"/> CLV <input type="checkbox"/> AOLV <input type="checkbox"/> OLV/PM <input type="checkbox"/> AOLV/PM <input type="checkbox"/> CLV/PM <input type="checkbox"/> EZOLV<br>Sets the iron loss for calculating the energy-saving coefficient. | Determined by E2-11 or E4-11<br>(0 - 65535 W) |

**Note:**

The default setting is different for different motor codes and motor parameter settings.

The value shown is the *E2-10 [Motor Iron Loss]* or *E4-10 [Motor 2 Iron Loss]* for the motor output set in *T1-02 [Motor Rated Power]*. If the motor test report is available, enter the motor iron loss value to *T1-11*.

### ■ T1-12: Test Mode Selection

| No. (Hex.)   | Name                | Description  | Default (Range) |
|--------------|---------------------|--|-----------------|
| T1-12 (0BDB) | Test Mode Selection | <div style="display: flex; justify-content: space-between; font-size: 0.8em;"> <span>V/f</span> <span>CL-V/f</span> <span>OLV</span> <span>CLV</span> <span>AOLV</span> <span>OLV/PM</span> <span>AOLV/PM</span> <span>CLV/PM</span> <span>EZOLV</span> </div> <p>Sets the function to enable Test Mode after Stationary Auto-Tuning. When you can operate the motor with a light load attached after Stationary Auto-Tuning is complete, enable this parameter.</p> | 0<br>(0, 1)     |

**0 : No**

**1 : Yes**

After Auto-Tuning, the drive automatically sets *E2-02 [Motor Rated Slip]* and *E2-03 [Motor No-Load Current]* when you operate the motor for the first time in Drive Mode.

**Note:**

After Auto-Tuning is complete and you set the drive to Drive Mode, operate the motor in these conditions:

- Make sure that you connect all wiring between the drive and motor
- Make sure that a mechanical brake on the motor shaft is not locked
- Keep the motor-load ratio at 30%
- Hold constant speed for longer than 1 second at a minimum of 30% of the speed set in *E1-06 [Base Frequency]* (the default setting is the same as the maximum frequency).

### ■ T1-13: No-load voltage

| No. (Hex.)   | Name            | Description   | Default (Range)  |
|--------------|-----------------|---|--|
| T1-13 (0BDC) | No-load voltage | <div style="display: flex; justify-content: space-between; font-size: 0.8em;"> <span>V/f</span> <span>CL-V/f</span> <span>OLV</span> <span>CLV</span> <span>AOLV</span> <span>OLV/PM</span> <span>AOLV/PM</span> <span>CLV/PM</span> <span>EZOLV</span> </div> <p>Sets the no-load voltage of the motor. If you know the no-load voltage at the rated speed in a test report, set that voltage value. If you do not know the no-load voltage, do not change from the initial value.</p> | T1-03 × E1-21<br>(200 V Class: 0.0 - 255.0 V,<br>400 V Class: 0.0 - 510.0 V) |

**Note:**

- To get the same qualities as a Yaskawa 1000-series drive or previous models, set this parameter = *T1-03 [Motor Rated Voltage]* value.
- The default value is different for different models.
  - 2004 - 2006, 4002 - 4004: T1-03 × 0.85
  - 20 10 - 2415, 4005 - 4250: T1-03 × 0.90
  - 4296- 4720: T1-03 × 0.95

## ◆ T2: PM Motor Auto-Tuning

*T2 parameters* set the Auto-Tuning input data for PM motor tuning.

**Note:**

The drive automatically sets these PM motor parameters:

- E1-xx [V/f Pattern for Motor 1]
- E5-xx [V/f Pattern for Motor 1]
- F1-xx [Encoder Option Setup]  
Only when *A1-02 = 7 [Control Method Selection = PM Closed Loop Vector]*

### ■ T2-01: PM Auto-Tuning Selection

| No. (Hex.)   | Name                     | Description   | Default (Range)            |
|--------------|--------------------------|---|----------------------------|
| T2-01 (0750) | PM Auto-Tuning Selection | <div style="display: flex; justify-content: space-between; font-size: 0.8em;"> <span>V/f</span> <span>CL-V/f</span> <span>OLV</span> <span>CLV</span> <span>AOLV</span> <span>OLV/PM</span> <span>AOLV/PM</span> <span>CLV/PM</span> <span>EZOLV</span> </div> <p>Sets the type of Auto-Tuning for PM motors.</p> | 0<br>(Determined by A1-02) |

**Note:**

Yaskawa recommends Rotational (Ld, Lq, R, back-EMF) for specialized motors. Rotational Auto-Tuning rotates the motor to measure the actual induction voltage constants for more accurate control than Stationary Auto-Tuning.

**0 : PM Motor Parameter Settings**

**1 : Stationary (Ld, Lq, R)**

**2 : PM StaTun for Stator Resistance**

**3 : Z-Pulse Offset (Pole Position)**

**4 : PM Rotational Auto-Tuning****5 : High Frequency Injection Auto-Tuning****■ T2-02: PM Motor Code Selection**

| No.<br>(Hex.)   | Name                    | Description   | Default<br>(Range)    |
|-----------------|-------------------------|---|-----------------------|
| T2-02<br>(0751) | PM Motor Code Selection | V/f CL-V/f OLV CLV AOLV <b>OLV/PM</b> AOLV/PM CLV/PM EZOLV<br>If the drive is operating a Yaskawa PM motor from the SMRA, SSR1, or SST4 series, enter the PM motor code in accordance with the rotation speed and motor output. | FFFF<br>(0000 - FFFF) |

Enter the motor code in *T2-02* to automatically set parameters *T2-03* to *T2-14*. When you are operating a specialized motor or a non-Yaskawa motor designed, set *T2-02* = *FFFF* and enter the data from the motor nameplate or the motor test report.

You can only enter the permitted PM motor codes. Different drive control methods will accept different PM motor codes.

**■ T2-03: PM Motor Type**

| No.<br>(Hex.)   | Name          | Description   | Default<br>(Range) |
|-----------------|---------------|---|--------------------|
| T2-03<br>(0752) | PM Motor Type | V/f CL-V/f OLV CLV AOLV <b>OLV/PM</b> AOLV/PM CLV/PM EZOLV<br>Sets the type of PM motor the drive will operate. | 1<br>(0, 1)        |

**0 : IPM motor****1 : SPM motor****■ T2-04: PM Motor Rated Power**

| No.<br>(Hex.)   | Name                 | Description  | Default<br>(Range)  |
|-----------------|----------------------|--|---|
| T2-04<br>(0730) | PM Motor Rated Power | V/f CL-V/f OLV CLV AOLV <b>OLV/PM</b> AOLV/PM CLV/PM EZOLV<br>Sets the PM motor rated output power in the unit set by <i>o1-58</i> [Motor Power Unit Selection]. | Determined by <i>o2-04</i> , <i>C6-01</i><br>(0.00 - 650.00 kW) |

**■ T2-05: PM Motor Rated Voltage**

| No.<br>(Hex.)   | Name                   | Description  | Default<br>(Range)   |
|-----------------|------------------------|--|--|
| T2-05<br>(0732) | PM Motor Rated Voltage | V/f CL-V/f OLV CLV AOLV <b>OLV/PM</b> AOLV/PM CLV/PM EZOLV<br>Sets the rated voltage (V) of the motor. | 200 V Class: 230.0 V, 400 V:<br>460.0 V<br>(200 V Class: 0.0 - 255.0 V,<br>400 V Class: 0.0 - 510.0 V) |

**■ T2-06: PM Motor Rated Current**

| No.<br>(Hex.)   | Name                   | Description  | Default<br>(Range)  |
|-----------------|------------------------|--|---|
| T2-06<br>(0733) | PM Motor Rated Current | V/f CL-V/f OLV CLV AOLV <b>OLV/PM</b> AOLV/PM CLV/PM EZOLV<br>Sets the rated current (A) of the motor. | Determined by <i>o2-04</i><br>(10% to 200% of the drive<br>rated current) |

**■ T2-07: PM Motor Base Frequency**

| No.<br>(Hex.)   | Name                    | Description  | Default<br>(Range)          |
|-----------------|-------------------------|--|-----------------------------|
| T2-07<br>(0753) | PM Motor Base Frequency | V/f CL-V/f OLV CLV AOLV <b>OLV/PM</b> AOLV/PM CLV/PM EZOLV<br>Sets the base frequency (Hz) of the motor. | 60.0 Hz<br>(0.0 - 590.0 Hz) |

### ■ T2-08: Number of PM Motor Poles

| No. (Hex.)      | Name                     | Description   | Default (Range) |
|-----------------|--------------------------|---|-----------------|
| T2-08<br>(0734) | Number of PM Motor Poles | V/f CL-V/f OLV CLV AOLV <b>OLV/PM</b> AOLV/PM CLV/PM EZOLV<br>Sets the number of motor poles. | 4<br>(2 - 48)   |

### ■ T2-09: PM Motor Base Speed

| No. (Hex.)      | Name                | Description   | Default (Range)   |
|-----------------|---------------------|---|---|
| T2-09<br>(0731) | PM Motor Base Speed | V/f CL-V/f OLV CLV AOLV <b>OLV/PM</b> AOLV/PM CLV/PM EZOLV<br>Sets the motor base speed ( $\text{min}^{-1}$ (r/min)). | 1750 $\text{min}^{-1}$ (r/min)<br>(0 - 34500 $\text{min}^{-1}$ (r/min)) |

### ■ T2-10: PM Motor Stator Resistance

| No. (Hex.)      | Name                       | Description  | Default (Range)                                   |
|-----------------|----------------------------|--|---|
| T2-10<br>(0754) | PM Motor Stator Resistance | V/f CL-V/f OLV CLV AOLV <b>OLV/PM</b> AOLV/PM CLV/PM EZOLV<br>Sets the stator resistance for each motor phase. | Determined by T2-02<br>(0.000 - 65.000 $\Omega$ ) |

**Note:**

This parameter does not set line-to-line resistance.

### ■ T2-11: PM Motor d-Axis Inductance

| No. (Hex.)      | Name                       | Description   | Default (Range)                           |
|-----------------|----------------------------|---|---|
| T2-11<br>(0735) | PM Motor d-Axis Inductance | V/f CL-V/f OLV CLV AOLV <b>OLV/PM</b> AOLV/PM CLV/PM EZOLV<br>Sets the d-axis inductance of the motor on a per phase basis. | Determined by T2-02<br>(0.00 - 600.00 mH) |

### ■ T2-12: PM Motor q-Axis Inductance

| No. (Hex.)      | Name                       | Description   | Default (Range)                           |
|-----------------|----------------------------|---|---|
| T2-12<br>(0736) | PM Motor q-Axis Inductance | V/f CL-V/f OLV CLV AOLV <b>OLV/PM</b> AOLV/PM CLV/PM EZOLV<br>Sets the q-Axis inductance of the motor on a per phase basis. | Determined by T2-02<br>(0.00 - 600.00 mH) |

### ■ T2-13: Back-EMF Units Selection

| No. (Hex.)      | Name                     | Description   | Default (Range) |
|-----------------|--------------------------|---|-----------------|
| T2-13<br>(0755) | Back-EMF Units Selection | V/f CL-V/f OLV CLV AOLV <b>OLV/PM</b> AOLV/PM CLV/PM EZOLV<br>Sets the units that the drive uses to set the induced voltage constant. | 0<br>(0, 1)     |

**0** : mV/(rev/min)

**1** : mV/(rad/s)

**Note:**

- When  $T2-13 = 0$ , the drive will use  $E5-24$  [PM Back-EMF L-L  $V_{rms}$  (mV/rpm)] and will automatically set  $E5-09$  [PM Back-EMF  $V_{peak}$  (mV/(rad/s))] = 0.0.
- When  $T2-13 = 1$ , the drive will use  $E5-09$  and will automatically set  $E5-24 = 0.0$ .

### ■ T2-14: Back-EMF Voltage Constant (Ke)

| No. (Hex.)      | Name                           | Description   | Default (Range)                       |
|-----------------|--------------------------------|---|---------------------------------------|
| T2-14<br>(0737) | Back-EMF Voltage Constant (Ke) | V/f CL-V/f OLV CLV AOLV <b>OLV/PM</b> AOLV/PM CLV/PM EZOLV<br>Sets the motor induced voltage constant (Ke). | Determined by T2-13<br>(0.0 - 2000.0) |

## 2.12 T: Auto-Tuning

### ■ T2-15: Pull-In Current Level

| No. (Hex.)      | Name                  | Description  | Default (Range)   |
|-----------------|-----------------------|--|-------------------|
| T2-15<br>(0756) | Pull-In Current Level | V/f CL-V/f OLV CLV AOLV <b>OLV/PM</b> AOLV/PM CLV/PM EZOLV<br>Sets the level of the pull-in current as a percentage of E5-03 [PM Motor Rated Current (FLA)]. Usually it is not necessary to change this setting. | 30%<br>(0 - 120%) |

If the load inertia is high, increase the setting value.

### ■ T2-16: Encoder Pulse Count (PPR)

| No. (Hex.)      | Name                      | Description  | Default (Range)             |
|-----------------|---------------------------|--|-----------------------------|
| T2-16<br>(0738) | Encoder Pulse Count (PPR) | V/f CL-V/f OLV CLV AOLV OLV/PM AOLV/PM <b>CLV/PM</b> EZOLV<br>Sets the number of PG (pulse generator, encoder) pulses. | 1024 ppr<br>(1 - 15000 ppr) |

Set the actual number of pulses for one full motor rotation.

### ■ T2-17: Encoder Z-Pulse Offset

| No. (Hex.)      | Name                   | Description  | Default (Range)            |
|-----------------|------------------------|--|----------------------------|
| T2-17<br>(0757) | Encoder Z-Pulse Offset | V/f CL-V/f OLV CLV AOLV OLV/PM AOLV/PM <b>CLV/PM</b> EZOLV<br>Sets the encoder Z-pulse offset ( $\Delta\theta$ ) (pulse generator, encoder) that is listed on the motor nameplate. | 0.0°<br>(-180.0 - +180.0°) |

If you do not know the quantity of encoder (pulse generator, encoder) Z-pulse offset, or if you replaced the encoder, do Z Pulse Offset Tuning and correct for the offset ( $\Delta\theta$ ) from the Z phase.

## ◆ T3: ASR and Inertia Tuning

### ■ T3-00: Control Loop Tuning Selection

| No. (Hex.)      | Name                          | Description   | Default (Range) |
|-----------------|-------------------------------|---|-----------------|
| T3-00<br>(1198) | Control Loop Tuning Selection | V/f CL-V/f OLV <b>CLV</b> AOLV OLV/PM AOLV/PM CLV/PM EZOLV<br>Sets the type of Control Auto-Tuning. | 0<br>(0 - 3)    |

0 : Inertia Tuning

1 : ASR (Speed Regulator)

2 : Deceleration Rate Tuning

3 : KEB Tuning

Note:

Settings 0 and 1 are available only when A1-02 = 3, 7 [Control Method Selection = CLV, CLV/PM].

### ■ T3-01: Test Signal Frequency

| No. (Hex.)      | Name                  | Description   | Default (Range)           |
|-----------------|-----------------------|---|---------------------------|
| T3-01<br>(0760) | Test Signal Frequency | V/f CL-V/f OLV <b>CLV</b> AOLV OLV/PM AOLV/PM CLV/PM EZOLV<br>Sets the frequency of the test signal applied to the motor during Inertia Tuning. Usually it is not necessary to change this setting. | 3.0 Hz<br>(0.1 - 20.0 Hz) |

If the load inertia is too large and the drive detects a fault after Inertia Tuning, decrease the setting.

### ■ T3-02: Test Signal Amplitude

| No. (Hex.)      | Name                  | Description   | Default (Range)             |
|-----------------|-----------------------|---|-----------------------------|
| T3-02<br>(0761) | Test Signal Amplitude | V/f CL-V/f OLV <b>CLV</b> AOLV OLV/PM AOLV/PM CLV/PM EZOLV<br>Sets the amplitude of the test signal applied to the motor during Inertia Tuning. Usually it is not necessary to change this setting. | 0.5 rad<br>(0.1 - 10.0 rad) |

If the load inertia is too large and the drive detects a fault after Inertia Tuning, decrease the setting. If the drive detects a fault when *T3-01 [Test Signal Frequency]* is set to a low value, adjust this parameter.

### ■ T3-03: Motor Inertia

| No. (Hex.)      | Name          | Description  | Default (Range)  |
|-----------------|---------------|--|--|
| T3-03<br>(0762) | Motor Inertia | <div style="display: flex; justify-content: space-between; font-size: 0.8em;"> <span>V/f</span> <span>CL-V/f</span> <span>OLV</span> <span style="background-color: #333; color: white; padding: 2px;">CLV</span> <span>AOLV</span> <span>OLV/PM</span> <span>AOLV/PM</span> <span style="background-color: #333; color: white; padding: 2px;">CLV/PM</span> <span>EZOLV</span> </div> <p>Sets the inertia of the motor. This value uses the test signal response to calculate the load inertia.</p> | Determined by o2-04, C6-01, and E5-01<br>(0.0001 - 600.00 kgm <sup>2</sup> ) |

The default setting is for a Yaskawa standard motor as shown in the motor inertia table. Actual values will be different when you use induction motors or PM motors.

#### Note:

- The display units for the default setting and setting range are different for different models:
- 0.0001 kgm<sup>2</sup> units (setting range: 0.0001 kgm<sup>2</sup> to 6.0000 kgm<sup>2</sup>): 2004 to 2021, 4002 to 4012
  - 0.001 kgm<sup>2</sup> units (setting range: 0.001 kgm<sup>2</sup> to 60.000 kgm<sup>2</sup>): 2030 to 2211, 4018 to 4103
  - 0.01 kgm<sup>2</sup> units (setting range: 0.01 kgm<sup>2</sup> to 600.00 kgm<sup>2</sup>): 2257 to 2415, 4140 to 4720

### ■ T3-04: System Response Frequency

| No. (Hex.)      | Name                      | Description   | Default (Range)            |
|-----------------|---------------------------|---|----------------------------|
| T3-04<br>(0763) | System Response Frequency | <div style="display: flex; justify-content: space-between; font-size: 0.8em;"> <span>V/f</span> <span>CL-V/f</span> <span>OLV</span> <span style="background-color: #333; color: white; padding: 2px;">CLV</span> <span>AOLV</span> <span>OLV/PM</span> <span>AOLV/PM</span> <span style="background-color: #333; color: white; padding: 2px;">CLV/PM</span> <span>EZOLV</span> </div> <p>This parameter uses the load inertia value from the Inertia Tuning process to automatically calculate and set <i>C5-01 [ASR Proportional Gain 1]</i>.</p> | 10.0 Hz<br>(0.1 - 50.0 Hz) |

If this input value is too high, it can cause oscillation.

### ◆ T4: EZ Tuning

Use *T4 parameters* to input the data necessary for motor parameter Auto-Tuning when *A1-02 = 8 [Control Method Selection = EZ Vector Control]*. These two modes are available:

| T4-01 Setting | Operational overview  | Items input for tuning  | Items tuned  |
|---------------|---|---|--|
| 0             | Follow the instructions in the setup wizard on the keypad to manually enter the necessary motor parameters. | <ul style="list-style-type: none"> <li>• T4-02 [Motor Type Selection]</li> <li>• T4-03 [Motor Max Revolutions]</li> <li>• T4-04 [Motor Rated Revolutions]</li> <li>• T4-05 [Motor Rated Frequency] <sup>*1</sup></li> <li>• T4-06 [Motor Rated Voltage]</li> <li>• T4-07 [Motor Rated Current]</li> <li>• T4-08 [Motor Rated Capacity]</li> <li>• T4-09 [Motor Pole Count]</li> </ul> | <ul style="list-style-type: none"> <li>• E9-01 [Motor Type Selection]</li> <li>• E9-02 [Maximum Speed]</li> <li>• E9-03 [Rated Speed]</li> <li>• E9-04 [Base Frequency]</li> <li>• E9-05 [Base Voltage]</li> <li>• E9-06 [Motor Rated Current (FLA)]</li> <li>• E9-07 [Motor Rated Power (kW)]</li> <li>• E9-08 [Motor Pole Count]</li> <li>• E9-09 [Motor Rated Slip]</li> <li>• E9-10 [Motor Line-to-Line Resistance]</li> </ul> |
| 1             | Do only line-to-line resistance tuning.   | Motor Rated Current   | E9-10 [Motor Line-to-Line Resistance]  |

\*1 When you use a PM motor or a synchronous reluctance motor, it is not necessary to enter the rated frequency. The drive will use the rated rotation speed and number of motor poles to automatically calculate the rated frequency.

### ■ T4-01: EZ Tuning Mode Selection

| No. (Hex.)      | Name                     | Description   | Default (Range) |
|-----------------|--------------------------|---|-----------------|
| T4-01<br>(3130) | EZ Tuning Mode Selection | <div style="display: flex; justify-content: space-between; font-size: 0.8em;"> <span>V/f</span> <span>CL-V/f</span> <span>OLV</span> <span>CLV</span> <span>AOLV</span> <span>OLV/PM</span> <span>AOLV/PM</span> <span>CLV/PM</span> <span style="background-color: #333; color: white; padding: 2px;">EZOLV</span> </div> <p>Sets the type of Auto-Tuning for EZOLV control.</p> | 0<br>(0, 1)     |

#### 0 : Motor Parameter Setting

#### 1 : Line-to-Line Resistance

## 2.12 T: Auto-Tuning

### ■ T4-02: Motor Type Selection

| No. (Hex.)      | Name                 | Description   | Default (Range) |
|-----------------|----------------------|---|-----------------|
| T4-02<br>(3131) | Motor Type Selection | V/f CL-V/f OLV CLV AOLV OLV/PM AOLV/PM CLV/PM <b>EZOLV</b><br>Sets the type of motor. | 0<br>(0, 1, 2)  |

0 : Induction (IM)

1 : Permanent Magnet (PM)

2 : Synchronous Reluctance (SynRM)

### ■ T4-04: Motor Rated Revolutions

| No. (Hex.)      | Name                    | Description   | Default (Range)   |
|-----------------|-------------------------|---|---|
| T4-04<br>(3133) | Motor Rated Revolutions | V/f CL-V/f OLV CLV AOLV OLV/PM AOLV/PM CLV/PM <b>EZOLV</b><br>Sets rated rotation speed ( $\text{min}^{-1}$ ) of the motor. | -<br>((40 Hz to 120 Hz) $\times$ 60 $\times$ 2/<br>E9-08) |

### ■ T4-05: Motor Rated Frequency

| No. (Hex.)      | Name                  | Description   | Default (Range)                                       |
|-----------------|-----------------------|---|---|
| T4-05<br>(3134) | Motor Rated Frequency | V/f CL-V/f OLV CLV AOLV OLV/PM AOLV/PM CLV/PM <b>EZOLV</b><br>Sets the rated frequency (Hz) of the motor. | Determined by E9-01 and<br>o2-04<br>(40.0 - 120.0 Hz) |

**Note:**

When  $T4-02 = 1, 2$  [Motor Type Selection = PM, SynRM], input is not necessary because it assumes: Motor Rated Revolutions/60  $\times$  Number of Motor Poles/2.

### ■ T4-06: Motor Rated Voltage

| No. (Hex.)      | Name                | Description  | Default (Range)   |
|-----------------|---------------------|--|---|
| T4-06<br>(3135) | Motor Rated Voltage | V/f CL-V/f OLV CLV AOLV OLV/PM AOLV/PM CLV/PM <b>EZOLV</b><br>Sets the rated voltage (V) of the motor. | 200 V Class: 230.0 V, 400 V:<br>460.0 V<br>(200 V Class: 0.0 - 255.0<br>V, 400 V Class: 0.0 - 510.0<br>V) |

### ■ T4-07: Motor Rated Current

| No. (Hex.)      | Name                         | Description  | Default (Range)   |
|-----------------|------------------------------|--|---|
| T4-07<br>(3136) | PM Motor Rated Current (FLA) | V/f CL-V/f OLV CLV AOLV OLV/PM AOLV/PM CLV/PM <b>EZOLV</b><br>Sets the rated current (A) of the motor. | Determined by o2-04, C6-01<br>(10% to 200% of the drive<br>rated current) |

**Note:**

The value set here becomes the base value for motor protection, the torque limit, and torque control.

### ■ T4-08: Motor Rated Capacity

| No. (Hex.)      | Name                      | Description   | Default (Range)                           |
|-----------------|---------------------------|---|---|
| T4-08<br>(3137) | PM Motor Rated Power (kW) | V/f CL-V/f OLV CLV AOLV OLV/PM AOLV/PM CLV/PM <b>EZOLV</b><br>Sets the motor rated power in the unit set by o1-58 [Motor Power Unit Selection]. | Determined by E9-10<br>(0.10 - 650.00 kW) |

### ■ T4-09: Number of Poles

| No. (Hex.)      | Name                  | Description   | Default (Range)                 |
|-----------------|-----------------------|---|---------------------------------|
| T4-09<br>(3138) | Number of Motor Poles | V/f CL-V/f OLV CLV AOLV OLV/PM AOLV/PM CLV/PM <b>EZOLV</b><br>Sets the number of motor poles. | Determined by E9-01<br>(2 - 48) |



## Keypad Use and Test Run

---

|     |   |     |
|-----|---|-----|
| 3.1 | Section Safety .....  | 550 |
| 3.2 | Keypad: Names and Functions.....                                | 551 |
| 3.3 | LED Status Ring.....  | 557 |
| 3.4 | Keypad Operation .....  | 559 |
| 3.5 | Auto-Tuning .....   | 597 |
| 3.6 | Test Run .....  | 606 |
| 3.7 | Fine Tuning during Test Runs (Adjust the Control Function)..... | 608 |
| 3.8 | Test Run Checklist .....  | 615 |

## 3.1 Section Safety

### DANGER

#### Electrical Shock Hazard

**Do not examine, connect, or disconnect wiring on an energized drive. Before servicing, disconnect all power to the equipment and wait for the time specified on the warning label at a minimum. The internal capacitor stays charged after the drive is de-energized. The charge indicator LED extinguishes when the DC bus voltage decreases below 50 Vdc. When all indicators are OFF, remove the covers before measuring for dangerous voltages to make sure that the drive is safe.**

If you do work on the drive when it is energized, it will cause serious injury or death from electrical shock. The drive has internal capacitors that stay charged after you de-energize the drive.

### WARNING

#### Electrical Shock Hazard

**Do not operate the drive when covers are missing. Replace covers and shields before you operate the drive. Use the drive only as specified by the instructions.**

Some figures in this section include drives without covers or safety shields to more clearly show the inside of the drive. If covers or safety shields are missing from the drive, it can cause serious injury or death.

**Do not remove covers or touch circuit boards while the drive is energized.**

If you touch the internal components of an energized drive, it can cause serious injury or death.

#### Sudden Movement Hazard

**When you use a mechanical holding brake with the drive in a lifting application, you must close the brake if an input terminal triggers the Baseblock command to stop drive output.**

If you enter the baseblock command, the motor will suddenly coast and the load will slip, which can cause serious injury or death.

**When you use the drive in a lifting application, you must also install external safety circuitry. The drive does not have protection against accidental load drops in lifting applications. Install electrical and/or mechanical safety circuit mechanisms that are isolated from the drive circuitry.**

If you do not use external safety circuitry, the drive could drop the load and cause serious injury or death.

## 3.2 Keypad: Names and Functions

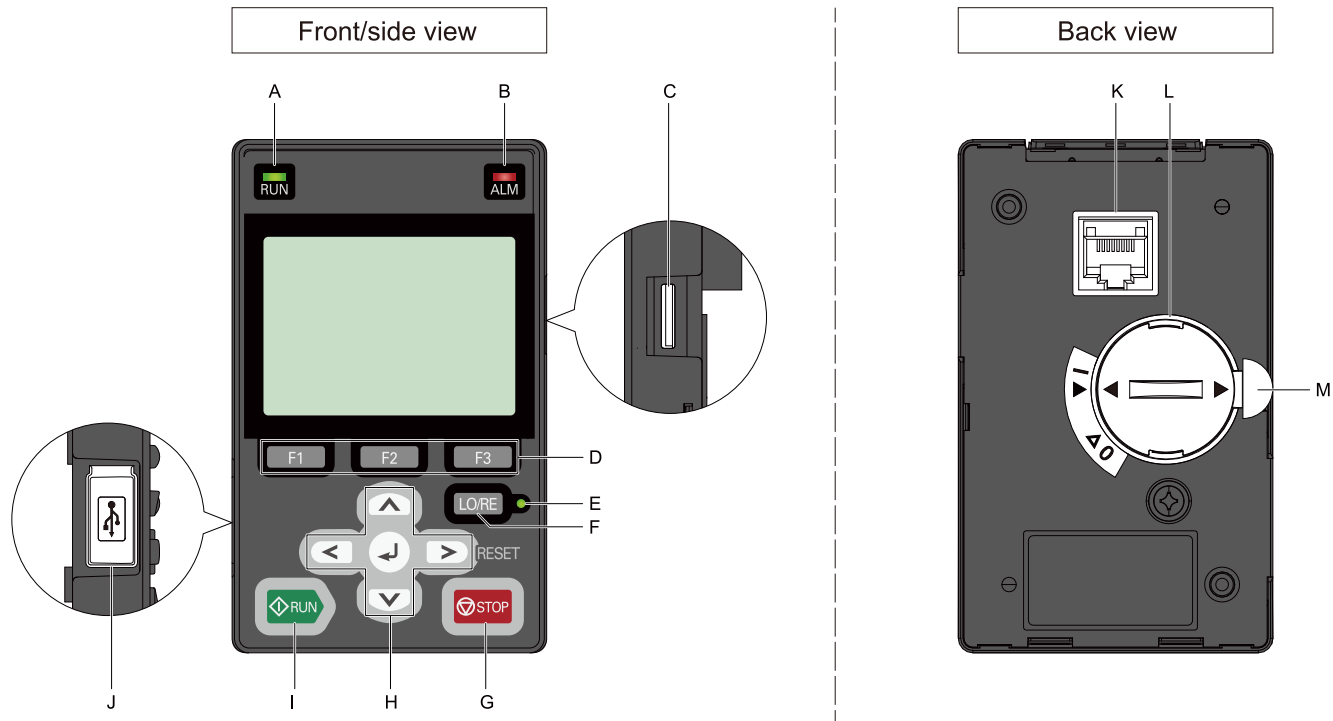


















Figure 3.1 Keypad

Table 3.1 Keypad: Names and Functions

| No. | Name   | Function   |
|-----|--|--|
| A   | RUN LED<br>                       | Illuminates to show that the drive is operating the motor.<br>The LED turns OFF when the drive stops.<br>Flashes to show that: <ul style="list-style-type: none"> <li>The drive is decelerating to stop.</li> <li>The drive received a Run command but the frequency reference is 0 Hz.</li> </ul> Flashes quickly to show that: <ul style="list-style-type: none"> <li>The drive received a Run command from the Multi-Function Digital Input (MFDI) terminals and is switching to REMOTE Mode while the drive is in LOCAL Mode.</li> <li>The drive received a Run command from the MFDI terminals when the drive is not in Drive Mode.</li> <li>The drive received a Fast Stop command.</li> <li>The safety function shuts off the drive output.</li> </ul> <ul style="list-style-type: none"> <li>The user pushed  on the keypad while the drive is operating in REMOTE Mode.</li> <li>The drive is energized with an active Run command and <math>b1-17 = 0</math> [Run Command at Power Up = Disregard Existing RUN Command].</li> </ul> |
| B   | ALM LED<br>                       | Illuminates when the drive detects a fault.<br>Flashes when the drive detects: <ul style="list-style-type: none"> <li>Alarm</li> <li>An oPE parameter setting error</li> <li>A fault or alarm during Auto-Tuning</li> </ul> The light switches off when the drive is in normal operation. There is no fault or alarm.  |
| C   | microSD Card Insertion Slot  | The insertion point for a microSD card.  |
| D   | Function Keys<br>(F1, F2, F3)<br> | The menu shown on the keypad sets the functions for function keys.<br>The name of each function is in the lower half of the display window.  |
| E   | LO/RE LED<br>                     | Illuminated: The keypad controls the Run command (LOCAL Mode).<br>OFF: The control circuit terminal or serial transmission device controls the Run command (REMOTE Mode).<br><b>Note:</b> <ul style="list-style-type: none"> <li>LOCAL: Operated using the keypad. Use the keypad to enter Run/Stop commands and the frequency reference command.</li> <li>REMOTE: Operated from the control circuit terminal or serial transmission. Use the frequency reference source entered in <math>b1-01</math> and the Run command source selected in <math>b1-02</math>.</li> </ul>   |

Keypad Use and Test

### 3.2 Keypad: Names and Functions

| No. | Name   | Function  |
|-----|--|---|
| F   | LO/RE Selection Key<br>         | Switches drive control for the Run command and frequency reference between the keypad (LOCAL) and an external source (REMOTE).<br><b>Note:</b><br><ul style="list-style-type: none"> <li>Stop operation to enable the LO/RE Selection Key when in Drive Mode. Set <math>o2-01 = 0</math> [<i>LO/RE Key Function Selection = Disabled</i>] to disable  when switching from REMOTE to LOCAL will have a negative effect on system performance.</li> <li>The drive will not switch between LOCAL and REMOTE when it is receiving a Run command from an external source.</li> </ul>  |
| G   | STOP Key<br>                    | Stops drive operation.<br><b>Note:</b><br>The STOP key has highest priority. Push  to stop the motor even when a Run command (REMOTE Mode) is active at any external Run command source. Set $o2-02 = 0$ [ <i>STOP Key Function Selection = Disabled</i> ] to disable the priority in  .  |
| H   | Left Arrow Key<br>              | Moves the cursor to the left.   |
|     | Up Arrow Key/Down Arrow Key<br> | <ul style="list-style-type: none"> <li>Scrolls up or down to display the next item or the previous item.</li> <li>Selects parameter numbers, and increments or decrements setting values.</li> </ul>  |
|     | Right Arrow Key (RESET)<br>     | <ul style="list-style-type: none"> <li>Moves the cursor to the right.</li> <li>Continues to the next screen.</li> <li>Clears drive faults.</li> </ul>   |
|     | ENTER Key<br>                   | <ul style="list-style-type: none"> <li>Enters parameter values and settings.</li> <li>Selects menu items to move the user between keypad displays.</li> <li>Selects each mode, parameter, and set value.</li> </ul>   |
| I   | RUN Key<br>                    | Starts the drive in LOCAL mode.<br>Starts the motor tuning procedure in Auto-Tuning Mode.<br><b>Note:</b><br>Push  on the keypad to set the drive to LOCAL Mode before using the keypad to operate the motor.  |
| J   | USB Terminal   | Insertion point for a mini USB cable. Uses a USB cable (USB standard 2.0, type A - mini-B) to connect the keypad to a PC.   |
| K   | RJ-45 Connector  | Connects to the drive using an RJ-45 8-pin straight through UTP CAT5e extension cable or keypad connector.  |
| L   | Clock Battery Cover  | Cover for the clock battery.<br><b>Note:</b><br><ul style="list-style-type: none"> <li>The battery included with the keypad is for operation check. It may be exhausted earlier than the expected battery life described in the manual.</li> <li>Refer to "Maintenance &amp; Troubleshooting Manual (TOEPAIGA8001)" for details on replacement procedure.</li> </ul> To replace the battery, use a Hitachi Maxell "CR2016 Lithium Manganese Dioxide Lithium Battery" or an equivalent battery with these properties: <ul style="list-style-type: none"> <li>Nominal voltage: 3 V</li> <li>Operating temperature range: -20°C to +85°C (-4°F to +185°F)</li> </ul> |
| M   | Insulation Sheet   | An insulating sheet is attached to the keypad battery to prevent battery drain. Remove the insulation sheet before you use the keypad for the first time.   |

**WARNING! Sudden Movement Hazard.** If you change the control source when  $b1-07 = 1$  [*LOCAL/REMOTE Run Selection = Accept Existing RUN Command*], the drive can start suddenly. Before you change the control source, remove all personnel from the area around the drive, motor, and load. Sudden starts can cause serious injury or death.

◆ LCD Display

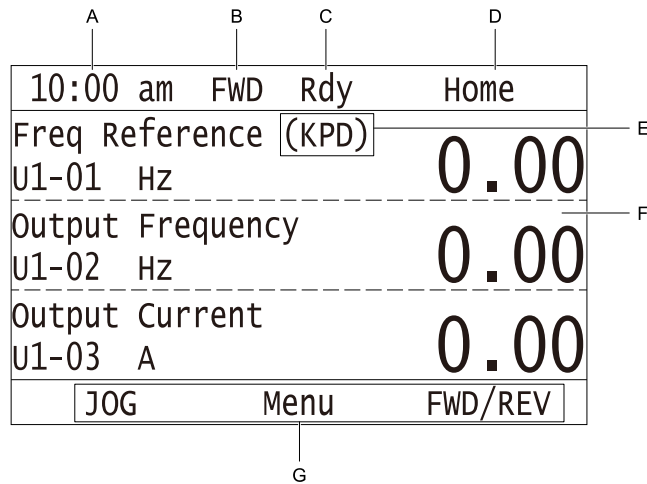






Figure 3.2 LCD Display Indications

Table 3.2 LCD Display Indications and Meanings

| Sym bol | Name                                 | Description  |
|---------|--------------------------------------|--|
| A       | Time display area                    | Shows the current time. Set the time on the default settings screen.   |
| B       | Forward run/Reverse indication       | Shows direction of motor rotation.<br><ul style="list-style-type: none"> <li>• FWD: Shown when set to Forward run.</li> <li>• REV: Shown when set to Reverse run.</li> </ul> <b>Note:</b><br>In DriveWorksEZ operation, FWD or REV flash.  |
| C       | Ready                                | The screen will show Rdy when the drive is ready for operation or when the drive is running.   |
| D       | Mode display area                    | Shows the name of the current mode or screen.  |
| E       | Frequency reference source indicator | Shows the current frequency reference source.<br><ul style="list-style-type: none"> <li>• KPD: keypad</li> <li>• AI: analog input terminal (terminals A1 to A3)</li> <li>• COM: MEMOBUS/Modbus communications</li> <li>• OPT: option card</li> <li>• RP: pulse train input terminal (terminal RP)</li> </ul> |
| F       | Data display area                    | Shows parameter values, monitor values, and details of the results of operations.  |
| G       | Function keys 1 to 3 (F1 to F3)      | The function names shown in this area will change when the selected screen changes. Push one of the function keys <b>F1</b> to <b>F3</b> on the keypad to do the function.   |

◆ Indicator LEDs and Drive Status

| LED  | Display          | Drive Status   |
|--|------------------|--|
| RUN LED<br>     | Illuminated      | The drive is operating the motor.  |
|  | Flashing         | <ul style="list-style-type: none"> <li>The drive is decelerating to stop.</li> <li>The drive received a Run command, but the frequency reference is 0 Hz.</li> <li>The drive received a DC Injection Braking command.</li> </ul>   |
|  | Flashing Quickly | <ul style="list-style-type: none"> <li>The drive received a Run command from the Multi-Function Digital Input (MFDI) terminals and is switching to REMOTE Mode while the drive is in LOCAL Mode.</li> <li>The drive received a Run command from an external source, but the drive is not in the Drive Ready (READY) condition.</li> <li>The drive received a Fast Stop command.</li> <li>The safety function shuts off the drive output.</li> <li>The user pushed  on the keypad while the drive is operating in REMOTE Mode.</li> <li>The drive is energized with an active Run command and <math>b1-17 = 0</math> [Run Command at Power Up = Disregard Existing RUN Command].</li> <li>When <math>b1-03 = 3</math> [Stopping Method Selection = Coast to Stop with Timer], the Run command is disabled then enabled during the Run wait time.</li> <li>The drive received a DC Injection Braking command.</li> <li>The voltage of the main circuit power supply decreased, and only the 24 V power supply is supplying power to the drive.</li> </ul> |
|  | OFF              | The motor is stopped.  |
| ALM LED<br>   | Illuminated      | The drive detects a fault.   |
|  | Flashing         | The drive detects: <ul style="list-style-type: none"> <li>An alarm</li> <li>An oPE parameter setting error</li> <li>An Auto-Tuning error</li> </ul> Note:<br>The digital characters shown on the keypad will also flash.   |
|  | OFF              | There are no drive faults or alarms.   |
| LO/RE LED<br> | Illuminated      | The keypad controls the Run command (LOCAL Mode).  |
|  | OFF              | The control circuit terminal or serial transmission device controls the Run command (REMOTE Mode).   |

■ LED Flashing Statuses

Refer to Figure 3.3 for the difference between “flashing” and “flashing quickly”.

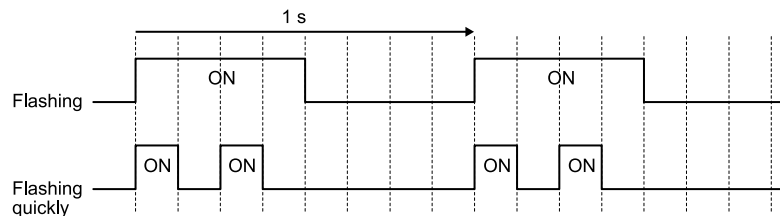


Figure 3.3 LED Flashing Statuses

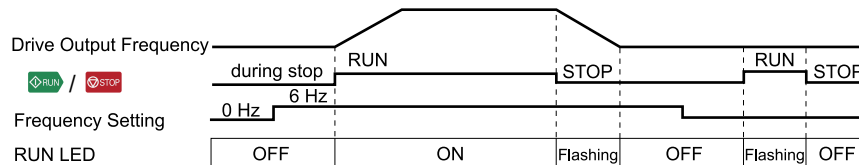


Figure 3.4 Relation between RUN LED and Drive Operation

◆ Keypad Mode and Menu Displays

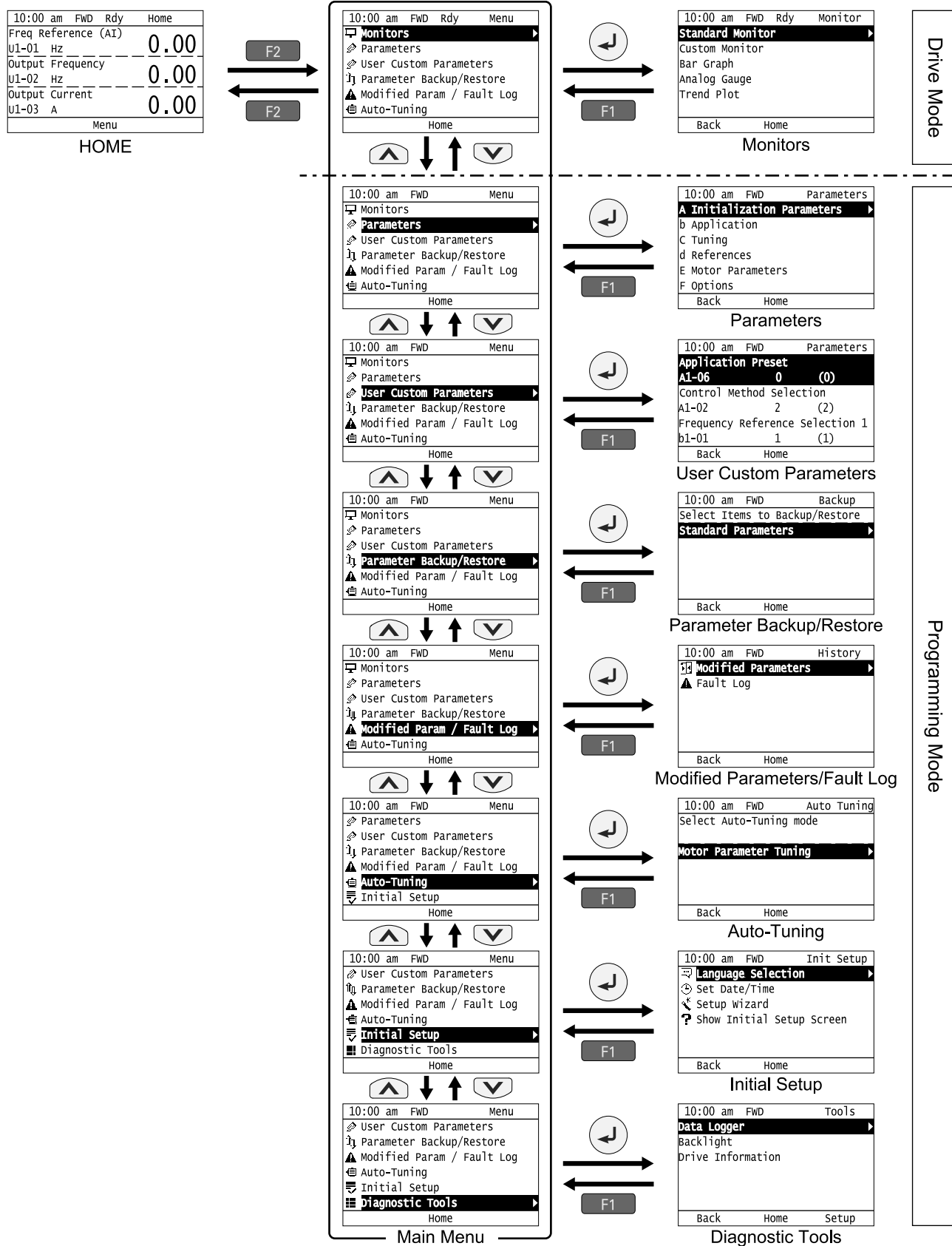




Figure 3.5 Keypad Functions and Display Levels

## 3.2 Keypad: Names and Functions

**Note:**

- Energize the drive with factory defaults to show the Initial Setup screen. Push **F2** (Home) to show the HOME screen.
  - Select [No] from the [Show Initial Setup Screen] setting to not display the Initial Setup screen.
- Push  from the Home screen to show drive monitors.
- Push  to set *d1-01 [Reference 1]* when the Home screen shows *U1-01 [Frequency Reference]* in LOCAL Mode.
- The keypad will show [Rdy] when the drive is in Drive Mode. The drive is prepared to accept a Run command.
- The drive will not accept a Run command in Programming Mode in the default setting. Set *b1-08 [Run Command Select in PRG Mode]* to accept or reject a Run command from an external source while in Programming Mode.
  - Set *b1-08 = 0 [Disregard RUN while Programming]* to reject the Run command from an external source while in Programming Mode (default).
  - Set *b1-08 = 1 [Accept RUN while Programming]* to accept the Run command from an external source while in Programming Mode.
  - Set *b1-08 = 2 [Allow Programming Only at Stop]* to prevent changes from Drive Mode to Programming Mode while the drive is operating.

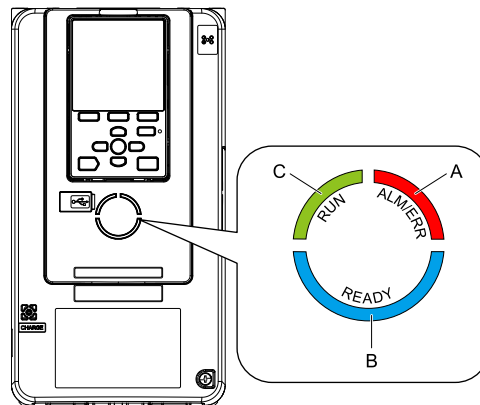
**Table 3.3 Drive Mode Screens and Functions**

| Mode             | Keypad Screen                 | Function                                     |
|------------------|-------------------------------|--|
| Drive Mode       | Monitors                      | Sets monitor items to display.               |
| Programming Mode | Parameters                    | Changes parameter settings.                  |
|                  | User Custom Parameters        | Shows the User Parameters.                   |
|                  | Parameter Backup/Restore      | Saves parameters to the keypad as backup.    |
|                  | Modified Parameters/Fault Log | Shows modified parameters and fault history. |
|                  | Auto-Tuning                   | Auto-Tunes the drive.                        |
|                  | Initial Setup                 | Changes initial settings.                    |
|                  | Diagnostic Tools              | Sets data logs and backlight.                |





### 3.3 LED Status Ring

The LED Status Ring on the drive cover shows the drive operating status.



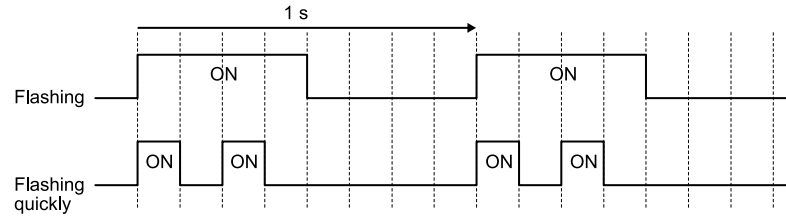
**A - ALM/ERR**  
**B - Ready**

**C - RUN**

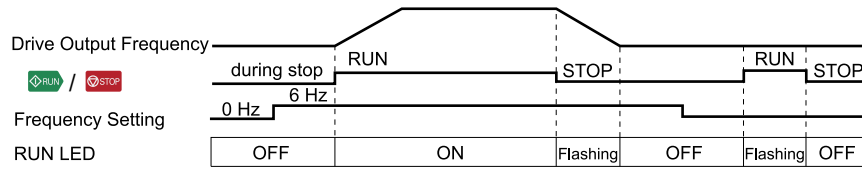
| LED | Status              | Description   |
|-----|---------------------|---|
| A   | ALM/ERR             |   |
|     | Illuminated         | The drive detects a fault.  |
|     | Flashing *1         | The drive detects: <ul style="list-style-type: none"> <li>An alarm</li> <li>An oPE parameter setting error</li> <li>An Auto-Tuning error</li> </ul> <b>Note:</b><br>The LED will illuminate to identify a fault if the drive detects a fault and an alarm at the same time.   |
|     | OFF                 | There are no drive faults or alarms.  |
| B   | Ready               |   |
|     | Illuminated         | The drive is operating or is prepared for operation.  |
|     | Flashing *1         | The drive is in <i>Sto</i> [Safe Torque OFF] condition.   |
|     | Flashing Quickly *1 | The voltage of the main circuit power supply dropped, and only the external 24 V power supply provides the power to the drive.  |
|     | OFF                 | <ul style="list-style-type: none"> <li>The drive detects a fault.</li> <li>There is no fault and the drive received a Run command, but the drive cannot operate. For example, in Programming Mode or when  is flashing.</li> </ul>   |
| C   | RUN                 |   |
|     | Illuminated         | The drive is in regular operation.  |
|     | Flashing *1         | <ul style="list-style-type: none"> <li>The drive is decelerating to stop.</li> <li>The drive received a Run command with a frequency reference of 0 Hz, but the drive is not set for zero speed control.</li> <li>The drive received a DC Injection Braking command.</li> </ul>   |
|     | Flashing Quickly *1 | <ul style="list-style-type: none"> <li>The drive received a Run command from the MFDI terminals and is switching to REMOTE Mode while the drive is in LOCAL Mode.</li> <li>The drive received a Run command from the MFDI terminals when the drive is not in Drive Mode.</li> <li>The drive received a Fast Stop command.</li> <li>The safety function shuts off the drive output.</li> <li>The user pushed  on the keypad while the drive is operating in REMOTE Mode.</li> <li>The drive is energized with an active Run command and <math>b1-17 = 0</math> [Run Command at Power Up = Disregard Existing RUN Command].</li> <li>The drive is set to coast-to-stop with timer (<math>b1-03 = 3</math> [Stopping Method Selection = Coast to Stop with Timer]), and the Run command is disabled then enabled during the Run wait time.</li> </ul> |
|     | OFF                 | The motor is stopped.   |

\*1 Refer to Figure 3.6 for the difference between “flashing” and “flashing quickly”.

### 3.3 LED Status Ring



**Figure 3.6 LED Flashing Statuses**



**Figure 3.7 Relation between RUN LED and Drive Operation**

## 3.4 Keypad Operation

### Note:

Use the keypad with FLASH number 1004 or later. Keypad with FLASH number 1003 or earlier does not show characters correctly.

### ◆ Use the HOME Screen



The functions that can be controlled from the HOME screen and the content that is displayed are explained in the following.

|                     |         |         |
|---------------------|---------|---------|
| 10:00 am            | FWD Rdy | Home    |
| Freq Reference(KPD) |         | 0.00    |
| U1-01 Hz            |         |         |
| Output Frequency    |         | 0.00    |
| U1-02 Hz            |         |         |
| Output Current      |         | 0.00    |
| U1-03 A             |         |         |
| JOG                 | Menu    | FWD/REV |

### ■ View Monitors Shown in Home Screen

This figure shows monitor data in the data display area of the HOME screen.

|                      |         |         |         |
|----------------------|---------|---------|---------|
| 10:00 am             | FWD Rdy | Home    |         |
| Freq Reference (KPD) |         | 0.00    | Monitor |
| U1-01 Hz             |         |         |         |
| Output Frequency     |         | 0.00    |         |
| U1-02 Hz             |         |         |         |
| Output Current       |         | 0.00    |         |
| U1-03 A              |         |         |         |
| JOG                  | Menu    | FWD/REV |         |

- To change what the screen shows, change the setting for *o1-40 [Home display selection]*.
- When *o1-40 [Home display selection]* is set to “Custom Monitor”, and there is more than one screen, use  or  to switch between screens.

### ■ JOG Operation

Push  to illuminate . Push  (JOG) to run the motor. Release  to stop the motor.

### ■ Change Motor between Forward/Reverse Run

You can change the direction of motor rotation when operating the drive from the keypad. Push  to illuminate





Push and hold  (FWD/REV) to toggle the direction of motor rotation between forward and reverse.


### ■ Show the Standard Monitor

Push  to show the standard monitor (*Ux-xx*). Push  (HOME) to go back to the HOME screen.

### Note:

When a fault, minor fault, or an error occurs, push  to show the content of the fault. Push  again to show the standard monitor (*Ux-xx*).

### ■ Change the Frequency Reference Value

1. Push  to access the screen to change the frequency.

### 3.4 Keypad Operation

2. Push or to select the specified digit, then push or to change the value.
3. Push to confirm the change.

**Note:**

The HOME screen must show *U1-01 [Frequency Reference]* or you must set the keypad as the Run command source (REMOTE) to use this function.

#### ■ Show the Main Menu

Push to show the main menu. Push (HOME) to go back to the HOME screen.

|                            |     |     |      |
|----------------------------|-----|-----|------|
| 10:00 am                   | FWD | Rdy | Menu |
| <b>Monitors</b>            |     |     |      |
| Parameters                 |     |     |      |
| User Custom Parameters     |     |     |      |
| Parameter Backup/Restore   |     |     |      |
| Modified Param / Fault Log |     |     |      |
| Auto-Tuning                |     |     |      |
| Home                       |     |     |      |

#### ◆ Displaying the Monitor

This section shows how to show the standard monitor (*Ux-xx*).

1. Push (Home) to show the HOME screen.

**Note:**

- When the drive is in HOME Mode, the screen shows [Home] in the upper right-hand corner of the screen.
- If the screen does not show [Home] for , push (Back), and then push to show [Home].

2. Push (Menu).

|                     |     |     |      |
|---------------------|-----|-----|------|
| 10:00 am            | FWD | Rdy | Home |
| Freq Reference (AI) |     |     |      |
| U1-01               | Hz  |     | 0.00 |
| Output Frequency    |     |     |      |
| U1-02               | Hz  |     | 0.00 |
| Output Current      |     |     |      |
| U1-03               | A   |     | 0.00 |
| Menu                |     |     |      |

3. Push or to select [Monitors], then push .

|                            |     |     |      |
|----------------------------|-----|-----|------|
| 10:00 am                   | FWD | Rdy | Menu |
| <b>Monitors</b>            |     |     |      |
| Parameters                 |     |     |      |
| User Custom Parameters     |     |     |      |
| Parameter Backup/Restore   |     |     |      |
| Modified Param / Fault Log |     |     |      |
| Auto-Tuning                |     |     |      |
| Home                       |     |     |      |

4. Push or to select [Standard Monitor], then push .

|                         |     |      |         |
|-------------------------|-----|------|---------|
| 10:00 am                | FWD | Rdy  | Monitor |
| <b>Standard Monitor</b> |     |      |         |
| Custom Monitor          |     |      |         |
| Bar Graph               |     |      |         |
| Analog Gauge            |     |      |         |
| Trend Plot              |     |      |         |
| Back                    |     | Home |         |

5. Push or to select the monitor group, then push .

|                                       |     |      |         |
|---------------------------------------|-----|------|---------|
| 10:00 am                              | FWD | Rdy  | Monitor |
| <b>U1 Operation Status Monitors</b> ▶ |     |      |         |
| U2 Fault Trace                        |     |      |         |
| U3 Fault History                      |     |      |         |
| U4 Maintenance Monitors               |     |      |         |
| U5 PID Monitors                       |     |      |         |
| U6 Operation Status Monitors          |     |      |         |
| Back                                  |     | Home |         |

6. Push or to change the monitor number to show the monitor item.

**Note:**

Push to return to the previous page.

|                      |     |     |         |
|----------------------|-----|-----|---------|
| 10:00 am             | FWD | Rdy | Monitor |
| Terminal A1 Input Lv |     |     | 0.0     |
| U1-13 %              |     |     |         |
| Terminal A2 Input Lv |     |     | 0.0     |
| U1-14 %              |     |     |         |
| Terminal A3 Input Lv |     |     | 0.0     |
| U1-15 %              |     |     |         |
| Home                 |     |     |         |

◆ **Set Custom Monitors**

You can select and register a maximum of 12 monitoring items to regularly show on the keypad. This procedure shows how to set the motor speed to [Custom Monitor 1].

1. Push (Home) to show the HOME screen.

**Note:**

- The keypad will show [Home] in the top right corner when the HOME screen is active.
- If [Home] is not shown on , push (Back) to show [Home] on .

2. Push (Menu).

|                     |     |     |      |
|---------------------|-----|-----|------|
| 10:00 am            | FWD | Rdy | Home |
| Freq Reference (AI) |     |     | 0.00 |
| U1-01 Hz            |     |     |      |
| Output Frequency    |     |     | 0.00 |
| U1-02 Hz            |     |     |      |
| Output Current      |     |     | 0.00 |
| U1-03 A             |     |     |      |
| Menu                |     |     |      |




3. Push or to select [Monitors], then push .

|                            |     |     |      |
|----------------------------|-----|-----|------|
| 10:00 am                   | FWD | Rdy | Menu |
| <b>Monitors</b> ▶          |     |     |      |
| Parameters                 |     |     |      |
| User Custom Parameters     |     |     |      |
| Parameter Backup/Restore   |     |     |      |
| Modified Param / Fault Log |     |     |      |
| Auto-Tuning                |     |     |      |
| Home                       |     |     |      |




4. Push or to select [Custom Monitor], then push (Setup).

|                         |     |            |         |
|-------------------------|-----|------------|---------|
| 10:00 am                | FWD | Rdy        | Monitor |
| Standard Monitor        |     |            |         |
| <b>Custom Monitor</b> ▶ |     |            |         |
| Bar Graph               |     |            |         |
| Analog Gauge            |     |            |         |
| Trend Plot              |     |            |         |
| Back                    |     | Home Setup |         |

### 3.4 Keypad Operation

5. Push  or  to select [Custom Monitor 1], then push .

|                         |       |
|-------------------------|-------|
| 10:00 am FWD            | Setup |
| <b>Custom Monitor 1</b> | ▶     |
| Custom Monitor 2        |       |
| Custom Monitor 3        |       |
| Custom Monitor 4        |       |
| Custom Monitor 5        |       |
| Custom Monitor 6        |       |
| Back                    | Home  |


6. Push  or  to select the monitor number to register, then push .  
Enter the three digits in “x-xx” part of monitor *Ux-xx* to identify which monitor to output. For example, to show monitor *U1-05*, set it to “105” as shown in this figure.

|                     |            |
|---------------------|------------|
| 10:00 am FWD        | Parameters |
| Custom Monitor 1    |            |
| 01-24               | <b>105</b> |
| Frequency Reference |            |
| Default : 101       |            |
| Back                | Default    |




The configuration procedure is complete.

#### ◆ Show Custom Monitors

The procedure in this section shows how to show the registered custom monitors.

1. Push  (Home) to show the HOME screen.

**Note:**


- The keypad will show [Home] in the top right corner when the HOME screen is active.
- If [Home] is not shown on , push  (Back) to show [Home] on .

2. Push  (Menu).

|                     |      |
|---------------------|------|
| 10:00 am FWD Rdy    | Home |
| Freq Reference (AI) | 0.00 |
| U1-01 Hz            | 0.00 |
| Output Frequency    | 0.00 |
| U1-02 Hz            | 0.00 |
| Output Current      | 0.00 |
| U1-03 A             | 0.00 |
| Menu                |      |

3. Push  or  to select [Monitors], then push .

|                            |      |
|----------------------------|------|
| 10:00 am FWD Rdy           | Menu |
| <b>Monitors</b>            | ▶    |
| Parameters                 |      |
| User Custom Parameters     |      |
| Parameter Backup/Restore   |      |
| Modified Param / Fault Log |      |
| Auto-Tuning                |      |
| Home                       |      |

4. Push  or  to select [Custom Monitor], then push .

|                       |            |
|-----------------------|------------|
| 10:00 am FWD Rdy      | Monitor    |
| Standard Monitor      |            |
| <b>Custom Monitor</b> | ▶          |
| Bar Graph             |            |
| Analog Gauge          |            |
| Trend Plot            |            |
| Back                  | Home Setup |

The keypad shows the selected monitor as shown in this figure.

|                      |         |
|----------------------|---------|
| 10:00 am FWD Rdy     | Monitor |
| Motor Speed          |         |
| U1-05 Hz             | 20.00   |
| Output Power         |         |
| U1-08 kw             | 15.0    |
| Terminal AI Input Lv |         |
| U1-13 %              | 30.0    |
| Home                 |         |

- When there are a minimum of two screens, push or to switch between screens.
- If you registered only one custom monitor to [Custom Monitor 1], the screen will show only one monitor. If you registered custom monitors only to [Custom Monitor 1] and [Custom Monitor 2], the screen will show only two monitors.

### ◆ Set the Monitors to Show as a Bar Graph

The procedure in this section shows how to show the frequency reference monitor as a bar graph.

1. Push (Home) to show the HOME screen.

**Note:**

- The keypad will show [Home] in the top right corner when the HOME screen is active.
- If [Home] is not shown on , push (Back) to show [Home] on .

2. Push (Menu).

|                     |      |
|---------------------|------|
| 10:00 am FWD Rdy    | Home |
| Freq Reference (AI) |      |
| U1-01 Hz            | 0.00 |
| Output Frequency    |      |
| U1-02 Hz            | 0.00 |
| Output Current      |      |
| U1-03 A             | 0.00 |
| Menu                |      |

3. Push or to select [Monitors], then push .

|                            |      |
|----------------------------|------|
| 10:00 am FWD Rdy           | Menu |
| <b>Monitors</b>            |      |
| Parameters                 |      |
| User Custom Parameters     |      |
| Parameter Backup/Restore   |      |
| Modified Param / Fault Log |      |
| Auto-Tuning                |      |
| Home                       |      |


4. Push or to select [Bar Graph], then push (Setup).

|                  |            |
|------------------|------------|
| 10:00 am FWD Rdy | Monitor    |
| Standard Monitor |            |
| Custom Monitor   |            |
| <b>Bar Graph</b> |            |
| Analog Gauge     |            |
| Trend Plot       |            |
| Back             | Home Setup |

5. Push or to select the location to store the monitor, then push .

|                         |       |
|-------------------------|-------|
| 10:00 am FWD            | Setup |
| <b>Custom Monitor 1</b> |       |
| Custom Monitor 2        |       |
| Custom Monitor 3        |       |
| Back Home               |       |

### 3.4 Keypad Operation

6. Push .

|                            |      |       |
|----------------------------|------|-------|
| 10:00 am                   | FWD  | Setup |
| Custom Monitor 1           |      |       |
| <b>Custom Monitor 1</b>    |      |       |
| o1-24                      | 101  | (101) |
| 1st Monitor Area Selection |      |       |
| o1-41                      | 0    | (0)   |
| Back                       | Home |       |

7. Push  or  to select the monitor number to register, then push .


Enter the three digits in “x-xx” part of monitor *Ux-xx* to identify which monitor to output. For example, to show monitor *U1-01 [Frequency Reference]*, set it to “101” as shown in this figure.

|                     |            |            |
|---------------------|------------|------------|
| 10:00 am            | FWD        | Parameters |
| Custom Monitor 1    |            |            |
| o1-24               | <b>101</b> |            |
| Frequency Reference |            |            |
| Default : 101       |            |            |
| Back                | Default    |            |




The configuration procedure is complete.

#### ◆ Show Monitors as Bar Graphs

The procedure in this section shows how to show a specific monitor as a bar graph. You can show a maximum of three.

1. Push  (Home) to display the HOME screen.

**Note:**

- [Home] appears in the upper right hand corner of the screen when in HOME mode.
- If [Home] is not shown on , push  (Back) to show [Home] on .

2. Push  (Menu).

|                     |     |     |      |
|---------------------|-----|-----|------|
| 10:00 am            | FWD | Rdy | Home |
| Freq Reference (AI) |     |     |      |
| U1-01               | Hz  |     | 0.00 |
| Output Frequency    |     |     |      |
| U1-02               | Hz  |     | 0.00 |
| Output Current      |     |     |      |
| U1-03               | A   |     | 0.00 |
| Menu                |     |     |      |

3. Push  or  to select [Display Monitor], then push .

|                            |     |     |      |
|----------------------------|-----|-----|------|
| 10:00 am                   | FWD | Rdy | Menu |
| <b>Monitors</b>            |     |     |      |
| Parameters                 |     |     |      |
| User Custom Parameters     |     |     |      |
| Parameter Backup/Restore   |     |     |      |
| Modified Param / Fault Log |     |     |      |
| Auto-Tuning                |     |     |      |
| Home                       |     |     |      |

4. Push  or  to select [Display Bar Graph], and push .

|                  |      |       |         |
|------------------|------|-------|---------|
| 10:00 am         | FWD  | Rdy   | Monitor |
| Standard Monitor |      |       |         |
| Custom Monitor   |      |       |         |
| <b>Bar Graph</b> |      |       |         |
| Analog Gauge     |      |       |         |
| Trend Plot       |      |       |         |
| Back             | Home | Setup |         |



The screen will show the monitors as shown in this figure.

| 10:00 am | FWD   | Rdy | Monitor |
|----------|-------|-----|---------|
| U1-01    |       |     |         |
| 40.00Hz  | -100% | 0%  | 100%    |
| U1-02    |       |     |         |
| 40.00Hz  | -100% | 0%  | 100%    |
| U1-03    |       |     |         |
| 3.0A     | -100% | 0%  | 100%    |
| Home     |       |     |         |

### ◆ Set the Monitors to Show as Analog Gauges

The procedure in this section shows how to show the frequency reference monitor as an analog gauge.

1. Push **F2** (Home) to show the HOME screen.

**Note:**

- The keypad will show [Home] in the top right corner when the HOME screen is active.
- If [Home] is not shown on **F2**, push **F1** (Back) to show [Home] on **F2**.

2. Push **F2** (Menu).

| 10:00 am            | FWD | Rdy | Home |
|---------------------|-----|-----|------|
| Freq Reference (AI) |     |     |      |
| U1-01 Hz            |     |     | 0.00 |
| Output Frequency    |     |     |      |
| U1-02 Hz            |     |     | 0.00 |
| Output Current      |     |     |      |
| U1-03 A             |     |     | 0.00 |
| Menu                |     |     |      |

3. Push  or  to select [Monitors], then push .

| 10:00 am                   | FWD | Rdy | Menu |
|----------------------------|-----|-----|------|
| <b>Monitors</b>            |     |     |      |
| Parameters                 |     |     |      |
| User Custom Parameters     |     |     |      |
| Parameter Backup/Restore   |     |     |      |
| Modified Param / Fault Log |     |     |      |
| Auto-Tuning                |     |     |      |
| Home                       |     |     |      |

4. Push  or  to select [Analog Gauge], then push **F3** (Setup).

| 10:00 am            | FWD  | Rdy   | Monitor |
|---------------------|------|-------|---------|
| Standard Monitor    |      |       |         |
| Custom Monitor      |      |       |         |
| Bar Graph           |      |       |         |
| <b>Analog Gauge</b> |      |       |         |
| Trend Plot          |      |       |         |
| Back                | Home | Setup |         |

5. Push .

| 10:00 am                    | FWD  | Setup |
|-----------------------------|------|-------|
| Analog Gauge                |      |       |
| <b>Custom Monitor 1</b>     |      |       |
| o1-24                       | 101  | (101) |
| Analog Gauge Area Selection |      |       |
| o1-55                       | 1    | (1)   |
| Back                        | Home |       |

6. Push  or  to select the monitor number to register, then push .

Enter the three digits in "x-xx" part of monitor  $U_x\text{-xx}$  to identify which monitor to output. For example, to show monitor  $U1\text{-}01$  [Frequency Reference], set it to "101" as shown in this figure.

### 3.4 Keypad Operation

|                     |            |
|---------------------|------------|
| 10:00 am FWD        | Parameters |
| Custom Monitor 1    |            |
| o1-24               | <b>101</b> |
| Frequency Reference |            |
| Default : 101       |            |
| Back                | Default    |

The configuration procedure is complete.

#### ◆ Display Monitors as an Analog Gauge

The following explains how to display the contents selected for a monitor as an analog gauge.

1. Push **F2** (Home) to show the HOME screen.

**Note:**

- The keypad will show [Home] in the top right corner when the HOME screen is active.
- If [Home] is not on **F2**, push **F1** (Back) to show [Home] on **F2**.

2. Push **F2** (Menu).

|                     |      |
|---------------------|------|
| 10:00 am FWD Rdy    | Home |
| Freq Reference (AI) | 0.00 |
| U1-01 Hz            | 0.00 |
| Output Frequency    | 0.00 |
| U1-02 Hz            | 0.00 |
| Output Current      | 0.00 |
| U1-03 A             | 0.00 |
| Menu                |      |

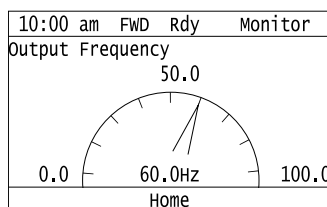
3. Push  or  to select [Monitors], then push .

|                            |      |
|----------------------------|------|
| 10:00 am FWD Rdy           | Menu |
| <b>Monitors</b>            |      |
| Parameters                 |      |
| User Custom Parameters     |      |
| Parameter Backup/Restore   |      |
| Modified Param / Fault Log |      |
| Auto-Tuning                |      |
| Home                       |      |

4. Push  or  to select [Analog Gauge], then push .

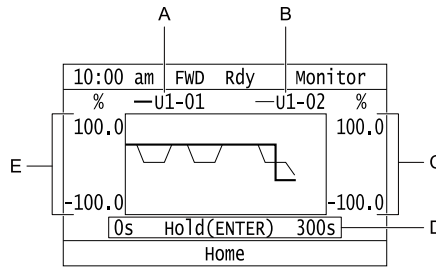
|                     |            |
|---------------------|------------|
| 10:00 am FWD Rdy    | Monitor    |
| Standard Monitor    |            |
| Custom Monitor      |            |
| Bar Graph           |            |
| <b>Analog Gauge</b> |            |
| Trend Plot          |            |
| Back                | Home Setup |

It will be displayed as follows.



#### ◆ Set Monitoring Items to be Shown as a Trend Plot

You must set the items in this figure to display as a trend plot.



- A - Monitor Parameter 1 (set with [Custom Monitor 1])
- B - Monitor Parameter 2 (set with [Custom Monitor 2])
- C - Trend Plot 2 Scale Maximum/Minimum Value
- D - Trend Plot Time Scale
- E - Trend Plot 1 Scale Maximum/Minimum Value

### ■ Select Monitor Items to Show as a Trend Plot

The procedure in this section shows how to show the frequency reference monitor as a trend plot.

1. Push **F2** (Home) to show the HOME screen.

**Note:**

- The keypad will show [Home] in the top right corner when the HOME screen is active.
- If [Home] is not shown on **F2**, push **F1** (Back) to show [Home] on **F2**.

2. Push **F2** (Menu).

|                     |     |     |      |
|---------------------|-----|-----|------|
| 10:00 am            | FWD | Rdy | Home |
| Freq Reference (AI) |     |     |      |
| U1-01               | Hz  |     | 0.00 |
| -----               |     |     |      |
| Output Frequency    |     |     |      |
| U1-02               | Hz  |     | 0.00 |
| -----               |     |     |      |
| Output Current      |     |     |      |
| U1-03               | A   |     | 0.00 |
| -----               |     |     |      |
| Menu                |     |     |      |

3. Push **▲** or **▼** to select [Monitors], then push **↶**.

|                            |     |     |      |
|----------------------------|-----|-----|------|
| 10:00 am                   | FWD | Rdy | Menu |
| Monitors                   |     |     |      |
| Parameters                 |     |     |      |
| User Custom Parameters     |     |     |      |
| Parameter Backup/Restore   |     |     |      |
| Modified Param / Fault Log |     |     |      |
| Auto-Tuning                |     |     |      |
| -----                      |     |     |      |
| Home                       |     |     |      |


4. Push **▲** or **▼** to select [Trend Plot], then push **F3** (Setup).

|                  |      |       |         |
|------------------|------|-------|---------|
| 10:00 am         | FWD  | Rdy   | Monitor |
| Standard Monitor |      |       |         |
| Custom Monitor   |      |       |         |
| Bar Graph        |      |       |         |
| Analog Gauge     |      |       |         |
| Trend Plot       |      |       |         |
| -----            |      |       |         |
| Back             | Home | Setup |         |

5. Push **▲** or **▼** to select [Custom Monitor 1], then push **↶**.

|                               |      |       |  |
|-------------------------------|------|-------|--|
| 10:00 am                      | FWD  | Setup |  |
| Custom Monitor 1              |      |       |  |
| Custom Monitor 2              |      |       |  |
| Trend Plot Time Scale Setting |      |       |  |
| -----                         |      |       |  |
| Back                          | Home |       |  |

### 3.4 Keypad Operation

6. Push .

|                                  |                  |
|----------------------------------|------------------|
| 10:00 am FWD                     | Setup            |
| Custom Monitor 1                 |                  |
| <b>Custom Monitor 1</b>          |                  |
| o1-24                            | 101 (101)        |
| Trend Plot 1 Scale Minimum Value |                  |
| o1-47                            | -100.0 (-100.0)% |
| Back                             | Home             |





7. Push  or  to select the monitor number to register, then push .

When the *U parameters* are on the display as "Ux-xx", the three digits in "x-xx" identify which monitor to output. For example, to show monitor *U1-01 [Frequency Reference]*, set it to "101" as shown in this figure.



|                     |            |
|---------------------|------------|
| 10:00 am FWD        | Parameters |
| Custom Monitor 1    |            |
| o1-24               | <b>101</b> |
| Frequency Reference |            |
| Default : 101       |            |
| Back                | Default    |


8. Push  or  to select [Trend Plot 1 Scale Minimum Value], then push .

|   |                  |
|---|------------------|
| 10:00 am FWD                            | Setup            |
| Custom Monitor 1                        |                  |
| <b>Trend Plot 1 Scale Minimum Value</b> |                  |
| o1-47                                   | -100.0 (-100.0)% |
| Trend Plot 1 Scale Maximum Value        |                  |
| o1-48                                   | 100.0 ( 100.0)%  |
| Back                                    | Home             |




9. Push  or  to select the specified digit, then push  or  to select the correct number.

|                                  |                  |
|----------------------------------|------------------|
| 10:00 am FWD                     | Parameters       |
| Trend Plot 1 Scale Minimum Value |                  |
| o1-47                            | <b>-</b> 100.0 % |
| Default : -100.0%                |                  |
| Range : -300.0~ 99.9             |                  |
| Back                             | Default Min/Max  |

- Push  (Default) to set the parameters to the factory default.
- Push  (Min/Max) to move between the minimum value and maximum value.

10. Push  to keep the changes.

|                                  |                   |
|----------------------------------|-------------------|
| 10:00 am FWD                     | Parameters        |
| Trend Plot 1 Scale Minimum Value |                   |
| o1-47                            | 00 <b>2</b> 0.0 % |
| Default : -100.0%                |                   |
| Range : -300.0~ 99.9             |                   |
| Back                             | Default Min/Max   |

11. Push  or  to select [Trend Plot 1 Scale Maximum Value], then push .

|   |                 |
|---|-----------------|
| 10:00 am FWD                            | Setup           |
| Custom Monitor 1                        |                 |
| Trend Plot 1 Scale Minimum Value        |                 |
| o1-47                                   | 100.0 (-100.0)% |
| <b>Trend Plot 1 Scale Maximum Value</b> |                 |
| o1-48                                   | 100.0 ( 100.0)% |
| Back                                    | Home            |

12. Push or to select the specified digit, then push or to select the correct number.

|                                  |         |            |
|----------------------------------|---------|------------|
| 10:00 am                         | FWD     | Parameters |
| Trend Plot 1 Scale Maximum Value |         |            |
| 01-48                            | 0       | 100.0 %    |
| Default : 100.0%                 |         |            |
| Range : 20.1~ 300.0              |         |            |
| Back                             | Default | Min/Max    |

- Push (Default) to set the parameters to the factory default.
- Push (Min/Max) to move between the minimum value and maximum value.

13. Push to keep the changes.

|                                  |         |            |
|----------------------------------|---------|------------|
| 10:00 am                         | FWD     | Parameters |
| Trend Plot 1 Scale Maximum Value |         |            |
| 01-48                            | 00      | 80.0 %     |
| Default : 100.0%                 |         |            |
| Range : 20.1~ 300.0              |         |            |
| Back                             | Default | Min/Max    |

14. Push (Back).

If necessary, use the same procedure to set [Custom Monitor 2].

### ■ Set the Time Scale for the Trend Plot Monitor

The procedure in this section shows how to set the time scale for the trend plot monitor.

1. Push (Home) to show the HOME screen.

**Note:**

- The keypad will show [Home] in the top right corner when the HOME screen is active.
- If [Home] is not shown on , push (Back) to show [Home] on .

2. Push (Menu).

|                     |     |     |      |
|---------------------|-----|-----|------|
| 10:00 am            | FWD | Rdy | Home |
| Freq Reference (AI) |     |     |      |
| U1-01               | Hz  |     | 0.00 |
| Output Frequency    |     |     |      |
| U1-02               | Hz  |     | 0.00 |
| Output Current      |     |     |      |
| U1-03               | A   |     | 0.00 |
| Menu                |     |     |      |




3. Push or to select [Monitors], then push .

|                            |     |     |      |
|----------------------------|-----|-----|------|
| 10:00 am                   | FWD | Rdy | Menu |
| Monitors                   |     |     |      |
| Parameters                 |     |     |      |
| User Custom Parameters     |     |     |      |
| Parameter Backup/Restore   |     |     |      |
| Modified Param / Fault Log |     |     |      |
| Auto-Tuning                |     |     |      |
| Home                       |     |     |      |





4. Push or to select [Trend Plot], then push (Setup).

|                  |      |       |         |
|------------------|------|-------|---------|
| 10:00 am         | FWD  | Rdy   | Monitor |
| Standard Monitor |      |       |         |
| Custom Monitor   |      |       |         |
| Bar Graph        |      |       |         |
| Analog Gauge     |      |       |         |
| Trend Plot       |      |       |         |
| Back             | Home | Setup |         |



### 3.4 Keypad Operation


5. Push  or  to select [Trend Plot Time Scale Setting], then push .

|  |      |       |
|--|------|-------|
| 10:00 am                               | FWD  | Setup |
| 1st Monitor Setting                    |      |       |
| 2nd Monitor Setting                    |      |       |
| <b>Trend Plot Time Scale Setting</b> ▶ |      |       |
|  |      |       |
| Back                                   | Home |       |

6. Push  or  to select the specified digit, then push  or  to select the correct number.

|                               |          |            |
|-------------------------------|----------|------------|
| 10:00 am                      | FWD      | Parameters |
| Trend Plot Time Scale Setting |          |            |
| 01-51                         | <b>0</b> | 300 sec    |
| Default : 300sec              |          |            |
| Range : 1~3600                |          |            |
| Back                          | Default  | Min/Max    |

- Push  (Default) to set the parameters to the factory default.
- Push  (Min/Max) to move between the minimum value and maximum value.


7. Push  to keep the changes.

|                               |          |            |
|-------------------------------|----------|------------|
| 10:00 am                      | FWD      | Parameters |
| Trend Plot Time Scale Setting |          |            |
| 01-51                         | <b>1</b> | 300 sec    |
| Default : 300sec              |          |            |
| Range : 1~3600                |          |            |
| Back                          | Default  | Min/Max    |




The configuration procedure is complete.

#### ◆ Show Monitor Items as a Trend Plot

The procedure in this section shows how to show the selected monitor data as a trend plot.

1. Push  (Home) to show the HOME screen.

**Note:**

- The keypad will show [Home] in the top right corner when the HOME screen is active.
- If [Home] is not shown on , push  (Back) to show [Home] on .

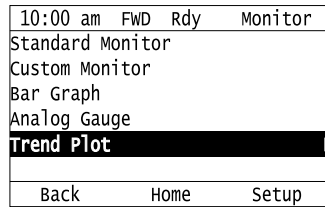
2. Push  (Menu).

|                     |     |     |      |
|---------------------|-----|-----|------|
| 10:00 am            | FWD | Rdy | Home |
| Freq Reference (AI) |     |     |      |
| U1-01               | Hz  |     | 0.00 |
| Output Frequency    |     |     |      |
| U1-02               | Hz  |     | 0.00 |
| Output Current      |     |     |      |
| U1-03               | A   |     | 0.00 |
| Menu                |     |     |      |

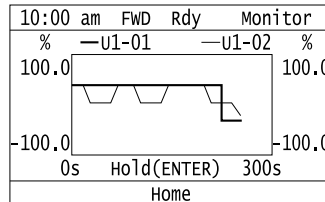
3. Push  or  to select [Monitors], then push .

|                            |     |     |      |
|----------------------------|-----|-----|------|
| 10:00 am                   | FWD | Rdy | Menu |
| <b>Monitors</b> ▶          |     |     |      |
| Parameters                 |     |     |      |
| User Custom Parameters     |     |     |      |
| Parameter Backup/Restore   |     |     |      |
| Modified Param / Fault Log |     |     |      |
| Auto-Tuning                |     |     |      |
| Home                       |     |     |      |


4. Push  or  to select [Trend Plot], then push .



The screen will show the monitors as shown in this figure.




**Note:**



Push  (Hold) to switch between Pause and Restart for the monitor display. The “Hold (ENTER)” message flashes while monitoring is paused.

### ◆ Change Parameter Settings

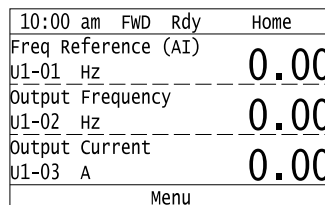
This example shows how to change the setting value for C1-01 [Acceleration Time 1]. Do the steps in this procedure to set parameters for the application.

1. Push  (Home) to show the HOME screen.

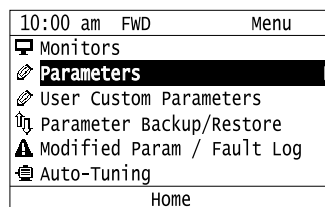
**Note:**

- When the drive is in HOME Mode, the screen shows [Home] in the upper right-hand corner of the screen.
- If [Home] is not shown above the , push  (Back).

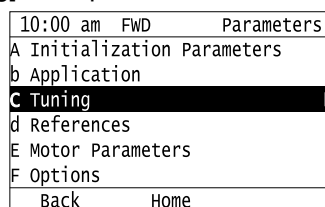
2. Push  (Menu).






3. Push  or  to select [Parameters], then push .






4. Push  or  to select [C Tuning], then push .







### 3.4 Keypad Operation

5. Push  or  to select [C1 Accel & Decel Time], then push .



|                             |      |            |
|-----------------------------|------|------------|
| 10:00 am                    | FWD  | Parameters |
| C1 Accel & Decel Time       |      |            |
| C2 S-Curve Characteristics  |      |            |
| C3 Slip Compensation        |      |            |
| C4 Torque Compensation      |      |            |
| C6 Duty & Carrier Frequency |      |            |
| Back                        | Home |            |


6. Push  or  to select C1-01, then push .

|                     |      |            |
|---------------------|------|------------|
| 10:00 am            | FWD  | Parameters |
| Acceleration Time 1 |      |            |
| C1-01               | 10.0 | (10.0)sec  |
| Deceleration Time 1 |      |            |
| C1-02               | 10.0 | (10.0)sec  |
| Acceleration Time 2 |      |            |
| C1-03               | 10.0 | (10.0)sec  |
| Back                | Home |            |

7. Push  or  to select the specified digit, then push  or  to select the correct number.

|                     |           |            |
|---------------------|-----------|------------|
| 10:00 am            | FWD       | Parameters |
| Acceleration Time 1 |           |            |
| C1-01               | 0010.0sec |            |
| Default : 10.0sec   |           |            |
| Range : 0.0~6000.0  |           |            |
| Back                | Default   | Min/Max    |

- Push  [Default] to set the parameters to factory defaults.
- Push  [Min/Max] to show the minimum value or the maximum value on the display.

8. Push  to keep the changes.

|                     |            |            |
|---------------------|------------|------------|
| 10:00 am            | FWD        | Parameters |
| Acceleration Time 1 |            |            |
| C1-01               | 0020.0 sec |            |
| Default : 10.0 sec  |            |            |
| Range : 0.0~6000.0  |            |            |
| Back                | Default    | Min/Max    |


9. Continue to change parameters, then push  [Back],  [Home] to go back to the home screen after you change all the applicable parameters.

#### ◆ Examine User Custom Parameters




The User Custom Parameters show the parameters set in A2-01 to A2-32 [User Parameter 1 to User Parameter 32]. This lets users to quickly access and change settings to these parameters.

**Note:**

The User Custom Parameters always show A1-06 [Application Selection] at the top of the list. The A2-01 to A2-32 settings change when the A1-06 setting changes, which makes it easier to set and reference the necessary parameter settings.

1. Push  (Home) to show the HOME screen.

**Note:**

- The keypad will show [Home] in the top right corner when the HOME screen is active.
- If [Home] is not shown on , push  (Back) to show [Home] on .



2. Push **F2** (Menu).

|                     |         |      |
|---------------------|---------|------|
| 10:00 am            | FWD Rdy | Home |
| Freq Reference (AI) |         |      |
| U1-01               | Hz      | 0.00 |
| Output Frequency    |         |      |
| U1-02               | Hz      | 0.00 |
| Output Current      |         |      |
| U1-03               | A       | 0.00 |
| Menu                |         |      |

3. Push **▲** or **▼** to select [User Custom Parameters], then push **↵**.

|                               |     |      |
|-------------------------------|-----|------|
| 10:00 am                      | FWD | Menu |
| Monitors                      |     |      |
| Parameters                    |     |      |
| <b>User Custom Parameters</b> |     |      |
| Parameter Backup/Restore      |     |      |
| Modified Param / Fault Log    |     |      |
| Auto-Tuning                   |     |      |
| Home                          |     |      |

4. Push **▲** or **▼** to show the parameter to examine.

|                                 |      |            |
|---------------------------------|------|------------|
| 10:00 am                        | FWD  | Parameters |
| <b>Application Preset</b>       |      |            |
| A1-06                           | 0    | (0)        |
| Control Method Selection        |      |            |
| A1-02                           | 2    | (2)        |
| Frequency Reference Selection 1 |      |            |
| b1-01                           | 1    | (1)        |
| Back                            | Home |            |

5. To change the parameter settings, push **▲** or **▼** to select the parameter, then push **↵**.

|                                 |      |            |
|---------------------------------|------|------------|
| 10:00 am                        | FWD  | Parameters |
| <b>Application Preset</b>       |      |            |
| A1-06                           | 0    | (0)        |
| <b>Control Method Selection</b> |      |            |
| A1-02                           | 2    | (2)        |
| Frequency Reference Selection 1 |      |            |
| b1-01                           | 1    | (1)        |
| Back                            | Home |            |

6. Push **◀** or **▶** to select the digit, then push **▲** or **▼** to change the value.

|                          |          |            |
|--------------------------|----------|------------|
| 10:00 am                 | FWD      | Parameters |
| Control Method Selection |          |            |
| A1-02                    | <b>2</b> |            |
| Open Loop Vector Control |          |            |
| Default : 2              |          |            |
| Back                     | Default  |            |

7. Change the value, push **↵**.

|                          |          |            |
|--------------------------|----------|------------|
| 10:00 am                 | FWD      | Parameters |
| Control Method Selection |          |            |
| A1-02                    | <b>0</b> |            |
| V/f Control              |          |            |
| Default : 2              |          |            |
| Back                     | Default  |            |

The parameter setting procedure is complete.

### ◆ Save a Backup of Parameters

You can save a backup of the drive parameters to the keypad. The keypad can store parameter setting values for a maximum of four drives in different storage areas. Making backups of the parameter settings can save time when setting parameters after replacing a drive. If you set up more than one drive, you can copy the parameter settings from a drive that completed a test run to the other drives.

**Note:**

- Be sure to stop the monitor before backing up parameters.
- While making a backup, the drive will not accept Run commands.
- The DriveWorksEZ PC software password is required to back up *qx-xx* [DriveWorksEZ Parameter] and *rx-xx* [DWEZ Connection Parameter]. If an incorrect password is entered, the drive detects *PWEr* [DWEZ Password Mismatch].

1. Push **F2** (Home) to show the HOME screen.







**Note:**




- When the drive is in HOME Mode, the screen shows [Home] in the upper right-hand corner of the screen.
- If the screen does not show [Home] for **F2**, push **F1** (Back), and then push **F2** to show [Home].

2. Push **F2** (Menu).

|                     |     |     |      |
|---------------------|-----|-----|------|
| 10:00 am            | FWD | Rdy | Home |
| Freq Reference (AI) |     |     |      |
| U1-01               | Hz  |     | 0.00 |
| Output Frequency    |     |     |      |
| U1-02               | Hz  |     | 0.00 |
| Output Current      |     |     |      |
| U1-03               | A   |     | 0.00 |
| Menu                |     |     |      |

3. Push  or  to select [Parameter Backup/Restore], then push .




|   |                                 |  |      |
|---|---------------------------------|--|------|
| 10:00 am  | FWD                             |  | Menu |
|  | Monitors                        |  |      |
|  | Parameters                      |  |      |
|  | User Custom Parameters          |  |      |
|  | <b>Parameter Backup/Restore</b> |  |      |
|  | Modified Param / Fault Log      |  |      |
|  | Auto-Tuning                     |  |      |
| Home  |                                 |  |      |

4. Push  or  to select the items to back up, then push .

|                                |                            |      |        |
|--------------------------------|----------------------------|------|--------|
| 10:00 am                       | FWD                        |      | Backup |
| Select Items to Backup/Restore |                            |      |        |
|                                | <b>Standard Parameters</b> |      |        |
|                                |                            |      |        |
| Back                           |                            | Home |        |

5. Push  or  to select [Backup (drive → keypad)], then push .

|                       |                                |      |        |
|-----------------------|--------------------------------|------|--------|
| 10:00 am              | FWD                            |      | Backup |
| Select Desired Action |                                |      |        |
|                       | <b>Backup (drive → keypad)</b> |      |        |
|                       | Restore (keypad → drive)       |      |        |
|                       | Verify (check for mismatch)    |      |        |
|                       | Erase (backup data of keypad)  |      |        |
| Back                  |                                | Home |        |

6. Push  or  to select a memory location, then push .

|                                |         |        |
|--------------------------------|---------|--------|
| 10:00 am                       | FWD     | Backup |
| Select Backup/Restore Location |         |        |
| #1                             | No Data | ▶      |
| #2                             | No Data |        |
| #3                             | No Data |        |
| #4                             | No Data |        |
| Back                           |         | Home   |


The keypad shows “End” when the backup procedure completes successfully.

## ◆ Write Backed-up Parameters to the Drive




You can back up parameters on the keypad and write them to different drives.

**Note:**

- Always stop the drive before you start to restore the parameter backups.
- The drive rejects Run commands while it is restoring parameters.

1. Push  (Home) to show the HOME screen.

**Note:**




- When the drive is in HOME Mode, the screen shows [Home] in the upper right-hand corner of the screen.
- If the screen does not show [Home] for , push  (Back), and then push  to show [Home].

2. Push  (Menu).

|                     |     |     |      |
|---------------------|-----|-----|------|
| 10:00 am            | FWD | Rdy | Home |
| Freq Reference (AI) |     |     |      |
| U1-01               | Hz  |     | 0.00 |
| Output Frequency    |     |     |      |
| U1-02               | Hz  |     | 0.00 |
| Output Current      |     |     |      |
| U1-03               | A   |     | 0.00 |
| Menu                |     |     |      |

3. Push  or  to select [Parameter Backup/Restore], then push .

|                            |     |      |
|----------------------------|-----|------|
| 10:00 am                   | FWD | Menu |
| Monitors                   |     |      |
| Parameters                 |     |      |
| User Custom Parameters     |     |      |
| Parameter Backup/Restore   |     | ▶    |
| Modified Param / Fault Log |     |      |
| Auto-Tuning                |     |      |
| Home                       |     |      |

4. Push  or  to select the item to restore, then push .

|                                |     |        |
|--------------------------------|-----|--------|
| 10:00 am                       | FWD | Backup |
| Select Items to Backup/Restore |     |        |
| Standard Parameters ▶          |     |        |
|                                |     |        |
| Back                           |     | Home   |

5. Push  or  to select [Restore (keypad → drive)], then push .

|                               |     |        |
|-------------------------------|-----|--------|
| 10:00 am                      | FWD | Backup |
| Select Desired Action         |     |        |
| Backup (drive → keypad) ----- |     |        |
| Restore (keypad → drive) ▶    |     |        |
| Verify (check for mismatch)   |     |        |
| Erase (backup data of keypad) |     |        |
| Back                          |     | Home   |

### 3.4 Keypad Operation

6. Push or to select the backed-up parameter data, then push .

|                                |                  |        |
|--------------------------------|------------------|--------|
| 10:00 am                       | FWD              | Backup |
| Select Backup/Restore Location |                  |        |
| #1                             | 2016/01/01 13:00 | 0-62   |
| #2                             | No Data          |        |
| #3                             | No Data          |        |
| #4                             | No Data          |        |
| Back                           |                  | Home   |

The keypad will show the “End” message when the write process is complete.

**Note:**

Different settings and conditions will change the keypad display.

|      |                                |                    |        |   |
|------|--------------------------------|--------------------|--------|---|
|      |                                | A                  | B      | C |
|      | 10:00 am                       | FWD                | Backup |   |
|      | Select Backup/Restore Location |                    |        |   |
| F    | #1                             | 2016/01/01 14:10   | 0-62   | * |
|      | #2                             | 2016/01/01 02:10pm | 1-62   | * |
| E    | #3                             | ---/--/-- --:--    | 2-62   | * |
| D    | #4                             | No Data            |        |   |
| Back |                                | Home               |        |   |

- A - A1-02 [Control Method Selection] settings
- B - o2-04 [Drive Model (KVA) Selection] settings (2 or 3 digits)
- C - Presence of DriveWorksEZ parameter backup
- D - Parameter backup data is not registered
- E - Backup data does not contain the date information
- F - Backup date

### ◆ Verify Keypad Parameters and Drive Parameters

This procedure verifies that the parameter setting values that were backed up in the keypad agree with the parameter setting values in the drive.

**Note:**

- Always stop the drive before you start to verify the parameters.
- The drive does not accept Run commands while restoring parameters.

1. Push (Home) to show the HOME screen.

**Note:**




- When the drive is in HOME Mode, the screen shows [Home] in the upper right-hand corner of the screen.
- If the screen does not show [Home] for , push (Back), and then push to show [Home].

2. Push (Menu).

|                     |     |     |      |
|---------------------|-----|-----|------|
| 10:00 am            | FWD | Rdy | Home |
| Freq Reference (AI) |     |     |      |
| U1-01               | Hz  |     | 0.00 |
| Output Frequency    |     |     |      |
| U1-02               | Hz  |     | 0.00 |
| Output Current      |     |     |      |
| U1-03               | A   |     | 0.00 |
| Menu                |     |     |      |

3. Push or to select [Parameter Backup/Restore], then push .




|          |                            |      |
|----------|----------------------------|------|
| 10:00 am | FWD                        | Menu |
|          | Monitors                   |      |
|          | Parameters                 |      |
|          | User Custom Parameters     |      |
|          | Parameter Backup/Restore   |      |
|          | Modified Param / Fault Log |      |
|          | Auto-Tuning                |      |
| Home     |                            |      |

4. Push  or  to select the item to verify, then push .

|                                |     |        |
|--------------------------------|-----|--------|
| 10:00 am                       | FWD | Backup |
| Select Items to Backup/Restore |     |        |
| Standard Parameters ▶          |     |        |
|                                |     |        |
| Back Home                      |     |        |

5. Push  or  to select [Verify (drive → keypad)], then push .

|                               |     |        |
|-------------------------------|-----|--------|
| 10:00 am                      | FWD | Backup |
| Select desired action.        |     |        |
| Backup (drive → keypad)       |     |        |
| Restore (keypad → drive)      |     |        |
| Verify (check for mismatch) ▶ |     |        |
| Erase (backup data of keypad) |     |        |
| Back Home                     |     |        |

6. Push  or  to select the data to verify, then push .

|                                |     |        |
|--------------------------------|-----|--------|
| 10:00 am                       | FWD | Backup |
| Select Backup/Restore Location |     |        |
| #1 2016/01/01 13:00 0-62 ▶     |     |        |
| #2 No Data                     |     |        |
| #3 No Data                     |     |        |
| #4 No Data                     |     |        |
| Back Home                      |     |        |


The keypad shows “End” when the parameter settings backed up in the keypad agree with the parameter settings copied to the drive.

**Note:**




The keypad shows *vFyE [Parameters do not Match]* when the parameter settings backed up in the keypad do not agree with the parameter settings copied to the drive. Push one of the keys to return to the screen in Step 6.

### ◆ Delete Parameters Backed Up to the Keypad

This procedure deletes the parameters that were backed up to the keypad.

1. Push  (Home) to show the HOME screen.

**Note:**







- When the drive is in HOME Mode, the screen shows [Home] in the upper right-hand corner of the screen.
- If the screen does not show [Home] for , push  (Back), and then push  to show [Home].




2. Push  (Menu).

|                     |     |     |      |
|---------------------|-----|-----|------|
| 10:00 am            | FWD | Rdy | Home |
| Freq Reference (AI) |     |     |      |
| U1-01               | Hz  |     | 0.00 |
| Output Frequency    |     |     |      |
| U1-02               | Hz  |     | 0.00 |
| Output Current      |     |     |      |
| U1-03               | A   |     | 0.00 |
| Menu                |     |     |      |

### 3.4 Keypad Operation

3. Push  or  to select [Parameter Backup/Restore], then push .




|   |                                 |      |
|---|---------------------------------|------|
| 10:00 am  | FWD                             | Menu |
|  | Monitors                        |      |
|  | Parameters                      |      |
|  | User Custom Parameters          |      |
|  | <b>Parameter Backup/Restore</b> | ▶    |
|  | Modified Param / Fault Log      |      |
|  | Auto-Tuning                     |      |
| Home  |                                 |      |

4. Push  or  to select the item to verify, then push .

|                                |     |        |
|--------------------------------|-----|--------|
| 10:00 am                       | FWD | Backup |
| Select Items to Backup/Restore |     |        |
| <b>Standard Parameters</b> ▶   |     |        |
|                                |     |        |
| Back                           |     | Home   |

5. Push  or  to select [Delete (keypad)], then push .

|  |     |        |
|--|-----|--------|
| 10:00 am                               | FWD | Backup |
| Select desired action.                 |     |        |
| -----                                  |     |        |
| Backup (drive → keypad)                |     |        |
| Restore (keypad → drive)               |     |        |
| Verify (check for mismatch)            |     |        |
| <b>Erase (backup data of keypad)</b> ▶ |     |        |
|  |     |        |
| Back                                   |     | Home   |


6. Push  or  to select the data to delete, then push .

|                                |                    |        |
|--------------------------------|--------------------|--------|
| 10:00 am                       | FWD                | Backup |
| Select Backup/Restore Location |                    |        |
| #1                             | 2016/01/01 14:10   | 0-62   |
| #2                             | 2016/01/01 02:10pm | 1-62   |
| #3                             | ---/--/-- --:--    | 2-62   |
| #4                             | No Data            |        |
| Back                           |                    | Home   |




The keypad will show the “End” message when the write process is complete.

#### ◆ Check Modified Parameters

This procedure will show all parameters that were changed from their defaults as the result of Auto-Tuning or setting changes. This helps find which settings have been changed, and is very useful when you replace a drive. This lets users quickly access and re-edit changed parameters. If no parameters have been changed, the keypad will show “0 Parameters”.

1. Push  (Home) to show the HOME screen.

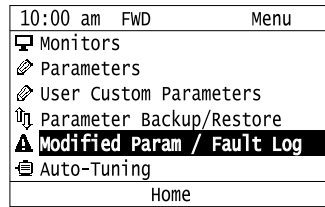
**Note:**

- The keypad will show [Home] in the top right corner when the HOME screen is active.
- If [Home] is not shown on , push  (Back) to show [Home] on .

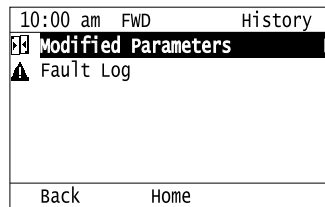
2. Push  (Menu).

|                     |     |     |      |
|---------------------|-----|-----|------|
| 10:00 am            | FWD | Rdy | Home |
| Freq Reference (AI) |     |     |      |
| U1-01               | Hz  |     | 0.00 |
| Output Frequency    |     |     |      |
| U1-02               | Hz  |     | 0.00 |
| Output Current      |     |     |      |
| U1-03               | A   |     | 0.00 |
| Menu                |     |     |      |

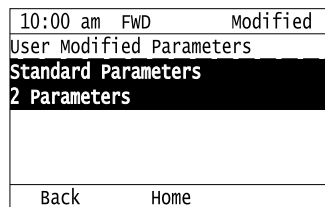
3. Push or to select [Modified Param / Fault Log], then push .



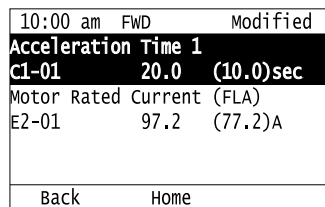
4. Push or to select [Modified Parameters], then push .



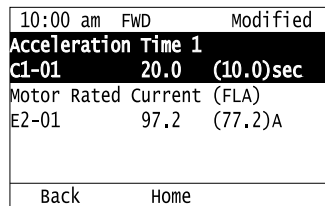
5. Push .



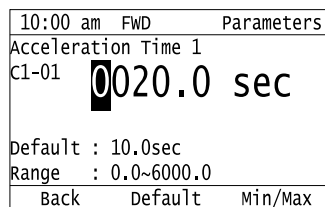
6. Push or to show the parameter to check.




7. To re-edit a parameter, push or , select the parameter to edit, then push .



8. Push or to select the digit, then push or to change the value.



### 3.4 Keypad Operation


9. When you are done changing the value, push .

|                     |         |            |
|---------------------|---------|------------|
| 10:00 am            | FWD     | Parameters |
| Acceleration Time 1 |         |            |
| C1-01               | 0030.0  | sec        |
| Default : 10.0sec   |         |            |
| Range : 0.0~6000.0  |         |            |
| Back                | Default | Min/Max    |




The parameter revision procedure is complete.

#### ◆ Restore Modified Parameters to Defaults

This procedure will set all parameters with changed values to their default settings.

1. Push  (Home) to show the HOME screen.

**Note:**

- The keypad will show [Home] in the top right corner when the HOME screen is active.
- If [Home] is not shown on , push  (Back) to show [Home] on .

2. Push  (Menu).

|                     |     |      |      |
|---------------------|-----|------|------|
| 10:00 am            | FWD | Rdy  | Home |
| Freq Reference (AI) |     |      |      |
| U1-01               | Hz  | 0.00 |      |
| Output Frequency    |     |      |      |
| U1-02               | Hz  | 0.00 |      |
| Output Current      |     |      |      |
| U1-03               | A   | 0.00 |      |
| Menu                |     |      |      |

3. Push  or  to select [Modified Param / Fault Log], then push .

|                            |     |      |
|----------------------------|-----|------|
| 10:00 am                   | FWD | Menu |
| Monitors                   |     |      |
| Parameters                 |     |      |
| User Custom Parameters     |     |      |
| Parameter Backup/Restore   |     |      |
| Modified Param / Fault Log |     |      |
| Auto-Tuning                |     |      |
| Home                       |     |      |




4. Push  or  to select [Modified Parameters], then push .

|                     |     |         |
|---------------------|-----|---------|
| 10:00 am            | FWD | History |
| Modified Parameters |     |         |
| Fault Log           |     |         |
| Back                |     |         |
| Home                |     |         |

5. Push .

|                          |     |          |
|--------------------------|-----|----------|
| 10:00 am                 | FWD | Modified |
| User Modified Parameters |     |          |
| Standard Parameters      |     |          |
| 2 Parameters             |     |          |
| Back                     |     |          |
| Home                     |     |          |



6. Push  or  to select the parameters to return to their default settings, then push .

|                           |      |           |
|---------------------------|------|-----------|
| 10:00 am                  | FWD  | Modified  |
| Acceleration Time 1       |      |           |
| C1-01                     | 20.0 | (10.0)sec |
| Motor Rated Current (FLA) |      |           |
| E2-01                     | 97.2 | (77.2)A   |
| Back Home                 |      |           |

7. Push  (Default).

|                      |        |            |
|----------------------|--------|------------|
| 10:00 am             | FWD    | Parameters |
| Acceleration Time 1  |        |            |
| C1-01                | 0020.0 | sec        |
| Default : 10.0sec    |        |            |
| Range : 0.0~6000.0   |        |            |
| Back Default Min/Max |        |            |

8. Push .

|                      |        |            |
|----------------------|--------|------------|
| 10:00 am             | FWD    | Parameters |
| Acceleration Time 1  |        |            |
| C1-01                | 0010.0 | sec        |
| Default : 10.0sec    |        |            |
| Range : 0.0~6000.0   |        |            |
| Back Default Min/Max |        |            |


The modified parameters are now set to default values.

### ◆ Show Fault History




You can examine a maximum of 10 fault codes and dates and times that the faults occurred.

**Note:**

- Make sure that you first set the date and time on the keypad if you will monitor the date and time of the faults.
- If the keypad does not have a clock battery, you must set the date and time each time you energize the drive.

1. Push  (Home) to show the HOME screen.

**Note:**

- The keypad will show [Home] in the top right corner when the HOME screen is active.
- If [Home] is not shown on , push  (Back) to show [Home] on .

2. Push  (Menu).

|                     |     |     |      |
|---------------------|-----|-----|------|
| 10:00 am            | FWD | Rdy | Home |
| Freq Reference (AI) |     |     |      |
| U1-01               | Hz  |     | 0.00 |
| Output Frequency    |     |     |      |
| U1-02               | Hz  |     | 0.00 |
| Output Current      |     |     |      |
| U1-03               | A   |     | 0.00 |
| Menu                |     |     |      |



3. Push  or  to select [Modified Parameters/Fault History], then push .

|                                |     |      |
|--------------------------------|-----|------|
| 10:00 am                       | FWD | Menu |
| Monitors                       |     |      |
| Parameters                     |     |      |
| User Custom Parameters         |     |      |
| Parameter Backup/Restore       |     |      |
| ▲ Modified Param / Fault Log ▶ |     |      |
| Auto-Tuning                    |     |      |
| Home                           |     |      |

### 3.4 Keypad Operation

4. Push  or  to select [Fault History], then push .

|                     |     |         |
|---------------------|-----|---------|
| 10:00 am            | FWD | History |
| Modified Parameters |     |         |
| ▲ Fault Log ▶       |     |         |
| Back Home           |     |         |

5. Push  or  to show the fault history you will examine.

|                   |                  |             |
|-------------------|------------------|-------------|
| 10:00 am          | FWD              | History     |
| Fault History Log |                  |             |
| 01 ov             | 2016/01/01 14:00 | Overvoltage |
| 02 oc             | 2016/01/01 14:00 | Overcurrent |
| Back Home         |                  |             |

### ◆ Auto-Tuning the Drive

Auto-Tuning uses motor characteristics to automatically set drive parameters.

Refer to the motor nameplate or the motor test report for the necessary information for Auto-Tuning.

|                                |               |    |          |       |             |                |       |  |  |
|--------------------------------|---------------|----|----------|-------|-------------|----------------|-------|--|--|
| VARTSPEED                      |               |    |          |       |             |                |       |  |  |
| 3-PHASE PERMANENT MAGNET MOTOR |               |    |          |       |             |                |       |  |  |
| TYPE SST4-                     |               |    |          |       | POLES E5-04 |                |       |  |  |
| PROTECTION                     |               |    |          |       | COOLING     |                |       |  |  |
| kw                             | V             | Hz | RATING   | A     | r/min       | r <sub>i</sub> | E5-05 |  |  |
| E5-02                          | E1-05         |    |          | E5-03 | E1-04,06    | Ld             | E5-06 |  |  |
|                                |               |    |          |       |             | Lq             | E5-07 |  |  |
|                                |               |    |          |       |             | Ke             | E5-09 |  |  |
| TNS.                           | COOLANT TEMP. | °C | ALTITUDE | m     | Δθ          | E5-11          |       |  |  |
| STD                            |               |    | MASS     | kg    | Δθ'         |                |       |  |  |
| BRG NO                         | DRIVE         |    | OPP      |       | Ki          |                |       |  |  |
| END                            |               |    | END      |       | Kt          |                |       |  |  |
| SER NO                         |               |    | YEAR     |       | Kt          |                |       |  |  |
| YASKAWA ELECTRIC CORPORATION   |               |    |          |       | JAPAN       | Si             |       |  |  |


Figure 3.8 Motor Nameplate (Example)

**WARNING!** Sudden Movement Hazard. Before you do Auto-Tuning, remove all personnel and objects from the area around the drive, motor, and load. The drive and motor can start suddenly during Auto-Tuning and cause serious injury or death.




**WARNING!** Electrical Shock Hazard. During Auto-Tuning, the motor will receive high voltage when the motor is stopped. Do not touch the motor until Auto-Tuning is complete. If you touch a motor that is energized, it can cause serious injury or death.

**WARNING!** Before you do Rotational Auto-Tuning, disconnect the load from the motor. The load can move suddenly and cause serious injury or death.

This procedure shows how to do Rotational Auto-Tuning.

1. Push  (Home) to show the HOME screen.

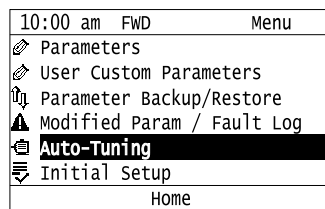
**Note:**

- When the drive is in HOME Mode, the screen shows [Home] in the upper right-hand corner of the screen.
- If the screen does not show [Home] for , push  (Back), and then push  to show [Home].

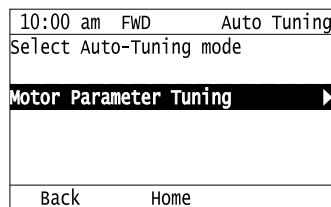
2. Push  (Menu).

|                     |     |     |      |
|---------------------|-----|-----|------|
| 10:00 am            | FWD | Rdy | Home |
| Freq Reference (AI) |     |     |      |
| U1-01               | Hz  |     | 0.00 |
| Output Frequency    |     |     |      |
| U1-02               | Hz  |     | 0.00 |
| Output Current      |     |     |      |
| U1-03               | A   |     | 0.00 |
| Menu                |     |     |      |

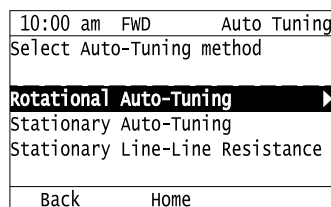
3. Push  or  to select [Auto-Tuning], then push .








4. Push .

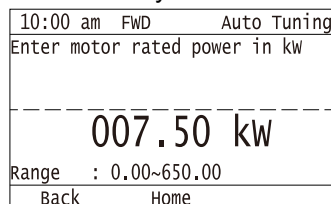


5. Push  or  to select [Rotational Auto-Tuning], then push .



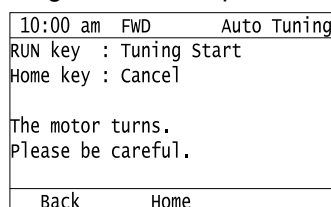
6. Follow the messages shown on the keypad to input the necessary Auto-Tuning data.

Example: Push  or  to select the specified digit, then push  or  to change the number. Push  to save the change and move to the next entry field.



7. Follow the messages shown on the keypad to do the next steps.



8. When the keypad shows the Auto-Tuning start screen, push .

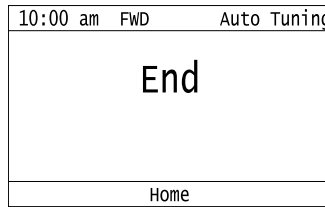


Auto-Tuning starts.




When doing Rotational Auto-Tuning, the motor will stay stopped for approximately one minute with power energized and then the motor will start to rotate.

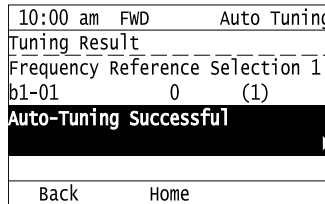
### 3.4 Keypad Operation




9. When the keypad shows this screen after Auto-Tuning is complete for 1 or 2 minutes, push  or .



The keypad will show a list of the changed parameters as the result of Auto-Tuning.


10. Push  or  in the parameter change confirmation screen to check the changed parameters, then select [Auto-Tuning Successful] at the bottom of the screen and push .

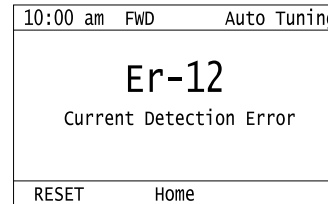
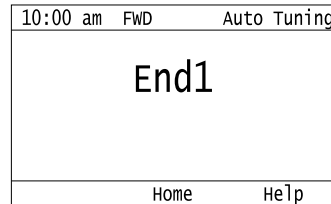


To change a parameter again, push  or  to select the parameter to change, then push  to show the parameter setting screen.

Auto-Tuning is complete.


**Note:**

If the drive detects an error or you push  before Auto-Tuning is complete, Auto-Tuning will stop and the keypad will show an error code. *Endx* identifies that Auto-Tuning was successful with calculation errors. Find and repair the cause of the error and do Auto-Tuning again, or set the motor parameters manually. You can use the drive in the application if you cannot find the cause of the *Endx* error. *Er-xx* identifies that Auto-Tuning was not successful. Find and repair the cause of the error and do Auto-Tuning again.






### ◆ Set the Keypad Language Display

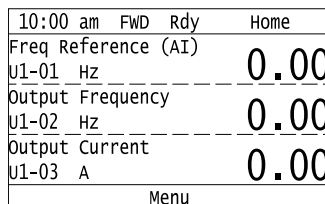
The procedure in this section shows how to set the language shown on the keypad.




1. Push  (Home) to show the HOME screen.








**Note:**

- The keypad will show [Home] in the top right corner when the HOME screen is active.
- If [Home] is not shown on , push  (Back), to show [Home] on .






2. Push  (Menu).






3. Push  or  to select [Initial Settings], then push .

|   |                            |   |
|---|----------------------------|---|
| 10:00 am  | FWD                        | Menu  |
|  | User Custom Parameters     |   |
|  | Parameter Backup/Restore   |   |
|  | Modified Param / Fault Log |   |
|  | Auto-Tuning                |   |
|  | <b>Initial Setup</b>       |  |
|  | Diagnostic Tools           |   |
| Home  |                            |   |

4. Push  or  to select [Language Selection], then push .

|   |                           |   |
|---|---------------------------|---|
| 10:00 am  | FWD                       | Init Setup  |
|  | <b>Language Selection</b> |  |
|  | Set Date/Time             |   |
|  | Setup Wizard              |   |
|  | Show Initial Setup Screen |   |
| Back Home   |                           |   |

5. Push  or  to select the language, then push .

|                    |     |            |
|--------------------|-----|------------|
| 10:00 am           | FWD | Init Setup |
| Language Selection |     |            |
| <b>English</b>     |     |            |
| Japanese           |     |            |
| Deutsch            |     |            |
| Frangais           |     |            |
| Italiano           |     |            |
| Back Home          |     |            |


The procedure to set the keypad language is complete.

## ◆ Set the Date and Time




The procedure in this section shows how to set the date and time.

### Note:

- Refer to **Missing reference ID** for information about the battery installation procedure.  
To set the drive to detect an alarm when the battery is dead or when the clock is not set, install the battery then set  $o4-24 = 1$  [*bAT Detection selection = Enable (Alarm Detected)*].
- If the keypad does not have a clock battery, you must set the date and time each time you energize the drive.

- Push  (Home) to show the HOME screen.

### Note:

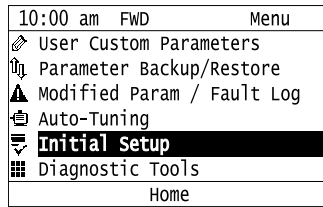
- The keypad will show [Home] in the top right corner when the HOME screen is active.
- If [Home] is not shown on , push  (Back) to show [Home] on .




- Push  (Menu).

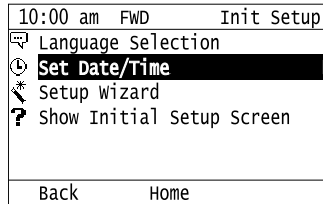
|                     |     |     |      |
|---------------------|-----|-----|------|
| 10:00 am            | FWD | Rdy | Home |
| Freq Reference (AI) |     |     |      |
| U1-01               | Hz  |     | 0.00 |
| Output Frequency    |     |     |      |
| U1-02               | Hz  |     | 0.00 |
| Output Current      |     |     |      |
| U1-03               | A   |     | 0.00 |
| Menu                |     |     |      |




### 3.4 Keypad Operation

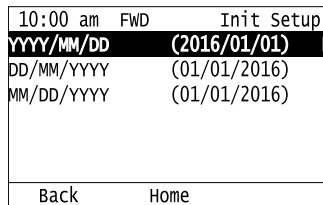
3. Push  or  to select [Initial Setup], then push .






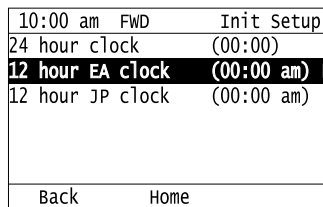
4. Push  or  to select [Set Date/Time], and push .



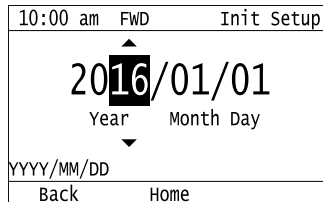
5. Push  or  to select the format of date display, then push .




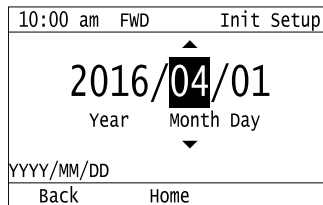
6. Push  or  to select the format of time display, then push .







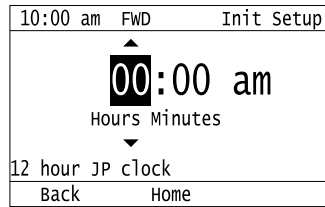
7. Push  or  to select a number from Year/Month/Day, then push  or  to change the value.




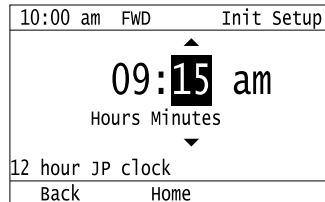
8. When you are done changing the value, push .



9. Push  or  to select the hour or minute, then push  or  to change the value.



10. When you are done setting the time, push .



The procedure for setting the date and time is complete.


### ◆ Set Parameters Using the Setup Wizard

The Setup Wizard lets users follow simple messages on the keypad to set these basic parameters:




- Frequency reference source
- Input signal level
- Run command source
- Duty Rating
- Motor type
- Control method
- Maximum frequency
- Input/output settings

**Note:**

The Setup Wizard function will initialize all parameters before it sets the basic parameters.

1. Push  (Home) to show the HOME screen.







**Note:**

- The keypad will show [Home] in the top right corner when the HOME screen is active.
- If [Home] is not shown on , push  (Back) to show [Home] on .




2. Push  (Menu).





|                     |      |
|---------------------|------|
| 10:00 am FWD Rdy    | Home |
| Freq Reference (AI) | 0.00 |
| U1-01 Hz            | 0.00 |
| Output Frequency    | 0.00 |
| U1-02 Hz            | 0.00 |
| Output Current      | 0.00 |
| U1-03 A             | 0.00 |
| Menu                |      |




3. Push  or  to select [Initial Setup], then push .

|  |      |
|--|------|
| 10:00 am FWD   | Menu |
|  User Custom Parameters     |      |
|  Parameter Backup/Restore   |      |
|  Modified Param / Fault Log |      |
|  Auto-Tuning                |      |
|  <b>Initial Setup</b>       |      |
|  Diagnostic Tools           |      |
| Home   |      |

### 3.4 Keypad Operation

4. Push  or  to select [Setup Wizard], then push .




|   |                           |            |
|---|---------------------------|------------|
| 10:00 am  | FWD                       | Init Setup |
|  | Language Selection        |            |
|  | Set Date/Time             |            |
|  | <b>Setup Wizard</b>       |            |
|  | Show Initial Setup Screen |            |
| Back  |                           | Home       |

5. Push  or  to select [Yes], then push .

**Note:**

This operation will initialize all parameters.




|  |     |        |
|--|-----|--------|
| 10:00 am   | FWD | wizard |
| An initialization will be performed prior to continuing with the Setup wizard. |     |        |
| -----  |     |        |
| <b>No</b>  |     |        |
| Yes  |     |        |
| Back   |     | Home   |

6. Push  or  to select the item to set, then push .

|                               |     |        |
|-------------------------------|-----|--------|
| 10:00 am                      | FWD | wizard |
| Select speed reference source |     |        |
| <b>Keypad</b>                 |     |        |
| Analog Input                  |     |        |
| Memobus/Modbus Communications |     |        |
| Option PCB                    |     |        |
| Back                          |     | Home   |




7. For the next steps, follow the instructions shown on the keypad until the “Parameter Change Confirmation Screen” is shown.

|                                 |     |        |
|---------------------------------|-----|--------|
| 10:00 am                        | FWD | wizard |
| Pending Parameter Changes       |     |        |
| <b>Control Method Selection</b> |     |        |
| A1-02                           | 0   | (2)    |
| Frequency Reference Selection 1 |     |        |
| b1-01                           | 0   | (1)    |
| Back                            |     | Home   |




8. In the parameter change confirmation screen, push  or  to examine the changed parameter, then select [Apply of each parameter] at the bottom of the screen and push .

|                                 |     |        |
|---------------------------------|-----|--------|
| 10:00 am                        | FWD | wizard |
| Pending Parameter Changes       |     |        |
| Frequency Reference Selection 1 |     |        |
| b1-01                           | 0   | (1)    |
| <b>Apply Parameter Changes</b>  |     |        |
| Back                            |     | Home   |

**Note:**

To change a parameter again, push  or  to select the parameter to change, then push  to show the parameter setting screen.




9. Push  or  to select [Yes], then push .

|  |      |        |
|--|------|--------|
| 10:00 am                                   | FWD  | Wizard |
| Should the parameter settings be applied ? |      |        |
| No   |      |        |
| Yes  |      |        |
| Back                                       | Home |        |




The Setup Wizard procedure is complete.

### ◆ Disable the Initial Setup Screen

Do the steps in this procedure to not show the initial start-up screen when the drive is energized.

1. Push  (Home) to show the HOME screen.

**Note:**




- When the drive is in HOME Mode, the screen shows [Home] in the upper right-hand corner of the screen.
- If the screen does not show [Home] for , push  (Back), and then push  to show [Home].

2. Push  (Menu).




|                     |     |      |      |
|---------------------|-----|------|------|
| 10:00 am            | FWD | Rdy  | Home |
| Freq Reference (AI) |     |      |      |
| U1-01               | Hz  | 0.00 |      |
| Output Frequency    |     |      |      |
| U1-02               | Hz  | 0.00 |      |
| Output Current      |     |      |      |
| U1-03               | A   | 0.00 |      |
| Menu                |     |      |      |

3. Push  /  to select [Initial Setup], then push .

|                            |     |      |
|----------------------------|-----|------|
| 10:00 am                   | FWD | Menu |
| User Custom Parameters     |     |      |
| Parameter Backup/Restore   |     |      |
| Modified Param / Fault Log |     |      |
| Auto-Tuning                |     |      |
| Initial Setup              |     |      |
| Diagnostic Tools           |     |      |
| Home                       |     |      |

4. Push  /  to select [Show Initial Setup Screen], then push .

|                           |     |            |
|---------------------------|-----|------------|
| 10:00 am                  | FWD | Init Setup |
| Language Selection        |     |            |
| Set Date/Time             |     |            |
| Setup Wizard              |     |            |
| Show Initial Setup Screen |     |            |
| Back                      |     |            |
| Home                      |     |            |

5. Push  /  to select [No], then push .

|                           |     |            |
|---------------------------|-----|------------|
| 10:00 am                  | FWD | Init Setup |
| Show Initial Setup Screen |     |            |
| No                        |     |            |
| Yes                       |     |            |
| Back                      |     |            |
| Home                      |     |            |

- [No]: The keypad will not show the Initial Setup Screen when the drive is energized.
- [Yes]: The keypad will show the Initial Setup Screen when the drive is energized.

### ◆ Start Data Logging

The data log function saves drive status information. Monitors *Ux-xx* are the source of log information. The procedure in this section shows how to start logging data.

You can record a maximum of 10 monitors.

1. Make sure that a microSD card is inserted in the keypad.
2. Push **F2** (Home) to show the HOME screen.

**Note:**

- When the drive is in HOME Mode, the screen shows [Home] in the upper right-hand corner of the screen.
- If the screen does not show [Home] for **F2**, push **F1** (Back), and then push **F2** to show [Home].

3. Push **F2** (Menu).

|                     |      |
|---------------------|------|
| 10:00 am FWD Rdy    | Home |
| Freq Reference (AI) |      |
| U1-01 Hz            | 0.00 |
| Output Frequency    |      |
| U1-02 Hz            | 0.00 |
| Output Current      |      |
| U1-03 A             | 0.00 |
| Menu                |      |

4. Push **▲** or **▼** to select [Diagnostic Tools], then push **↵**.

|                              |      |
|------------------------------|------|
| 10:00 am FWD                 | Menu |
| ⚙ User Custom Parameters     |      |
| 🔄 Parameter Backup/Restore   |      |
| ⚠ Modified Param / Fault Log |      |
| 🔧 Auto-Tuning                |      |
| ⚙ Initial Setup              |      |
| 🔧 <b>Diagnostic Tools</b>    | ▶    |
| Home                         |      |

5. Push **▲** or **▼** to select [Data Logger], then push **↵**.

|                    |       |
|--------------------|-------|
| 10:00 am FWD       | Tools |
| <b>Data Logger</b> | ▶     |
| Backlight          |       |
| Drive Information  |       |
| Back Home Setup    |       |

6. Push **▲** or **▼** to select [Yes] or [No], then push **↵**.

|                     |       |
|---------------------|-------|
| 10:00 am FWD        | Tools |
| Begin Data Logging? |       |
| <b>No</b>           | ▶     |
| Yes                 |       |
| Back Home           |       |

- [Yes]: Data logging starts.
- [No]: Data logging will not start.

If the drive was logging data when you entered the command, the keypad look like this:

|                               |       |
|-------------------------------|-------|
| 10:00 am FWD                  | Tools |
| End Data Logging?             |       |
| <b>No</b>                     | ▶     |
| Yes                           |       |
| Start Time : 2016/01/01 00:00 |       |
| Period : 00:10:00             |       |
| Back Home                     |       |

## ◆ Configuring the Data Log Content

### ■ Set Monitor to Log

The procedure in this section shows how to set the monitor for which to log data.




1. Push **F2** (Home) to show the HOME screen.

**Note:**


- When the drive is in HOME Mode, the screen shows [Home] in the upper right-hand corner of the screen.
- If the screen does not show [Home] for **F2**, push **F1** (Back), and then push **F2** to show [Home].

2. Push **F2** (Menu).

|                     |         |      |
|---------------------|---------|------|
| 10:00 am            | FWD Rdy | Home |
| Freq Reference (AI) |         |      |
| U1-01               | Hz      | 0.00 |
| Output Frequency    |         |      |
| U1-02               | Hz      | 0.00 |
| Output Current      |         |      |
| U1-03               | A       | 0.00 |
| Menu                |         |      |

3. Push  or  to select [Diagnostic Tools], then push .

|                            |     |      |
|----------------------------|-----|------|
| 10:00 am                   | FWD | Menu |
| User Custom Parameters     |     |      |
| Parameter Backup/Restore   |     |      |
| Modified Param / Fault Log |     |      |
| Auto-Tuning                |     |      |
| Initial Setup              |     |      |
| <b>Diagnostic Tools</b>    |     |      |
| Home                       |     |      |

4. Push  or  to select [Data Logger], then push **F3** (Setup).

|                    |      |       |
|--------------------|------|-------|
| 10:00 am           | FWD  | Tools |
| <b>Data Logger</b> |      |       |
| Backlight          |      |       |
| Drive Information  |      |       |
| Back               | Home | Setup |

5. Push  or  to select [Log Monitor], then push .

|                       |      |       |
|-----------------------|------|-------|
| 10:00 am              | FWD  | Setup |
| <b>Log Monitor</b>    |      |       |
| Log Sampling Interval |      |       |
| Back                  | Home |       |

6. Push  or  to select the save-destination monitor parameter, then push .

|                           |      |       |
|---------------------------|------|-------|
| 10:00 am                  | FWD  | Setup |
| Log Monitor               |      |       |
| <b>Log Monitor Data 1</b> |      |       |
| o5-03                     | 101  | (101) |
| Log Monitor Data 2        |      |       |
| o5-04                     | 102  | (102) |
| Back                      | Home |       |

### 3.4 Keypad Operation


7. Push  or  to select the monitor number to be logged, then push .

|                    |         |            |
|--------------------|---------|------------|
| 10:00 am           | FWD     | Parameters |
| Log Monitor Data 1 |         |            |
| 05-03              |         | <b>101</b> |
| Freq Reference     |         |            |
| Default : 101      |         |            |
| Back               | Default |            |




The configuration procedure is complete.

#### ■ Set the Sampling Time

The procedure in this section shows how to set the sampling time for data logging.

1. Push  (Home) to show the HOME screen.

**Note:**

- When the drive is in HOME Mode, the screen shows [Home] in the upper right-hand corner of the screen.
- If the screen does not show [Home] for , push  (Back), and then push  to show [Home].

2. Push  (Menu).

|                     |     |     |             |
|---------------------|-----|-----|-------------|
| 10:00 am            | FWD | Rdy | Home        |
| Freq Reference (AI) |     |     |             |
| U1-01               | Hz  |     | <b>0.00</b> |
| Output Frequency    |     |     |             |
| U1-02               | Hz  |     | <b>0.00</b> |
| Output Current      |     |     |             |
| U1-03               | A   |     | <b>0.00</b> |
| Menu                |     |     |             |

3. Push  or  to select [Diagnostic Tools], then push .

|                            |     |      |
|----------------------------|-----|------|
| 10:00 am                   | FWD | Menu |
| User Custom Parameters     |     |      |
| Parameter Backup/Restore   |     |      |
| Modified Param / Fault Log |     |      |
| Auto-Tuning                |     |      |
| Initial Setup              |     |      |
| <b>Diagnostic Tools</b>    |     |      |
| Home                       |     |      |

4. Push  or  to select [Data Logger], then push  (Setup).

|                    |      |       |
|--------------------|------|-------|
| 10:00 am           | FWD  | Tools |
| <b>Data Logger</b> |      |       |
| Backlight          |      |       |
| Drive Information  |      |       |
| Back               | Home | Setup |

5. Push  or  to select [Log Sampling Interval], then push .

|                              |      |       |
|------------------------------|------|-------|
| 10:00 am                     | FWD  | Setup |
| Log Monitor                  |      |       |
| <b>Log Sampling Interval</b> |      |       |
| Back                         | Home |       |

6. Push or to select the digit, then push or to change the value.

|                       |          |            |
|-----------------------|----------|------------|
| 10:00 am              | FWD      | Parameters |
| Log Sampling Interval |          |            |
| 05-02                 | <b>0</b> | 1000 ms    |
| Default : 1000ms      |          |            |
| Range : 100~60000     |          |            |
| Back                  | Default  | Min/Max    |

7. When you complete changing the value, push .

|                       |           |            |
|-----------------------|-----------|------------|
| 10:00 am              | FWD       | Parameters |
| Log Sampling Interval |           |            |
| 05-02                 | <b>20</b> | 0000 ms    |
| Default : 1000ms      |           |            |
| Range : 100~60000     |           |            |
| Back                  | Default   | Min/Max    |

The procedure to set the sampling time is complete.

### ◆ Set Backlight to Automatically Turn OFF

You can set the backlight of the keypad screen to automatically turn OFF after a set length of time since the last key operation on the keypad. The procedure in this section shows how to turn ON and turn OFF the backlight.

1. Push (Home) to show the HOME screen.

**Note:**

- The keypad will show [Home] in the top right corner when the HOME screen is active.
- If [Home] is not shown on , push (Back) to show [Home] on .

2. Push (Menu).

|                     |     |     |      |
|---------------------|-----|-----|------|
| 10:00 am            | FWD | Rdy | Home |
| Freq Reference (AI) |     |     |      |
| U1-01               | Hz  |     | 0.00 |
| Output Frequency    |     |     |      |
| U1-02               | Hz  |     | 0.00 |
| Output Current      |     |     |      |
| U1-03               | A   |     | 0.00 |
| Menu                |     |     |      |

3. Push or to select [Diagnostic Tools], then push .

|          |                            |      |
|----------|----------------------------|------|
| 10:00 am | FWD                        | Menu |
|          | User Custom Parameters     |      |
|          | Parameter Backup/Restore   |      |
|          | Modified Param / Fault Log |      |
|          | Auto-Tuning                |      |
|          | Initial Setup              |      |
|          | <b>Diagnostic Tools</b>    |      |
| Home     |                            |      |

4. Push or to select [Backlight], then push .

|                   |      |       |
|-------------------|------|-------|
| 10:00 am          | FWD  | Tools |
| Data Logger       |      |       |
| <b>Backlight</b>  |      |       |
| Drive Information |      |       |
| Back              | Home | Setup |

### 3.4 Keypad Operation

5. Push  or  to select [ON] or [OFF], then push .

|                                |      |       |
|--------------------------------|------|-------|
| 10:00 am                       | FWD  | Tools |
| LCD backlight ON/OFF selection |      |       |
| OFF                            |      |       |
| <b>ON</b>                      |      |       |
|                                |      |       |
| Back                           | Home |       |





- [ON]: Backlight is always ON
- [OFF]: Backlight turns OFF after set length of time.

6. Push  (Setup).


|                   |      |       |
|-------------------|------|-------|
| 10:00 am          | FWD  | Tools |
| Data Logger       |      |       |
| <b>Backlight</b>  |      |       |
| Drive Information |      |       |
|                   |      |       |
| Back              | Home | Setup |

7. Push .

|                                       |      |         |
|---------------------------------------|------|---------|
| 10:00 am                              | FWD  | Setup   |
| Energy Saving                         |      |         |
| <b>Time to turn off LCD backlight</b> |      |         |
| 01-38                                 | 60   | (60)sec |
|                                       |      |         |
| Back                                  | Home |         |

8. Push  or  to select the digit, then push  or  to change the value.

|                                |            |            |
|--------------------------------|------------|------------|
| 10:00 am                       | FWD        | Parameters |
| Time to turn off LCD backlight |            |            |
| 01-38                          | <b>060</b> | sec        |
| Default : 60sec                |            |            |
| Range : 10~300                 |            |            |
| Back                           | Default    | Min/Max    |


9. When you are done changing the value, push .

|                                |            |            |
|--------------------------------|------------|------------|
| 10:00 am                       | FWD        | Parameters |
| Time to turn off LCD backlight |            |            |
| 01-38                          | <b>030</b> | sec        |
| Default : 60sec                |            |            |
| Range : 10~300                 |            |            |
| Back                           | Default    | Min/Max    |




The procedure to set the backlight to turn OFF automatically is complete.

#### ◆ Show Information about the Drive

The procedure in this section shows how to show the drive model, maximum applicable motor output (HD/ND), rated output current (HD/ND), software version, and the serial number on the keypad.

1. Push  (Home) to show the HOME screen.




**Note:**

- The keypad will show [Home] in the top right corner when the HOME screen is active.
- If [Home] is not shown on , push  (Back) to show [Home] on .






### 3.4 Keypad Operation

---

2. Push  or  to select [Yes] and then push .

|   |
|---|
| 10:00 am FWD Backup   |
| Drive and Keypad mismatch.<br>Should the parameters be<br>restored? |
| No  |
| <b>Yes</b>  |
|   |
|   |

3. Push  or  to select [Yes] and then push .

|   |
|---|
| 10:00 am FWD Backup                                     |
| Starting restore.<br>Are you sure you want to<br>start? |
| No  |
| <b>Yes</b>  |
|   |
|   |

The keypad will show the “End” message when the write process is complete.



## 3.5 Auto-Tuning

Auto-Tuning uses motor characteristics to automatically set drive parameters for vector control. Think about the type of motor, drive control method, and the motor installation environment and select the best Auto-Tuning method.

The keypad will show the messages with prompts to input the necessary parameter information. These prompts are specified by the selected Auto-Tuning method and the control method setting in *A1-02*.

**WARNING! Crush Hazard. This seems incorrect. The drive should not take a 60 Hz motor to 90 Hz during tuning. We think this is a translation error. Please confirm it. Increased motor frequency can cause serious injury or death.**

### ◆ Auto-Tuning for Induction Motors

This section gives information about Auto-Tuning for induction motors. Auto-Tuning sets these parameters:

- Motor parameters *E1-xx*, *E2-xx* (*E3-xx*, *E4-xx* for motor 2)
- Speed feedback detection-use *F1-xx* (only with CLV)

**Note:**

Do Stationary Auto-Tuning if you cannot do Rotational Auto-Tuning. There can be large differences between the measured results and the motor characteristics when Auto-Tuning is complete. Examine the parameters for the measured motor characteristics after you do Stationary Auto-Tuning.

**Table 3.4 Types of Auto-Tuning for Induction Motors**

| Mode                     | Parameter Settings | Application Conditions and Benefits  | Applicable Control Method<br>(A1-02 Setting) |               |            |            |             |
|--------------------------|--------------------|--|--|---------------|------------|------------|-------------|
|                          |                    |  | V/f<br>(0)                                   | CL-V/f<br>(1) | OLV<br>(2) | CLV<br>(3) | AOLV<br>(4) |
| Rotational Auto-Tuning   | T1-01 = 0          | <ul style="list-style-type: none"> <li>• When you can decouple the motor and load the motor can rotate freely while Auto-Tuning.</li> <li>• When operating motors that have fixed output characteristics.</li> <li>• When it is necessary to use motors that have high-precision control.</li> <li>• When you cannot decouple the motor and load, but the motor load is less than 30%.</li> </ul>  | x  | x             | x          | x          | x           |
| Stationary Auto-Tuning 1 | T1-01 = 1          | <ul style="list-style-type: none"> <li>• When you cannot decouple the motor and load, but the motor load is more than 30%.</li> <li>• When the information from the motor test report or motor nameplate is not available. With Stationary Auto-Tuning, the energized drive stays stopped for approximately 1 minute. During this time, the drive automatically measures the necessary motor parameters.</li> <li>• When operating the motor with a light load after Auto-Tuning. The drive can automatically calculate the motor parameter settings necessary for torque control. Set <i>T1-12 = 1</i> [Test Mode Selection = Yes] to do a test run after Auto-Tuning.</li> </ul> | -  | -             | x          | x          | x           |
| Line-to-Line Resistance  | T1-01 = 2          | <ul style="list-style-type: none"> <li>• After Auto-Tuning, the wiring distance between the drive and motor changed by 50 m or more.</li> <li>• When the wiring distance is 50 m or more in the V/f Control mode.</li> <li>• When the motor output and drive capacity are different.</li> </ul>  | x  | x             | x          | x          | x           |

### ■ Input Data for Induction Motor Auto-Tuning

To do Auto-Tuning, input data for the items in Table 3.5 that have an "x". Before starting Auto-Tuning, prepare the motor test report or record the information on the motor nameplate as a reference.

### 3.5 Auto-Tuning

**Table 3.5 Input Data for Induction Motor Auto-Tuning**

| Input Data                 | Parameter | Unit              | Auto-Tuning Mode<br>(T1-01 Setting) |                                    |                                |
|----------------------------|-----------|-------------------|-------------------------------------|------------------------------------|--------------------------------|
|                            |           |                   | Rotational Auto-Tuning<br>(0)       | Stationary Auto-Tuning<br>1<br>(1) | Line-to-Line Resistance<br>(2) |
| Motor Rated Power          | T1-02     | kW                | x                                   | x                                  | x                              |
| Motor Rated Voltage        | T1-03     | V                 | x                                   | x                                  | -                              |
| Motor Rated Current        | T1-04     | A                 | x                                   | x                                  | x                              |
| Motor Base Frequency       | T1-05     | Hz                | x                                   | x                                  | -                              |
| Number of Motor Poles      | T1-06     | -                 | x                                   | x                                  | -                              |
| Motor Base Speed           | T1-07     | min <sup>-1</sup> | x                                   | x                                  | -                              |
| Encoder Pulse Count (PPR)  | T1-08     | -                 | o *1                                | o *1                               | -                              |
| Motor No-Load Current      | T1-09     | A                 | -                                   | x                                  | -                              |
| Motor Rated Slip Frequency | T1-10     | Hz                | -                                   | o *2                               | -                              |
| Motor Iron Loss            | T1-11     | W                 | o *3                                | -                                  | -                              |
| Test Mode Selection *4     | T1-12     | -                 | -                                   | o *5                               | -                              |
| No-load voltage            | T1-13     | V                 | o *6                                | o *6                               | -                              |

- \*1 Input this value when  $A1-02 = 3$  [Control Method Selection = Closed Loop Vector].
- \*2 Shows 0 Hz as the default value. If you do not know the Motor Rated Slip Frequency, keep the setting at 0 Hz.
- \*3 Input this value when  $A1-02 = 0$  or  $1$  [Control Method Selection = V/f Control or V/f Control w/ PG].
- \*4 If  $T1-12 = 1$  [Test Mode Selection = Yes], when you run the motor in Drive Mode for the first time after Auto-Tuning, the drive will automatically set  $E2-02$  [Motor Rated Slip] and  $E2-03$  [Motor No-Load Current].
- \*5 Input this value when  $T1-10$  [Motor Rated Slip Frequency] = 0 Hz.
- \*6 Set the same value to No-Load Voltage as  $T1-03$  [Motor Rated Voltage] to get the same characteristics using Yaskawa 1000-Series drives or other legacy models.

### ◆ Auto-Tuning for Motor Parameters for PM Motor

This section gives information about Auto-Tuning for PM motors. Auto-Tuning sets these parameters:

- Motor parameters  $E1-xx$ ,  $E5-xx$
- Speed feedback detection uses  $F1-xx$  (only with CLV/PM)

**Table 3.6 Auto-Tuning for PM Motors**

| Mode  | Parameter Settings | Application Conditions and Benefits  | Applicable Control Method<br>(A1-02 Setting) |                |               |
|---|--------------------|--|--|----------------|---------------|
|   |                    |  | OLV/PM<br>(5)                                | AOLV/PM<br>(6) | CLV/PM<br>(7) |
| PM Motor Parameter Settings                     | T2-01 = 0          | <ul style="list-style-type: none"> <li>• When the information from the motor test report or motor nameplate is available.</li> <li>• Rotational/Stationary Auto-Tuning that energizes the motor is not done. Manually input the necessary motor parameters.</li> </ul>   | x  | x              | x             |
| PM Stationary Auto-Tuning                       | T2-01 = 1          | <ul style="list-style-type: none"> <li>• When the information from the motor test report or motor nameplate is not available.</li> </ul> <p><b>Note:</b><br/>With Stationary Auto-Tuning, the energized drive stays stopped for approximately 1 minute. During this time, the drive automatically measures the necessary motor parameters.</p> | x  | x              | x             |
| PM Stationary Auto-Tuning for Stator Resistance | T2-01 = 2          | <ul style="list-style-type: none"> <li>• After Auto-Tuning, the wiring distance between the drive and motor changed by 50 m or more.</li> <li>• When the motor output and drive capacity are different.</li> </ul>   | x  | x              | x             |

| Mode                                 | Parameter Settings | Application Conditions and Benefits  | Applicable Control Method<br>(A1-02 Setting) |                |               |
|--------------------------------------|--------------------|--|--|----------------|---------------|
|                                      |                    |  | OLV/PM<br>(5)                                | AOLV/PM<br>(6) | CLV/PM<br>(7) |
| Z-Pulse Offset (Pole Position)       | T2-01 = 3          | <ul style="list-style-type: none"> <li>When you do not know the encoder Z-pulse offset.</li> <li>When the encoder was replaced</li> <li>If you have compensated for the deviation from Z phase (<math>\Delta\theta</math>).</li> </ul> <b>Note:</b><br>The motor will rotate slowly while the drive measures the encoder base position.  | -  | -              | x             |
| PM Rotational Auto-Tuning            | T2-01 = 4          | <ul style="list-style-type: none"> <li>When the information from the motor test report or motor nameplate is not available.</li> <li>When you can decouple the motor and load the motor can rotate freely while Auto-Tuning.</li> <li>Values measured during Auto-Tuning are automatically set to the motor parameters.</li> </ul>   | x  | x              | x             |
| High Frequency Injection Auto-Tuning | T2-01 = 5          | <ul style="list-style-type: none"> <li>Automatically determines the control parameters required to set <math>n8-35 = 1</math> [Initial Pole Detection Method = High Frequency Injection] or <math>n8-57 = 1</math> [HFI Overlap Selection = Enabled].</li> <li>Applicable to IPM motors only.</li> <li>Perform tuning with the motor connected to the drive.</li> </ul> <b>Note:</b><br>When you want to set $n8-35 = 1$ or $n8-57 = 1$ , perform High Frequency Injection Auto-Tuning. Configure the drive with the data from the motor nameplate before performing High Frequency Injection Auto-Tuning. High Frequency Injection Auto-Tuning automatically makes adjustments while it is stopped but still energized. | x  | x              | x             |

■ Input Data for PM Motor Auto-Tuning

To do Auto-Tuning, input data for the items in Table 3.7 and Table 3.8 that have an "x". Before starting Auto-Tuning, prepare the motor test report or record the information on the motor nameplate as a reference.

Table 3.7 Input Data for PM Motor Auto-Tuning

| Input Data                     | Parameter | Unit              | Auto-Tuning Mode<br>(T2-01 Setting) |         |         |                                  |      |  |
|--------------------------------|-----------|-------------------|-------------------------------------|---------|---------|----------------------------------|------|--|
|                                |           |                   | PM Motor Parameter Settings<br>(0)  |         |         | PM Stationary Auto-Tuning<br>(1) |      | PM Stationary Auto-Tuning for Stator Resistance<br>(2) |
| Control method selection       | A1-02     | -                 | 5, 6, 7                             | 5       | 6, 7    | 5                                | 6, 7 | 5, 6, 7  |
| PM Motor Code Selection        | T2-02     | -                 | Motor code of Yaskawa motor *1      | FFFF *2 | FFFF *2 | -                                | -    | -  |
| PM Motor Type                  | T2-03     | -                 | -                                   | -       | -       | x                                | x    | -  |
| PM Motor Rated Power           | T2-04     | kW                | -                                   | x       | x       | x                                | x    | -  |
| PM Motor Rated Voltage         | T2-05     | V                 | -                                   | x       | x       | x                                | x    | -  |
| PM Motor Rated Current         | T2-06     | A                 | -                                   | x       | x       | x                                | x    | x  |
| PM Motor Base Frequency        | T2-07     | Hz                | -                                   | x       | -       | x                                | -    | -  |
| Number of PM Motor Poles       | T2-08     | -                 | -                                   | x       | x       | x                                | x    | -  |
| PM Motor Base Speed            | T2-09     | min <sup>-1</sup> | -                                   | -       | x       | -                                | x    | -  |
| PM Motor Stator Resistance     | T2-10     | Ω                 | x                                   | x       | x       | -                                | -    | -  |
| PM Motor d-Axis Inductance     | T2-11     | mH                | x                                   | x       | x       | -                                | -    | -  |
| PM Motor q-Axis Inductance     | T2-12     | mH                | x                                   | x       | x       | -                                | -    | -  |
| Back-EMF Units Selection       | T2-13     | -                 | x                                   | x       | x       | -                                | -    | -  |
| Back-EMF Voltage Constant (Ke) | T2-14     | *3                | x                                   | x       | x       | -                                | -    | -  |
| Pull-In Current Level          | T2-15     | %                 | -                                   | -       | -       | x                                | x    | -  |

Keypad Use and Test Run

### 3.5 Auto-Tuning

| Input Data                             | Parameter | Unit    | Auto-Tuning Mode<br>(T2-01 Setting) |         |         |                                     |      |   |
|--|-----------|---------|-------------------------------------|---------|---------|-------------------------------------|------|---|
|  |           |         | PM Motor Parameter Settings<br>(0)  |         |         | PM Stationary<br>Auto-Tuning<br>(1) |      | PM Stationary Auto-<br>Tuning for Stator<br>Resistance<br>(2) |
| Control method selection               | A1-02     | -       | 5, 6, 7                             | 5       | 6, 7    | 5                                   | 6, 7 | 5, 6, 7   |
| PM Motor Code Selection                | T2-02     | -       | Motor code of Yaskawa<br>motor *1   | FFFF *2 | FFFF *2 | -                                   | -    | -   |
| Encoder Pulse Count (PPR)              | T2-16     | -       | *4                                  | -       | *4      | -                                   | *4   | -   |
| Encoder Z-Pulse Offset for<br>PM Motor | T2-17     | Degrees | *4                                  | -       | *4      | -                                   | *4   | -   |

\*1 Set the motor code for a Yaskawa PM motor.

\*2 Set the motor code to FFFF for a PM motor from a different manufacturer.

\*3 Changes when the value set in T2-13 changes.

\*4 Input this value when A1-02 = 7 [Control Method Selection = PM Closed Loop Vector Control].

**Table 3.8 Input Data for PM Motor Auto-Tuning**

| Input Data                             | Parameter | Unit              | Auto-Tuning Mode<br>(T2-01 Setting)      |                                  |   |   |  |
|--|-----------|-------------------|--|----------------------------------|---|---|--|
|  |           |                   | Z-Pulse Offset (Pole<br>Position)<br>(3) | PM Rotational Auto-Tuning<br>(4) |   |   | High Frequency<br>Injection Auto-<br>Tuning<br>(5) |
| Control method<br>selection            | A1-02     | -                 | 7  | 5                                | 6 | 7 | 5, 6, 7  |
| PM Motor Code<br>Selection             | T2-02     | -                 | -  | -                                | - | - | -  |
| PM Motor Type                          | T2-03     | -                 | -  | x                                | x | x | -  |
| PM Motor Rated Power                   | T2-04     | kW                | -  | x                                | x | x | -  |
| PM Motor Rated Voltage                 | T2-05     | V                 | -  | x                                | x | x | -  |
| PM Motor Rated Current                 | T2-06     | A                 | -  | x                                | x | x | -  |
| PM Motor Base<br>Frequency             | T2-07     | Hz                | -  | x                                | - | - | -  |
| Number of PM Motor<br>Poles            | T2-08     | -                 | -  | x                                | x | x | -  |
| PM Motor Base Speed                    | T2-09     | min <sup>-1</sup> | -  | -                                | x | x | -  |
| PM Motor Stator<br>Resistance          | T2-10     | Ω                 | -  | -                                | - | - | -  |
| PM Motor d-Axis<br>Inductance          | T2-11     | mH                | -  | -                                | - | - | -  |
| PM Motor q-Axis<br>Inductance          | T2-12     | mH                | -  | -                                | - | - | -  |
| Back-EMF Units<br>Selection            | T2-13     | -                 | -  | -                                | - | - | -  |
| Back-EMF Voltage<br>Constant (Ke)      | T2-14     | *1                | -  | -                                | - | - | -  |
| Pull-In Current Level                  | T2-15     | %                 | -  | x                                | x | x | -  |
| Encoder Pulse Count<br>(PPR)           | T2-16     | -                 | -  | -                                | - | x | -  |
| Encoder Z-Pulse Offset<br>for PM Motor | T2-17     | Degrees           | -  | -                                | - | - | -  |

\*1 Changes when the value set in T2-13 changes.

#### ◆ Auto-Tuning in EZ Open Loop Vector Control Method

This section gives information about the Auto-Tuning mode for EZ Open Loop Vector Control. Auto-Tuning will set the E9-xx parameters.

Table 3.9 EZ Tuning Mode Selection

| Mode                    | Parameter Settings | Application Conditions and Benefits  | Applicable Control Method (A1-02 Setting) |
|-------------------------|--------------------|--|---|
| Motor Parameter Setting | T4-01 = 0          | <ul style="list-style-type: none"> <li>Applicable when driving an induction motor or a PM motor</li> <li>Suitable for derating torque applications, for example fans and pumps.</li> </ul>                     | EZOLV<br>(8)                              |
| Line-to-Line Resistance | T4-01 = 1          | <ul style="list-style-type: none"> <li>After Auto-Tuning, the wiring distance between the drive and motor changed by 50 m or more.</li> <li>When the motor output and drive capacity are different.</li> </ul> | EZOLV<br>(8)                              |

### ■ Auto-Tuning Input Data in EZ Open Loop Vector Control Method

To do Auto-Tuning, input data for the items in Table 3.10 that have an "x". Before starting Auto-Tuning, prepare the motor test report or record the information on the motor nameplate as a reference.

Table 3.10 Auto-Tuning Input Data in EZ Open Loop Vector Control Method

| Input Data                   | Parameter | Unit              | Auto-Tuning Mode (T4-01 Setting) |                             |
|------------------------------|-----------|-------------------|----------------------------------|-----------------------------|
|                              |           |                   | Motor Parameter Setting (0)      | Line-to-Line Resistance (1) |
| Motor Type Selection         | T4-02     | -                 | x                                | -                           |
| Motor Max Revolutions        | T4-03     | min <sup>-1</sup> | x                                | -                           |
| Motor Rated Revolutions      | T4-04     | min <sup>-1</sup> | x                                | -                           |
| Motor Rated Frequency        | T4-05     | Hz                | x                                | -                           |
| Motor Rated Voltage          | T4-06     | V                 | x                                | -                           |
| PM Motor Rated Current (FLA) | T4-07     | A                 | x                                | x                           |
| PM Motor Rated Power (kW)    | T4-08     | kW                | x                                | -                           |
| Number of Motor Poles        | T4-09     | -                 | x                                | -                           |

### ◆ Control Tuning

To increase drive responsiveness and prevent hunting, use Auto-Tuning to automatically adjust the control-related parameters.

These types of Auto-Tuning are available for the control system:

- Inertia Tuning
- ASR Tuning
- Deceleration Rate Tuning
- KEB Tuning

**Note:**

If you do Control Tuning, you cannot set  $H1-xx = 16$  [Motor 2 Selection]. Do not do Control Tuning for applications that switch between motor 1 and motor 2.

Table 3.11 Control Loop Tuning Selection

| Mode           | T3-00 | Application Conditions and Benefits  | Applicable Control Method (A1-02 Value) |            |         |         |          |            |             |            |           |
|----------------|-------|--|---|------------|---------|---------|----------|------------|-------------|------------|-----------|
|                |       |  | V/f (0)                                 | CL-V/f (1) | OLV (2) | CLV (3) | AOLV (4) | OLV/PM (5) | AOLV/PM (6) | CLV/PM (7) | EZOLV (8) |
| Inertia Tuning | 0     | <ul style="list-style-type: none"> <li>For Feed Forward Control</li> <li>When <math>L2-29 = 1</math> [Kinetic Energy Backup Method = Single Drive KEB Ride-Thru 2].</li> <li>When <math>MFD1 H1-xx = 7A</math> [KEB Ride-Thru 2 Activate (N.C.)].</li> </ul> | -                                       | -          | -       | x       | -        | -          | -           | x          | -         |
| ASR Tuning     | 1     | To let the set response frequency (including Inertia Tuning) automatically adjust the ASR gain.  | -                                       | -          | -       | x       | -        | -          | -           | x          | -         |

### 3.5 Auto-Tuning

| Mode                     | T3-00 | Application Conditions and Benefits  | Applicable Control Method (A1-02 Value) |            |         |         |          |            |             |            |           |
|--------------------------|-------|--|---|------------|---------|---------|----------|------------|-------------|------------|-----------|
|                          |       |  | V/f (0)                                 | CL-V/f (1) | OLV (2) | CLV (3) | AOLV (4) | OLV/PM (5) | AOLV/PM (6) | CLV/PM (7) | EZOLV (8) |
| Deceleration Rate Tuning | 2     | To automatically adjust the deceleration rate to prevent an <i>ov</i> [Overvoltage] fault.   | x                                       | x          | x       | x       | x        | x          | x           | x          | x         |
| KEB Tuning               | 3     | <ul style="list-style-type: none"> <li>To automatically adjust parameter settings to prevent an <i>ov</i> [Overvoltage] fault with the KEB Ride-Thru function.</li> <li>When <i>L3-11 = 1</i> [Overvoltage Suppression Select = Enabled].</li> </ul> | x                                       | x          | x       | x       | x        | x          | x           | x          | x         |

**Table 3.12 Input Data for Control Tuning**

| Input Data                | Parameters | Unit              | Auto-Tuning Mode (T3-00 Value) |                           |                     |                |
|---------------------------|------------|-------------------|--------------------------------|---------------------------|---------------------|----------------|
|                           |            |                   | Inertia Tuning (0)             | ASR (Speed Regulator) (1) | Dec Rate Tuning (2) | KEB Tuning (3) |
| Test Signal Frequency     | T3-01      | Hz                | x                              | x                         | -                   | -              |
| Test Signal Amplitude     | T3-02      | Rad               | x                              | x                         | -                   | -              |
| Motor Inertia             | T3-03      | Kg·m <sup>2</sup> | x                              | x                         | -                   | -              |
| System Response Frequency | T3-04      | Hz                | -                              | x                         | -                   | -              |

#### ■ Inertia Tuning

Inertia Tuning uses the motor speed and torque reference to estimate the system inertia and automatically sets the drive parameters related to the inertia ratio of the machinery and motor. Use Inertia Tuning for Feed Forward control or when *H1-xx = 7A* [MFDI Function Select = KEB Ride-Thru 2 Activate (N.C.)].

Inertia tuning identifies the load inertia and optimizes the speed loop gain and feed forward gain to get a high level of control capability. You can set the speed response without thinking about the load, which increases the precision when synchronizing multiple drives. Since the motor can continue to operate during a power outage, Inertia Tuning keeps the best ramp to stop deceleration curve for KEB Ride-Thru.

#### ■ ASR Tuning

ASR Tuning estimates the motor load inertia and automatically sets the parameters. ASR Tuning also uses the measured load inertia value to do an automatic adjustment after calculating the proportional gain of speed control (ASR).

#### ■ Deceleration Rate Tuning

Deceleration Rate Tuning automatically sets the deceleration rate to prevent an *ov* [Overvoltage] fault during motor deceleration. Set *C1-11* [Accel/Decel Time Switchover Freq] first to automatically set parameters *C1-02* [Deceleration Time 1] (high speed range) and *C1-08* [Deceleration Time 4] (low speed range).

#### ■ KEB Tuning

KEB Tuning automatically sets parameters used for the KEB Ride-Thru function and for the overvoltage suppression function.

Control Tuning automatically sets the parameters in Table 3.13 to the best values.

**Table 3.13 Parameters set in Control Tuning**

| Parameters Automatically Set    | Inertia Tuning | ASR Tuning | Deceleration Rate Tuning | KEB Tuning |
|---------------------------------|----------------|------------|--------------------------|------------|
| C1-02 [Deceleration Time 1]     | -              | -          | x                        | -          |
| C1-08 [Deceleration Time 4]     | -              | -          | x *1                     | -          |
| C1-09 [Fast Stop Time]          | -              | -          | -                        | x *2       |
| C5-01 [ASR Proportional Gain 1] | -              | x          | -                        | -          |
| C5-17 [Motor Inertia]           | x              | x          | -                        | -          |

| Parameters Automatically Set             | Inertia Tuning | ASR Tuning | Deceleration Rate Tuning | KEB Tuning |
|--|----------------|------------|--------------------------|------------|
| C5-37 [Motor 2 Inertia]                  | x              | x          | -                        | -          |
| C5-18 [Load Inertia Ratio]               | x              | x          | -                        | -          |
| C5-38 [Motor 2 Load Inertia Ratio]       | x              | x          | -                        | -          |
| L2-06 [Kinetic Energy Backup Decel Time] | -              | -          | -                        | x *3       |
| L3-24 [Motor Accel Time @ Rated Torque]  | x              | x          | -                        | -          |
| L3-25 [Load Inertia Ratio]               | x              | x          | -                        | x          |
| n5-02 [Motor Inertia Acceleration Time]  | x              | x          | -                        | -          |
| n5-03 [Feed Forward Control Gain]        | x              | x          | -                        | -          |

\*1 The drive automatically sets C1-08 [Deceleration Time 4] only when C1-11 [Accel/Decel Time Switchover Freq]  $\neq 0$ .

\*2 When L2-29 = 0 [Kinetic Energy Backup Method = Single Drive KEB Ride-Thru 1], the drive will automatically adjust C1-09 [Fast Stop Time] and will not adjust L2-06 [Kinetic Energy Backup Decel Time]. If the Fast Stop time must not change, do not do KEB Tuning.

\*3 When L2-29 = 1, 2, or 3 [Kinetic Energy Backup Method = Single Drive KEB Ride-Thru 2, System KEB Ride-Thru 1, or System KEB Ride-Thru 2], the drive will automatically adjust L2-06 [Kinetic Energy Backup Decel Time].

## ◆ Precautions before Auto-Tuning


Examine the topics in this section before you start Auto-Tuning.

### ■ Prepare for Basic Auto-Tuning

- You must input data from the motor nameplate or motor test report to do Auto-Tuning. Make sure that this data is available before Auto-Tuning the drive.
- For best performance, make sure that the drive input supply voltage is equal to or more than the motor rated voltage.

#### Note:

Better performance is possible when you use a motor with a rated voltage that is less than the input supply voltage (by 20 V for 200 V class models or by 40 V for 400 V class models). This is very important when operating the motor at more than 90% of base speed, where high torque precision is necessary. If the input power supply is equal to the motor rated voltage, the drive output voltage will not be sufficient, and performance will decrease.

- Push  on the keypad to cancel Auto-Tuning.
- If a Safe Disable input signal is input to the drive during Auto-Tuning, Auto-Tuning measurements will not complete successfully. If this occurs, cancel the Auto-Tuning, then do it again.
- Table 3.14 shows the status of input/output terminals during Auto-Tuning.

**Table 3.14 Status of Input/Output Terminals during Auto-Tuning**

| Auto-Tuning Type            | Mode  |                                | Multifunctional input                         | Multifunctional output *1                     |
|-----------------------------|---|--------------------------------|---|---|
| Induction Motor Auto-Tuning | Rotational                                      | Rotational Auto-Tuning         | Disabled                                      | Functions the same as during usual operation. |
|                             | Stationary                                      | Stationary Auto-Tuning 1       | Disabled                                      | Keeps the status at the start of Auto-Tuning. |
|                             |   | Line-to-Line Resistance        | Disabled                                      | Keeps the status at the start of Auto-Tuning. |
| PM Motor Auto-Tuning        | Rotational                                      | Z-Pulse Offset (Pole Position) | Disabled                                      | Keeps the status at the start of Auto-Tuning. |
|                             |   | PM Rotational Auto-Tuning      | Disabled                                      | Functions the same as during usual operation. |
|                             | Stationary                                      | PM Motor Parameter Settings    | Disabled                                      | Disabled                                      |
|                             |   | PM Stationary Auto-Tuning      | Disabled                                      | Keeps the status at the start of Auto-Tuning. |
|                             | PM Stationary Auto-Tuning for Stator Resistance | Disabled                       | Keeps the status at the start of Auto-Tuning. |   |

### 3.5 Auto-Tuning

| Auto-Tuning Type       | Mode       |                          | Multifunctional input | Multifunctional output <sup>*1</sup>          |
|------------------------|------------|--------------------------|-----------------------|---|
| EZ Tuning              | Stationary | Motor Parameter Setting  | Disabled              | Disabled                                      |
|                        |            | Line-to-Line Resistance  | Disabled              | Keeps the status at the start of Auto-Tuning. |
| ASR and Inertia Tuning | Rotational | Inertia Tuning           | Disabled              | Functions the same as during usual operation. |
|                        |            | ASR (Speed Regulator)    | Disabled              | Functions the same as during usual operation. |
|                        |            | Deceleration Rate Tuning | Disabled              | Functions the same as during usual operation. |
|                        |            | KEB Tuning               | Disabled              | Functions the same as during usual operation. |

\*1 A terminal to which  $H2-xx = E$  [MFDO Function Select = Fault] is assigned functions the same as during usual operation.

**WARNING! Crush Hazard.** Wire a sequence that will not let a multi-function output terminal open the holding brake during Stationary Auto-Tuning. If the holding brake is open during Stationary Auto-Tuning, it can cause serious injury or death.

**WARNING! Before you do Rotational Auto-Tuning, disconnect the load from the motor. The load can move suddenly and cause serious injury or death.**

**WARNING! Crush Hazard.** This seems incorrect. The drive should not take a 60 Hz motor to 90 Hz during tuning. We think this is a translation error. Please confirm it. Increased motor frequency can cause serious injury or death.

**WARNING! Electrical Shock Hazard.** During Auto-Tuning, the motor will receive high voltage when the motor is stopped. Do not touch the motor until Auto-Tuning is complete. If you touch a motor that is energized, it can cause serious injury or death.

#### ■ Precautions before Rotational Auto-Tuning

**WARNING! Electrical Shock Hazard.** During Auto-Tuning, the motor will receive high voltage when the motor is stopped. Do not touch the motor until Auto-Tuning is complete. If you touch a motor that is energized, it can cause serious injury or death.

- Uncouple the drive from the motor before Rotational Auto-Tuning to prevent drive malfunction. If you do Rotational Auto-Tuning with the motor connected to a load that is more than 30% of the motor duty rating, the drive will not correctly calculate the motor parameters and the motor can operate incorrectly.
- When the load is 30% or less of the motor duty rating, you can do Auto-Tuning with the motor connected to a load.
- Make sure that the motor magnetic brake is released.
- Make sure that external force from the machine will not cause the motor to rotate.

#### ■ Precautions before Stationary Auto-Tuning

- Make sure that the motor magnetic brake is not open.
- Make sure that external force from the machine will not cause the motor to rotate.

**WARNING! Electrical Shock Hazard.** During Auto-Tuning, the motor will receive high voltage when the motor is stopped. Do not touch the motor until Auto-Tuning is complete. If you touch a motor that is energized, it can cause serious injury or death.

#### Automatically Set E2-02 [Motor Rated Slip] and E2-03 [Motor No-Load Current]

If  $T1-12 = 1$  [Test Mode Selection = Yes] when selecting Stationary Auto-Tuning, the drive will automatically set motor parameters E2-02 [Motor Rated Slip] and E2-03 [Motor No-Load Current] after Auto-Tuning is complete when you use the motor for the first time in Drive Mode.

After Stationary Auto-Tuning is complete, use this procedures to do the operation in test mode:

1. Check the E2-02 and E2-03 values on the “Modified Parameters/Fault Log” screen or the “Parameters” screen.
2. Operate the motor in Drive Mode with these conditions:
  - Make sure that you connect all wiring between the drive and motor
  - Make sure that a mechanical brake on the motor shaft is not locked
  - The maximum motor load must be 30% of the rated load.
  - Keep a constant speed of 30% of E1-06 [Base Frequency] (default value = maximum frequency) or more for 1 second or longer.
3. After the motor stops, check the E2-02 and E2-03 values on the “Modified Parameters/Fault Log” screen or the “Parameters” screen again.
4. Make sure that the input data is correct.  
When the settings in E2-02 and E2-03 are different than in step 1, the drive set the values automatically.



**Note:**

- If you cannot operate the motor with the conditions in step 2 for the first test run and if the values set in *E2-02* and *E2-03* are much different than data in the official test report for the motor and the data listed in *Defaults by Drive Model and Duty Rating ND/HD on page 133*, these problems can occur:
  - Motor vibrations or hunting
  - Not sufficient torque
  - Overcurrent
- In elevator applications, there is a risk of the cage falling and causing personal injury. Do one of these precautions to decrease the risk:
  - After doing Stationary Auto-Tuning, operate the drive as specified by the conditions and procedure above.
  - Set  $T1-12 = 0$  [*Test Mode Selection = No*].
  - Do Rotational Auto-Tuning.
- If you initialize the drive after completing Step 1, do the procedure beginning from Step 1 again.
- For general-purpose motors, the target value for *E2-02* is 1 Hz to 3 Hz, and the target rated current for *E2-03* is 30% to 65%. Larger capacity motors have a lower rated slip, and a smaller ratio for the no-load current rated current. Refer to *Defaults by Drive Model and Duty Rating ND/HD on page 133*.

### ■ Precautions before Stationary Auto-Tuning for Line-to-Line Resistance and Stator Resistance Auto-Tuning

In V/f control, when the motor cable is 50 meters (164 feet) or longer, do Stationary Auto-Tuning for Line-to-Line Resistance.

**WARNING!** *Electrical Shock Hazard. During Auto-Tuning, the motor will receive high voltage when the motor is stopped. Do not touch the motor until Auto-Tuning is complete. If you touch a motor that is energized, it can cause serious injury or death.*

### ■ Precautions before Inertia Tuning and ASR Tuning

Before Inertia Tuning or ASR Tuning, check these items:

**WARNING!** *Electrical Shock Hazard. During Auto-Tuning, the motor will receive high voltage when the motor is stopped. Do not touch the motor until Auto-Tuning is complete. If you touch a motor that is energized, it can cause serious injury or death.*

- Do rotational motor parameter tuning or look at the motor test report or nameplate to enter the values manually.
- Make sure that the motor magnetic brake is released.
- Connect the motor and load.
- Make sure that external force from the machine will not cause the motor to rotate.
- Make sure that the machine does not prevent reverse rotation. You cannot do Inertia Tuning or ASR Tuning with machines that prevent reverse rotation.
- When the motor can rotate during Auto-Tuning, check for safety issues near the drive, motor, and machine.

**Note:**

If there are gears between the machine and motor shaft, Inertia Tuning or ASR Tuning are possibly not applicable.

### ■ Precautions before Using Deceleration Rate Tuning and KEB Tuning

Before Deceleration Rate Tuning or KEB Tuning, check these items:

**Note:**

- Do not do Deceleration Rate Tuning if you use a braking resistor unit or a regenerative converter.
- Do Deceleration Rate Tuning and KEB Tuning with the load attached to the motor.
- Do not do Deceleration Rate Tuning or KEB Tuning for these applications:
  - In Deceleration Rate Tuning and KEB Tuning, the drive will automatically rotate the motor forward and accelerate and decelerate the motor again and again.
    - On a machine that does not let the motor rotate forward
    - In applications with a small range of operation (trolleys and other such applications that can only move linearly)
    - Applications where sudden acceleration and sudden deceleration are not applicable.
- To do KEB Tuning with the external main circuit capacitors connected to the drive, set *L3-26* [*Additional DC Bus Capacitors*] then do KEB Tuning.
- Do not do KEB Tuning or Deceleration Rate Tuning if the drive is set to use  $H1-xx = 16$  [*MFDI Function Select = Motor 2 Selection*]. Failure to obey can cause an *ov* [*Overvoltage*] fault.

## 3.6 Test Run

After you use the Setup Wizard to set the basic parameters and Auto-Tune the drive, the next step is to do a test run.

**WARNING! Crush Hazard.** Test the system to make sure that the drive operates safely after you wire the drive and set parameters. If you do not test the system, it can cause damage to equipment or serious injury or death.

### ◆ No-Load Test Run

Before connecting the motor to the machine, make sure that you check the operation status of the motor.

#### ■ Precautions before Operation

Before rotating the motor, check these items:

- Check for safety issues near the drive, motor, and machine.
- Make sure that all emergency stop circuits and machine safety mechanisms are operating correctly.


#### ■ Items to Check before Operation

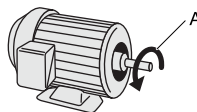
Check these items before operation:

- Is the motor rotating in the forward direction?
- Is the motor rotating smoothly (no unusual sounds or unusual vibrations)?
- Does the motor accelerate/decelerate smoothly?


### ◆ Do a No-Load Test Run

Do these steps for a no-load test run:

1. Energize the drive, or push **F2** to show the HOME screen.  
If [Home] is not shown on **F2**, push **F1** (Back) to show [Home] on **F2**.
2. Push **LORE** to illuminate the LOCAL/REMOTE indicator.
3. Push  to show *d1-01 [Reference 1]*, and set it to 6.00 Hz.
4. Push **RUN**.  
The RUN indicator illuminates, and the motor runs at 6.00 Hz in the forward direction.
5. Make sure that the motor is rotating in the correct direction and that the drive does not show a fault.  
If the drive detects a fault, remove the cause.



**A - Forward Rotation of Motor (Counter Clockwise Direction as Seen from Load Shaft)**


6. Push  to increase the frequency reference value.  
Change the setting value in increments of 10 Hz if necessary and examine the response.
7. Each time you increase the setting value, use *U1-03 [Output Current]* to check the drive output current.  
When the output current of the drive is not more than the motor rated current, the status is correct.  
Ex.: 6 Hz → 20 Hz → 30 Hz → 40 Hz → 50 Hz → 60 Hz
8. Make sure that the motor rotates correctly, then push **STOP**.  
The RUN indicator will flash. When the motor stops, the indicator will go out.

### ◆ Actual-Load Test Run

Test the operation without a load, then connect the motor and machine to do a test run.

## ■ Precautions before Operation

Before rotating the motor, check these items:









- Check for safety issues near the drive, motor, and machine.
- Make sure that all emergency stop circuits and machine safety mechanisms are operating correctly.
- Make sure that the motor is fully stopped.
- Connect the motor with the machine.  
Make sure that there are no loose installation screws and that the motor load shafts and machine junctions are correctly secured.
- Keep the keypad near you to push  immediately if there is unusual or incorrect operation.

## ■ Items to Check before Operation

- Make sure that the direction of the machine operation is correct (The motor must rotate in the correct direction).
- Make sure that the motor accelerates and decelerates smoothly.

## ◆ Do an Actual-Load Test Run

Connect the motor and machine, then do the test run with the same procedure you used for the no-load test run.

- Make sure that *U1-03 [Output Current]* is not too high.
  1. Energize the drive, or push  (Home) to show the HOME screen.  
If [Home] is not shown on , push  (Back) to show [Home] on .
  2. Set *d1-01 [Reference 1]* to 6.00 Hz.
  3. Push  to illuminate the LOCAL/REMOTE indicator.
  4. Push .  
The RUN indicator illuminates, and the motor runs at 6.00 Hz in the forward direction.
  5. Make sure that the motor is rotating in the correct direction and that the drive does not show a fault.  
If the drive detects a fault, remove the cause.
  6. Push  to increase the frequency reference value.  
Change the setting value in increments of 10 Hz if necessary and examine the response.
  7. Each time you increase the setting value, use *U1-03 [Output Current]* to check the drive output current.  
When the output current of the drive is not more than the motor rated current, the status is correct.  
Ex.: 6 Hz → 20 Hz → 30 Hz → 40 Hz → 50 Hz → 60 Hz
  8. Make sure that the motor rotates correctly, then push .  
The RUN indicator will flash. When the motor stops, the indicator will go out.
  9. Change the frequency reference and direction of motor rotation, and make sure that there are no unusual sounds or vibrations.
  10. If there are hunting or oscillation errors caused by control function, adjust the settings to stop the errors.

## 3.7 Fine Tuning during Test Runs (Adjust the Control Function)

This section gives information about the adjustment procedures to stop hunting or oscillation errors caused by control function during a test run. Adjust the applicable parameters as specified by your control method and drive status.

- *V/f Control and Closed Loop V/f Control on page 608*
- *Open Loop Vector Control Method on page 609*
- *Closed Loop Vector Control Method on page 610*
- *Advanced Open Loop Vector Control Method on page 611*
- *Fine-Tuning Open Loop Vector Control for PM Motors on page 612*
- *Advanced Open Loop Vector Control Method for PM on page 613*
- *Closed Loop Vector Control Method for PM on page 613*
- *EZ Open Loop Vector Control Method on page 614*

**Note:**

This section only lists frequently adjusted parameters. If you must adjust parameters that have a higher degree of precision, contact Yaskawa.

### ◆ V/f Control and Closed Loop V/f Control

**Table 3.15 Parameters for Fine Tuning the Drive (V/f and CL-V/f)**

| Issue   | Parameter Number  | Possible Solutions  | Default   | Recommended Setting  |
|---|---|---|---|--|
| Hunting or oscillation at mid-range speeds (10 Hz to 40 Hz)   | n1-02 [Hunting Prevention Gain Setting]   | <ul style="list-style-type: none"> <li>• If torque is not sufficient with heavy loads, decrease the setting value.</li> <li>• If hunting or oscillation occur with light loads, increase the setting value.</li> <li>• If hunting occurs with a low-inductance motor, for example a motor with a larger frame size or a high-frequency motor, lower the setting value.</li> </ul> | 1.00  | 0.10 - 2.00  |
| <ul style="list-style-type: none"> <li>• The volume of the motor excitation sound is too high.</li> <li>• Hunting or oscillation at low speeds (10 Hz or lower), or at mid-range speeds (10 Hz to 40 Hz)</li> </ul> | C6-02 [Carrier Frequency Selection]   | <ul style="list-style-type: none"> <li>• If the volume of the motor excitation sound is too high, increase the carrier frequency.</li> <li>• If hunting or oscillation occur at low or mid-range speeds, decrease the carrier frequency.</li> </ul>   | 1 (2 kHz) *1  | 1 to upper limit value   |
| <ul style="list-style-type: none"> <li>• Unsatisfactory motor torque and speed response</li> <li>• Hunting or oscillation</li> </ul>  | C4-02 [Torque Compensation Delay Time]  | <ul style="list-style-type: none"> <li>• If torque or speed response are slow, decrease the setting value.</li> <li>• If hunting or oscillation occur, increase the setting value.</li> </ul>   | 200 ms *2   | 100 ms to 1000 ms  |
| <ul style="list-style-type: none"> <li>• Torque at low speeds (10 Hz or lower) is not sufficient.</li> <li>• Hunting or oscillation</li> </ul>  | C4-01 [Torque Compensation Gain]  | <ul style="list-style-type: none"> <li>• If torque at low speeds (10 Hz or lower) is not sufficient, increase the setting value.</li> <li>• If hunting or oscillation occur with light loads, decrease the setting value.</li> </ul>  | 1.00  | 0.50 - 1.50  |
| <ul style="list-style-type: none"> <li>• Torque at low speeds (10 Hz or lower) is not sufficient.</li> <li>• Large initial vibration at start up.</li> </ul>  | <ul style="list-style-type: none"> <li>• E1-08 [Mid Point A Voltage]</li> <li>• E1-10 [Minimum Output Voltage]</li> </ul>         | <ul style="list-style-type: none"> <li>• If torque at low speeds (10 Hz or lower) is not sufficient, increase the setting value.</li> <li>• If there is large initial vibration at start up, decrease the setting value</li> </ul>  | <ul style="list-style-type: none"> <li>• E1-08: 15.0 V *3</li> <li>• E1-10: 9.0 V *3</li> </ul> | Default setting +/- 5 V *4   |
| Speed precision is unsatisfactory. (V/f Control)  | C3-01 [Slip Compensation Gain]  | Set E2-01 [Motor Rated Current], E2-02 [Motor Rated Slip], and E2-03 [Motor No-Load Current], then adjust C3-01.  | 0.0 (no slip compensation)  | 0.5 - 1.5  |
| Speed precision is unsatisfactory. (Closed Loop V/f Control)  | <ul style="list-style-type: none"> <li>• C5-01 [ASR Proportional Gain 1]</li> <li>• C5-02 [ASR Integral Time 1 (I)] *5</li> </ul> | Adjust C5-01, C5-02.  | <ul style="list-style-type: none"> <li>• C5-01: 0.20</li> <li>• C5-02: 0.200 s</li> </ul>       | <ul style="list-style-type: none"> <li>• Proportional gain = 0.10 to 1.00</li> <li>• Integral time = 0.100 to 2.000 s</li> </ul> |

\*1 The default setting changes when the settings for C6-01 [Normal / Heavy Duty Selection] and o2-04 [Drive Model (KVA) Selection] change.

\*2 The default setting changes when the settings for A1-02 [Control Method Selection] and o2-04 [Drive Model (KVA) Selection] change.

\*3 The default setting changes when the settings for A1-02 [Control Method Selection] and E1-03 [V/f Pattern Selection] change.

### 3.7 Fine Tuning during Test Runs (Adjust the Control Function)

- \*4 Recommended settings are for 200 V class drives. Multiply the voltage by 2 for 400 V class drives.
- \*5 In Closed Loop V/f Control, ASR only controls the output frequency. You cannot make a high-gain as in Closed Loop Vector control.

#### ◆ Open Loop Vector Control Method

In Open Loop Vector Control, keep *C4-01 [Torque Compensation Gain]* at its default setting (1.00).

If you cannot get speed precision during regeneration in Open Loop Vector Control, set *C3-04 = 1 [Slip Compensation @ Regen Select = Enabled above 6 Hz]*.

**Table 3.16 Parameters for Fine Tuning the Drive (A1-02 = 2[OLV])**

| Issue   | Parameter Number                          | Possible Solutions  | Default | Recommended Setting |
|---|---|---|---------|---------------------|
| <ul style="list-style-type: none"> <li>• Unsatisfactory motor torque and speed response</li> <li>• Hunting or oscillation at mid-range speeds (10 Hz to 40 Hz)</li> </ul> | n2-01 [SpdFeedbackDetectCtr (AFR) Gain]   | <ul style="list-style-type: none"> <li>• To increase the speed of torque or speed response, decrease the setting value in increments of 0.05.</li> <li>• If hunting or oscillation occur, decrease the setting value in increments of 0.05.</li> </ul>  | 1.00    | 0.50 - 2.00         |
|   | n2-02 [SpdFeedbackDetCtr(AFR) TimeConst1] | <ul style="list-style-type: none"> <li>• To increase the speed of torque or speed response, decrease the setting value in increments of 10 ms and examine the response.</li> <li>• If hunting or oscillation occur or if the load inertia is too much, increase the setting value in increments of 50 ms and examine the response.</li> </ul> <p><b>Note:</b><br/>Make sure that this parameter setting is: <math>n2-02 \leq n2-03</math> [Automatic Freq Regulator Time 2] holds true.<br/>When you adjust <i>n2-02</i>, you must also increase the <i>C4-02 [Motor 1 Torque Comp Delay Time]</i> value by the same ratio.</p> | 50 ms   | 50 ms to 2000 ms    |
| <i>ov [overvoltage]</i> occurs when the drive stops accelerating, starts to decelerate, or when there are large changes in the load.                                      | n2-03 [SpdFeedbackDetCtr(AFR) TimeConst2] | <ul style="list-style-type: none"> <li>• If <i>ov</i> occurs, increase the setting value in increments of 50 ms and examine the response.</li> <li>• If the response is not sufficient, decrease the setting value in increments of 10 ms and examine the response.</li> </ul> <p><b>Note:</b><br/>Make sure that this parameter setting is: <math>n2-02</math> [Automatic Freq Regulator Time 1] <math>\leq n2-03</math>. When you adjust <i>n2-03</i> you must also increase the <i>C4-06 [Motor 2 Torque Comp Delay Time]</i> value by the same ratio.</p>   | 750 ms  | 750 ms to 2000 ms   |
|   | C4-06 [Motor 2 Torque Comp Delay Time]    | <ul style="list-style-type: none"> <li>• If <i>ov</i> occurs, increase the setting value in increments of 10 ms and examine the response.</li> <li>• If the response is not sufficient, decrease the setting value in increments of 2 ms and examine the response.</li> </ul> <p><b>Note:</b><br/>Make sure that this parameter setting is: <math>C4-02</math> [Torque Compensation Delay Time] <math>\leq C4-06</math>.<br/>When you adjust <i>C4-06</i>, you must also increase the <i>n2-03 [SpdFeedbackDetCtr(AFR) TimeConst2]</i> value by the same ratio.</p>   | 150 ms  | 150 ms to 750 ms    |

### 3.7 Fine Tuning during Test Runs (Adjust the Control Function)

| Issue   | Parameter Number  | Possible Solutions  | Default   | Recommended Setting        |
|---|---|---|---|----------------------------|
| <ul style="list-style-type: none"> <li>Unsatisfactory motor torque and speed response</li> <li>Hunting or oscillation</li> </ul>  | C4-02 [Torque Compensation Delay Time 1]  | <ul style="list-style-type: none"> <li>If torque or speed response are slow, decrease the setting value in increments of 2 ms.</li> <li>If hunting or oscillation occur, increase the setting value in increments of 10 ms.</li> </ul> <p><b>Note:</b><br/>Make sure that this parameter setting is: <math>C4-02 \leq C4-06</math> [Motor 2 Torque Comp Delay Time].<br/>When you adjust C4-02, you must also increase the n2-02 [SpdFeedbackDetCtr (AFR) TimeConst] value by the same ratio.</p> | 20 ms *1  | 20 ms to 100 ms *1         |
| <ul style="list-style-type: none"> <li>Speed response is slow.</li> <li>Speed is not stable.</li> </ul>   | C3-02 [Slip Compensation Delay Time]  | <ul style="list-style-type: none"> <li>If speed response is slow, decrease the setting value in increments of 10 ms.</li> <li>If speed is not stable, increase the value in increments of 10 ms.</li> </ul>   | 200 ms *1   | 100 ms to 500 ms           |
| Speed precision is unsatisfactory.  | C3-01 [Slip Compensation Gain]  | <ul style="list-style-type: none"> <li>If speed is too slow, increase the setting value in increments of 0.1.</li> <li>If speed is too fast, decrease the setting value in increments of 0.1.</li> </ul>  | 1.0 *2  | 0.5 - 1.5                  |
| <ul style="list-style-type: none"> <li>The volume of the motor excitation sound is too high.</li> <li>Hunting or oscillation at low speeds (10 Hz or lower)</li> </ul>  | C6-02 [Carrier Frequency Selection]   | <ul style="list-style-type: none"> <li>If the volume of the motor excitation sound is too high, increase the carrier frequency.</li> <li>If hunting or oscillation occur at low speeds, decrease the carrier frequency.</li> </ul>  | 1 (2 kHz) *3  | 0 to upper limit value     |
| <ul style="list-style-type: none"> <li>Torque at low speeds (10 Hz or lower) is not sufficient. speed response is slow.</li> <li>Speed response is slow.</li> <li>Large initial vibration at start up.</li> </ul> | <ul style="list-style-type: none"> <li>E1-08 [Mid Point A Voltage]</li> <li>E1-10 [Minimum Output Voltage]</li> </ul> | <ul style="list-style-type: none"> <li>If torque or speed response are slow, increase the setting value.</li> <li>If there is large initial vibration at start up, decrease the setting value</li> </ul> <p><b>Note:</b><br/>If the setting value is set too high, a large torque reference may be output even with light loads.</p>  | <ul style="list-style-type: none"> <li>E1-08: 11.0 V *2</li> <li>E1-10: 2.0 V *2</li> </ul> | Default setting +/- 2 V *4 |

\*1 The default setting changes when the settings for A1-02 [Control Method Selection] and o2-04 [Drive Model (KVA) Selection] change.

\*2 The default setting changes when the settings for A1-02 [Control Method Selection] and E1-03 [V/f Pattern Selection] change.

\*3 The default setting changes when the settings for C6-01 [Normal / Heavy Duty Selection] and o2-04 change.

\*4 Recommended settings are for 200 V class drives. Multiply the voltage by 2 for 400 V class drives.

### ◆ Closed Loop Vector Control Method

Table 3.17 Parameters for Fine Tuning the Drive (CLV)

| Issue  | Parameter Number   | Possible Solutions  | Default | Recommended Setting                |
|--|--|---|---------|------------------------------------|
| <ul style="list-style-type: none"> <li>Unsatisfactory motor torque and speed response</li> <li>Hunting or oscillation</li> </ul> | <ul style="list-style-type: none"> <li>High speed C5-01 [ASR Proportional Gain 1]</li> <li>Low speed C5-03 [ASR Proportional Gain 2 (P)] *1</li> </ul> | <ul style="list-style-type: none"> <li>If torque or speed response are slow, increase the setting value in increments of 5.00.</li> <li>If hunting or oscillation occur, decrease the setting value.</li> </ul> | 20.00   | 10.00 - 50.00                      |
|  | <ul style="list-style-type: none"> <li>High speed C5-02 [ASR Integral Time 1]</li> <li>Low speed C5-04 [ASR Integral Time 2 (I)] *1</li> </ul>         | <ul style="list-style-type: none"> <li>If torque or speed response are slow, decrease the setting value.</li> <li>If hunting or oscillation occur, increase the setting value.</li> </ul>                       | 0.500 s | 0.300 s to 1.000 s                 |
| The drive cannot find ASR proportional gain or integral time for low speed or high speed.  | C5-07 [ASR Gain Switchover Frequency] *1   | Change the ASR proportional gain and ASR integral time to conform to the output frequency.  | 0.0 Hz  | 0.0 Hz to maximum output frequency |

### 3.7 Fine Tuning during Test Runs (Adjust the Control Function)

| Issue   | Parameter Number                    | Possible Solutions  | Default        | Recommended Setting          |
|---|-------------------------------------|---|----------------|------------------------------|
| Hunting or oscillation  | C5-06 [ASR Delay Time] *1           | <ul style="list-style-type: none"> <li>If torque or speed response are slow, decrease the setting value in increments of 0.010.</li> <li>If the rigidity of the machine is unsatisfactory and vibration is possible, increase the setting value.</li> </ul> | 0.004 s        | 0.004 s to 0.020 s           |
| <ul style="list-style-type: none"> <li>The volume of the motor excitation sound is too high.</li> <li>Hunting or oscillation at low speeds (3 Hz or lower)</li> </ul> | C6-02 [Carrier Frequency Selection] | <ul style="list-style-type: none"> <li>If the volume of the motor excitation sound is too high, increase the carrier frequency.</li> <li>If hunting or oscillation occur at low speeds, decrease the carrier frequency.</li> </ul>                          | 1 (2.0 kHz) *2 | 2.0 kHz to upper limit value |

\*1 Refer to the section on *C5-xx parameters* for more information about speed control (ASR).

\*2 The default setting changes when the settings for *C6-01 [Normal / Heavy Duty Selection]* and *o2-04 [Drive Model (KVA) Selection]* change.

### ◆ Advanced Open Loop Vector Control Method

Table 3.18 Parameters for Fine Tuning the Drive (AOLV)

| Issue  | Parameter Number   | Possible Solutions  | Default  | Recommended Setting                                    |
|--|--|---|--|--|
| <ul style="list-style-type: none"> <li><i>oS [Overspeed]</i> occurs.</li> <li>Hunting or oscillation.</li> </ul>                 | T1-01 [Auto-Tuning Mode Selection]   | <ul style="list-style-type: none"> <li>Make sure that the output of the drive and the motor are connected correctly.</li> <li>Do Rotational Auto-Tuning for a single motor.</li> </ul>  | -  | 0  |
| The volume of the motor excitation sound is too high.  | C6-02 [Carrier Frequency Selection]  | If the volume of the motor excitation sound is too high, increase the carrier frequency.  | 1 (2 kHz) *1   | 1 to upper limit value                                 |
| Speed precision is unsatisfactory  | E2-02 [Motor Rated Slip]   | <ul style="list-style-type: none"> <li>Decouple the motor and machine and do Rotational Auto-Tuning.</li> <li>If the motor speed is slow, increase the value of <i>E2-02</i> in small increments (approximately 0.1% of the default setting value).</li> <li>If the motor speed is fast, decrease the value of <i>E2-02</i> in small increments (approximately 0.1% of the default setting value).</li> </ul> | *2   | Set to a value that is $\pm 5\%$ of the current value. |
| <ul style="list-style-type: none"> <li>Unsatisfactory motor torque and speed response</li> <li>Hunting or oscillation</li> </ul> | <ul style="list-style-type: none"> <li>High speed<br/>C5-01 [ASR Proportional Gain 1]</li> <li>Low speed<br/>C5-03 [ASR Proportional Gain 2 (P)] *3</li> </ul>   | <ul style="list-style-type: none"> <li>If torque or speed response are slow, increase the setting value in increments of 5.00.</li> <li>If hunting or oscillation occur, decrease the setting value.</li> </ul>   | <ul style="list-style-type: none"> <li>C5-01 = 10.00</li> <li>C5-03 = 20.00</li> </ul>   | 10.00 - 50.00  |
|  | <ul style="list-style-type: none"> <li>High speed<br/>C5-02 [ASR Integral Time 1]</li> <li>Low speed<br/>C5-04 [ASR Proportional Gain 2 (P)] *3</li> </ul>   | <ul style="list-style-type: none"> <li>If torque or speed response are slow, decrease the setting value.</li> <li>If hunting or oscillation occur, increase the setting value.</li> </ul>   | 0.500 s  | 0.300 s to 1.000 s                                     |
| The drive cannot find speed response for low speed or high speed.  | <ul style="list-style-type: none"> <li>C5-07 [ASR Gain Switchover Frequency] *4</li> <li>High speed<br/>C5-01 [ASR Proportional Gain 1]</li> <li>C5-02 [ASR Integral Time 1]</li> <li>Low speed<br/>C5-03 [ASR Proportional Gain 2 (P)] *3</li> <li>C5-04 [ASR Integral Time 2]</li> </ul> | Change the ASR proportional gain and ASR integral time to conform to the output frequency.  | <ul style="list-style-type: none"> <li>C5-07 = 0.0 Hz</li> <li>C5-01 = 10.00</li> <li>C5-02 = 0.500 s</li> <li>C5-03 = 20.00</li> <li>C5-04 = 0.500 s</li> </ul> | C5-07: 0.0 to maximum output frequency                 |
| Hunting or oscillation   | C5-06 [ASR Delay Time] *4  | <ul style="list-style-type: none"> <li>If torque or speed response are slow, decrease the setting value in increments of 0.010.</li> <li>If the rigidity of the machine is unsatisfactory and vibration is possible, increase the setting value.</li> </ul>   | 0.004 s  | 0.004 s to 0.020 s                                     |

\*1 The default setting changes when the settings for *C6-01 [Normal / Heavy Duty Selection]* and *o2-04 [Drive Model (KVA) Selection]* change.

\*2 The default setting changes when the setting for *o2-04 [Drive Model Selection]* changes.

### 3.7 Fine Tuning during Test Runs (Adjust the Control Function)

- \*3 Refer to the section on *C5-xx parameters* for more information about speed control (ASR).
- \*4 The best values for a no-load operation are different than the best values for actual loading operation.

#### ◆ Fine-Tuning Open Loop Vector Control for PM Motors

**Table 3.19 Parameters for Fine Tuning the Drive (A1-02 = 5[OLV/PM])**

| Issue   | Parameter Number  | Possible Solutions   | Default  | Recommended Setting  |
|---|---|--|--|--|
| Unsatisfactory motor performance  | E1-xx parameters, E5-xx parameters  | <ul style="list-style-type: none"> <li>• Check the settings for E1-06, E1-04 [Base Frequency, Maximum Output Frequency].</li> <li>• Check the E5-xx and make sure that all motor data has been set correctly.</li> </ul> <p><b>Note:</b><br/>Do not set E5-05 [PM Motor Resistance (ohms/phase)] to a line-to-line resistance value.</p> <ul style="list-style-type: none"> <li>• Do Auto-Tuning.</li> </ul> | -  | -  |
| Unsatisfactory motor torque and speed response  | n8-55 [Motor to Load Inertia Ratio]   | Adjust to match the load inertia ratio of the motor and machine.   | 0  | Near the actual load inertia ratio.  |
|   | n8-45 [Speed Feedback Detection Gain]   | Decrease the setting value in increments of 0.05.  | 0.80   | -  |
|   | C4-01 [Torque Compensation Gain]  | Adjust the setting value.<br><b>Note:</b><br>Setting this value too high can cause overcompensation and motor oscillation.   | 0.00   | 1.00   |
| <ul style="list-style-type: none"> <li>• Oscillation when the motor starts.</li> <li>• Motor stalls.</li> </ul> | n8-51 [Pull-in Current @ Accel/Decel]   | Increase the setting value in increments of 5%.  | 50%  | -  |
|   | <ul style="list-style-type: none"> <li>• b2-02 [DC Injection Braking Current]</li> <li>• b2-03 [DC Inject Braking Time at Start]</li> </ul> | Use DC Injection Braking at start.<br><b>Note:</b><br>This can cause the motor to rotate in reverse for approximately 1/8 of a turn at start.  | <ul style="list-style-type: none"> <li>• b2-02: 50%</li> <li>• b2-03: 0.00 s</li> </ul>  | <ul style="list-style-type: none"> <li>• b2-02: Adjust as necessary.</li> <li>• b2-03: 0.5 s</li> </ul>  |
|   | n8-55 [Motor to Load Inertia Ratio]   | Increase the setting value.<br><b>Note:</b><br>When operating a single motor or with a minimum amount of inertia, setting this value too high can cause motor oscillation.   | 0  | Near the actual load inertia ratio.  |
| There is too much current during deceleration.  | n8-79 [Pull-in Current at Deceleration]   | Set $n8-79 < n8-51$ .  | 50%<br><b>Note:</b><br>When $n8-79 = 0$ , the drive will apply the $n8-51$ setting to the pull-in current during deceleration. | Decrease in increments of 5%.  |
| Stalling or oscillation occurs when load is applied during constant speed                                       | n8-47 [Pull-in Current Comp Filter Time]  | Decrease the setting value in increments of 0.2 s.   | 5.0 s  | -  |
|   | n8-48 [Pull-in/Light Load Id Current]   | Increase the setting value in increments of 5%.  | 30%  | -  |
|   | n8-55 [Motor to Load Inertia Ratio]   | Increase the setting value.<br><b>Note:</b><br>When operating a single motor or with a minimum amount of inertia, setting this value too high can cause motor oscillation.   | 0  | Near the actual load inertia ratio.  |
| Hunting or oscillation  | n8-45 [Speed Feedback Detection Gain]   | Increase the setting value in increments of 0.05.  | 0.80   | -  |
| The drive detects <i>STPo</i> [Motor Step-Out Detected] fault when the load is not too high.                    | <ul style="list-style-type: none"> <li>• E5-09 [PM Back-EMF Vpeak (mV/(rad/s))]</li> <li>• E5-24 [PM Back-EMF L-L Vrms (mV/rpm)]</li> </ul> | <ul style="list-style-type: none"> <li>• Adjust the setting value.</li> <li>• Examine the motor code on the motor nameplate or the data sheet, then set correct values for E5-09 or E5-24.</li> </ul>  | *1   | <ul style="list-style-type: none"> <li>• Yaskawa motor<br/>Set the motor code from the motor nameplate.</li> <li>• Motor from another manufacturer<br/>Set the values from the test report.</li> </ul> |
| The drive detected stalling or <i>STPo</i> [Motor Step-Out Detected] at high speed and maximum output voltage.  | n8-62 [Output Voltage Limit Level]  | Set to a value lower than the actual input voltage.  | <ul style="list-style-type: none"> <li>• 200.0 V</li> <li>• 400.0 V</li> </ul>   | -  |



### 3.7 Fine Tuning during Test Runs (Adjust the Control Function)

\*1 The default setting changes when the settings for E5-01 [Motor Code Selection] and o2-04 [Drive Model (KVA) Selection] change.

#### ◆ Advanced Open Loop Vector Control Method for PM

Table 3.20 Parameters for Fine Tuning the Drive (A1-02 = 6[AOLV/PM])

| Issue  | Parameter Number  | Possible Solutions  | Default | Recommended Setting            |
|--|---|---|---------|--------------------------------|
| <ul style="list-style-type: none"> <li>Unsatisfactory motor torque and speed response</li> <li>Hunting or oscillation</li> </ul> | <ul style="list-style-type: none"> <li>High speed C5-01 [ASR Proportional Gain 1]</li> <li>Low speed C5-03 [ASR Proportional Gain 2]</li> </ul> | <ul style="list-style-type: none"> <li>If torque or speed response are slow, increase the setting value in increments of 5.00.</li> <li>If hunting or oscillation occur, decrease the setting value.</li> </ul> | 10.00   | 5.00 to 30.00 *1               |
|  | <ul style="list-style-type: none"> <li>High speed C5-02 [ASR Integral Time 1]</li> <li>Low speed C5-04 [ASR Integral Time 2]</li> </ul>         | <ul style="list-style-type: none"> <li>If torque or speed response are slow, decrease the setting value.</li> <li>If hunting or oscillation occur, increase the setting value.</li> </ul>                       | 0.500 s | 0.300 s to 1.000 s *1          |
| The drive cannot find ASR proportional gain or integral time for low speed or high speed.  | C5-07 [ASR Gain Switchover Frequency]   | Change the ASR proportional gain and ASR integral time to conform to the output frequency.  | 0.0%    | 0.0% to maximum rotation speed |
| Hunting or oscillation   | C5-06 [ASR Delay Time]  | If the rigidity of the machine is unsatisfactory and vibration is possible, increase the setting value in increments of 0.010.  | 0.016 s | 0.016 s to 0.035 s *1          |
| Step-out   | E1-xx parameters, E5-xx parameters  | Refer to the motor nameplate or test report and set E1-xx or E5-xx correctly.   | -       | -                              |

\*1 The best values for a no-load operation are different than the best values for actual loading operation.

#### ◆ Closed Loop Vector Control Method for PM

Table 3.21 Parameters for Fine Tuning the Drive (CLV/PM)

| Issue  | Parameter Number   | Possible Solutions  | Default   | Recommended Setting            |
|--|--|---|---|--------------------------------|
| <ul style="list-style-type: none"> <li>Unsatisfactory motor torque and speed response</li> <li>Hunting or oscillation</li> </ul> | <ul style="list-style-type: none"> <li>High speed C5-01 [ASR Proportional Gain 1]</li> <li>Low speed C5-03 [ASR Proportional Gain 2]</li> </ul>  | <ul style="list-style-type: none"> <li>If torque or speed response are slow, increase the setting value in increments of 5.00.</li> <li>If hunting or oscillation occur, decrease the setting value.</li> </ul> | 20.00   | 10.00 to 50.00 *1              |
|  | <ul style="list-style-type: none"> <li>High speed C5-02 [ASR Integral Time 1]</li> <li>Low speed C5-04 [ASR Integral Time 2]</li> </ul>  | <ul style="list-style-type: none"> <li>If torque or speed response are slow, decrease the setting value.</li> <li>If hunting or oscillation occur, increase the setting value.</li> </ul>                       | 0.500 s   | 0.300 to 1.000 s *1            |
| The drive cannot find speed response for low speed or high speed.  | <ul style="list-style-type: none"> <li>C5-07 [ASR Gain Switchover Frequency]</li> <li>High speed C5-01 [ASR Proportional Gain 1]</li> <li>C5-02 [ASR Integral Time 1]</li> <li>Low speed C5-03 [ASR Proportional Gain 2]</li> <li>C5-04 [ASR Integral Time 2]</li> </ul> | Change the ASR proportional gain and ASR integral time to conform to the output frequency.  | <ul style="list-style-type: none"> <li>C5-07 = 0.0 %</li> <li>C5-01 = 20.00</li> <li>C5-02 = 0.500 s</li> <li>C5-03 = 20.00</li> <li>C5-04 = 0.500 s</li> </ul> | 0.0% to maximum rotation speed |
| Hunting or oscillation   | C5-06 [ASR Delay Time]   | If the rigidity of the machine is unsatisfactory and vibration is possible, increase the setting value in increments of 0.010.  | 0.004 s   | 0.004 to 0.020 s *1            |
| Step-out   | E1-xx parameters, E5-xx parameters   | Refer to the motor nameplate or test report and set E1-xx or E5-xx correctly.   | -   | -                              |

\*1 The best values for a no-load operation are different than the best values for actual loading operation.

### 3.7 Fine Tuning during Test Runs (Adjust the Control Function)

#### ◆ EZ Open Loop Vector Control Method

Table 3.22 Parameters for Fine Tuning the Drive (A1-02 = 8[EZOLV])

| Issue  | Parameter Number  | Possible Solutions  | Default | Recommended Setting            |
|--|---|---|---------|--------------------------------|
| <ul style="list-style-type: none"> <li>Unsatisfactory motor torque and speed response</li> <li>Hunting or oscillation</li> </ul> | <ul style="list-style-type: none"> <li>High speed C5-01 [ASR Proportional Gain 1]</li> <li>Low speed C5-03 [ASR Proportional Gain 2]</li> </ul> | <ul style="list-style-type: none"> <li>If torque or speed response are slow, increase the setting value in increments of 5.00.</li> <li>If hunting or oscillation occur, decrease the setting value.</li> </ul> | 10.00   | 10.00 to 50.00 *1              |
|  | <ul style="list-style-type: none"> <li>High speed C5-02 [ASR Integral Time 1]</li> <li>Low speed C5-04 [ASR Integral Time 2]</li> </ul>         | <ul style="list-style-type: none"> <li>If torque or speed response are slow, decrease the setting value.</li> <li>If hunting or oscillation occur, increase the setting value.</li> </ul>                       | 0.500 s | 0.300 s to 1.000 s *1          |
| The drive cannot find ASR proportional gain or integral time for low speed or high speed.  | C5-07 [ASR Gain Switchover Frequency]   | Change the ASR proportional gain and ASR integral time to conform to the output frequency.  | 0.0%    | 0.0% to maximum rotation speed |
| Hunting or oscillation   | C5-06 [ASR Delay Time]  | If the rigidity of the machine is unsatisfactory and vibration is possible, increase the setting value in increments of 0.010.  | 0.004 s | 0.004 s to 0.020 s *1          |
| Step-out   | E9-xx parameters  | Refer to the motor nameplate or test report and set E9-xx correctly.  | -       | -                              |
| Oscillation when the motor starts.   | n8-51 [Accel / Decel Pull-In Current]   | Increase the setting value.   | 80%     | Increase in increments of 5%.  |
| Motor stalls.  | L7-01 to L7-04 [Torque Limit]   | Increase the setting value.   | 200%    | Increase in increments of 10%. |

\*1 The best values for a no-load operation are different than the best values for actual loading operation.

## 3.8 Test Run Checklist

Examine the items in this checklist and check each item before a test run.

| Checked | No. | Description  |
|---------|-----|--|
|         | 1   | Correctly install and wire the drive as specified by this manual.        |
|         | 2   | Energize the drive.  |
|         | 3   | Set the voltage for the power supply in E1-01 [Input AC Supply Voltage]. |

Check the applicable items as specified by your control method.

**WARNING! Sudden Movement Hazard.** Correctly wire the start/stop and safety circuits before you energize the drive. If you momentarily close a digital input terminal, it can start a drive that is programmed for 3-Wire control and cause serious injury or death from moving equipment.

**Table 3.23 V/f Control [A1-02 = 0] and Closed Loop V/f Control [A1-02 = 1]**

| Checked | No. | Description  |
|---------|-----|--|
|         | 4   | Select the best V/f pattern for your application and motor characteristics.<br>Example: For a motor with a rated frequency of 60 Hz, set E1-03 = 1 [V/f Pattern Selection = Const Trq, 60Hz base, 60Hz max] as a standard V/f pattern. |

**Table 3.24 Closed Loop V/f Control [A1-02 = 1]**

| Checked | No. | Description   |
|---------|-----|---|
|         | 5   | Set F1-01 [Encoder 1 Pulse Count (PPR)] correctly and make sure that encoder pulse counting direction is correct. |
|         | 6   | Set C5-01 [ASR Proportional Gain 1] and C5-02 [ASR Integral Time 1].  |

**Table 3.25 Open Loop Vector Control [A1-02 = 2] or Closed Loop Vector Control [A1-02 = 3]**

| Checked | No. | Description  |
|---------|-----|--|
|         | 7   | Decouple motor shafts and machines.  |
|         | 8   | Refer to the information on the motor nameplate and set this data correctly: <ul style="list-style-type: none"> <li>• Motor rated power (kW) to T1-02</li> <li>• Motor rated voltage (V) to T1-03</li> <li>• Motor rated current (A) to T1-04</li> <li>• Motor base frequency (Hz) to T1-05</li> <li>• Number of motor poles to T1-06</li> <li>• Motor base speed (min<sup>-1</sup>) to T1-07</li> </ul> |
|         | 9   | Do Rotational Auto-Tuning.   |

**Table 3.26 Closed Loop Vector Control [A1-02 = 3]**

| Checked | No. | Description   |
|---------|-----|---|
|         | 10  | Set F1-01 [Encoder 1 Pulse Count (PPR)] and F1-05 [Encoder 1 Rotation Selection]. |
|         | 11  | Set C5-01 [ASR Proportional Gain 1] and C5-02 [ASR Integral Time 1].              |

**Table 3.27 PM Open Loop Vector Control [A1-02 = 5]**

| Checked | No. | Description                                  |
|---------|-----|--|
|         | 12  | Set E5-01 through E5-24 [PM Motor Settings]. |

**Table 3.28 PM Advanced Open Loop Vector [A1-02 = 6]**

| Checked | No. | Description  |
|---------|-----|--|
|         | 13  | Set E5-01 through E5-24 [PM Motor Settings].                         |
|         | 14  | Set C5-01 [ASR Proportional Gain 1] and C5-02 [ASR Integral Time 1]. |

**Table 3.29 PM Closed Loop Vector Control [A1-02 = 7]**

| Checked | No. | Description  |
|---------|-----|--|
|         | 15  | Set E5-01 through E5-24 [PM Motor Settings].                         |
|         | 16  | Set C5-01 [ASR Proportional Gain 1] and C5-02 [ASR Integral Time 1]. |

### 3.8 Test Run Checklist

| Checked | No. | Description  |
|---------|-----|--|
|         | 17  | Set F1-01 [Encoder 1 Pulse Count (PPR)] and F1-05 [Encoder 1 Rotation Selection].  |
|         | 18  | Set E5-11 [Encoder Z-Pulse Offset].  |
| Checked | No. | Description  |
|         | 19  | The keypad will show "Rdy" after starting to operate the motor.  |
|         | 20  | To give the Run command and frequency reference from the keypad, push <b>LO/RE</b> to set to LOCAL Mode (when in LOCAL Mode, the LO/RE LED illuminates).   |
|         | 21  | If the motor rotates in the opposite direction during test run, switch two of the motor cables (U/T1, V/T2, W/T3).   |
|         | 22  | Set Heavy Duty or Normal Duty Mode with C6-01 [Normal / Heavy Duty Selection] to conform to the load condition.  |
|         | 23  | Set E2-01 [Motor Rated Current (FLA)] and L1-01 [Motor Overload Protection Select] correctly for motor thermal protection.   |
|         | 24  | Set the drive for REMOTE Mode when the control circuit terminals supply the Run command and frequency reference (in REMOTE Mode, the LO/RE LED turns OFF).   |
|         | 25  | <p>When terminal A1 is used for the frequency reference:</p> <ul style="list-style-type: none"> <li>• Voltage input <ul style="list-style-type: none"> <li>– Set DIP Switch S1-1 on the drive to "V".</li> <li>– Set H3-01 = 0, 1 [Terminal A1 Signal Level Select = 0 to 10V (Lower Limit at 0), -10 to +10V (Bipolar Reference)].</li> <li>– Set H3-02 = 0 [Terminal A1 Function Selection = Frequency Reference].</li> </ul> </li> <li>• Current input <ul style="list-style-type: none"> <li>– Set DIP Switch S1-1 on the drive to "I".</li> <li>– Set H3-01 = 2, 3 [Terminal A1 Signal Level Select = 4 to 20 mA, 0 to 20 mA].</li> <li>– Set H3-02 = 0 [Terminal A1 Function Selection = Frequency Reference].</li> </ul> </li> </ul>  |
|         | 26  | <p>When terminal A2 is used for the frequency reference:</p> <ul style="list-style-type: none"> <li>• Voltage input <ul style="list-style-type: none"> <li>– Set DIP Switch S1-2 on the drive to "V".</li> <li>– Set H3-09 = 0, 1 [Terminal A2 Signal Level Select = 0 to 10V (Lower Limit at 0), -10 to 10 V (Bipolar Reference)].</li> <li>– Set H3-10 = 0 [Terminal A2 Function Selection = Frequency Reference].</li> </ul> </li> <li>• Current input <ul style="list-style-type: none"> <li>– Set DIP Switch S1-2 on the drive to "I".</li> <li>– Set H3-09 = 2, 3 [Terminal A2 Signal Level Select = 4 to 20 mA, 0 to 20 mA].</li> <li>– Set H3-10 = 0 [Terminal A2 Function Selection = Frequency Reference].</li> </ul> </li> </ul>  |
|         | 27  | <p>When terminal A3 is used for the frequency reference:</p> <ul style="list-style-type: none"> <li>• Voltage input <ul style="list-style-type: none"> <li>– Set DIP Switch S4 on the drive to analog input side.</li> <li>– Set DIP Switch S1-3 on the drive to "V".</li> <li>– Set H3-05 = 0, 1 [Terminal A3 Signal Level Select = 0 to 10V (Lower Limit at 0), -10 to +10V (Bipolar Reference)].</li> <li>– Set H3-06 = 0 [Terminal A3 Function Selection = Frequency Reference].</li> </ul> </li> <li>• Current input <ul style="list-style-type: none"> <li>– Set DIP Switch S4 on the drive to analog input side.</li> <li>– Set DIP Switch S1-3 on the drive to "I".</li> <li>– Set H3-05 = 2, 3 [Terminal A3 Signal Level Select = 4 to 20 mA (Lower Limit at 4), 0 to 20 mA (Bipolar Reference)].</li> <li>– Set H3-06 = 0 [Terminal A3 Function Selection = Frequency Reference].</li> </ul> </li> </ul> |
|         | 28  | <p>Make sure that the frequency reference reaches the necessary minimum and maximum values.<br/> → If drive operation is incorrect, make these adjustments:<br/> Gain adjustment: Set the maximum voltage and current values, then adjust the analog input gain until the frequency reference reaches the necessary value. (For terminal A1 input: H3-03, for terminal A2 input: H3-11, for terminal A3 input: H3-07)<br/> Bias adjustment: Set the maximum voltage/current values, then adjust the analog input bias until the frequency reference reaches the necessary minimum value. (For terminal A1 input: H3-04, for terminal A2 input: H3-12, for terminal A3 input: H3-08)</p>  |

## Mechanical & Electrical Installation

---

This chapter explains how to properly mount and install the drive, and to wire the control circuit terminals, motor, and power supply.

|            |  |            |
|------------|--|------------|
| <b>4.1</b> | <b>Section Safety .....</b>              | <b>618</b> |
| <b>4.2</b> | <b>Removing/Reattaching Covers .....</b> | <b>622</b> |
| <b>4.3</b> | <b>Electrical Installation .....</b>     | <b>627</b> |
| <b>4.4</b> | <b>Main Circuit Wiring .....</b>         | <b>631</b> |
| <b>4.5</b> | <b>Control Circuit Wiring .....</b>      | <b>633</b> |
| <b>4.6</b> | <b>Control I/O Connections .....</b>     | <b>642</b> |
| <b>4.7</b> | <b>Connect the Drive to a PC .....</b>   | <b>646</b> |

## 4.1 Section Safety

### DANGER

#### Electrical Shock Hazard

**Do not examine, connect, or disconnect wiring on an energized drive. Before servicing, disconnect all power to the equipment and wait for the time specified on the warning label at a minimum. The internal capacitor stays charged after the drive is de-energized. The charge indicator LED extinguishes when the DC bus voltage decreases below 50 Vdc. When all indicators are OFF, remove the covers before measuring for dangerous voltages to make sure that the drive is safe.**

If you do work on the drive when it is energized, it will cause serious injury or death from electrical shock. The drive has internal capacitors that stay charged after you de-energize the drive.

### WARNING

#### Electrical Shock Hazard

**Do not operate the drive when covers are missing. Replace covers and shields before you operate the drive. Use the drive only as specified by the instructions.**

Some figures in this section include drives without covers or safety shields to more clearly show the inside of the drive. If covers or safety shields are missing from the drive, it can cause serious injury or death.

**Ground the neutral point on the power supply of drive models 2xxxB/C and 4xxxA/B/C to comply with the EMC Directive before you turn on the EMC filter.**

If you turn ON the EMC filter, but you do not ground the neutral point, it can cause serious injury or death.

**Make sure that the protective ground wire conforms to technical standards and local safety regulations. The IEC/EN 61800-5-1:2007 standard specifies that you must wire the power supply to automatically de-energize when the protective ground wire disconnects. You can also connect a protective ground wire that has a minimum cross-sectional area of 10 mm<sup>2</sup> (copper wire) or 16 mm<sup>2</sup> (aluminum wire).**

If you do not obey the standards and regulations, it can cause serious injury or death. The leakage current of the drive will be more than 3.5 mA in drive models 2xxxB, 2xxxC, 4002B to 4371B, 4002C to 4371C (with built-in EMC filter turned ON) and 4414 to 4720.

**Make sure that the protective ground wire conforms to technical standards and local safety regulations. The IEC/EN 61800-5-1:2007 standard specifies that you must wire the power supply to automatically de-energize when the protective ground wire disconnects. You can also connect a protective ground wire that has a minimum cross-sectional area of 10 mm<sup>2</sup> (copper wire) or 16 mm<sup>2</sup> (aluminum wire).**

If you do not obey the standards and regulations, it can cause serious injury or death. The leakage current of the drive will be more than 3.5 mA in drive models 2xxxB, 2xxxC, 4002B to 4371B, 4002C to 4371C (with EMC filter activated) and 4389 to 4675.

**When a residual current operated protective or monitoring device prevents direct or indirect contact, always use a type B Ground Fault Circuit Interrupter (GFCI) as specified by IEC/EN 60755.**

If you do not use the correct GFCI, it can cause serious injury or death. The drive can cause a residual current with a DC component in the protective earthing conductor.

**When there is a DC component in the protective earthing conductor, the drive can cause a residual current. When a residual current operated protective or monitoring device prevents direct or indirect contact, always use a type B Residual Current Monitor/Residual Current Device (RCM/RCD) as specified by IEC/EN 60755.**

If you do not use the correct RCM/RCD, it can cause serious injury or death.

**When there is a DC component in the protective earthing conductor, the drive can cause a residual current. When a residual current operated protective or monitoring device prevents direct or indirect contact, always use a type B Earth Leakage Circuit Breaker (ELCB) as specified by IEC/EN 60755.**

If you do not use the correct ELCB, it can cause serious injury or death.

**⚠ WARNING**

**Do not wear loose clothing or jewelry when you do work on the drive. Tighten loose clothing and remove all metal objects, for example watches or rings.**

Loose clothing can catch on the drive and jewelry can conduct electricity and cause serious injury or death.

**Do not remove covers or touch circuit boards while the drive is energized.**

If you touch the internal components of an energized drive, it can cause serious injury or death.

**Only let approved personnel install, wire, maintain, examine, replace parts, and repair the drive.**

If personnel are not approved, it can cause serious injury or death.

**Electrical Shock Hazard.**

**Do not modify the drive body or drive circuitry.**

Modifications to drive body and circuitry can cause serious injury or death, will cause damage to the drive, and will void the warranty. Yaskawa is not responsible for modifications of the product made by the user.

**Fire Hazard**

**Tighten all terminal screws to the correct tightening torque.**

Connections that are too loose or too tight can cause incorrect operation and damage to the drive. Incorrect connections can also cause death or serious injury from fire.

**Tighten screws at an angle in the specified range shown in this manual.**

If you tighten the screws at an angle not in the specified range, you can have loose connections that can cause damage to the terminal block or start a fire and cause serious injury or death.

**Do not put flammable or combustible materials on top of the drive and do not install the drive near flammable or combustible materials. Attach the drive to metal or other noncombustible material.**

Flammable and combustible materials can start a fire and cause serious injury or death.

**Do not use the main circuit power supply (Overvoltage Category III) at incorrect voltages. Operate the drive in the specification range of the input voltage on the drive nameplate.**

Voltages that are higher than the permitted nameplate tolerance can cause damage to the drive.

**When you install a dynamic braking option, wire the components as specified by the wiring diagrams.**

Incorrect wiring can cause damage to braking components or serious injury or death.

**When you install the drive in an enclosure, use a cooling fan or cooler to decrease the temperature around the drive. Make sure that the intake air temperature to the drive is 50 °C (122 °F) or less for IP20 open chassis type drives, and 40 °C (104 °F) or less for UL Type 1 enclosed wall-mounted drives.**

If the air temperature is too hot, the drive can become too hot and cause a fire and serious injury or death.

**Crush Hazard**

**Only approved personnel can operate a crane or hoist to move the drive.**

If unapproved personnel operate a crane or hoist, it can cause serious injury or death from falling equipment.

**Before you hang the drive vertically, use screws to correctly attach the drive front cover and other drive components.**

If you do not secure the front cover, it can fall and cause minor injury.

**When you use a crane or hoist to lift the drive during installation or removal, prevent more than 1.96 m/s<sup>2</sup> (0.2 G) vibration or impact.**

Too much vibration or impact can cause serious injury or death from falling equipment.

**⚠ WARNING**

**When you lift the drive during installation or removal, do not try to turn the drive over and do not ignore the hanging drive.**

If you move a hanging drive too much or if you ignore it, the drive can fall and cause serious injury or death.

**Use a crane or hoist to move large drives when necessary.**

If you try to move a large drive without a crane or hoist, it can cause serious injury or death.

**⚠ CAUTION**

**Crush Hazard**

**Tighten terminal cover screws and hold the case safely when you move the drive.**

If the drive or covers fall, it can cause moderate injury.

**NOTICE**

**Do not let unwanted objects, for example metal shavings or wire clippings, fall into the drive during drive installation. Put a temporary cover over the drive during installation. Remove the temporary cover before start-up.**

Unwanted objects inside of the drive can cause damage to the drive.

**Obey correct electrostatic discharge (ESD) procedures when you touch the drive.**

Incorrect ESD procedures can cause damage to the drive circuitry.

**Select a motor that is compatible with the load torque and speed range. When 100% continuous torque is necessary at low speed, use an inverter-duty motor or vector-duty motor. When you use a standard fan-cooled motor, decrease the motor torque in the low-speed range.**

If you operate a standard fan-cooled motor at low speed and high torque, it will decrease the cooling effects and can cause heat damage.

**Obey the speed range specification of the motor as specified by the manufacturer. When you must operate the motor outside of its specifications, contact the motor manufacturer.**

If you continuously operate oil-lubricated motors outside of the manufacturer specifications, it can cause damage to the motor bearings.

**When the input voltage is 440 V or higher or the wiring distance is longer than 100 m (328 ft), make sure that the motor insulation voltage is sufficient or use an inverter-duty motor or vector-duty motor with reinforced insulation.**

Motor winding and insulation failure can occur.

**Install vibration-proof rubber on the base of the motor or use the frequency jump function in the drive to prevent specific frequencies that vibrate the motor.**

Motor or system resonant vibration can occur in fixed speed machines that are converted to variable speed. Too much vibration can cause damage to equipment.

**You can use the drive with an explosion-proof motor, but the drive is not explosion-proof. Install the drive only in the environment shown on the nameplate.**

If you install the drive in a dangerous environment, it can cause damage to the drive.

**Do not lift the drive with the covers removed.**

If the drive does not have covers, you can easily cause damage to the internal parts of the drive.



**NOTICE**

**Before you connect a dynamic braking option to the drive, make sure that qualified personnel read and obey the Braking Unit and Braking Resistor Unit Installation Manual (TOBPC72060001).**

If you do not read and obey the manual or if personnel are not qualified it can cause damage to the drive and braking circuit.

**Make sure that all connections are correct after you install the drive and connect peripheral devices.**

Incorrect connections can cause damage to the drive.

**Note:**

- The motor may require more acceleration torque with drive operation than with a commercial power supply. Check the load torque characteristics of the machine to be used with the motor.
- The rated input current of submersible motors is higher than the rated input current of standard motors. Carefully select the correct drive capacity. When the distance between the motor and drive is long, use a wire that can connect the motor to the drive without a reduction in motor torque.
- Do not use unshielded wire for control wiring. Use shielded, twisted-pair wires and ground the shield to the ground terminal of the drive. Unshielded wire can cause electrical interference and unsatisfactory system performance.

## 4.2 Removing/Reattaching Covers

This section gives information about how to remove and reattach the front cover and terminal cover for wiring and inspection.

Different drive models have different procedures to remove and reattach the covers. Refer to Table 4.1 for more information.

**Table 4.1 Procedures to Remove Covers by Drive Model**

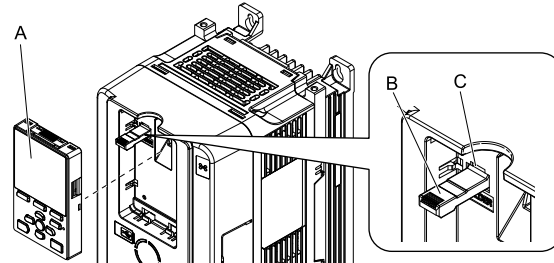
| Model                      | Procedure   | Reference |
|----------------------------|-------------|-----------|
| 2004 - 2211<br>4002 - 4168 | Procedure A | 622       |
| 2257 - 2415<br>4208 - 4720 | Procedure B | 623       |

### ◆ Removing/Reattaching the Cover Using Procedure A

**DANGER! Electrical Shock Hazard.** Do not examine, connect, or disconnect wiring on an energized drive. Before servicing, disconnect all power to the equipment and wait for the time specified on the warning label at a minimum. The internal capacitor stays charged after the drive is de-energized. The charge indicator LED extinguishes when the DC bus voltage decreases below 50 Vdc. When all indicators are OFF, remove the covers before measuring for dangerous voltages to make sure that the drive is safe. If you do work on the drive when it is energized, it will cause serious injury or death from electrical shock. The drive has internal capacitors that stay charged after you de-energize the drive.

#### ■ Remove the Front Cover

1. Remove the keypad and remove the keypad connector, then insert the end of the keypad connector that has the tab into the keypad connector holder on the front cover.

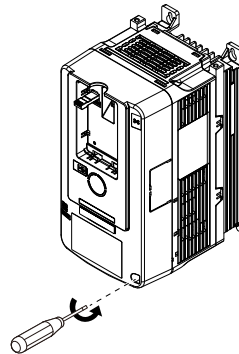


A - Keypad  
B - Keypad connector

C - Holder

**Figure 4.1 Remove the Keypad and Keypad Connector**

2. Loosen the front cover screw.



**Figure 4.2 Loosen the Front Cover Screw**

3. Push on the tab in the side of the front cover then pull the front cover forward to remove it from the drive.

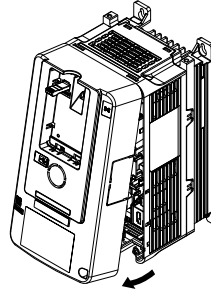


Figure 4.3 Remove the Front Cover

### ■ Reattach the Front Cover

1. Wire the drive and other peripheral devices.
2. Reverse the steps to reattach the cover.

**Note:**

- Wire the grounding terminals first, main circuit terminals next, and control circuit terminals last.
- Make sure that you do not pinch wires or signal lines between the front cover and the drive before you reattach the cover.
- Tighten the screws to a tightening torque of 0.98 N·m to 1.33 N·m (8.67 lb·in. to 11.77 lb·in.).

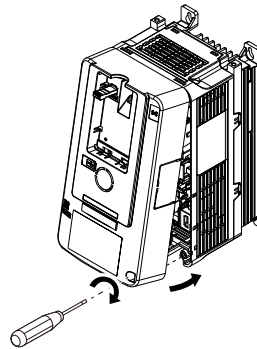


Figure 4.4 Reattach the Front Cover

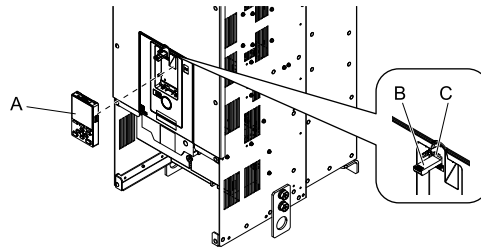
3. Reattach the keypad to the original position.

### ◆ Removing/Reattaching the Cover Using Procedure B

**DANGER! Electrical Shock Hazard.** Do not examine, connect, or disconnect wiring on an energized drive. Before servicing, disconnect all power to the equipment and wait for the time specified on the warning label at a minimum. The internal capacitor stays charged after the drive is de-energized. The charge indicator LED extinguishes when the DC bus voltage decreases below 50 Vdc. When all indicators are OFF, remove the covers before measuring for dangerous voltages to make sure that the drive is safe. If you do work on the drive when it is energized, it will cause serious injury or death from electrical shock. The drive has internal capacitors that stay charged after you de-energize the drive.

■ **Remove the Front Cover**

1. Remove the terminal cover, keypad, and keypad connector, then insert the end of the keypad connector that has the tab into the keypad connector holder on the front cover.



A - Keypad  
B - Keypad connector

C - Connector holder

Figure 4.5 Remove the Terminal Cover, Keypad, and Keypad Connector

2. Loosen the front cover screws.

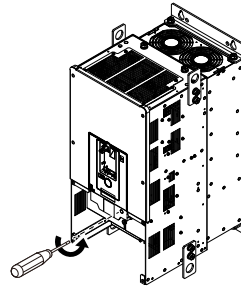
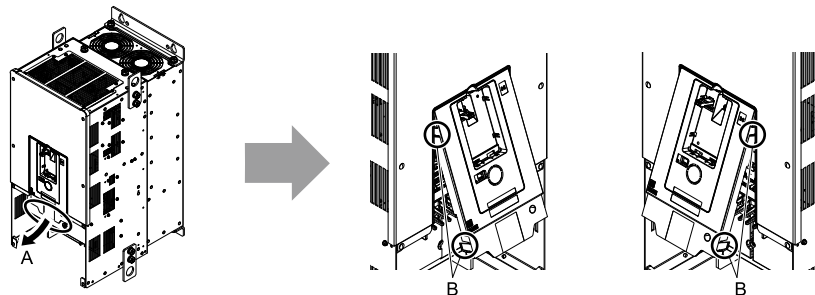


Figure 4.6 Loosen the Front Cover Screws

3. Push on the four tabs found on each side of the front cover, then pull the front cover forward to remove it from the drive.



A - Pull forward to remove the front cover.

B - Unhook the tabs found on the sides of the front cover.

Figure 4.7 Pull Forward to Remove the Front Cover

4. Remove the front cover from the drive.

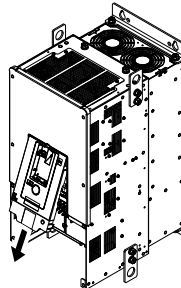


Figure 4.8 Remove the Front Cover

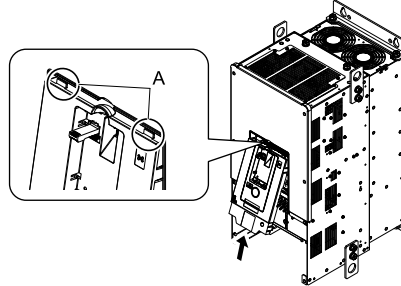
### ■ Reattach the Front Cover

Wire the drive and other peripheral devices then reattach the front cover.

**Note:**

Wire the grounding terminals first, main circuit terminals next, and control circuit terminals last.

1. Move the front cover to connect the hooks at the top of the front cover to the drive.



A - Hooks

Figure 4.9 Reattach the Front Cover

2. Move the front cover until it clicks into position while pushing on the hooks on the left and right sides of the front cover.

**Note:**

Make sure that you do not pinch wires or signal lines between the front cover and the drive before you reattach the cover.

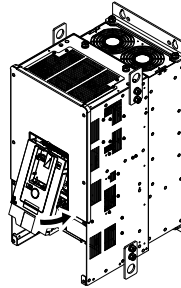


Figure 4.10 Reattach the Front Cover

3. Reattach the keypad to the original position.

### ■ Remove the Terminal Cover

1. Loosen the screws on the terminal cover, then pull down on the cover.

**CAUTION!** *Crush Hazard. Loosen the cover screws. Do not fully remove them. If you fully remove the cover screws, the terminal cover can fall and cause moderate injury.*

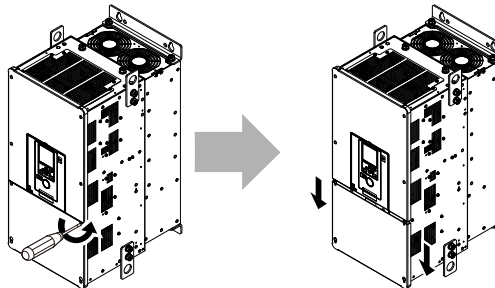


Figure 4.11 Loosen the Terminal Cover Mounting Screws

## 4.2 Removing/Reattaching Covers

---

2. Pull the terminal cover away from the drive.

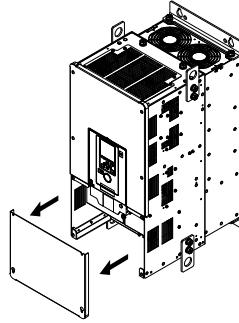


Figure 4.12 Remove the Terminal Cover

### ■ Reattach the Terminal Cover

Wire the drive and other peripheral devices then reattach the terminal cover.

**Note:**

- Wire the grounding terminals first, main circuit terminals next, and control circuit terminals last.
- Make sure that you do not pinch wires or signal lines between the wiring cover and the drive before you reattach the cover.
- Tighten the screws to a tightening torque of 0.98 N·m to 1.33 N·m (8.67 lb·in. to 11.77 lb·in.).

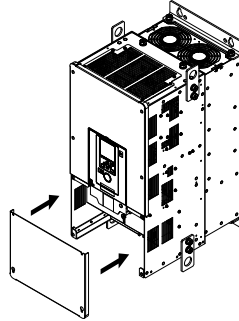


Figure 4.13 Reattach the Terminal Cover

## 4.3 Electrical Installation

**DANGER!** *Electrical Shock Hazard. Do not examine, connect, or disconnect wiring on an energized drive. Before servicing, disconnect all power to the equipment and wait for the time specified on the warning label at a minimum. The internal capacitor stays charged after the drive is de-energized. The charge indicator LED extinguishes when the DC bus voltage decreases below 50 Vdc. When all indicators are OFF, remove the covers before measuring for dangerous voltages to make sure that the drive is safe. If you do work on the drive when it is energized, it will cause serious injury or death from electrical shock. The drive has internal capacitors that stay charged after you de-energize the drive.*

**WARNING!** *Electrical Shock Hazard. Make sure that all electrical connections are correct and install all drive covers before you energize the drive. Use terminals for their correct function only. Incorrect wiring connections and incorrect cover installation can cause serious injury or death.*

**WARNING!** *Electrical Shock Hazard.. Correctly ground the drive before you turn on the EMC filter switch. If you touch electrical equipment that is not grounded, it can cause serious injury or death.*

**WARNING!** *Electrical Shock Hazard. Use the terminals for the drive only for their intended purpose. Refer to the technical manual for more information about the I/O terminals. Wiring and grounding incorrectly or modifying the cover may damage the equipment or cause injury.*

### ◆ Standard Connection Diagram

Wire the drive as specified by Figure 4.14.

**WARNING!** *Sudden Movement Hazard. Set the MFDI parameters before you close control circuit switches. Incorrect Run/Stop circuit sequence settings can cause serious injury or death from moving equipment.*

**WARNING!** *Sudden Movement Hazard. Correctly wire the start/stop and safety circuits before you energize the drive. If you momentarily close a digital input terminal, it can start a drive that is programmed for 3-Wire control and cause serious injury or death from moving equipment.*

**WARNING!** *Sudden Movement Hazard. When you use a 3-Wire sequence, set A1-03 = 3330 [Initialize Parameters = 3-Wire Initialization] and make sure that b1-17 = 0 [Run Command at Power Up = Disregard Existing RUN Command] (default). If you do not correctly set the drive parameters for 3-Wire operation before you energize the drive, the motor can suddenly rotate in reverse when you energize the drive.*

**WARNING!** *Sudden Movement Hazard. Check the I/O signals and the external sequences for the drive before you set the Application Preset function. When you set the Application Preset function (A1-06 ≠ 0), it changes the I/O terminal functions for the drive and it can cause equipment to operate unusually. This can cause serious injury or death.*

**WARNING!** *Fire Hazard. Install sufficient branch circuit short circuit protection as specified by applicable codes and this manual. The drive is suited for circuits that supply not more than 100,000 RMS symmetrical amperes, 240 Vac maximum (200 V Class), 480 Vac maximum (400 V Class). Incorrect branch circuit short circuit protection can cause serious injury or death.*

**NOTICE:** *When the input voltage is 440 V or higher or the wiring distance is longer than 100 m (328 ft), make sure that the motor insulation voltage is sufficient or use an inverter-duty motor or vector-duty motor with reinforced insulation. Motor winding and insulation failure can occur.*

**Note:**

Do not connect the AC control circuit ground to the drive enclosure. Failure to obey can cause incorrect control circuit operation.

### 4.3 Electrical Installation

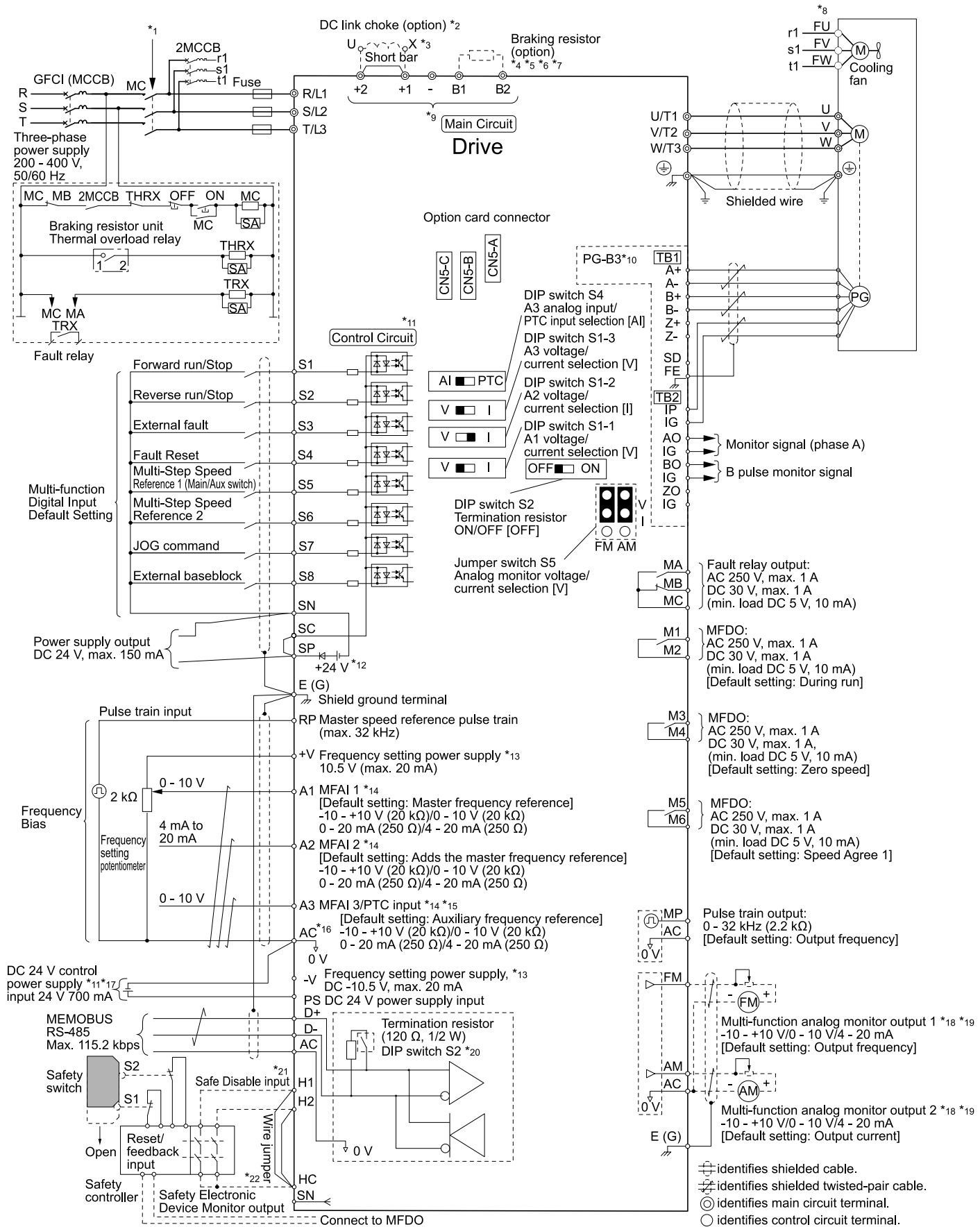


Figure 4.14 Standard Drive Connection Diagram



- \*1 Set the wiring sequence to de-energize the drive with the fault relay output. If the drive outputs a fault during fault restart when you use the fault restart function, set  $L5-02 = 1$  [*Fault Contact at Restart Select = Always Active*] to de-energize the drive. Be careful when you use a cut-off sequence. The default setting for  $L5-02$  is  $0$  [*Active Only when Not Restarting*].
- \*2 When you install a DC link choke, you must remove the jumper between terminals +1 and +2.
- \*3 Models 2110 to 2415 and 4060 to 4720 have a DC link choke.
- \*4 When you use a regenerative converter, regenerative unit, or braking unit, set  $L8-55 = 0$  [*Internal DB Transistor Protection = Disable*]. If  $L8-55 = 1$  [*Protection Enabled*], the drive will detect  $rF$  [*Braking Resistor Fault*].
- \*5 When you use a regenerative converter, regenerative unit, braking unit, braking resistor, or braking resistor unit, set  $L3-04 = 0$  [*Stall Prevention during Decel = Disabled*] If  $L3-04 = 1$  [*General Purpose*], the drive could possibly not stop in the specified deceleration time.
- \*6 When you use an ERF-type braking resistor, set  $L8-01 = 1$  [*3% ERF DB Resistor Protection = Enabled*] and set a wiring sequence to de-energize the drive with the fault relay output.
- \*7 When you connect a braking unit (CDBR series) or a braking resistor unit (LKEB series) to drive models 2110, 2138, and 4103, make sure that you use wires that are in the range of the applicable gauges for the drive. A junction terminal is necessary to connect wires that are less than the applicable gauge to the drive. Contact Yaskawa or your nearest sales representative for more information about selection and installation of the junction terminal.
- \*8 Cooling fan wiring is not necessary for self-cooling motors.
- \*9 Connect peripheral options to terminals -, +1, +2, B1, and B2.  
**WARNING!** *Electrical Shock Hazard. Only connect factory-recommended devices or circuits to drive terminals B1, B2, -, +1, +2, and +3 terminals. Do not connect AC power to these terminals. Incorrect wiring can cause damage to the drive and serious injury or death from fire.*
- \*10 Encoder circuit wiring (wiring to PG-B3 option card) is not necessary for applications that do not use motor speed feedback.
- \*11 Connect a 24 V power supply to terminals PS-AC to operate the control circuit while the main circuit power supply is OFF.
- \*12 Install the wire jumpers between terminals SC-SP and SC-SN to set the MFDI power supply (sinking/sourcing mode or internal/external power supply).  
**NOTICE:** *Do not close the circuit between terminals SP and SN. Failure to obey will cause damage to the drive.*
  - Sinking Mode: Install a jumper between terminals SC and SP.  
**NOTICE:** *Do not close the circuit between terminals SC and SN. A closed circuit between these terminals will cause damage to the drive.*
  - Sourcing Mode: Install a jumper between terminals SC and SN.  
**NOTICE:** *Do not close the circuit between terminals SC and SP. A closed circuit between these terminals will cause damage to the drive.*
  - External power supply: No jumper necessary between terminals SC-SN and terminals SC-SP.
- \*13 The maximum output current capacity for terminals +V and -V on the control circuit is 20 mA.  
**NOTICE:** *Do not install a jumper between terminals +V, -V, and AC. Failure to obey can cause damage to the drive.*
- \*14 DIP switches S1-1 to S1-3 set terminals A1 to A3 for voltage or current input. The default setting for S1-1 and S1-3 is voltage input ("V" side). The default setting for S1-2 is current input ("I" side).
- \*15 DIP switch S4 sets terminal A3 for analog or PTC input. Set DIP switch S1-3 to the "V" side, and set  $H3-05 = 0$  [*Terminal A3 Signal Level Select = 0 to 10V (Lower Limit at 0)*] to set terminal A3 for PTC input with DIP switch S4.
- \*16 Do not ground the control circuit terminals AC or connect them to the drive.  
**NOTICE:** *Do not ground the AC control circuit terminals and only connect the AC terminals according to the product instructions. If you connect the AC terminals incorrectly, it can cause damage to the drive.*
- \*17 Connect the positive lead from an external 24 Vdc power supply to terminal PS and the negative lead to terminal AC.  
**NOTICE:** *Connect terminals PS and AC correctly for the 24 V power supply. If you connect the wires to the incorrect terminals, it will cause damage to the drive.*
- \*18 Use multi-function analog monitor outputs with analog frequency meters, ammeters, voltmeters, and wattmeters. Do not use monitor outputs with feedback-type signal devices.

### 4.3 Electrical Installation

---

- \*19 Jumper switch S5 sets terminal FM and AM for voltage or current output. The default setting for S5 is voltage output (“V” side).
- \*20 Set DIP switch S2 to “ON” to enable the termination resistor in the last drive in a MEMOBUS/Modbus network.
- \*21 Use only SOURCE Mode for Safe Disable input.
- \*22 Disconnect the wire jumpers between H1 and HC and H2 and HC to use the Safe Disable input.

## 4.4 Main Circuit Wiring

This section gives information about the functions, specifications, and procedures necessary to safely and correctly wire the main circuit in the drive.

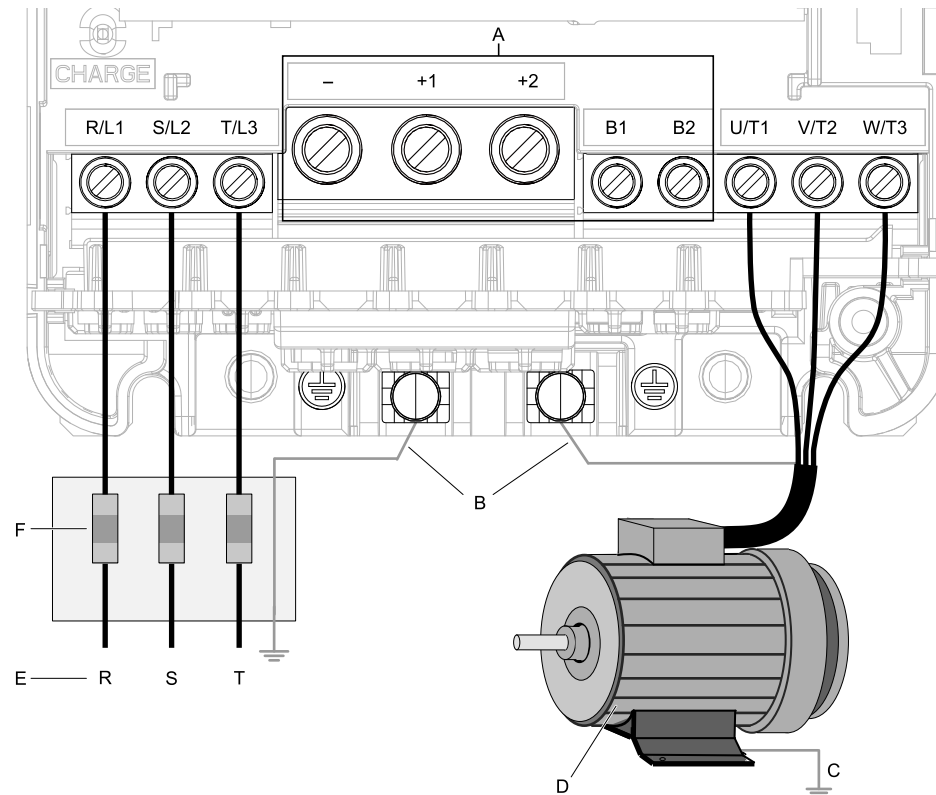
**NOTICE:** The drive can fail if users frequently turn the drive ON and OFF with the MC on the power source side to Run and Stop the drive. Incorrect operation can decrease the service life of the relay contacts and electrolytic capacitors. If you frequently use the magnetic contactor on the power source side to Run and Stop the drive, it can cause drive failure.

**Note:**

Soldered wire connections can become loose over time and cause unsatisfactory drive performance.

### ◆ Motor and Main Circuit Connections

**WARNING!** Electrical Shock Hazard. Do not connect terminals R/L1, S/L2, T/L3, U/T1, V/T2, W/T3, -, +1, +2, +3, B1, or B2 to the ground terminal. If you connect these terminals to earth ground, it can cause damage to the drive or serious injury or death.



- A - DC bus terminal
- B - Connect to the drive ground terminal.
- C - Ground the motor case.
- D - Three-Phase Motor
- E - Use R, S, T for input power supply.
- F - Input Protection (Fuses or Circuit Breakers)

**Note:**

The location of terminals are different for different drive models.


Figure 4.15 Wiring the Main Circuit and Motor

### ◆ Main Circuit Terminal Functions

Refer to Table 4.2 for the functions of drive main circuit terminals.

## 4.4 Main Circuit Wiring

**Table 4.2 Main Circuit Terminal Functions**

| Terminals  | Name  |                                  |  |             | Function  |
|--|---|----------------------------------|--|-------------|---|
|  | 2004 - 2082   | 2110 - 2138                      | 2169 - 2415  | -           |   |
| Model  | 4002 - 4044   | 4060 - 4168                      | 4208 - 4414  | 4477 - 4720 |   |
| R/L1   | Main circuit power supply input   |                                  |  |             | To connect a commercial power supply.   |
| S/L2   |   |                                  |  |             |   |
| T/L3   |   |                                  |  |             |   |
| U/T1   | Drive output  |                                  |  |             | To connect a motor.   |
| V/T2   |   |                                  |  |             |   |
| W/T3   |   |                                  |  |             |   |
| B1   | Braking resistor connection   |                                  | -  |             | To connect a braking resistor or braking resistor unit.   |
| B2   |   |                                  |  |             |   |
| +2   | <ul style="list-style-type: none"> <li>DC power supply input (+1 and -)</li> <li>DC reactor connection (+1 and +2)</li> </ul>                                   | DC power supply input (+1 and -) | -  |             | To connect peripheral devices, for example: <ul style="list-style-type: none"> <li>DC power input</li> <li>Braking unit</li> <li>DC link choke</li> </ul> <b>Note:</b><br>Remove the jumper between terminals +1 and +2 to connect a DC link choke. |
| +1   |   |                                  |  |             |   |
| -  |   |                                  |  |             |   |
| +3   | -   |                                  | <ul style="list-style-type: none"> <li>DC power supply input (+1 and -)</li> <li>Braking unit connection (+3 and -)</li> </ul> |             |   |
|  | <ul style="list-style-type: none"> <li>200 V: D class grounding (ground to 100 Ω or less)</li> <li>400 V: C class grounding (ground to 10 Ω or less)</li> </ul> |                                  |  |             | To ground the drive.  |

**Note:**

Use terminals B1 and - to connect a CDBR-type control unit to drive models 2004 to 2138 and 4002 to 4168 that have built-in braking transistors.

## 4.5 Control Circuit Wiring

This section gives information about wiring the control circuit.

### ◆ Control Circuit Connection Diagram

Wire the drive control circuit as shown in Figure 4.16.

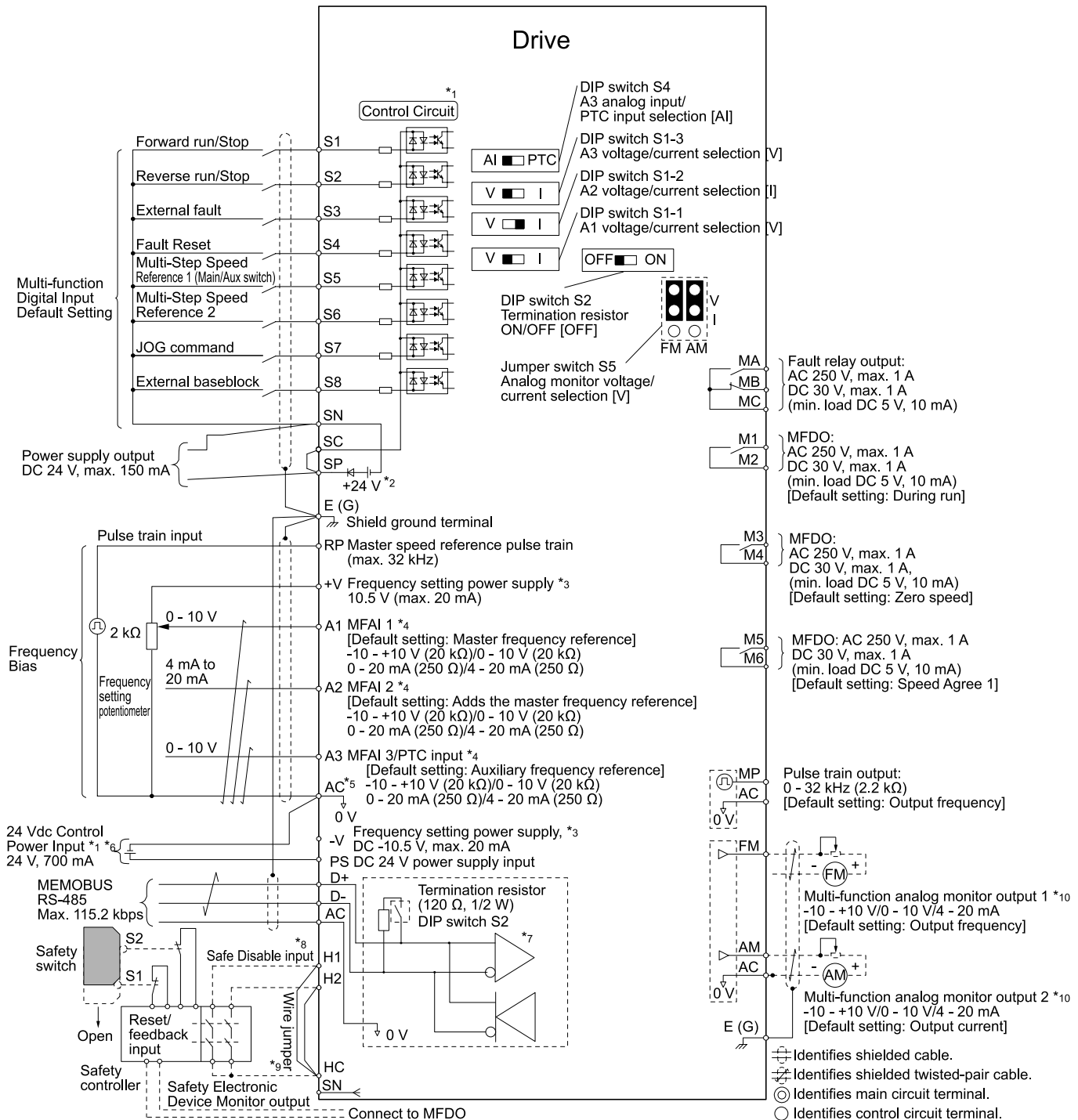


Figure 4.16 Control Circuit Connection Diagram

\*1 To operate the control circuit while the main circuit power supply is OFF, connect a 24 V power supply unit (option).

## 4.5 Control Circuit Wiring

---

- \*2 Install the wire jumpers between terminals SC-SP and SC-SN to set the MFDI power supply (sinking/sourcing mode or internal/external power supply).  
**NOTICE:** Do not close the circuit between terminals SP and SN. Failure to obey will cause damage to the drive.
  - Sinking Mode: Install a jumper between terminals SC and SP.  
**NOTICE:** Do not close the circuit between terminals SC and SN. A closed circuit between these terminals will cause damage to the drive.
  - Sourcing Mode: Install a jumper between terminals SC and SN.  
**NOTICE:** Do not close the circuit between terminals SC and SP. A closed circuit between these terminals will cause damage to the drive.
  - External Power Supply: No jumper necessary between terminals SC-SN and terminals SC-SP.
- \*3 The output current capacity of the +V and -V terminals on the control circuit is 20 mA.  
**NOTICE:** Do not install a jumper between terminals +V, -V, and AC. Failure to obey can cause damage to the drive.
- \*4 Set DIP switches S1-1 to S1-3 to select between a voltage or current input signal to terminals A1 to A3. The default setting for S1-1 and S1-3 is voltage input (“V” side). The default setting for S1-2 is current input (“I” side).
- \*5 Do not ground the control circuit terminals AC or connect them to the drive.  
**NOTICE:** Do not ground the AC control circuit terminals and only connect the AC terminals according to the product instructions. If you connect the AC terminals incorrectly, it can cause damage to the drive.
- \*6 Do not connect terminals PS and AC inversely. Failure to obey will cause damage to the drive.
- \*7 Set DIP switch S2 to the ON position to enable the termination resistor in the last drive in a MEMOBUS/Modbus communications.
- \*8 To use the internal power supply with the Safe Disable input, use sourcing mode.
- \*9 Disconnect the wire jumpers between H1 and HC and H2 and HC to use the Safe Disable input.
- \*10 Use multi-function analog monitor outputs with analog frequency meters, ammeters, voltmeters, and wattmeters. Do not use monitor outputs with feedback-type signal devices.

---

### ◆ Control Circuit Terminal Block Functions

*Hx-xx parameters* set functions for the multi-function input and output terminals.

**WARNING!** Sudden Movement Hazard. Correctly wire and test all control circuits to make sure that the control circuits operate correctly. If you use a drive that has incorrect control circuit wiring or operation, it can cause death or serious injury.

**WARNING!** Sudden Movement Hazard. Check the I/O signals and the external sequences for the drive before you set the Application Preset function. When you set the Application Preset function ( $A1-06 \neq 0$ ), it changes the I/O terminal functions for the drive and it can cause equipment to operate unusually. This can cause serious injury or death.

**NOTICE:** The drive can fail if users frequently turn the drive ON and OFF with the MC on the power source side to Run and Stop the drive. Incorrect operation can decrease the service life of the relay contacts and electrolytic capacitors. If you frequently use the magnetic contactor on the power source side to Run and Stop the drive, it can cause drive failure.

### ■ Input Terminals

Refer to Table 4.3 for a list of input terminals and functions.

Table 4.3 Multi-function Input Terminals

| Type                       | Terminal                  | Name (Default)   | Function (Signal Level)  |
|----------------------------|---------------------------|--|--|
| Digital Inputs             | S1                        | MFDI selection 1<br>(ON: Forward run OFF: Stop)  | <ul style="list-style-type: none"> <li>Photocoupler</li> <li>24 V, 6 mA</li> </ul> <p><b>Note:</b><br/>Install the wire jumpers between terminals SC-SP and SC-SN to set the MFDI power supply (sinking/sourcing mode or internal/external power supply).</p> <ul style="list-style-type: none"> <li>Sinking Mode: Install a jumper between terminals SC and SP.</li> </ul> <p><b>NOTICE: Do not close the circuit between terminals SC and SN. A closed circuit between these terminals will cause damage to the drive.</b></p> <ul style="list-style-type: none"> <li>Sourcing Mode: Install a jumper between terminals SC and SN.</li> </ul> <p><b>NOTICE: Do not close the circuit between terminals SC and SP. A closed circuit between these terminals will cause damage to the drive.</b></p> <ul style="list-style-type: none"> <li>External power supply: No jumper necessary between terminals SC-SN and terminals SC-SP.</li> </ul> |
|                            | S2                        | MFDI selection 2<br>(ON: Reverse run OFF: Stop)  |  |
|                            | S3                        | MFDI selection 3<br>(External fault (N.O.))  |  |
|                            | S4                        | MFDI selection 4<br>(Fault reset)  |  |
|                            | S5                        | MFDI selection 5<br>(Multi-step speed reference 1)   |  |
|                            | S6                        | MFDI selection 6<br>(Multi-step speed reference 2)   |  |
|                            | S7                        | MFDI selection 7<br>(Jog command)  |  |
|                            | S8                        | MFDI selection 8<br>(Baseblock command (N.O.))   |  |
|                            | SN                        | MFDI power supply 0 V  |  |
|                            | SC                        | MFDI selection common  |  |
| SP                         | MFDI power supply +24 Vdc | MFDI power supply, 24 V (maximum 150 mA)<br><b>NOTICE: Do not close the circuit between terminals SP and SN. Failure to obey will cause damage to the drive.</b> |  |
| Safe Disable Input         | H1                        | Safe Disable input 1   | Remove the jumper between terminals H1-HC and H2-HC to use the Safe Disable input. <ul style="list-style-type: none"> <li>24 V, 6 mA</li> <li>ON: Normal operation</li> <li>OFF: Coasting motor</li> <li>Internal impedance 4.7 kΩ</li> <li>OFF Minimum OFF time of 2 ms.</li> </ul>   |
|                            | H2                        | Safe Disable input 2   |  |
|                            | HC                        | Safe Disable function common   |  |
| Master Frequency Reference | RP                        | Master frequency reference pulse train input<br>(Master frequency reference)   | <ul style="list-style-type: none"> <li>Response frequency: 0 Hz to 32 kHz</li> <li>H level duty: 30% to 70%</li> <li>H level voltage: 3.5 V to 13.2 V</li> <li>L level voltage: 0.0 V to 0.8 V</li> <li>Input impedance: 3 kΩ</li> </ul>   |
|                            | +V                        | Power supply for frequency setting   | 10.5 V (allowable current 20 mA maximum)   |
|                            | -V                        | Power supply for frequency setting   | -10.5 V (allowable current 20 mA maximum)  |
|                            | A1                        | MFAI1<br>(Master frequency reference)  | Voltage input or current input<br>Select terminal A1 with DIP switch S1-1 and H3-01 [Terminal A1 Signal Level Select].<br>Select terminal A2 with DIP switch S1-2 and H3-09 [Terminal A2 Signal Level Select]  |
|                            | A2                        | MFAI2<br>(Combined to terminal A1)   | <ul style="list-style-type: none"> <li>-10 V to +10 V/-100% to +100% (input impedance: 20 kΩ)</li> <li>0 V to 10 V/100% (input impedance: 20 kΩ)</li> <li>4 mA to 20 mA/100%, 0 mA to 20 mA/100% (input impedance: 250 Ω)</li> </ul>   |
|                            | A3                        | MFAI3/PTC input<br>(Auxiliary frequency reference)   | <ul style="list-style-type: none"> <li>Voltage input or current input<br/>Select using DIP switch S1-3 and H3-05 [Terminal A3 Signal Level Select].</li> <li>-10 V to +10 V/-100% to +100% (input impedance: 20 kΩ)</li> <li>0 V to 10 V/100% (input impedance: 20 kΩ)</li> <li>4 mA to 20 mA/100%, 0 mA to 20 mA/100% (input impedance: 250 Ω)</li> <li>PTC input (Motor Overheat Protection)<br/>Set DIP switch S4 to "PTC" and set DIP switch S1-3 to "V" to set terminal A3 for PTC input.</li> </ul>  |
|                            | AC                        | Frequency reference common   | 0 V  |
| E (G)                      | Connecting shielded cable | -  |  |

## ■ Output Terminals

Refer to Table 4.4 and Table 4.5 for a list of output terminals and functions.

## 4.5 Control Circuit Wiring

**Table 4.4 Control Circuit Output Terminals**

| Type               | Terminal | Name (Default)        | Function (Signal Level)   |
|--------------------|----------|-----------------------|---|
| Fault Relay Output | MA       | N.O. output (Fault)   | <ul style="list-style-type: none"> <li>Relay output</li> <li>30 Vdc, 10 mA to 1 A</li> <li>250 Vac, 10 mA to 1 A</li> <li>Minimum load: 5 V, 10 mA (Reference value)</li> </ul>   |
|                    | MB       | N.C. output (Fault)   |   |
|                    | MC       | Digital output common |   |
| MFDO               | M1       | MFDO (During run)     | <ul style="list-style-type: none"> <li>Relay output</li> <li>30 Vdc, 10 mA to 1 A</li> <li>250 Vac, 10 mA to 1 A</li> <li>Minimum load: 5 V, 10 mA (Reference value)</li> </ul> <p><b>Note:</b><br/>Do not set functions that frequently switch ON/OFF to MFDO (M1 to M6) because this will decrease the performance life of the relay contacts. Yaskawa estimates switching life at 200,000 times (assumes 1 A, resistive load).</p> |
|                    | M2       |                       |   |
|                    | M3       | MFDO (Zero speed)     |   |
|                    | M4       |                       |   |
|                    | M5       | MFDO (Speed agree 1)  |   |
|                    | M6       |                       |   |

**Table 4.5 Control Circuit Monitor Output Terminals**

| Type           | Terminal | Name (Default)                             | Function (Signal Level)  |
|----------------|----------|--|--|
| Monitor Output | MP       | Pulse train output (Output frequency)      | 32 kHz (maximum)<br>Refer to "Pulse Train Output" on page 642 for more information.  |
|                | FM       | Analog monitor output 1 (Output frequency) | Select voltage or current output. <ul style="list-style-type: none"> <li>0 V to 10 V/0% to 100%</li> <li>-10 V to +10 V/-100% to +100%</li> <li>4 mA to 20 mA (receiver recommended impedance: 250 Ω)</li> </ul> |
|                | AM       | Analog monitor output 2 (Output current)   | <p><b>Note:</b><br/>Select with jumper switch S5 and H4-07 [Terminal FM Signal Level Select] or H4-08 [Terminal AM Signal Level Select].</p>   |
|                | AC       | Monitor common                             | 0 V  |

### ■ External Power Supply Input Terminals

Refer to Table 4.6 for a list of the functions of the external power supply input terminals.

**Table 4.6 External Power Supply Input Terminals**

| Type                                  | Terminal | Name (Default)                    | Function  |
|---------------------------------------|----------|-----------------------------------|---|
| External Power Supply Input Terminals | PS       | External 24 V power supply input  | Supplies backup power to the drive control circuit, keypad, and option board.<br>21.6 VDC to 26.4 VDC, 700 mA |
|                                       | AC       | External 24 V power supply ground | 0 V   |

### ■ Serial Communication Terminals

Refer to Table 4.7 for a list of serial communication terminals and functions.

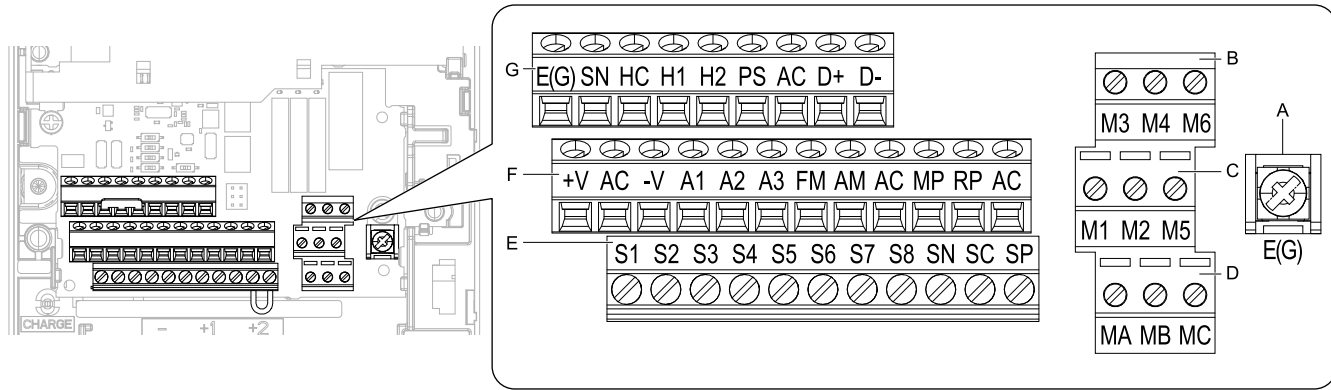
**Table 4.7 Serial Communication Terminals**

| Type                 | Terminal | Terminal Name                  | Function (Signal Level)  |
|----------------------|----------|--------------------------------|--|
| Modbus Communication | D+       | Communication input/output (+) | MEMOBUS/Modbus communications<br>Use an RS-485 cable to connect the drive. <p><b>Note:</b><br/>Set DIP switch S2 to ON to enable the termination resistor in the last drive in a MEMOBUS/Modbus network.</p> <ul style="list-style-type: none"> <li>RS-485</li> <li>MEMOBUS/Modbus communication protocol</li> <li>Maximum 115.2 kbps</li> </ul> |
|                      | D-       | Communication output (-)       |  |
|                      | AC       | Signal ground                  | 0 V  |

### ◆ Control Circuit Terminal Configuration

The control circuit terminals are in the positions shown in Figure 4.17.





- A - Terminal block (TB5)
- B - Terminal block (TB2-3)
- C - Terminal block (TB2-2)
- D - Terminal block (TB2-1)
- E - Terminal block (TB1)
- F - Terminal block (TB3)
- G - Terminal block (TB4)

Figure 4.17 Control Circuit Terminal Arrangement

The tightening torque for the terminal screws is shown on the reverse side or the lower front side of the front cover.

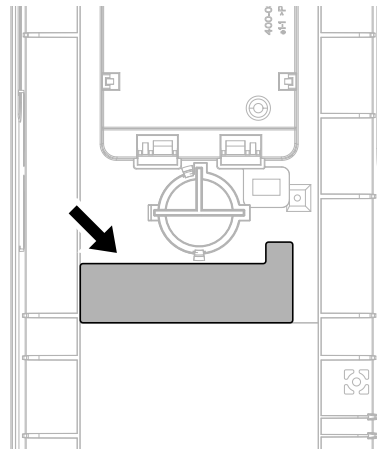


Figure 4.18 Tightening Torque Display Location (Reverse side of Front Cover)

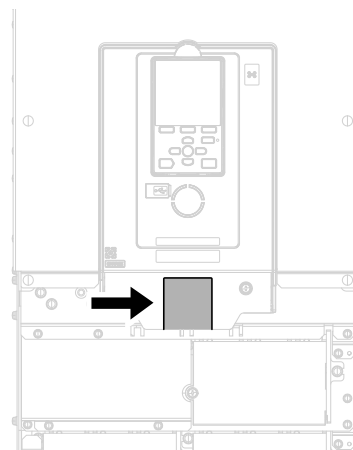


Figure 4.19 Tightening Torque Display Location (Lower Front Side of Front Cover)

### ■ Control Circuit Wire Gauges and Tightening Torques

Use the tables in this section to select the correct wires. Use shielded wire to wire the control circuit terminal block. Use crimp ferrules on the wire ends to make the wiring procedure easier and more reliable.

## 4.5 Control Circuit Wiring

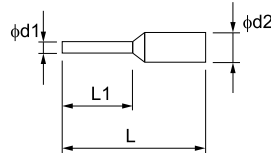
**Table 4.8 Control Circuit Wire Gauges and Tightening Torques**

| Terminal Block | Terminal  | Screw Size | Tightening Torque<br>N·m (in·lb) | Bare Wire                                  |   | Crimp Ferrule                              |   |
|----------------|---|------------|----------------------------------|--|---|--|---|
|                |   |            |                                  | Recommended Gauge<br>mm <sup>2</sup> (AWG) | Applicable Gauge<br>mm <sup>2</sup> (AWG)   | Recommended Gauge<br>mm <sup>2</sup> (AWG) | Applicable Gauge<br>mm <sup>2</sup> (AWG) |
| TB1            | S1 - S8, SN, SC, SP                               | M3         | 0.5 - 0.6<br>(4.4 - 5.3)         | 0.75<br>(18)                               | <ul style="list-style-type: none"> <li>Stranded wire<br/>0.2 - 1.0<br/>(24 - 16)</li> <li>Solid wire<br/>0.2 - 1.5<br/>(24 - 16)</li> </ul> | 0.5<br>(20)                                | 0.25 - 0.5<br>(24 - 20)                   |
| TB2            | M1 - M6, MA, MB, MC                               |            |                                  |  |   |  |   |
| TB3            | +V, AC, -V, A1, A2, A3, FM, AM,<br>AC, MP, RP, AC |            |                                  |  |   |  |   |
| TB4            | E (G), SN, HC, H1, H2, PS, AC, D+,<br>D-          |            |                                  |  |   |  |   |
| TB5            | E (G)   | M3.5       | 0.5 - 1.0<br>(4.4 - 8.9)         | 0.5 - 2<br>(20 - 14)                       | 1.25<br>(12)  | -  | -   |

### Crimp Ferrules

Attach an insulated sleeve when you use crimp ferrules. Refer to Table 4.9 for the recommended external dimensions and model numbers of the crimp ferrules.

Use the CRIMPFOX 6, a crimping tool made by PHOENIX CONTACT.



**Figure 4.20 External Dimensions of Crimp Ferrules**

**Table 4.9 Crimp Ferrule Models and Sizes**

| Wire Gauge<br>mm <sup>2</sup> (AWG) | Model                     | L (mm) | L1 (mm) | φd1 (mm) | φd2 (mm) |
|-------------------------------------|---------------------------|--------|---------|----------|----------|
| 0.25 (24)                           | AI 0.25-8YE               | 12.5   | 8       | 0.8      | 2.0      |
| 0.34 (22)                           | AI 0.34-8TQ               | 12.5   | 8       | 0.8      | 2.0      |
| 0.5 (20)                            | AI 0.5-8WH,<br>AI 0.5-8OG | 14     | 8       | 1.1      | 2.5      |

## ◆ Wiring the Control Circuit Terminal

**WARNING!** *Electrical Shock Hazard. Do not remove covers or touch circuit boards while the drive is energized. If you touch the internal components of an energized drive, it can cause serious injury or death.*

**NOTICE:** *Do not let wire shields touch other signal lines or equipment. Insulate the wire shields with electrical tape or shrink tubing. If you do not insulate the wire shields, it can cause a short circuit and damage the drive.*

### Note:

- Isolate control circuit wiring from main circuit wiring (terminals R/L1, S/L2, T/L3, B1, B2, U/T1, V/T2, W/T3, -, +1, +2) and other high-power wiring. If the control circuit wires are adjacent to the main circuit wires, the drive or the devices around the drive may malfunction due to electrical interference.
- Isolate contact output terminals MA, MB, MC and M1-M6 from other control circuit wiring. If the output terminal wires are adjacent to other control circuit wires, the drive or devices around it may malfunction due to electrical interference.
- Connect the control circuit to a power supply of Class 2 (UL standard). Improper application of peripheral devices could result in drive performance degradation due to improper power supply.
- Connect the shield of shielded cable to the applicable ground terminal. If the grounding is not correct, the drive or devices around it may malfunction due to electrical interference.

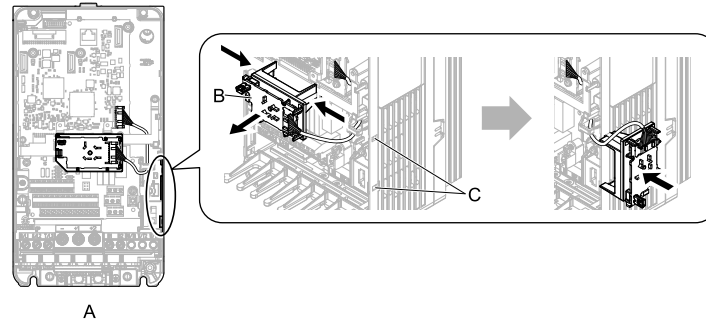
Correctly ground the drive terminals and complete main circuit wiring before you wire the control circuit. Remove the keypad and front cover.

1. Push in on the tabs on the both sides of the LED status ring board to release the board from the bracket. Pull the board forward to remove it.

**NOTICE:** *When you remove the LED Status Board from the drive bracket, make sure that you temporarily install it in the holding position provided on the drive. If you cause damage to the LED status ring board, the LEDs will not function correctly.*

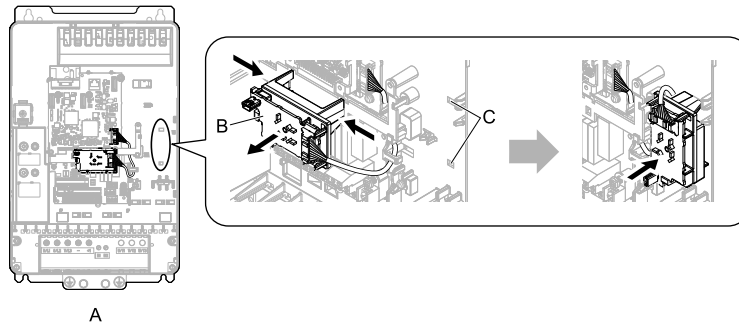
**Note:**

You can temporarily store the LED status ring board with the temporary placement holes on the drive. The location of the temporary placement holes is different on different drive models.



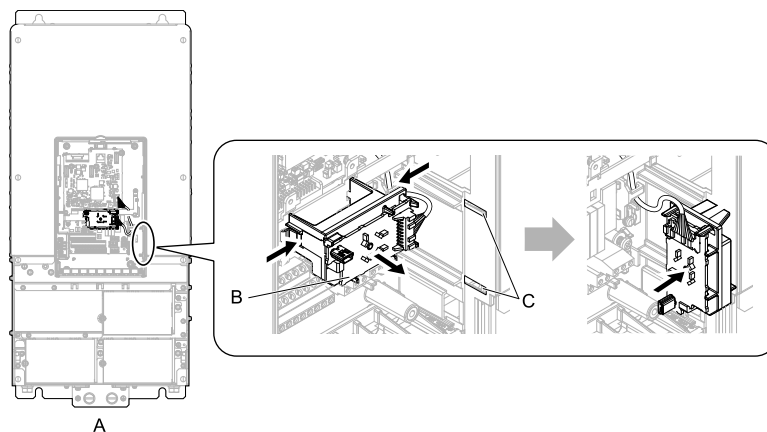
A - Drive front  
 B - LED status ring board  
 C - Temporary placement holes

**Figure 4.21 Remove the LED Status Ring Board**



A - Drive front  
 B - LED status ring board  
 C - Temporary placement holes

**Figure 4.22 Remove the LED Status Ring Board**



A - Drive front  
 B - LED status ring board  
 C - Temporary placement holes

**Figure 4.23 Remove the LED Status Ring Board**

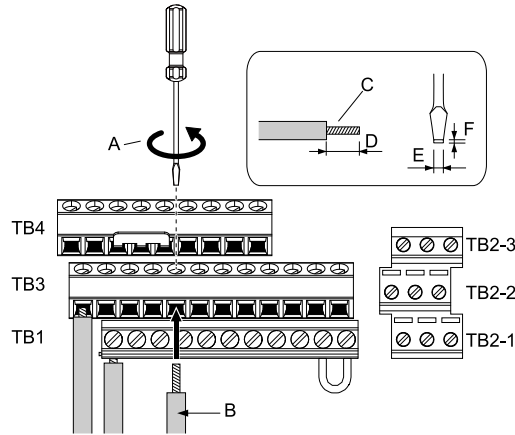
2. Refer to the following figure and wire the control circuit.

**WARNING! Fire Hazard.** Tighten all terminal screws to the correct tightening torque. Connections that are too loose or too tight can cause incorrect operation and damage to the drive. Incorrect connections can also cause death or serious injury from fire.

## 4.5 Control Circuit Wiring

**Note:**

- To prevent malfunction due to electrical interference, use shielded wires and shielded twisted-pair wires for the control circuit terminal wiring. If the grounding is not correct, the drive or devices around it may malfunction due to electrical interference.
- Do not use control circuit wiring that is longer than 50 m (164 ft) to supply the frequency reference with an analog signal from a remote source. Failure to observe this could cause unsatisfactory system performance.

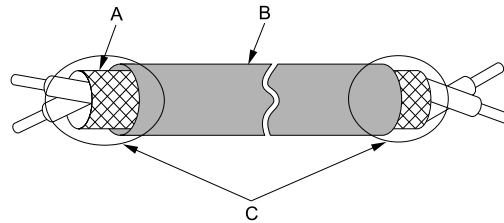


- A - Loosen the screws and put the wire into the opening on the terminal block.**
- B - Wire with a crimp ferrule attached, or unsoldered wire with the core wires lightly twisted**
- C - Pull back the shielding and lightly twist the end with your fingers to keep the ends from fraying.**
- D - Remove approximately 5.5 mm (0.21 in) of the covering at the end of the wire if you do not use crimp ferrules.**
- E - Blade width of 2.5 mm (0.1 in) or less**
- F - Blade depth of 0.4 mm (0.01 in) or less**

**Figure 4.24 Wiring Procedure for the Control Circuit**

**Note:**

- Do not solder the core wire. Soldered wire connections can become loose over time and cause unsatisfactory drive performance.
- Tighten all terminal screws to the correct tightening torque. Connections that are too loose or too tight can cause incorrect operation and damage to the drive. Incorrect connections can also cause death or serious injury from fire.
- Refer to Figure 4.25 for information to prepare terminal ends of the shielded wire.
- Prepare the wire ends of shielded twisted-pair wires as shown in Figure 4.25 to use an analog reference from an external frequency setting potentiometer to set the frequency. Connect the shield to terminal E (G) of the drive.



- A - Connect the shield to terminal E (G) of the drive.**
- B - Sheath**
- C - Insulate with electrical tape or shrink tubing.**

**Figure 4.25 Prepare the Ends of Shielded Wire**

3. Put the cable through the clearance in the wiring cover.

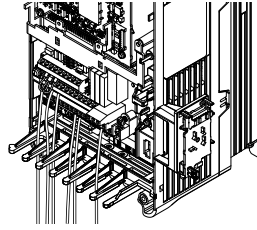


Figure 4.26 Control Circuit Wiring

4. Install the LED status ring board, front cover, and the keypad to their initial positions.

### ◆ Switches and Jumpers on the Terminal Board

The terminal board has switches to adapt the drive I/Os to the external control signals as shown in Figure 4.27. Set the switches to select the functions for each terminal.

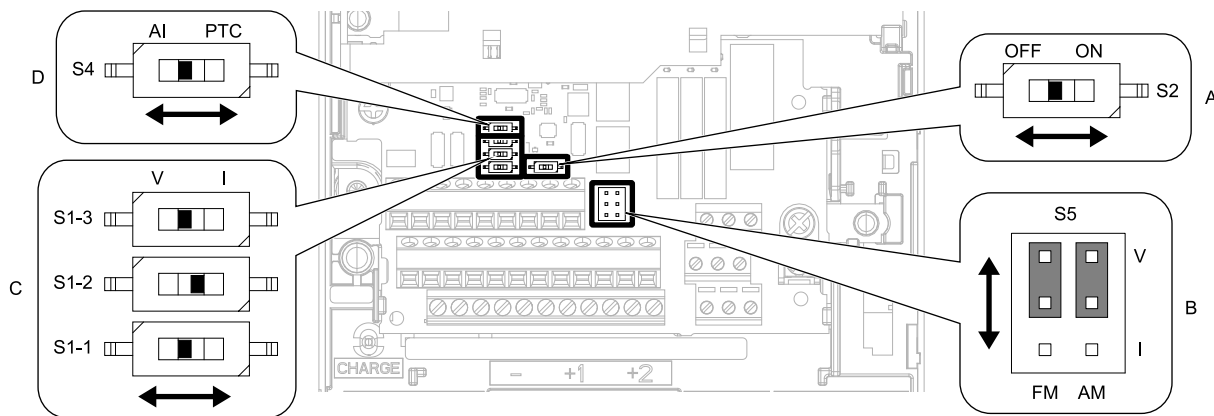


Figure 4.27 Locations of Switches

Table 4.10 I/O Terminals and Switches Functions

| Position | Switch           | Terminal | Function   | Default Setting                                  |
|----------|------------------|----------|--|--|
| A        | DIP switch S2    | -        | Enables and disables the MEMOBUS/Modbus communications termination resistor. | OFF  |
| B        | Jumper switch S5 | FM, AM   | Sets terminals FM and AM to voltage or current output.                       | FM: V (voltage output)<br>AM: V (voltage output) |
| C        | DIP switch S1-1  | A1       | Selects the input signal type (voltage/current).                             | V (voltage input)                                |
|          | DIP switch S1-2  | A2       | Selects the input signal type (voltage/current).                             | I (current input)                                |
|          | DIP switch S1-3  | A3       | Selects the input signal type (voltage/current).                             | V (voltage input)                                |
| D        | Dip switch S4    | A3       | Selects MFAI or PTC input.   | AI (analog input)                                |

## 4.6 Control I/O Connections

This section gives information about the settings for the listed control circuit I/O signals.

- MFDI (terminals S1 to S8)
- Pulse train output (terminal MP)
- MFAI (terminals A1 to A3)
- PTC input (terminal A3)
- MFAO (terminals FM, AM)
- MEMOBUS/Modbus communications (terminals D+, D-, AC)

### ◆ Pulse Train Output

You can use pulse train monitor output terminal MP for sourcing mode or for sinking mode.

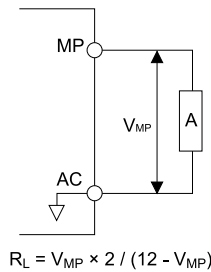
**NOTICE:** Connect peripheral devices correctly. Failure to obey can cause incorrect drive operation and damage to the drive or connected circuits.

- Use for sourcing mode  
The load impedance changes the voltage level of the pulse train output signal.

| Load Impedance<br>$R_L(k\Omega)$ | Output Voltage<br>$V_{MP}(V)$ |
|----------------------------------|-------------------------------|
| 1.5 k $\Omega$ or more           | 5 V or more                   |
| 4.0 k $\Omega$ or more           | 8 V or more                   |
| 10 k $\Omega$ or more            | 10 V or more                  |

**Note:**

Use the formula in Figure 4.28 to calculate the necessary load resistance (k $\Omega$ ) to increase output voltage  $V_{MP}(V)$ .

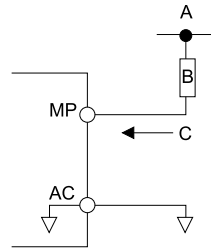


**A - Load Impedance**

**Figure 4.28 Wiring to Use Pulse Train Output in Sourcing Mode**

- Use in sinking mode  
The external power supply changes the voltage level of the pulse train output signal. Keep the voltage from an external source between 10.8 Vdc to 16.5 Vdc. Adjust the load impedance to keep the current at 16 mA or lower.

| External Power Supply (V) | Load Impedance (k $\Omega$ ) | Sinking current (mA) |
|---------------------------|------------------------------|----------------------|
| 10.8 Vdc to 16.5 Vdc      | 1.0 k $\Omega$ or more       | 16 mA maximum        |



**A - External power supply**                      **C - Sinking current**  
**B - Load Impedance**

Figure 4.29 Wiring to Use Pulse Train Output in Sinking Mode

◆ **Set Sinking Mode/Sourcing Mode**

Close the circuit between terminals SC-SP and SC-SN to set the sinking mode/sourcing mode and the internal/external power supply for the MFDI terminals. The default setting for the drive is internal power supply sinking mode.

**NOTICE:** Do not close the circuit between terminals SP and SN. Failure to obey will cause damage to the drive.

| Mode                | Internal Power Supply (Terminal SN-SP) | External 24 V power supply |
|---------------------|--|----------------------------|
| Sinking Mode (NPN)  |  |                            |
| Sourcing Mode (PNP) |  |                            |

◆ **Set Input Signals for MFAI Terminals A1 to A3**

Use terminals A1 to A3 to input a voltage or a current signal. Set the signal type as shown in Table 4.11.

## 4.6 Control I/O Connections

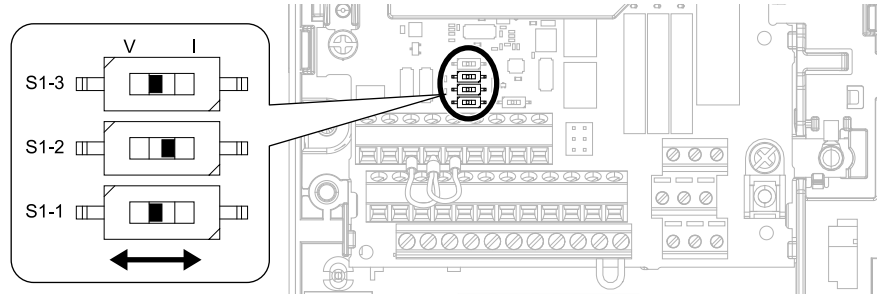


Figure 4.30 Location of DIP Switch S1

Table 4.11 MFAI Terminals A1 to A3 Signal Settings

| Terminal | Input Signal  | DIP Switch Settings |                | Parameter |  |
|----------|---------------|---------------------|----------------|-----------|--|
|          |               | Switch              | Setting        | No.       | Signal Level   |
| A1       | Voltage input | S1-1                | V<br>(Default) | H3-01     | 0: 0 V to 10 V/0% to 100% (input impedance: 20 kΩ)<br>1: -10 V to +10 V/-100% to 100% (input impedance: 20 kΩ) |
|          | Current input |                     | I              |           | 2: 4 mA to 20 mA/0% to 100% (input impedance: 250 Ω)<br>3: 0 mA to 20 mA/0% to 100% (input impedance: 250 Ω)   |
| A2       | Voltage input | S1-2                | V              | H3-09     | 0: 0 V to 10 V/0% to 100% (input impedance: 20 kΩ)<br>1: -10 V to +10 V/-100% to 100% (input impedance: 20 kΩ) |
|          | Current input |                     | I<br>(Default) |           | 2: 4 mA to 20 mA/0% to 100% (input impedance: 250 Ω)<br>3: 0 mA to 20 mA/0% to 100% (input impedance: 250 Ω)   |
| A3       | Voltage input | S1-3                | V<br>(Default) | H3-05     | 0: 0 V to 10 V/0% to 100% (input impedance: 20 kΩ)<br>1: -10 V to +10 V/-100% to 100% (input impedance: 20 kΩ) |
|          | Current input |                     | I              |           | 2: 4 mA to 20 mA/0% to 100% (input impedance: 250 Ω)<br>3: 0 mA to 20 mA/0% to 100% (input impedance: 250 Ω)   |

**Note:**

- Set H3-02, H3-10 = 0 [Terminal A1 Function Selection, Terminal A2 Function Selection = Frequency Reference] to set A1 and A2 to frequency reference. The drive will add the analog input values together to make the frequency reference.
- Use tweezers or a jig with a tip width of approximately 0.8 mm (0.03 in) to set DIP switches.
- Set DIP switch S4 to "AI" to use terminal A3 as an analog input (voltage/current) terminal. The default setting for DIP switch S4 is "AI".

### ◆ Set MFAI Terminal A3 to PTC Input

Set terminal A3 as an MFAI or as the PTC input for motor overload protection.  
Use DIP switch S4 to set the input function.

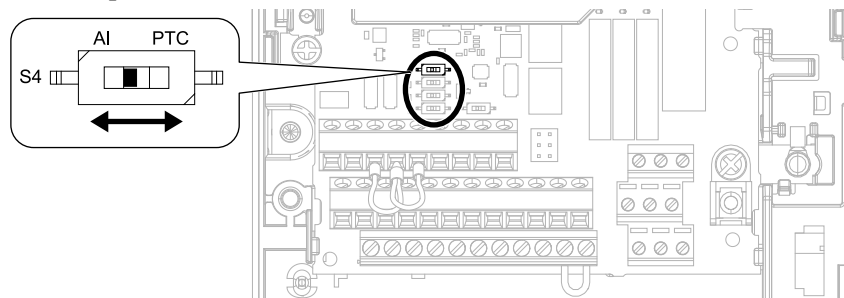


Figure 4.31 Location of DIP Switch S4

| Terminal | Settings for DIP Switches | Description  |
|----------|---------------------------|--|
| A3       | AI<br>(Default)           | Functions as an MFAI terminal.<br>Set H3-06 [Terminal A3 Function Selection] to select the input function.                   |
|          | PTC                       | Functions as the PTC input terminal.<br>Set H3-06 = E [Motor Temperature (PTC Input)].<br>Set S1-3 to "V" for voltage input. |



◆ **Set Output Signals for MFAO Terminals FM, AM**

Set the signal type for terminals AM and FM to voltage or current output. Use jumper switch S5 and H4-07, H4-08 [Terminal FM Signal Level Select, Terminal AM Signal Level Select] to set the signal type.

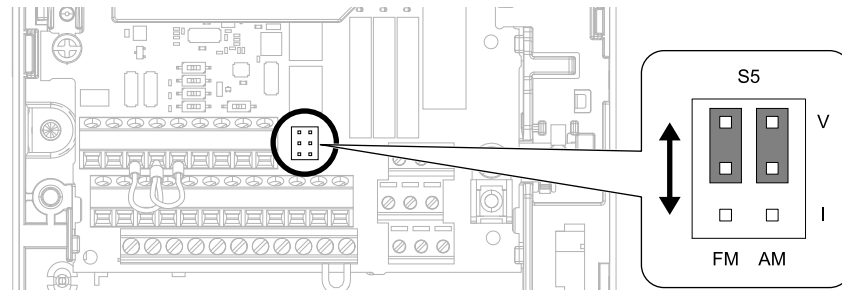


Figure 4.32 Location of Jumper Switch S5

| Terminal | Types of Output Signals  | Jumper Switch S5 | Parameter |                                     |
|----------|--------------------------|------------------|-----------|-------------------------------------|
|          |                          |                  | No.       | Signal Level                        |
| FM       | Voltage output (Default) |                  | H4-07     | 0: 0 V to 10 V<br>1: -10 V to +10 V |
|          | Current output           |                  |           | 2: 4 mA to 20 mA                    |
| AM       | Voltage output (Default) |                  | H4-08     | 0: 0 V to 10 V<br>1: -10 V to +10 V |
|          | Current output           |                  |           | 2: 4 mA to 20 mA                    |

◆ **Switch ON Termination Resistor for MEMOBUS/Modbus Communications**

When the drive is the last slave in a MEMOBUS/Modbus communications, set DIP switch S2 to the ON position. This drive has a built-in termination resistor for the RS-485 interface.

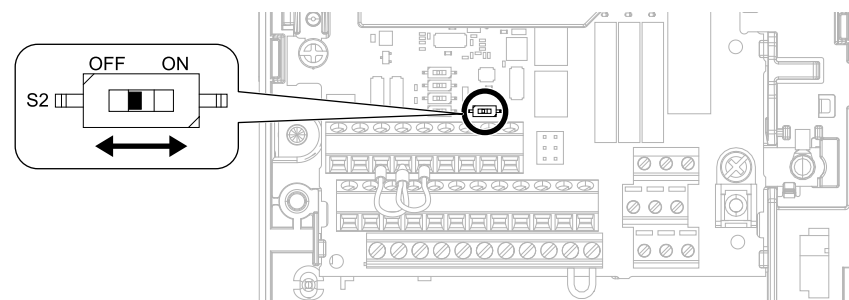


Figure 4.33 Location of DIP Switch S2

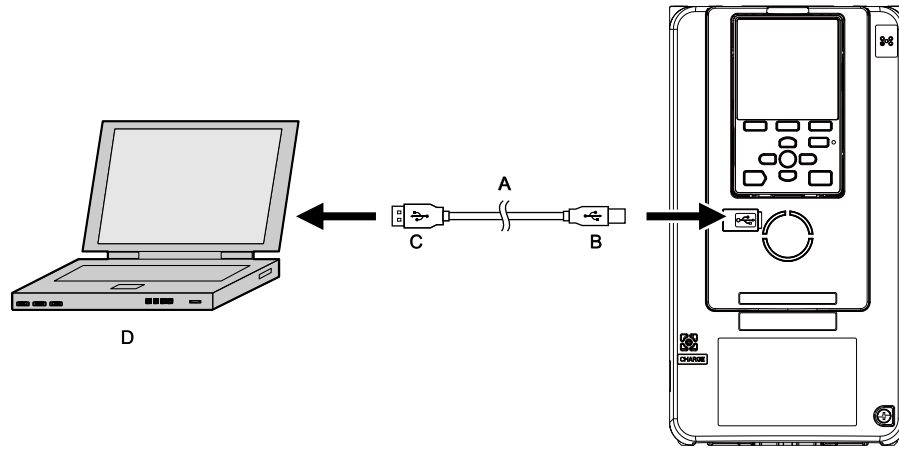
Table 4.12 MEMOBUS/Modbus Communications Termination Resistor Setting

| DIP Switch S2 | Description                               |
|---------------|---|
| ON            | The built-in termination resistor is ON.  |
| OFF (Default) | The built-in termination resistor is OFF. |

## 4.7 Connect the Drive to a PC

The drive has a mini-B type USB port.

You can use a USB cable (USB 2.0, type: A - mini-B) to connect the drive to a type-A USB port on a PC. After you connect the drive to the PC, you can use Yaskawa DriveWizard Industrial software to monitor drive performance and manage parameter settings.



- A - USB 2.0, type A - mini-B cable
- B - Mini-B type connector
- C - Type-A connector
- D - PC

Figure 4.34 Connect to a PC (USB)

Yaskawa recommends using a USB cable with connectors connected via shielded wires.

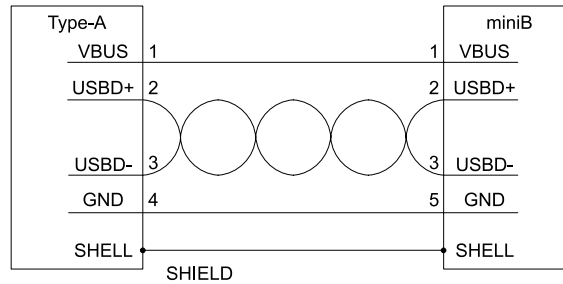


Figure 4.35 Recommended USB Cable

# Index

## Numerics

- 24 V power supply
  - Power supply input terminals ..... 636

## A

- Acceleration and deceleration times
  - Switching by external input ..... 257
  - Switching by output frequency ..... 258
  - Switching by Motor 2 Selection commands ..... 258
- Acceleration time
  - Parameter ..... 257
  - Unit of measurement setting ..... 260
- Adjustment of control functionality ..... 608
- AFR
  - Parameter ..... 494
- ALM indicator ..... 551, 554
- ALM/ERR
  - LED status ..... 557
- Ambient Temperature Setting
  - Parameter ..... 486
- Analog gauge
  - Monitors ..... 565
- Analog input
  - Function selection for terminals A1 through A3 ..... 415
- Analog Output
  - Gain/Bias Adjustment ..... 428
  - Monitor Parameter Selection ..... 428
  - Signal Level Selection ..... 428
  - Terminal AM Monitor Selection ..... 430
  - Terminal FM Monitor Selection ..... 429
- Application Preset ..... 189
- ASR
  - Closed Loop V/f Control adjustment procedure ..... 271
  - Fine tuning ..... 273
  - Parameter ..... 270
  - Vector Control Adjustment Procedure ..... 271
- ASR tuning ..... 601
  - Precautions ..... 605
- Auto-Tuning ..... 597
  - ASR and Inertia Tuning Parameters ..... 546
  - ASR tuning ..... 601
  - Induction Motor ..... 597
  - Induction Motor Parameters ..... 540
  - Inertia Tuning ..... 601
  - PM Motor Parameters ..... 543
  - PM Motors ..... 598
  - Precautions ..... 603
  - Precautions to Note before ASR Tuning ..... 605
  - Precautions to Note before Inertia Tuning ..... 605
  - Procedure ..... 582
  - Rotational Auto-Tuning Precautions ..... 604
  - Stationary Auto-Tuning for Line-to-Line Resistance
    - precautions ..... 605
  - Stationary Auto-Tuning Precautions ..... 604
  - Stator resistance Auto-Tuning precautions ..... 605

## B

- Backlight
  - Timing of shut-off ..... 593
- Backup

- Parameters (drive to keypad) ..... 574
- Backup function ..... 530
- Bar graph
  - Monitors ..... 563
- Base frequency
  - Parameter ..... 312
- Base Frequency
  - Motor 2 Parameters ..... 317
- Base voltage
  - Motor 2 parameters ..... 318
  - Parameter ..... 313
- Bi-Directional function ..... 297
- Braking Resistor
  - Protective function ..... 483
- bUS
  - Detection condition settings ..... 355
  - Detection conditions ..... 351
  - Operation Selection after Detection ..... 350

## C

- Capacitor Maintenance Setting ..... 532
- Carrier frequency
  - Diminish ..... 488
  - Parameter ..... 279
- CE
  - Detection Selection ..... 433
  - Detection Time ..... 433
  - Operation Selection after Detection ..... 432
- Checklist
  - Test run ..... 615
- Communication option
  - Parameter ..... 345
- Connecting multiple drives ..... 346
- Control circuit terminals
  - Configuration of terminal block ..... 636
  - I/O terminals function selection switches ..... 641
  - Terminal functions ..... 634
  - Wire gauge ..... 637
  - Wiring ..... 633
  - Wiring procedure for terminal block ..... 638
- Control method
  - Selection ..... 186
- Cooling Fan
  - Activation Conditions Setting ..... 485
  - Off Delay Timer ..... 486
- CoolingFan OperationTime Setting ..... 532
- Crimp ferrule ..... 637
- Cumulative Operation Time Select ..... 532
- Cumulative Operation TimeSetting ..... 532
- Current Detection Speed Search ..... 221

## D

- Data log ..... 591
  - Monitor selection ..... 591
  - Sampling time ..... 592
  - Start procedure ..... 590
  - Stop procedure ..... 590
- DC Injection Braking
  - Parameter ..... 217
- DCBusPreChargeRelayMainteSetting ..... 533
- Deceleration time
  - Parameter ..... 257
  - Unit of measurement setting ..... 260
- Delete

|   |          |   |               |
|---|----------|---|---------------|
| Delete Backed-up Parameters.....              | 577      | Parameter .....                         | 471           |
| Derating                                      |          | Feed Forward Control                    |               |
| Ambient Temperature Setting.....              | 486      | Parameter .....                         | 502           |
| Enclosure Type .....                          | 488      | Field Forcing                           |               |
| External Cooling Fin.....                     | 488      | Parameter .....                         | 302           |
| Finless.....                                  | 488      | Field weakening                         |               |
| Side-by-side .....                            | 488      | Parameter .....                         | 302           |
| dEv   |          | Fine tuning .....                       | 608           |
| Detection level.....                          | 329      | Finless                                 |               |
| Detection time .....                          | 329      | Derating.....                           | 488           |
| Operation Selection after Detection.....      | 328      | Firmware update lock.....               | 202           |
| DI-A3   |          | Freq Ref Setting Method Select.....     | 528           |
| Parameter .....                               | 335      | Freq reference bias                     |               |
| Digital input option                          |          | Parameter .....                         | 297           |
| Parameter .....                               | 335      | Frequency Agreement                     |               |
| Digital output option                         |          | Parameter .....                         | 470           |
| Parameter .....                               | 342      | Frequency reference                     |               |
| DIP switch .....                              | 641      | Command source correlation diagram..... | 284           |
| DO-A3   |          | LOCAL/REMOTE Run selection.....         | 204, 284      |
| Parameter .....                               | 342      | Offset frequency addition .....         | 303           |
| Down 2 command                                |          | Switching between LOCAL/REMOTE .....    | 204, 213, 284 |
| Parameter .....                               | 292, 297 | Upper and lower frequency limits.....   | 290           |
| Down command .....                            | 375–376  | Frequency Reference                     |               |
| Parameter .....                               | 292, 297 | Making changes using keypad.....        | 559           |
| Drive   |          | Frequency reference bias                |               |
| Initialization.....                           | 187      | Parameter .....                         | 292           |
| Initialize Parameters .....                   | 187      | Frequency reference hold function       |               |
| Drive Mode Unit Monitor Select.....           | 519      | Parameter .....                         | 292, 297      |
| Drive Model Selection.....                    | 527      | <b>G</b>                                |               |
| Droop Control                                 |          | Gateway mode.....                       | 346           |
| Parameter .....                               | 249      | GF                                      |               |
| dv3   |          | Protective function .....               | 485           |
| Detection condition settings.....             | 330      | Ground Fault Detection                  |               |
| dv4   |          | Protective function .....               | 485           |
| Detection condition settings.....             | 330      | <b>H</b>                                |               |
| Dwell function                                |          | HCA                                     |               |
| Parameter .....                               | 248      | Alarm Settings .....                    | 489           |
| <b>E</b>                                      |          | High-Slip Braking                       |               |
| E5  |          | Parameter .....                         | 495           |
| Operation Selection after Detection.....      | 354      | HOME screen.....                        | 559           |
| EF0   |          | Horsepower .....                        | 525           |
| Detection conditions .....                    | 351      | <b>I</b>                                |               |
| Detection conditions setting (DeviceNet)..... | 358      | IGBT Maintenance Setting .....          | 533           |
| Operation Selection after Detection.....      | 351      | Induction Motor                         |               |
| Enclosure Type                                |          | Auto-Tuning.....                        | 597           |
| Derating.....                                 | 488      | Inertia Tuning.....                     | 601           |
| Encoder option                                |          | Precautions .....                       | 605           |
| Parameter .....                               | 326      | Input Phase Detection                   |               |
| Energy-saving control                         |          | Protective function .....               | 484           |
| Parameter .....                               | 250      | Input voltage                           |               |
| ERF type braking resistor                     |          | Parameter .....                         | 306           |
| Protective function .....                     | 483      | Installation                            |               |
| External 24 V power supply                    |          | Front cover .....                       | 622           |
| Power supply input terminals.....             | 636      | Terminal cover .....                    | 622           |
| External Cooling Fin                          |          | Internal Drive Braking Transistor       |               |
| Derating.....                                 | 488      | Protective function .....               | 490           |
| <b>F</b>                                      |          | <b>J</b>                                |               |
| Fast Stop Time                                |          | Jog command .....                       | 290           |
| Parameter .....                               | 260      | Jog operation.....                      | 559           |
| Fault history                                 |          | JOG operation .....                     | 559           |
| Display procedure .....                       | 581      | Jump frequency                          |               |
| Fault Restart                                 |          |   |               |

|   |          |   |         |
|---|----------|---|---------|
| Parameter .....                             | 291      | Parameter .....   | 476     |
| Jumper switch .....                         | 641      | MEMOBUS/Modbus communications                           |         |
| <b>K</b>                                    |          | Setting for termination resistor .....                  | 645     |
| KEB ride-thru function                      |          | MEMOBUS/Modbus Communications                           |         |
| Compensation Time .....                     | 456      | Parameter .....   | 431     |
| Operation during momentary power loss ..... | 455      | Serial communication terminals .....                    | 636     |
| Parameter .....                             | 449      | microSD card  |         |
| KEB Ride-Thru Function                      |          | Insertion slot .....                                    | 551     |
| KEB Method Selection .....                  | 459      | Mid point B frequency                                   |         |
| Single Drive KEB Method .....               | 459      | Motor 2 parameters .....                                | 317     |
| System KEB Method .....                     | 459      | Parameter .....   | 312     |
| Keypad                                      |          | Mid point B voltage                                     |         |
| Backlight setting .....                     | 593      | Motor 2 parameters .....                                | 318     |
| Data log setting .....                      | 591      | Parameter .....   | 313     |
| Display drive information .....             | 594      | Middle Output Frequency                                 |         |
| Display software version .....              | 594      | Motor 2 Parameters .....                                | 317     |
| HOME screen .....                           | 559      | Parameter .....   | 312     |
| Language selection .....                    | 185, 584 | Middle Output Frequency Voltage                         |         |
| Meaning of indicators .....                 | 551      | Motor 2 Parameters .....                                | 317     |
| Method of operation .....                   | 551      | Parameter .....   | 312     |
| Set date and time .....                     | 585      | Minimum output frequency                                |         |
| Set time .....                              | 585      | Parameter .....   | 312     |
| Setup Wizard .....                          | 587      | Minimum Output Frequency                                |         |
| Start/stop data logging .....               | 590      | Motor 2 Parameters .....                                | 317     |
| Keypad Display .....                        | 518      | Induction Motor   |         |
| Keypad Display Selection .....              | 519      | Motor Parameters .....                                  | 313     |
| Keypad Operation .....                      | 526      | Minimum Output Voltage                                  |         |
| Keypad-related settings .....               | 518      | Motor 2 Parameters .....                                | 317     |
| kWh Monitor Initialization .....            | 533      | Parameter .....   | 312     |
| <b>L</b>                                    |          | Momentary Power Loss                                    |         |
| Language selection .....                    | 185      | KEB Compensation Time .....                             | 456     |
| Procedure .....                             | 584      | Monitors  |         |
| LCD contrast adjustment .....               | 521      | Data log setting .....                                  | 591–592 |
| LED Light Function Selection .....          | 529      | Display analog gauge .....                              | 565     |
| LED status ring                             |          | Display bar graph .....                                 | 563     |
| ALM/ERR .....                               | 557      | Display procedure .....                                 | 560     |
| Ready .....                                 | 557      | Set custom monitors .....                               | 561     |
| RUN .....                                   | 557      | Show custom monitors .....                              | 562     |
| LF  |          | Start/stop data logging .....                           | 590     |
| Protective function .....                   | 485      | Trend Plot Display .....                                | 566     |
| LF2   |          | Motor   |         |
| Protection Functions .....                  | 487      | Change direction of motor rotation .....                | 559     |
| Load Inertia Ratio                          |          | Positive Temperature Coefficient (PTC) Thermistor ..... | 443     |
| Parameter .....                             | 468      | Wiring .....  | 631     |
| LO/RE Key Function Selection .....          | 526      | Motor 2   |         |
| LOCAL/REMOTE indicator .....                | 551, 554 | Base Frequency .....                                    | 317     |
| LSo   |          | Base voltage .....                                      | 318     |
| Protective function .....                   | 491      | Control mode settings .....                             | 316     |
| <b>M</b>                                    |          | Leakage Inductance .....                                | 319     |
| Main circuit terminals                      |          | Line-to-Line Resistance .....                           | 319     |
| Wiring .....                                | 631      | Maximum Output Frequency .....                          | 316     |
| Main menu                                   |          | Maximum Output Voltage .....                            | 317     |
| Display procedure .....                     | 559      | Mid point B frequency .....                             | 317     |
| Maintenance Period .....                    | 532      | Mid point B voltage .....                               | 318     |
| Maximum Output Frequency                    |          | Middle Output Frequency .....                           | 317     |
| Motor 2 Parameters .....                    | 316      | Middle Output Frequency Voltage .....                   | 317     |
| Parameter .....                             | 311      | Minimum Output Frequency .....                          | 317     |
| Maximum Output Voltage                      |          | Minimum Output Voltage .....                            | 317     |
| Motor 2 Parameters .....                    | 317      | Motor Iron Loss .....                                   | 320     |
| Parameter .....                             | 312      | Motor Iron-Core Saturation Coefficient 1 .....          | 320     |
| Mechanical Weakening Detection              |          | Motor Iron-Core Saturation Coefficient 2 .....          | 320     |
|   |          | Motor rated power (kW) .....                            | 320     |
|   |          | No-load Current .....                                   | 319     |

|  |          |
|--|----------|
| Number of motor poles .....                            | 319      |
| Rated current .....                                    | 318      |
| Rated Slip .....                                       | 318      |
| V/f Pattern .....                                      | 316      |
| Motor Code Selection .....                             | 321      |
| Motor Overheating                                      |          |
| Operation During Detection of Alarms .....             | 448      |
| Operation During Detection of Faults (PTC Input) ..... | 448      |
| Motor Overload   |          |
| Electric Thermal Protection Operation Time .....       | 447      |
| Protection Functions .....                             | 444      |
| Motor parameters                                       |          |
| Motor 2 .....  | 318      |
| Motor 2 Iron-Core Saturation Coefficient 1 .....       | 320      |
| Motor 2 Iron-Core Saturation Coefficient 2 .....       | 320      |
| Motor 2 No-load Current .....                          | 319      |
| Motor 2 number of motor poles .....                    | 319      |
| Motor 2 rated Current .....                            | 318      |
| Motor 2 rated power (kW) .....                         | 320      |
| Motor Parameters .....                                 | 305, 313 |
| Motor 2 Iron Loss .....                                | 320      |
| Motor 2 Leakage Inductance .....                       | 319      |
| Motor 2 Line-to-Line Resistance .....                  | 319      |
| Motor 2 Rated Slip .....                               | 318      |
| Motor parameters (induction motors) .....              | 313      |
| Leakage Inductance .....                               | 315      |
| Line-to-Line Resistance .....                          | 314      |
| Motor Iron Loss .....                                  | 315      |
| Motor Iron-Core Saturation Coefficient 1 .....         | 315      |
| Motor Iron-Core Saturation Coefficient 2 .....         | 315      |
| Motor rated power (kW) .....                           | 315      |
| No-load Current .....                                  | 314      |
| Number of motor poles .....                            | 314      |
| Rated current .....                                    | 313      |
| Rated Slip .....                                       | 313      |
| Motor Power Unit Selection .....                       | 525      |
| MotorDirect@PowUpWhenUsingKeypad .....                 | 529      |
| Multi-step speed operation .....                       | 284      |
| Setting procedure .....                                | 284      |
| <b>N</b>   |          |
| NumOfRunCommands Counter Initial .....                 | 534      |
| <b>O</b>   |          |
| oC   |          |
| Overcurrent Detection Gain .....                       | 487      |
| Off-Delay Timer .....                                  | 230      |
| Offset frequency                                       |          |
| Parameter .....  | 303      |
| oH   |          |
| Alarm Settings .....                                   | 483      |
| oH2  |          |
| Alarm Settings .....                                   | 483      |
| oH3  |          |
| Operation During Detection of Alarms .....             | 448      |
| oH4  |          |
| Operation During Detection of Faults (PTC Input) ..... | 448      |
| oL2  |          |
| Protective function .....                              | 486      |
| On-Delay Timer .....                                   | 230      |
| Ope Select @Keypad is Disconnect .....                 | 528      |
| Operation During Momentary Power Loss                  |          |
| KEB ride-thru function .....                           | 449      |
| Operation method selection .....                       | 455      |
| Parameter .....  | 455      |
| Speed Search function .....                            | 220      |
| Option card  |          |
| Parameter .....  | 326      |
| oS   |          |
| Detection level .....                                  | 329      |
| Detection time .....                                   | 329      |
| Operation Select at Overspeed .....                    | 327      |
| Output Phase Loss Detection                            |          |
| Protective function .....                              | 485      |
| Overexcitation deceleration                            |          |
| Parameter .....  | 496      |
| Overtorque detection                                   |          |
| Parameter .....  | 474      |
| <b>P</b>   |          |
| Parameter  |          |
| Access Level Selection .....                           | 185      |
| Automatic selection .....                              | 203      |
| Backup (drive to keypad) .....                         | 574      |
| Changing setting values .....                          | 571      |
| Checking modified parameters .....                     | 578      |
| Checking user custom parameters .....                  | 572      |
| Delete Backed-up Parameters .....                      | 577      |
| Restore (Auto Backup) .....                            | 595      |
| Restore (keypad to drive) .....                        | 575      |
| Restoring default settings .....                       | 580      |
| User-set .....   | 203      |
| Verify (keypad and drive) .....                        | 576      |
| Password   |          |
| Setting .....  | 189      |
| Verification .....                                     | 189      |
| PC   |          |
| Connection procedure .....                             | 646      |
| PF   |          |
| Protective function .....                              | 484      |
| PGo  |          |
| Detection time .....                                   | 330      |
| Operation Selection after Detection .....              | 327      |
| PGoH   |          |
| Detection level .....                                  | 333      |
| Level detection (PG1) .....                            | 331      |
| Level detection (PG2) .....                            | 332      |
| Phase Order Selection .....                            | 213      |
| PID control .....                                      | 232      |
| control block diagram .....                            | 234      |
| Feedback value input .....                             | 233      |
| fine tuning .....                                      | 235      |
| Parameter .....  | 237      |
| PID feedback loss detection .....                      | 234      |
| PID Sleep .....  | 235      |
| Setpoint input .....                                   | 233      |
| PM motor parameters                                    |          |
| d-Axis inductance .....                                | 322      |
| Encoder Z pulse offset .....                           | 323      |
| Induced voltage constant 1 .....                       | 322      |
| Induced voltage constant 2 .....                       | 323      |
| Motor rated current .....                              | 321      |
| Motor rated power (kW) .....                           | 321      |
| Number of motor poles .....                            | 321      |
| q-Axis inductance .....                                | 322      |
| Stator resistance .....                                | 322      |
| PM Motor Parameters .....                              | 320      |

|   |          |
|---|----------|
| PM Motors   |          |
| Auto-Tuning.....  | 598      |
| Fine Adjustment.....                                    | 507      |
| Motor Code Selection.....                               | 321      |
| Motor Parameters.....                                   | 320      |
| Positive Temperature Coefficient (PTC) Thermistor.....  | 443      |
| Protection Functions                                    |          |
| DC bus undervoltage.....                                | 457      |
| Drive Overheating.....                                  | 483      |
| LF2.....  | 487      |
| Motor Overload.....                                     | 444      |
| oC.....   | 487      |
| oH2.....  | 483      |
| Overcurrent.....  | 487      |
| Uv1.....  | 457      |
| Protective function                                     |          |
| Desynchronization.....                                  | 491      |
| Drive Overheating.....                                  | 483      |
| GF.....   | 485      |
| Ground Fault Detection.....                             | 485      |
| HCA.....  | 489      |
| Input Phase Detection.....                              | 484      |
| Internal Drive Braking Transistor.....                  | 490      |
| LF.....   | 485      |
| Low Speed Desynchronization.....                        | 491      |
| LSo.....  | 491      |
| Motor Overheating.....                                  | 448      |
| Motor Overheating (PTC Input).....                      | 448      |
| oH.....   | 483      |
| oH3.....  | 448      |
| oH4.....  | 448      |
| oL2.....  | 486      |
| Output Current Overload.....                            | 489      |
| Output Phase Loss Detection.....                        | 485      |
| Overload.....   | 486      |
| PF.....   | 484      |
| rr.....   | 490      |
| Software Current Limit Selection.....                   | 486      |
| Pulse Train Input                                       |          |
| Terminal RP Function Selection.....                     | 436      |
| Pulse Train Input/Output                                |          |
| Parameter.....  | 435      |
| Pulse train output                                      |          |
| Terminal MP function selection.....                     | 438      |
| Wiring specifications.....                              | 642      |
| <b>R</b>  |          |
| Ready   |          |
| LED status.....   | 557      |
| Remove  |          |
| Front cover.....  | 622      |
| Terminal cover.....                                     | 622      |
| RESET key.....  | 551      |
| Restore   |          |
| Parameters (Auto Backup).....                           | 595      |
| Parameters (keypad to drive).....                       | 575      |
| Reverse Operation Selection.....                        | 210      |
| RJ-45 connector.....                                    | 551      |
| Rotational Auto-Tuning                                  |          |
| Induction Motor.....                                    | 597      |
| PM Motors.....  | 598      |
| Precautions.....  | 604      |
| rr  |          |
| Protective function.....                                | 490      |
| RUN   |          |
| LED status.....   | 557      |
| Run command   |          |
| LOCAL/REMOTE Run selection.....                         | 206      |
| Switching between LOCAL/REMOTE.....                     | 206      |
| Run Command at Power Up.....                            | 216      |
| Run Command Selection 2                                 |          |
| Switching between LOCAL/REMOTE.....                     | 215      |
| RUN indicator.....                                      | 551, 554 |
| RUN key.....  | 551      |
| <b>S</b>  |          |
| S-curve characteristics                                 |          |
| Parameter.....  | 262      |
| Sampling time setting                                   |          |
| Data log.....   | 592      |
| Serial communication terminals                          |          |
| MEMOBUS/Modbus Communications.....                      | 636      |
| Set date and time                                       |          |
| Operation.....  | 585      |
| Set time  |          |
| Operation.....  | 585      |
| Setup Wizard  |          |
| Operation.....  | 587      |
| Short Circuit Braking                                   |          |
| Parameter.....  | 217      |
| Side-by-side  |          |
| Derating.....   | 488      |
| Simple Positioning Stop.....                            | 297      |
| Slip compensation                                       |          |
| Parameter.....  | 263      |
| Software Current Limit Selection                        |          |
| Protective function.....                                | 486      |
| Software version  |          |
| Display procedure.....                                  | 594      |
| Speed Agreement   |          |
| Parameter.....  | 470      |
| Speed Detection   |          |
| Parameter.....  | 470      |
| Speed Estimation Speed Search.....                      | 222      |
| Speed limit   |          |
| Parameter.....  | 298      |
| Speed Search function                                   |          |
| Operation during momentary power loss.....              | 455      |
| Parameter.....  | 220      |
| Stall Prevention function                               |          |
| Parameter.....  | 460      |
| Stationary Auto-Tuning                                  |          |
| Induction Motor.....                                    | 597      |
| PM Motors.....  | 598      |
| Precautions.....  | 604      |
| Stationary Auto-Tuning for Line-to-Line Resistance..... | 597      |
| Precautions.....  | 605      |
| Stator resistance Auto-Tuning.....                      | 598      |
| Precautions.....  | 605      |
| Stop command  |          |
| LOCAL/REMOTE Run selection.....                         | 206      |
| STOP key.....   | 551      |
| STOP Key Function Selection.....                        | 526      |
| Stopping Method Selection.....                          | 207      |
| <b>T</b>  |          |
| Terminal block.....                                     | 636      |

|   |          |
|---|----------|
| Control circuit terminal block functions.....   | 634      |
| I/O terminals function selection switches ..... | 641      |
| Terminal function selection .....               | 643      |
| Terminal A1 .....                               | 641, 643 |
| Terminal A2 .....                               | 641, 643 |
| Terminal A3 .....                               | 641, 644 |
| Terminal AM .....                               | 641, 645 |
| Terminal FM .....                               | 641, 645 |
| Termination resistor                            |          |
| Setting switch .....                            | 645      |
| Test run  |          |
| Checklist .....                                 | 615      |
| Fine tuning .....                               | 608      |
| Procedure for no-load test run .....            | 606      |
| Procedure for test run with actual load .....   | 606      |
| Tightening torque                               |          |
| Control circuit terminals.....                  | 637      |
| Timer function                                  |          |
| Parameter .....                                 | 230      |
| Torque compensation                             |          |
| Parameter .....                                 | 298      |
| Torque Compensation                             |          |
| Parameter .....                                 | 268      |
| Torque Control                                  |          |
| Parameter .....                                 | 297      |
| Switching to/from Speed Control .....           | 300      |
| Torque limit function                           |          |
| Parameter .....                                 | 480      |
| Torque reference                                |          |
| Parameter .....                                 | 298      |
| Trend Plot                                      |          |
| Monitors .....                                  | 566      |
| Tuning .....                                    | 257      |
| <b>U</b>  |          |
| U2, U3 Initialization .....                     | 533      |
| Undertorque detection                           |          |
| Parameter .....                                 | 474      |
| Unit of measurement setting                     |          |
| Acceleration and deceleration times .....       | 260      |
| Unit selector .....                             | 525      |
| Up 2 command                                    |          |
| Parameter .....                                 | 292, 297 |
| Up command.....                                 | 375–376  |
| Parameter .....                                 | 292, 297 |
| USB port .....                                  | 551      |
| Connecting a PC .....                           | 646      |
| User Monitor Select afterPowerUp .....          | 519      |
| User Parameter Default Value .....              | 527      |
| User-Set Display Units Max Value .....          | 521      |
| User-SetDisplayUnits Dec Display .....          | 521      |
| Uv  |          |
| Speed Search Selection at Start.....            | 229      |
| Uv1   |          |
| Detection level settings .....                  | 457      |
| <b>V</b>  |          |
| V/f Pattern .....                               | 305      |
| Second Motor .....                              | 316      |
| V/f Pattern Display Unit .....                  | 520      |
| Verify  |          |
| Parameters (keypad and drive) .....             | 576      |

## W

|                                      |     |
|--------------------------------------|-----|
| Wire gauges                          |     |
| Control circuit terminals.....       | 637 |
| Wiring                               |     |
| Control circuit terminal block ..... | 638 |
| Control circuit terminals.....       | 633 |
| Main circuit terminals.....          | 631 |
| Motor.....                           | 631 |

## Z

|                          |     |
|--------------------------|-----|
| Z pulse Auto-Tuning..... | 598 |
| Zero Servo function      |     |
| Parameter .....          | 255 |



---

## Revision History

| Date of Publication | Revision Number | Section | Revised Content |
|---------------------|-----------------|---------|-----------------|
| August 2018         | -               | -       | First Edition   |

# GA800 Drive

## Programming

**YASKAWA AMERICA, INC.**

2121, Norman Drive South,  
Waukegan, IL 60085, U.S.A.  
Phone: +1-800-YASKAWA (927-  
5292) or +1-847-887-7000 Fax:  
+1-847-887-7310  
<http://www.yaskawa.com>

**DRIVE CENTER (INVERTER  
PLANT)**

2-13-1, Nishimiyaichi, Yukuhashi,  
Fukuoka, 824-8511, Japan  
Phone: +81-930-25-2548 Fax:  
+81-930-25-3431  
<http://www.yaskawa.co.jp>

**YASKAWA EUROPE GmbH**

Hauptstraße 185, 65760  
Eschborn, Germany  
Phone: +49-6196-569-300 Fax:  
+49-6196-569-398  
E-mail: [support@yaskawa.eu.com](mailto:support@yaskawa.eu.com)  
<http://www.yaskawa.eu.com>

**YASKAWA ELÉTRICO DO  
BRASIL LTDA.**

777, Avenida Piraporinha,  
Diadema, São Paulo, 09950-000,  
Brasil  
Phone: +55-11-3585-1100 Fax:  
+55-11-3585-1187  
<http://www.yaskawa.com.br>

In the event that the end user of this product is to be the military and said product is to be employed in any weapons systems or the manufacture thereof, the export will fall under the relevant regulations as stipulated in the Foreign Exchange and Foreign Trade Regulations. Therefore, be sure to follow all procedures and submit all relevant documentation according to any and all rules, regulations and laws that may apply.

Specifications are subject to change without notice for ongoing product modifications and improvements.

Original instructions.

© 2018 YASKAWA America, Inc.

YASKAWA America, Inc.



\*TOEPYAIGA8002\*

TOEPYAIGA8002  
Revision: A <0>-0  
August, 2018  
Published in U.S.A.

# YASKAWA

**YASKAWA**

GA800 Drive

**Programming**